

The application of the analytic hierarchy process when choosing layout schemes for a geokhod pumping station

R V Chernukhin, A A Dronov, M Y Blashchuk

Yurga Technological Institute, TPU, 26 Leningradskaya St, Yurga, Kemerovo Region, Russia

e-mail: chernuhin@tpu.ru

Abstract. The article describes one possibility of choosing layout schemes for geokhod systems which is the analytic hierarchy process. There is the essence of the method summarized therein. The usage of the method is considered for the analysis and the choice of layout schemes for a geokhod pumping station. Keywords: geokhod, analytic hierarchy process, pumping station, layout scheme.

1. Introduction

Underground mining processes and construction of underground facilities are demanding and expensive; there is much tension around the tasks of drifting rate increase, performance improvement of tunneling machines, operating safety as well as the reduction of mining costs. The research conducted in Russia as well as abroad around the development of new rock destruction technologies and examples of tunneling machines shows that the improvement of the performance of existing tunneling machine designs is accompanied by their increase in dimensions and weight. Besides, the shaft-sinking and tunneling machines currently used are have quite restricted digging angles.

A prospective and alternative method of mining is the geo-winchester technology. A basic element of the geo-winchester technology is geokhod which is a device that uses the subsurface for underground space drifting [1, 2].

One distinctive feature of a geokhod is an original layout scheme as well as new functional devices and elements which have not been used in the tunneling equipment before. Almost all of the geokhod systems have not only several layout scheme varieties [3, 4, 5], but also manufacturing particularities [6]. The diversity of requirements to geokhod systems and the conditions of its use make the choice of a certain layout scheme quite difficult. The decision-making method concerning the choice of a particular variety can vary from simple intuition to the engagement of highly qualified specialists.

Often, the choice problem of layout arrangements is solved by means of the table procedure. The key idea of the table procedure consists in the presentation of original data in the form of a table, where the columns are requirements to the systems, and the lines present possible variants. Layout schemes are evaluated by an expert on the basis of his/her experience, professional skills, and intuition.

The variants are evaluated according to the following scale:

“+” – the scheme completely matches the criteria;

“+–” – the scheme partially matches the criteria;

“–” – the scheme does not match the criteria.

Finally, the scheme will be chosen that gets the most positive marks.



2. Theoretical basis

In order to maintain the operation of the main systems of tunneling machines, hydraulic power units are effectively used. The system that maintains the hydraulic power unit of a geokhod is a pumping station (PS). It is the absence of scientifically based layout designs of PS and the methods of its parameters that restrains the creation of geokhods of a new technical level. This is why the research is pending concerning the development of layout arrangements and the argumentation of parameters of geokhod PS of new technical level. For the first time, the analytic hierarchy process was used in connection with geokhods when choosing the layout schemes of a pumping station which is described in details in the work [8].

In order to implement the analytic hierarchy process, we need to build a hierarchy structure for the presentation of the selection problem. For the creation of a decision-making problem structure, decomposition and synthesis are used in the AHP. At the top of the hierarchy (figure 1) there is the main goal, further, one level lower, there are the requirements to the systems, and finally, at the lowest level, there are the variants of layout schemes and design solutions of geokhod systems among which the selection and the arranging are conducted.

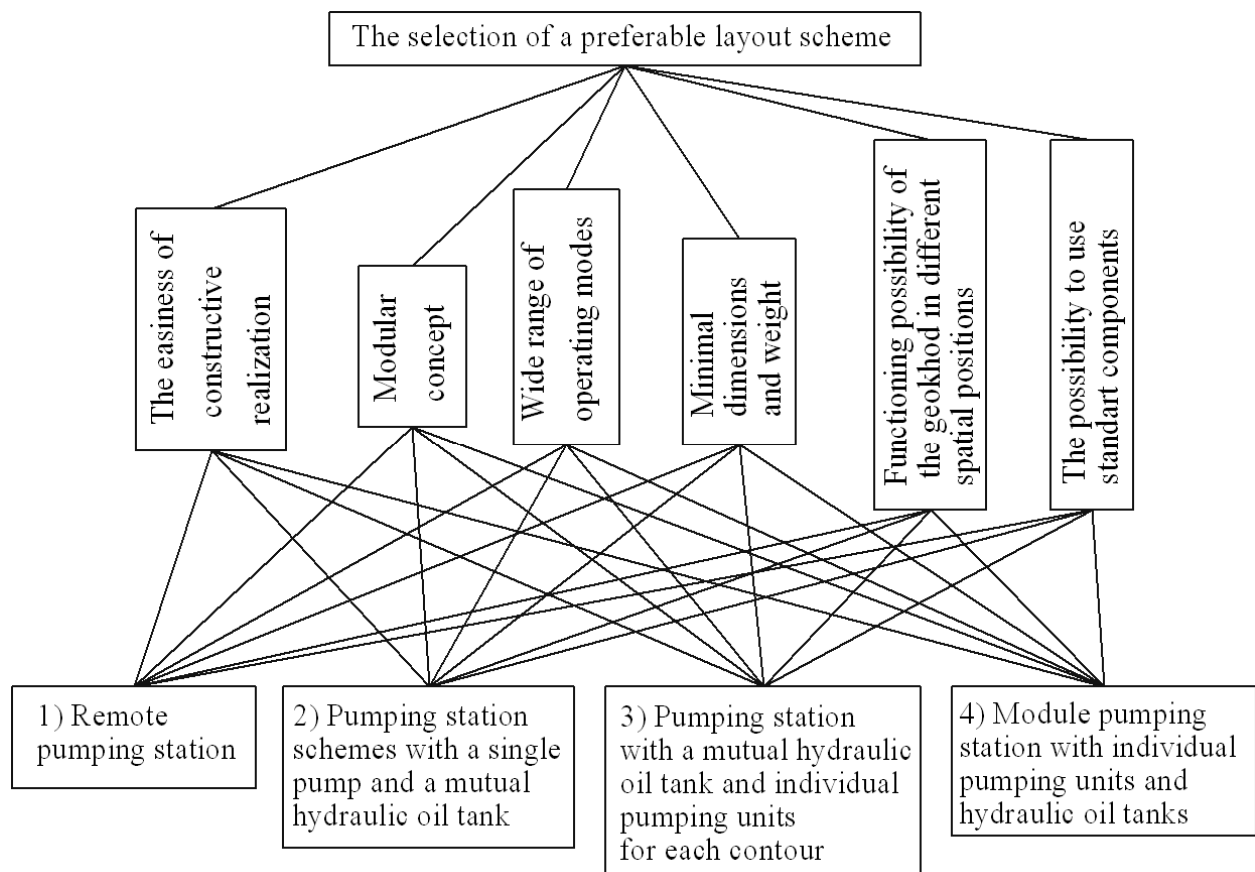

Figure 1. The hierarchy of the selection problem of appropriate variants of pumping station layout schemes

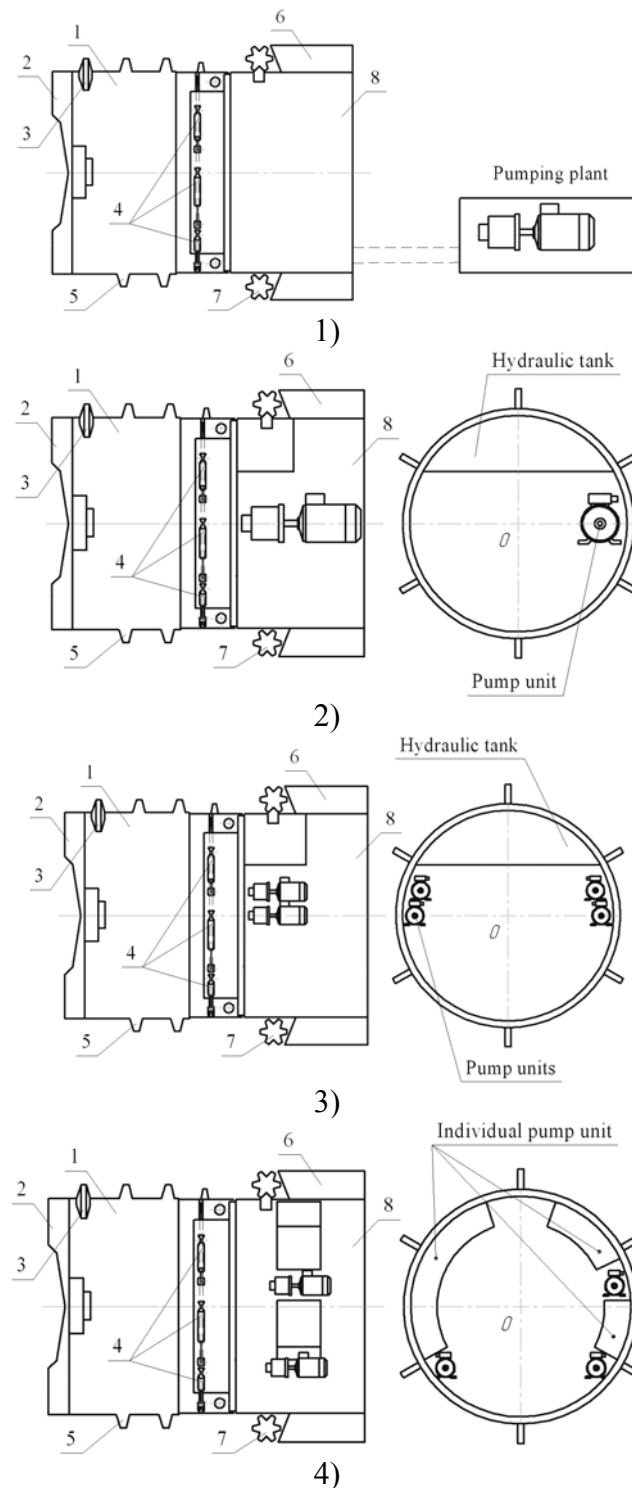

Figure 2. Layout scheme variants (alternative)

1) remote pumping station; 2) pumping station schemes with a single pump and a mutual hydraulic tank; 3) pumping station with a mutual hydraulic tank and individual pump units for each hydraulic contour; 4) module pumping station with individual pump units and hydraulic tanks

1 – head section; 2 – actuating element; 3 – actuating element of the propelling device; 4 – hydraulic cylinder of revolution; 5 – helical blade (propelling device); 6 – counterrotation element; 7 – actuating element of the counterrotation element; 8 – tail section

Out of all the diversity of layout schemes of pumping stations, we can choose the most applicable ones for certain conditions. As an example, the schemes of horizontal drilling have been picked out (figure. 2).

Within AHP, the hierarchy is the primary way to present the decision framework. Primary function of the hierarchy in AHP is the assessment of higher hierarchy levels on the basis of the cooperation of its different levels.

The next stage is a paired comparison of requirements to the pumping stations, the assessment and creation of the requirements domination matrix. Necessary calculations are performed on the basis of domination matrixes. When comparing, the requirements are evaluated according to the fundamental estimative scale. The types of marks and the principles of evaluation are described in table 1.

Table 1. Fundamental scale of analytic hierarchy process

Degree of preference	Article I.	Definition	Comments
1		Equal importance.	The two objects equally contribute to the achieving of the goal.
3		Low importance.	The experience and the thinking easily give preference to one of the two objects.
5		High or strong importance.	The experience and the thinking give strong preference to one of the two objects.
7		Very strong and obvious importance.	The preference to one of the two objects is very strong. Its dominance is almost obvious.
9		Absolute importance.	The testimonial to one of the two objects are extremely convincing.
2,4,6,8		Intermediate values between adjoining values of the scale.	Situations demanding compromise decisions.
Reciprocal variables of the above given values		In case we deduce one of the above given values when comparing object A with object B , the result of the comparison of object B with object A will be the reciprocal variable.	Given that x is more preferable than y fivefold, i. e. $x=5y$, then $y = x/5$ or $y = (1/5)x$

Table 2 shows the domination matrix for the hierarchy in figure 1. The table lists the results of the comparison of the second level objects with the main goal. There is also the preference evaluated of the given in the line requirement in comparison with the factor in the column.

In case the criterion is not dominating, an inverse value is used and entered into the table.

In order to make the results achieved by means of AHP adequate with the situation, in which the decision is made, it is necessary that required levels of data consistency are achieved in the table of paired comparison. By the consistency of paired comparison matrix the following are meant: numeric (cardinal) consistency and transitive (ordinal) consistency.

Let us consider an example of cardinal inconsistency. May layout scheme A be better than layout scheme B twofold, and layout scheme B be better than layout scheme C threefold; thus, layout scheme A is better than layout scheme C $2 \times 3 = 6$ fold. The violation of this equation within the frames of the chosen scale is considered cardinal inconsistency.

Let us consider an example of transitive inconsistency. May scheme A be more preferable than scheme B, and scheme B be more preferable than scheme C; thus, scheme A is more preferable than scheme C. The violation of the latter in equation is called transitive inconsistency.

For the purpose of determining the consistency, following indicators are identified:

- eigen value of the criteria matrix λ_{\max} (EV);
- consistency index CI.

$$CI = \frac{\lambda_{\max} - n}{n - 1},$$

where n is the order of matrix;

- consistency relation CR. The consistency relation must not exceed 0,2 (20 %). The consistency relation is determined by means of the comparison of the CI with table values of a random consistency index for mismatched matrixes.

3. Results and Discussion

Paired comparison of the requirements is given in table 2. Within the last column of the table which is called “Priority”, a relative evaluation of the requirements is depicted which is determined by means of ranging.

In the column “Priority” of table 2 a relative estimation of each criterion is depicted.

The most important advantage of the AHP is the consideration of the inequivalence of the requirements to geokhod systems, in particular, to power plants, and thus more specific results. Besides, when changing the number of requirements or exchanging one requirement with another, it is necessary only to compare new pairs and to delete the unnecessary ones from the lines and columns of the matrix of domination. Moreover, the analytic hierarchy process includes an instrument of “quality” evaluation of expert's work.

In order to decrease the complexity of mathematical calculations and to automate the application of the method, it is rational to apply the program system that realizes AHP.

In the following step, paired comparisons of layout schemes had been performed in relation to each criterion. For each criterion, a separate table had been created similar to table 2. Every layout scheme was given an esteem according to the fundamental scale of AHP.

Table 2. Paired comparisons of the criteria of the geokhod pumping stations for horizontal drilling

Criterion	The easiness of constructive realization	Modular concept	Wide range of operating modes	Minimal dimensions and weight	Functioning possibility in different spatial positions	Application of standard components	Priority
The easiness of constructive realization	1	1/9	1/5	1/5	9	1	0.0589
Modular concept	9	1	1/9	1/3	9	5	0.1581
Wide range of operating modes	5	9	1	3	9	9	0.4745
Minimal dimensions and weight	5	3	1/3	1	9	3	0.2281
Functioning possibility of the geokhod in different spatial positions	1/9	1/9	1/9	1/9	1	1/9	0.0161
Application of standard components	1	1/5	1/9	1/3	9	1	0.0641
Eigen value of the comparison matrix 7.3229 Consistency index 0.1949 Consistency relation 0.1572							

As a result of the application of AHP for the selection of layout schemes of a geokhod pumping station, it was deduced that the preference should be given to geokhods for horizontal drilling with remote pumping stations which provide power fluid supply in different spatial positions, as well as with integrated modular pumping stations with separate or mutual hydraulic tanks (figure 3).

Variants 3) and 4) cede to other layout arrangements because they do not guarantee the dimensions of the interior space. Besides, the application of one pump unit for the simultaneous feeding of hydraulic cylinders and hydraulic motors is restricted.

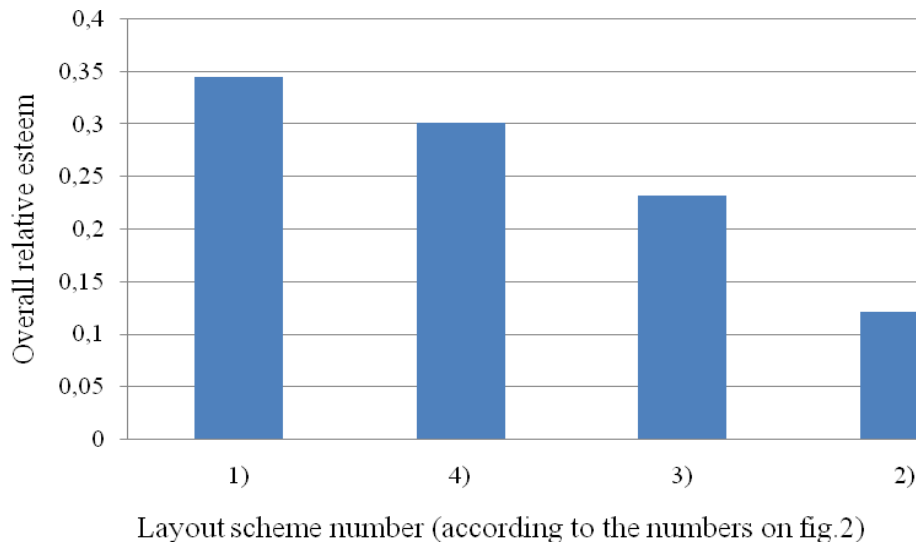

Figure 3. Conclusive result of the AHP based on layout arrangements.

Thus, the application of the AHP for the selection of an optimal decision about layout schemes of geokhod pumping stations includes following steps:

1. The construction of the corresponding hierarchy of a decision-making task.
2. Paired comparison of all requirements to the pumping stations.
3. The elimination of the inconsistency of the domination matrixes of requirements (if necessary).
4. Paired comparison of all layout schemes according to all requirements.
5. The elimination of the inconsistency of domination matrixes of layouts according to the requirements (if necessary).
6. The presentation of a diagram with the variants of layout schemes and the selection of an optimal decision.

It should be noted that, when estimating the preference of one or another layout arrangement, exploitation conditions of the geokhod are an important factor. This means that final results of the AHP about the layout schemes under different conditions (for instance, the usage of the geokhod for slope working, or the application of a small diameter geokhod) can vary.

References

- [1] Efremenkov, A.B., 2011. Forming the subterranean space by means of a new tool (geokhod), in: 7th International Forum on Strategic Technology (IFOST – 2012): Proceedings: In 2 Vol. IEEE, p. 348-350.
- [2] Aksenov, V.V., Khoreshok, A.A., Beglyakov, V.Y. Justification of Creation of an External Propulsor for Multipurpose Shield-Type Heading Machine – GEOKHOD. Applied Mechanics and Materials (2013) 379, p. 20-23.
- [3] Timofeev, V.Y., Aksenov, V.V., Galajamova, I.J. Determination of parameters of roller of wave transmission with intermediate rolling bodies with hollow shaft for geokhod. Applied Mechanics and Materials (2014) 682, p. 246-250.
- [4] Aksenov V.V., Blashchuk M. Y., Dubrovsky M. V. Estimation of torque variation of geohod transmission with hydraulic drive. Applied Mechanics and Materials. (2013) 379. p. 11-15

- [5] Efremenkov, A.B., Aksenov, V.V., Blashchuk, M.Y.. Force parameters of geohod transmission with hydraulic drive in various movement phases, in: 7th International Forum on Strategic Technology (IFOST - 2012): Proceedings: In 2 Vol. (2012) IEEE, p. 159-163.
- [6] Aksenov, V.V., Walter, A.V., Beglyakov, V.Y., 2014. Ensuring the geometric accuracy of shell during assembly of Geohod sections. *Obrabotka metallov (Metal working and material science)* 4, p.19-28. (2014)
- [7] What is the Analytic Hierarchy Process? *Mathematical Models for Decision Support NATO ASI Series Volume 48*, (1988), p. 109-121
- [8] Blashchuk, M.Y., Kazantsev, A.A., Chernukhin, R.V. Capacity Calculation of Hydraulic Motors in Geokhod Systems for Justification of Energy-Power Block Parameters. *Applied Mechanics and Materials* (2014) 682, p. 418-425.