

Ultrasonic plastic deformation of steels

K Zaitsev¹, V Klimenov^{2,3}, M Loshchilova¹, C Polovnikov¹

¹ Yurga Institute of Technology, TPU affiliate, 26, Leningradskaya Str., 652050, Yurga, Russia

² National Research Tomsk Polytechnic University, 30, Lenin Ave., 634050, Tomsk, Russia

³ Tomsk State University of Architecture and Building, 2, Solyanaya Sq., 634003, Tomsk, Russia

E-mail: zaitsev81@rambler.ru

Abstract. In the work we demonstrate the possibility of forming thin surface and near-surface layers with submicrocrystalline structure under ultrasonic plastic deformation of machined steels. Formation of fine gradient textures up to nanocrystalline allows significant changing physical and mechanical properties of machined steels. Ensures improvement of microstructure, produces internal compressive strains which improves the cyclic strength of machine parts.

1. Introduction

In recent times attention of Russian and foreign scientists is attracted to the problem of structural materials modification due to external high-energy impacts [1]. A characteristic feature of such technologies is insignificant time of impact upon the processed surface and high energy density (dozens and hundreds of J/cm²) of input energy. As a result the processed surface layer obtains modified and gradient structure.

One of the methods of high energy impact upon metal surface is ultrasonic metal deformation (ultrasonic treatment) when the surface of the part after machining is impacted by a tool (a ball) oscillating with ultrasonic frequency [1-3, 7-11].

The oscillating system of the ultrasonic device for strengthening metallic parts is additionally loaded with static force determining the hold-down pressure. For the purposes of the whole surface treatment motion is transmitted to the part or to the tool. The parts to undergo ultrasonic treatment can be of varying forms: round, flat and profiled [4-6, 10, 11].

For the practical application of the ultrasonic treatment method we need ultrasonic equipment – special ultrasonic unit and ultrasonic low power generator (0.2-0.4 kW), tool. Treatment of outside and inside surfaces can be completed on metal-working (turning, milling) machines of normal accuracy.

The basic parameters of ultrasonic strengthening are: value of static pressure of the tool upon the machined part, speed of the main oscillating motion, longitudinal and traverse feed, number of passes, size and form of the tool. Oscillating motion of the tool produces internal stresses in the surface layer of the machined part [2, 3, 9, 10].

Assisting motion (feed motion) and the number of passes characterize the number of impacts per unit of machined area in a unit of time. The size and the form of the ultrasonic tool influence the impact force and, thus, the pressure the machined part surface undergoes [11].



Ultrasonic treatment is characterized by a number of peculiarities which distinguish this method from other types of surface deformation. The first characteristic is shock loading which periodically repeats and involves comparatively small area. The second peculiarity is microhardness increase by 1.5 and more times and ensuring its favorable distribution over the depth of the cold-worked layer, reducing the roughness of the surface and producing residual compressing stress. The third peculiarity of ultrasonic treatment is producing quickly alternating compressive and shear deformations.

The physical and mechanical condition of the surface layer (roughness, microhardness, internal residual stresses) is strongly influenced by specific for this process elements: the value of the static pressure of ball hold-down towards the part, shift amplitude of the part, oscillation frequency and other. The static force ensures contact between the ball and the machined part. Shift amplitude and static pressure produce the main influence upon the surface roughness, the degree and the depth of cold-working, value of residual stresses in the surface layer of metal and its other physical and mechanical properties. Choice of shift amplitude and static hold-down pressure of the ball determine the productivity of machining, feed and rotation velocity of the part, number of passes. The value of the static force must be the larger the less ductile part material is, the higher original roughness is, the larger are diameters of the strengthened part and ball, the larger are feed and rotation speed.

In the given work we study the influence of ultrasonic plastic deformation upon structure and properties of surface layers of low-carbon, medium-carbon and high-carbon steels of ferrite, ferrite-pearlite and pearlite classes. The possibility of formation submicrocrystalline up to nanocrystalline structure of surface layer of machined metals [12-14], improving cyclical strength, wear resistance as well as reliability and life time of various machine parts.

We selected the original roughness of the surface as the technological factor upon which the efficiency of submicrocrystalline and nanocrystalline structure formation may depend when applying ultrasonic plastic deformation. As the planishing effect is localized in the thin surface layer the original roughness of the surface will have significant influence upon the degree of deformation.

2. Materials and methods

The ultrasonic impact upon the surface of metal workpieces was caused with the use of technological complex [15]. The complex is of small size, it is characterized with reliability and stability of work. Machining was completed with the power output of 200-300 W and with indenter amplitude of oscillation $\xi_{\text{ИИД}}=20 \mu\text{m}$. The diagram of indenter impact upon the surface of the turning part is presented in Figure 1. The static force F_N , ensuring the physical contact between the indenter and the machined surface, and the shift amplitude (under the given frequency of oscillations $f=2 \cdot 10^4 \text{ c}^{-1}$) determine the value of stresses, the number of singular acts of deformation and their speed.

Machining of metal samples was completed in the following way: preliminary machining of the workpiece on the turning machine [16, 17] with further ultrasonic plastic deformation. Sample 2 (Figure 2, position 1) was mounted into three-jaw universal 1 of the turning machine and tightened with back center 3. We completed turning of journals of the samples under the following conditions: longitudinal saddle feed – from 0.04 to 0.28 mm/rev; cutting depth – from 0.5 to 1 mm; the angle in the plane of the turning tool φ from 40° to 85° . Machining formed the surface with various microrelief and roughness R_z 10-20 μm and keystone form rims of roughness profile with base width of 25-35 μm and angle of lateral side inclination of 5° - 10° (Figure 3 a).

Then, instead of cutter 4 we insert ultrasonic impact driver 5 into the toolholder (Figure 2, position 2). The surface of workpiece 2 is machined with hard-alloy indenter oscillating at ultrasonic frequency. In the zone of local contact between the indenter and the machined surface the deformation region appears which travels with the indenter. That kind of machining results in formation of a surface with peak to trough height R_z 3.5-5.5 μm (Figure 3 b). High grade finish is achieved due to localization of finishing action of indenter in the thin surface layer, namely on the peaks remaining after preliminary turning machining.

Further in the work we studied the microstructure of the samples in the area of formation gradient structures with the application of optical and transmission electron microscopy. Combined application

of the given methods of research allowed completing the most comprehensive analysis of structure which is rather difficult to do with application of only one of these methods. The detailed study was completed in work [18].

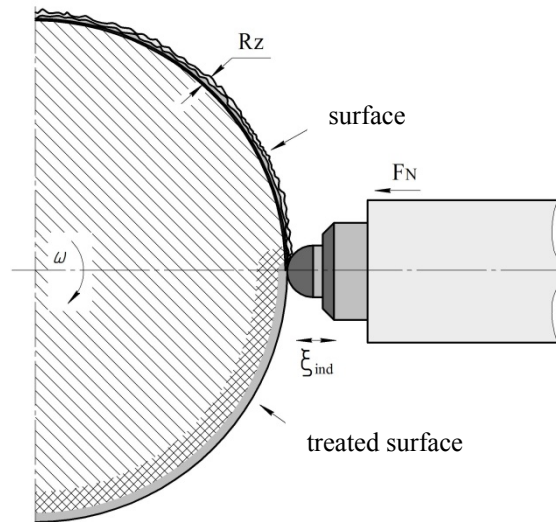

Figure 1. Diagram of ultrasonic finishing: ξ_{ind} – amplitude of indenter oscillations; F_N – static force; ω – angular rate.

The structure study of metallographic sections prepared according to the standard techniques [19, 20] was carried out with microscope “MIM-10”. To reveal the grain structure we completed chemical etching according to [21, 22]. Thin steel foils were studied with device “EM-125” under accelerating voltage 125kV. The operating magnification in the microscop column was 8000 – 80000 power.

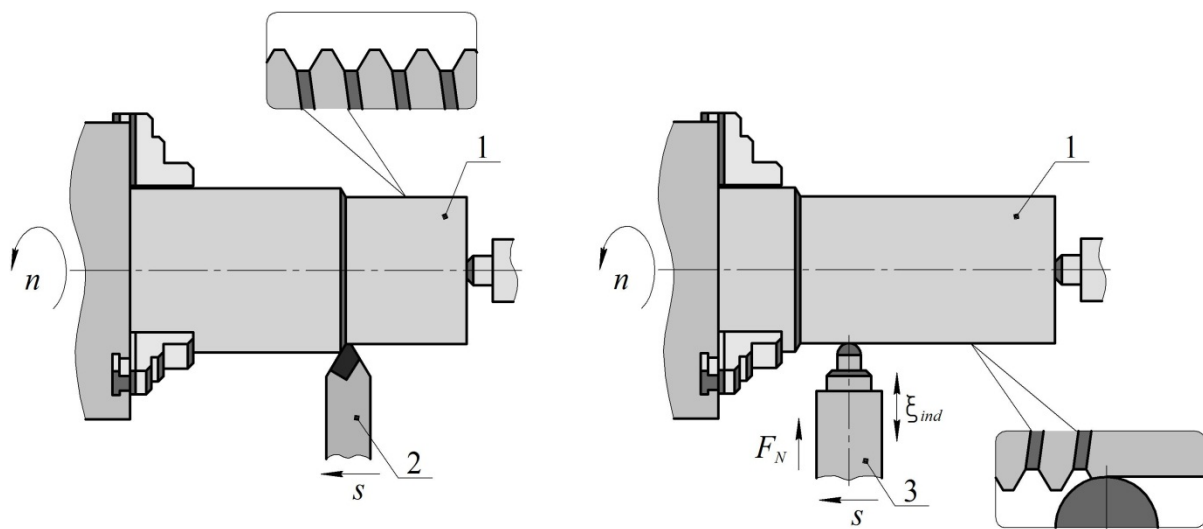

Figure 2. The diagram of finishing with ultrasonic tool: 1 – workpiece; 2 – cutter; 3 – ultrasonic tool

To measure surface roughness and to study surface morphology we applied optical 3D-profilometer “Micro mesure 3D station”. Measuring was completed by non-contact method with a scanning laser beam. Line-by-line scanning allows obtaining high-accuracy 3D-image of the measured region of the surface.

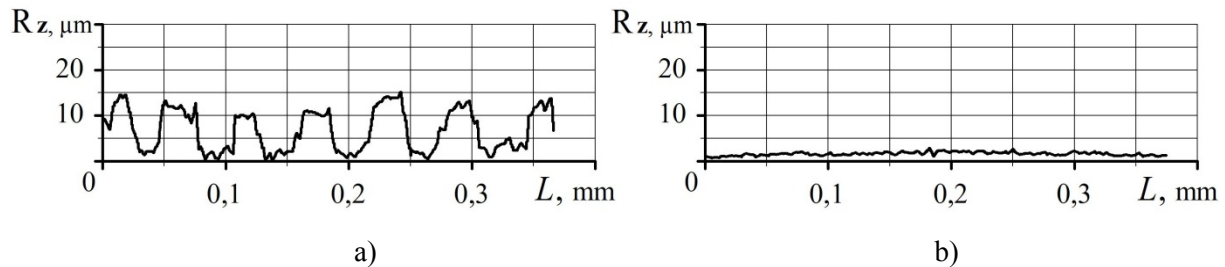

Figure 3. Surface profilogram after: a – preliminary machining; b – after ultrasonic finishing

The results were processed with the application of software “Mountains Map” («SARL Digital Surf», France). Surface roughness was estimated according to Rz and Ra (GOST 2789-73). Microhardness estimation according to GOST 9450-76 was completed with application of “Nano Hardness Tester” and “PMT-3” with indenter load of 0.49 ± 0.98 N. Microhardness was measured according to the method of reconstructed image, by pressing a diamond quadrihedral pyramid with the angle of 136 between opposite planes.

3. Results and discussion

As a result of ultrasonic plastic deformation of metal samples we observe cardinal changes in the structure of surface and subsurface layers and significant increase of microhardness. In the metallographic image of the structure (Figure 4 a), in the surface layer with the thickness of 2-3 μm we observe a nonerodible layer, and at the depth of 3-12 μm – non-equiaxial grains protruded in the direction of machining. Then there is smooth transition to the original structure of steel.

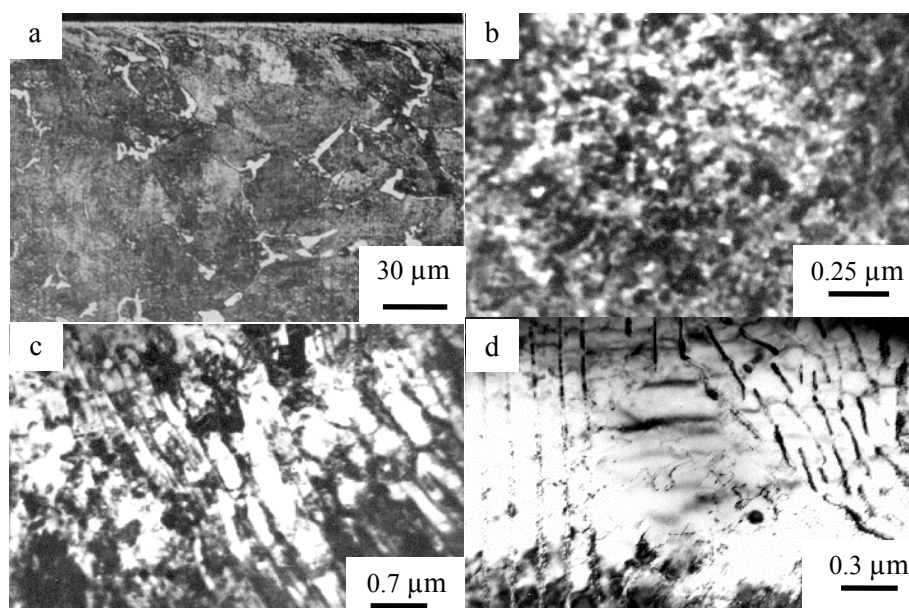

Figure 4. Metallographic (a) and electron-microscopic images of steel 60 after ultrasonic finishing at the depth of 3 μm (b), 10 μm (c), 450 μm (d)

For more detailed study of the microstructure of samples (for steel 60) after the ultrasonic plastic deformation electron-microscopic investigations were completed. Their results are presented in Figure 4. In the original state (in the core of the sample) steel 60 mainly has pearlite structure. Pearlite is lamellar, ferrite grains are situated between the pearlite colonies and gravitate toward the original austenite grain junction line. Grains of free microcrystalline ferrite can also be found in pearlite colonies (Figure 4 d).

After turning machining and further ultrasonic plastic deformation, in the 2-3 μm thick surface layer of the sample we observe nanocrystalline structure consisting of a mixture of α -phase crystalline particles chaotically situated cementite particles (Figure 4 b). Regions of free ferrite characteristic of the original state structure are practically absent. At the depth of 3-10 μm the grain, although deformed, structure of the original material is retained and substructural transformations in lamellar pearlite are observed, for example, fragmentation of ferrite lamels and cementite lamels (Fig. 4 d). The structure of free ferrite regions becomes subgrain. It should be noted that in the structure of ferrite subgrains, in contrast to original grains, carbide phase is found indicating higher diffusion mobility of carbon atoms under ultrasonic plastic deformation and their mass transfer into the regions of large enough ferrite grains.

The results of study of microhardness values distribution in the sample section are presented in Figure 5. For all studied steels maximal microhardness values after the ultrasonic plastic deformation are found on the surface. The microhardness value uniformly decreases depthwise up to the microhardness level of original alloy material. Uniform decrease of microhardness (the studied depth was up to 400 μm) is determined by the changes of macro-, micro- and submicrostructure of steel as well as by behavior of residual variation of compressive stress under ultrasonic plastic deformation. Maximum absolute microhardness values on the surface of the studied samples and the depth of the hardened layer depend upon carbon concentration in steel and increase with the growth of carbon content.

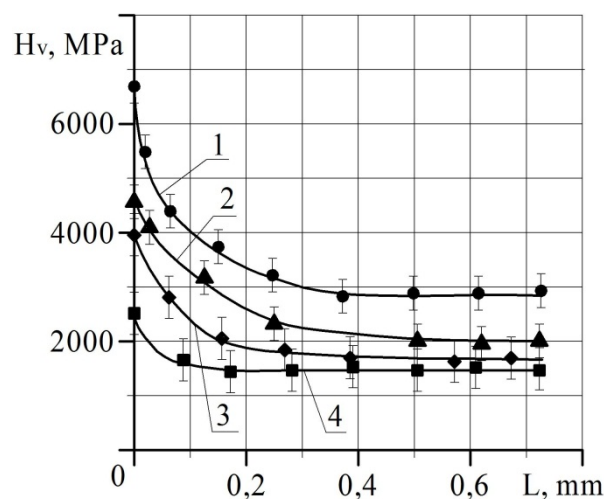

Figure 5. Microhardness depthwise distribution in steel samples after ultrasonic finishing:
1 – steel 60; 2 – steel 45; 3 – steel 20; 4 – steel 3

Figure 6 presents dependence of surface layer microhardness after ultrasonic plastic deformation upon the value of original roughness after preliminary turning. Reduction of original roughness contributes to reduction of microhardness values up to the values which are characteristic of original metal. It indicates the low degree of deformation of roughness peaks obtained after preliminary turning machining. Growth of original roughness up to certain level (R_z 10-25 μm) contributes to increase of microhardness values in the surface layers after the ultrasonic plastic deformation due to

the high degree of roughness peaks deformation. At the same time further increase of roughness leads to decrease in surface microhardness due to intensive accumulation of macrodefects of the surface layer in the form of incompletely deformed roughness peaks after the ultrasonic plastic deformation. With the values of surface roughness less than Rz 4-8 μm deformation is less intensive due to small size of roughness peaks.

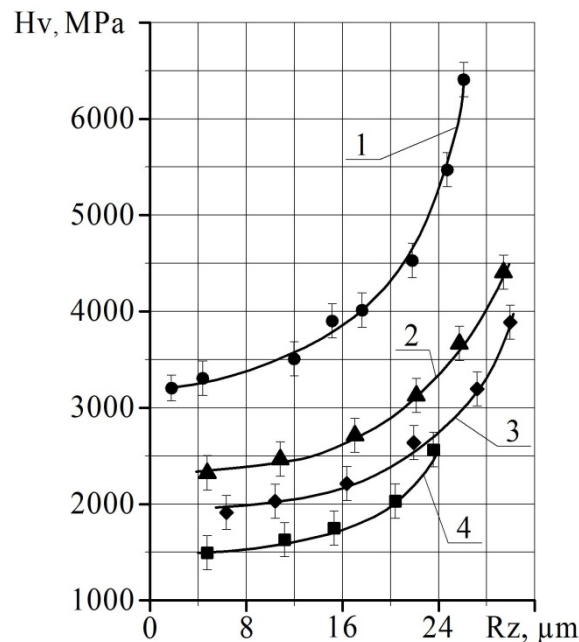

Figure 6. Dependence of surface layer microhardness after ultrasonic treatment upon the original roughness value obtained after preliminary turning:
1 – steel 60; 2 – steel 45; 3 – steel 20; 4 – steel 3

Forming on the surface a plastically deformed modified layer with a large concentration of dislocations and a diffused interface with the basic material distinctly slows down formation of dangerous stress concentrators and fatigue cracks nucleation blocking development of fatigue processes on the surface. At the same time abrasive-adhesive wear is also reduced due to surface hardness increase. On the finished surface a surface layer with nanocrystalline structure is formed and the depth of the modified layer with elastically plastic stress fields and net dislocation substructure increases up to 400 μm for steel 60[23, 24].

Conclusion

With consideration to the fact that the problem of producing nanocrystalline structures with corresponding improvement of physical and mechanical properties on massive parts is not yet solved, the obtained results are rather important. They give a possibility of producing fine nanocrystalline structure on the parts of any sizes and any geometry (leading spindles, stamping tools, piston plungers, etc.) which significantly increases hardness, wear resistance, cyclic strength and operational life of various parts and machine units.

References

- [1] Odintsov L G Strengthening and finishing of machine parts by surface plastic deformation: Reference book – M : Mashinostroyeniye 1987 – 328 p il
- [2] Abramov O V Khorbenko I G Shveгла Sh Ultrasonic finishing of materials / Under the editorship of O V Abramov – M : Mashinostroyeniye 1984 – 280 p il

- [3] Severdenko V P Klubovich V V Stepanenko A V Metal forming with application of ultrasound minsk: Nauka I tehnika 1973 p 288
- [4] Abramov O V Gurevich L B Influence of ultrasound upon the structure and properties of pure metals // FHOM – 1972 – №3 – P 18-20
- [5] Abramov O A Dobatkin V I Kazantsev V F and others Influence of high power ultrasound upon the inter-phase surface of metals M : Nauka 1986 – 227 p
- [6] Abramov O V Khorbenko I G Shveгла Sh Ultrasonic finishing of materials / Under the editorship of O V Abramov – M : Mashinostroyeniye 1984 – 280 p il
- [7] Klimenov V A Panin V Ye Bezbodov V P and others Substructure and phase transformations under ultrasonic machining of martensitic steel // FHOM – 1993 – № 6 – P 77-83
- [8] Klimenov V A Ivanov Yu F Perevalova O B and others Structure phase composition and mechanisms of strengthening austenite steel treated by ultrasound // FHOM -2001 – P 90-97
- [9] Klimenov V A Nekhoroshkov O N Uvarkin P V Kovalevskaya Zh G Ivanov Yu F Structure phase composition and properties of steel 60 after ultrasonic finishing // Physical mesomechanics – 2006 – V 9 – Special issue – P 173-176
- [10] Markov A I Ultrasonic treatment of materials – M : Mashinostroyeniye 1980 – 237 p il
- [11] Markov A I Application of ultrasound for machining and surface strengthening of hard-to-machine materials // Application of ultrasound in production Under the editorship of Makarov A I M : Mashinostroyeniye 1975 – P 157-180
- [12] Lotkov A I Baturin A A Grishkov V N Kuznetsov P V Klimenov V A Panin V Ye Defects of structure and mesorelief of the surface of titanium nickelide after intense plastic deformation according to ultrasonic method Physical mesomechanics – 2005 – V 8 – Special issue – P 109-112
- [13] Klimenov V A Nekhoroshkov O N Uvarkin P V Ivanov Yu F Ultrasonic finishing as the method of producing nanocrystalline structures // Physicochemistry of ultradisperse (nano-) systems Works of VI All-Russian (international) conference M : MEPhI – 2002 – P 168
- [14] Klimenov V A Nekhoroshkov O N Uvarkin P V Ivanov Yu F Formation of nanocrystalline structure on the surface of railway power head wheelset tyres with application of ultrasonic machining // Experience of innovation enterprises in commercialization of nanotechnologies Works of All-Russian (international) conference “ Physicochemistry of ultradisperse (nano-) systems” August 19-23 2002 TPU publishers – 2002 – P 57-61
- [15] Ultrasonic technological package UZTK-02 Operations manual
- [16] V A Petrova A A Bakanov and A V Walter “Crack Resistance of Weld Seals Hardening Methods and Composite Tools Quality ” Applied Mechanics and Materials vol 682 pp 431–437 2014
- [17] A A Lasukov P A Chazov A V Barsuk Investigation on the Elemental Chip Formation Process in Hard-to-Machine Material Cutting Applied Mechanics and Materials Vol 682 (2014) pp 504-509
- [18] Alfeyorova E A Lychagin D V Characterization of deformation pattern structure elements generated in uniaxial compression of nickel single crystals // Applied Mechanics and Materials – 2013 – v 379 – pp 66-70
- [19] Tushinsky L I Plokhov A P Study of structure and mechanical properties of coating – Novosibirsk: Nauka 1986 – 200p
- [20] Tushinsky L I Plokhov A P Tokarev A O Sindeyev V I Methods of material study: Structure properties and processes of applying inorganic coatings – M : Mir 2004 – 384 p : il
- [21] Kovalenko V S Metallographic reactivities Reference book – M : Metallurgiya 1981 – 120 p
- [22] Baranova L V Demina E L Metallographic etching of metals and alloys – M : Metallurgiya 1983 – 256p
- [23] Klimenov V A Zaitsev K V Borozna V Y Formation of metal –polymer composite on titanium alloy surfaces // Applied Mechanics and Materials 2014 – v 682 pp 453-458
- [24] Kovalevskaya Z G Klimenov V A Zaitsev K V Interfacial adhesion between thermal spray coating and substrate achieved by ultrasonic finishing // Applied Mechanics and Materials – 2014 v 682 pp 459-463