

Exploration and local forecast of gold-ore deposits based on typomorphic properties of pyrite

A Ya Pshenichkin^{1,3}, Yu S Ananyev¹, A I Bushmano¹ and R N Abramova²

¹ Department of Mineral Exploration, Institute of Natural Resources, National Research Tomsk Polytechnic University, 30 Lenin Ave., Tomsk, 634050, Russia

² Department of Foreign Languages, Institute of Natural Resources, National Research Tomsk Polytechnic University, 30 Lenin Ave., Tomsk, 634050, Russia

E-mail: ³ paya@tpu.ru

Abstract. The article describes the data in exploration and local forecast of gold-ore deposits based on typomorphic pyrite properties. The pyrite properties: crystal shape, impurity-elements and thermal EMF change in relation to the deposit formation conditions are consistent with the mineralogical and geochemical zoning of ore bodies and deposits. In this case, it is possible to evaluate the ore zone erosion, prospectivity and productivity of the ore bodies at depth and flanks. Mineralogical sampling on pyrite and gold should be conducted on the basis of other methods during exploration and mining.

1. Introduction

Nowadays, effective prospecting-evaluation survey is impossible without the development and implementation of mineralogical and geochemical methods in forecasting, exploration and evaluation of mineral deposits. The conducted integrated study of pyrites in genetically different gold-ore deposits established the fact that pyrite is one of the most abundant and informative mineral in a deposit where the typomorphic properties change in relation to deposit formation conditions [4, 5, 8]. The information encoded in a mineral furthers the deciphering of the pyrite crystallization conditions and the deposit genesis, in general [1, 2, 6, 7].

2. Pyrite crystallomorphology

Pyrite crystal shape (figure 1) is one of the contrastive and sharp typomorphic features of pyrites in different mineragenic gold-ore deposits [3, 4, 7, 8]. The unique morphological features of pyrite crystals are specific for every deposit individually.

The pyrites in gold-quartz deposits predominately have a cubic crystal habit. Although simple crystals – {100}, {210} and {111} are rarely found in hyperthermal quartz-gold ore associations, they are more often found in combined forms (for example, Maslov, Podlunntinovsk and Konstantinovsk deposits). In medium-temperature gold-sulphide associations the pyrite crystals are hexanedron (in Balakhchinsk, Kuzhnetsk, Znamenitsk and Medvezhe deposits), while in medium-low temperature quartz-gold-polymetallic sulphide associations are hexanedron and / or pentagonal-dodecahedral habit (in Lisogorsk and Saralinsk deposits). Pyrites in gold-skarn deposits have octahedral crystal habit (in



Kalistrovsk and Tardansk deposits). According to the strike and down-dip direction of ore-bodies (trending to pinch-out), pyrite morphology changes regularly, revealing the alteration of pyrite crystal habit from pentagonal-dodecahedral to cubic (Saralinsk ore field, figure 2) or from cubic to cubic pentagonal-dodecahedral (Balakhchinsk, Lisogorsk, Medvezhe and Konstantinovsk deposits). The most significant morphological variations and the least combinative stability of pyrite crystals have been observed in ore chimneys, predominately revealing a pentagonal-dodecahedral habit (figure 3, table 1).

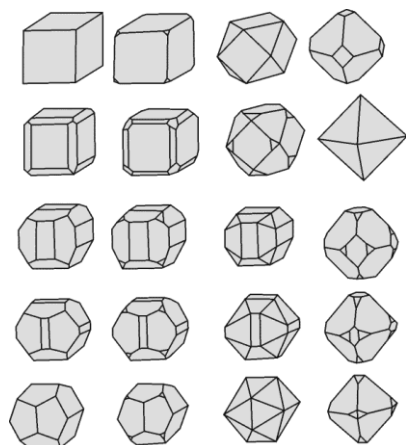

Figure 1. Basic morphological types of pyrite crystals in pyrite gold-ore deposits.

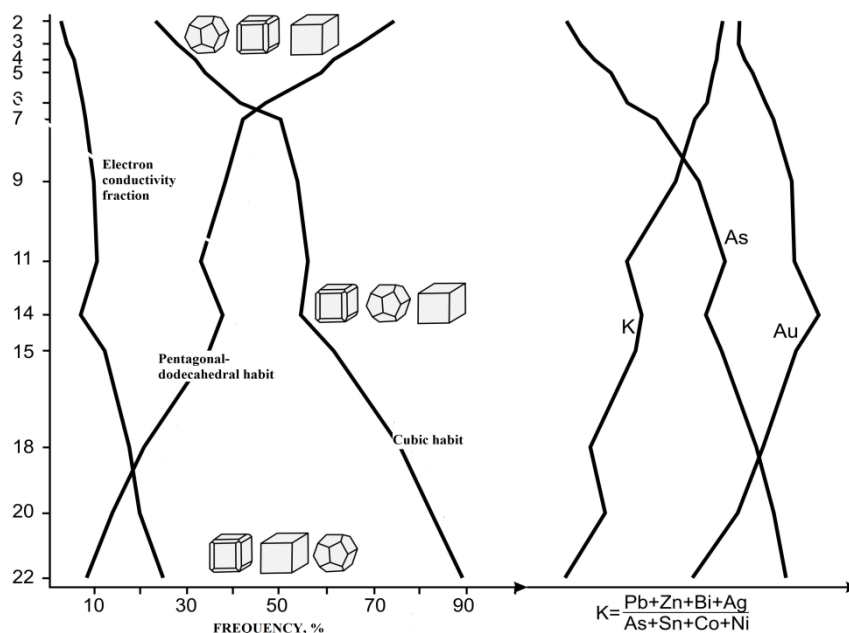

Figure 2. Content alteration of element impurities, crystallomorphology and thermal EMF in pyrites within gold veins of Kaskad- Saralinsk gold-ore field.

3. Research results and discussion

The pyrites in Kaskad and Andreevsk gold deposits (Saralinsk gold-ore field) were investigated in detail (more than 0.9km. down-dip and about 3km. along the strike). The spatial zoning of crystal morphological alteration was defined, which, in its turn, reflected the regular pyrite crystal habit changes from pentagonal-dodecahedral to cubic in the directions to strike, down-dip and across the strike (figure 2). It was determined that pyrites with pentagonal-dodecahedral habit is predominate in

significantly rich ore chimneys (figure 3) in crystal types and morphologically diverse; whereas, in pinching-out areas, along the strike and down-dip direction, the combination of pyrite crystals decreases to a minimum. Based on the obtained information on the pyrite crystallographical regularities, the ore zone erosion and its prospectivity more than 100 ore veins were evaluated and defined. The ore zone erosion in the ore field increases westward and south-westward (figure 4).

Chemical composition is another specific typomorphic feature of pyrites in gold-ore deposits (table 1). Comparable to other genetically different pyrites, pyrites in gold-ore deposits exhibit significant static parameter scattering of impurity-element distribution (\bar{X} , S^2 , V). This is particularly relevant for element complexes in gold-ore deposits, where significant concentrations of Au, Ag, Cu, Pb and Zn were accumulating constantly in pyrites of gold-ore deposits.

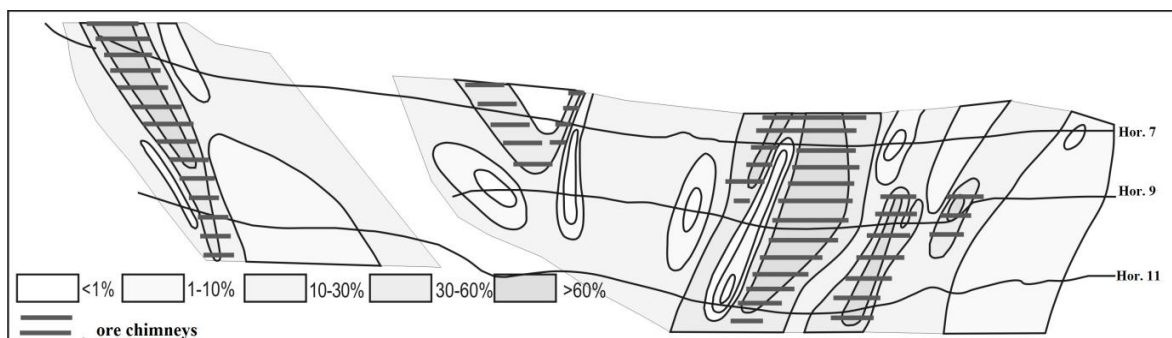

Figure 3. Distribution of pentagonal-dodecahedral pyrite crystals (%) in bedded veins (Kaskad-Saralinsk ore field).

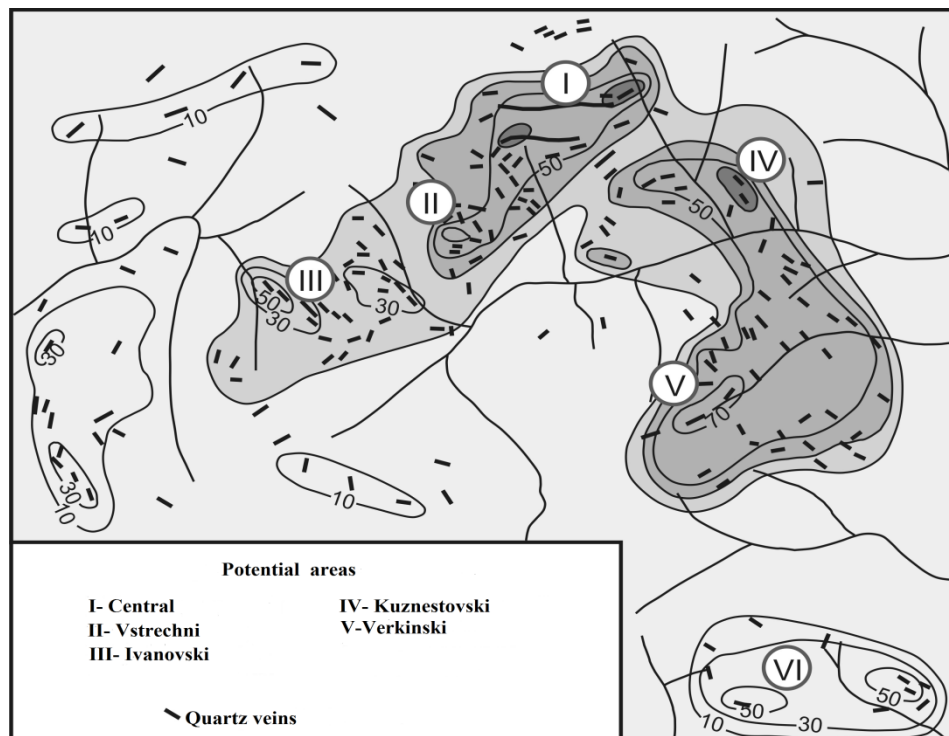

Figure 4. Distribution of pentagonal-dodecahedral pyrite crystals within Saralinsk ore field.

Gold-quartz formation exhibits 1.5-2-fold pyrite enrichment by Au, Ag, As, Pb, Bi, Sn, Cd, and Ba comparable to the pyrites in gold -skarn deposits. There is a higher concentration accumulation of Mo, Zn and rarely, Ti, Co in the latter. However, in this case, pyrites in high-temperature gold-quartz associations are enriched by Mo, Ti, Cr, Co, Ni, V, As and Bi (for example, in Kommunarovsk and Tardansk deposits); pyrites in medium-temperature gold-quartz-sulphide associations are enriched by Au, Cu, Pb and Zn (in Balakhchinsk and Medvezhe deposits); while pyrites in medium-low-temperature gold-quartz- polymetallic sulphide associations are enriched by Hg, Ba, Ag, Sb, and As (in Lisogorsk and Saralinsk deposits).

Pyrites in gold-ore deposits are rarely enriched by gold in comparison to other genetically different pyrite deposits [2, 4, 5]. However, a rather high gold concentration is observed in pyrites from stringer-porphyry and porphyry ores in black shale formations, where these concentrations are up to 50gr/t and more (figure 5). The gold concentration level in the pyrites of above-mentioned deposits increases from diagenetic pyrite to metamorphogenic and ore-forming pyrites. The latter is 100-1000 times (and even more) enriched by gold comparable to diagenetic pyrites.

The zonal (wavelike, the amplitude of which is 200-240 m) distribution of impurity elements in pyrites at deep-seated ore bodies was determined. It was observed that the Ba, Hg, Ag and Sb concentrations (sometimes As) are predominant in the pyrites in the upper part of ore bodies and supraore haloes; pyrites in the mid part of ore bodies are dramatically enriched by Au, Cu, Pb, Zn, while pyrites in the bottom of ore bodies accumulate Ni, Co, Ti, and Cr (sometimes As, Cu) and the remaining elements are sharply depleted [5, 6, 10]. In this case, the chemical composition of pyrite could be used to evaluate the ore zone erosion of orebodies (figures 2, 5).

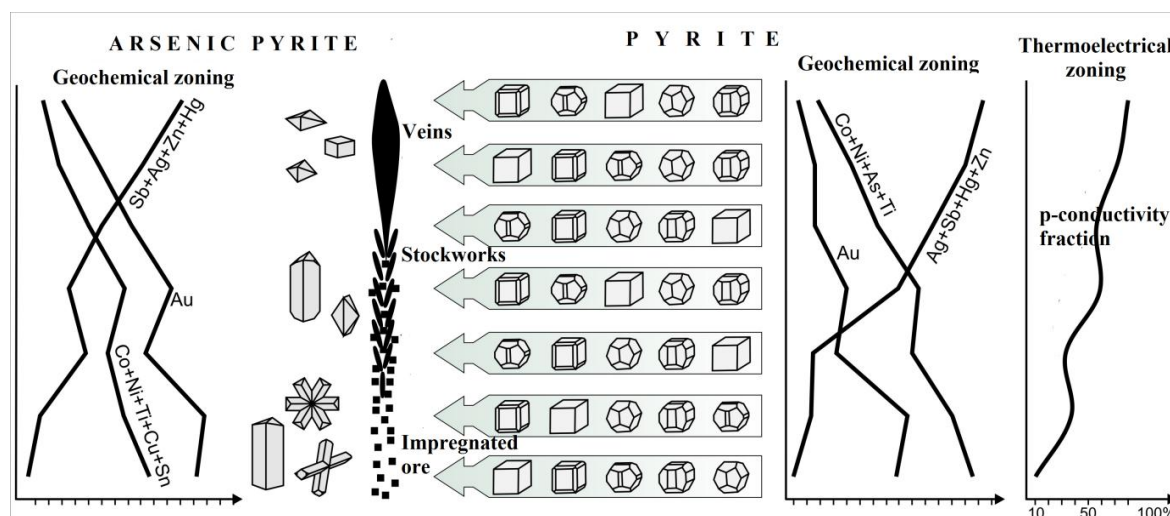

Figure 5. Generic model of pyrite zoning in the Western Kalba gold-ore deposits.

The most informative physical property for pyrites [4, 9] is thermal EMF (figure 5, table 1). Pyrites in orebodies and near-ore mesomatites of gold-ore deposits, Altai-Sayan folding area, exhibit thermal EMF parameters, governed by the characteristic features of pyrite formation and having mixed conductivity, predominately, electronic (Spasskoe, Kaliostovskoe, Konstantinovsk and Tardansk deposits), or p-type (Saralinsk, Balakhchinsk, Lisogorsk and Medvezhe) or p- and n- pyrite types in equal numbers (Znamenitinsk, Kuznestsck, Javarskoe, Maslovskoe and Podlunni deposits). Pyrite can be rarely observed with electronic conductivity (Tarchinsk) [4, 9].

It has been determined that in most deposits there is a regular exchange of pyrite conductivity type from electronic to electronic-p-type and / or p-type in relation to the transition from the early high-temperature mineral associations to the final deposit formation stages (figure 5). Thermal EFM of pyrites changes areally: from the upper part of orebodies to the bottom part where the exchange of pyrite conductivity is from p-type to electronic-p-type and/or electronic. Moreover, pyrites of

productive mineral associations and highly – gold enriched areas of orebodies exhibit mixed conductivity type (table 1).

Table 1. Evaluation criteria of ore zone erosion of orebodies in gold-ore deposits and their prospectivity at depth based on pyrite typomorphic features.

Pyrite location	Crystallomorphology	Impurity-elements	Thermal EMF
Supraore pyrite	Morphologically simple crystals (2-3 -type), often cubic habit; crystal face Грани {210}, {111}, {321} weakly developed	Hg, Ba, Sb and other light mobile elements; increased concentration of Ag, Pb, Cu and As (comparable to metacrystals from ore-free zones); content of gold: $Au \cdot 10^{-5} - n \cdot 10^{-4} \%$	P-type conductivity (90 % and more)
Pyrite from upper part of orebodies	Crystals – 2-5 types (rarely more); morphological types- cubic and/or pentagonal-dodecahedral habits; often no combined crystal faces {321}	Increased concentration of Hg, Ba, Ag and Sb, rarely As; no and/or trace content of Co, Ni, Ti and Cr; Au content ranges from $n \cdot 10^{-4}$ to $n \cdot 10^{-3}$, however, a sequence higher in near-ore pyrite	Predominate p-type conductivity (75–90%)
Pyrite from mid part of orebodies	Maximum number of morphological crystal types (30 and more); sharp combination instability; irregular developed crystal faces; number of crystal habits is maximum, predominately developed cubic and/or pentagonal-dodecahedral	Significant concentration of Pb, Zn, Cu, As and other elements and their distribution parameter (\bar{X}, S^2, V); Au content – $n \cdot 10^{-3}$ and higher	Electronic-p-type conductivity
Pyrite from bottom part of orebodies	Number of morphological crystal types 2-5: cubic and/or pentagonal-dodecahedral habits; no combination of crystal faces {321} and other with complex indexes	Minimum content of Au ($n \cdot 10^{-5} - n \cdot 10^{-4} \%$), absence of Hg, Ba, Sb; increased concentration of Co, Ni, Cr, Ti, V, rarely, As	Predominate electronic conductivity (80–90%)

Note: Pyrites from near-ore rocks (according to ore zone erosion of orebodies) are allied to ore pyrites in relation to their typomorphic features. The only difference very simple crystal morphology and low concentration of impurity elements, the content of which increases towards to the orebody.

4. Conclusion

The detected changes in the typomorphic properties of pyrites are consistent with the mineralogical and geochemical zoning of orebodies and deposits. This fact makes it possible to evaluate the ore zone erosion level, potential mineralization and its extension depth and identify blind ore bodies. In this case, pyrites could be used as a mineralogical criterion in prospect evaluation survey exploration to mine gold.

Acknowledgements

The investigations were supported by National Research Tomsk Polytechnic University, project №: 114-2014. The research was performed with the financial support from Government project “Nauka”, №. 1.1488.2015

References

- [1] Ananyev Yu S 1989 Tipomorfizm pirita, kak priznak orudnenija v odnom iz zolotorudnyh mestorozhdenij chernoslancevyh tolshhah Kalby *Geology and mineral resources in Western Siberia platform* 174–175
- [2] Andreev Yu S 1992 *Pyrite in gold-bearing deposits* (Moscow: Nauka) p 144
- [3] Evzikova N Z 1984 *Prospecting crystallomorphology* (Moscow: Nauka) p 143
- [4] Korobeinikov A F, Narseev V A, Pshenichkin A Ja, Revjakin P S and Arifulov Ch H 1993 *Pirity zolotorudnyh mestorozhdenij (svojstva, zonal'nost', prakticheskoe primenenie)* (Moscow: CRGE Institute of Ferrous and Nobel Metals) p 213
- [5] Korobeinikov A F and Pshenichkin A Ja 1985 Specific typomorphic features of pyrite in gold-ore deposits *Geochemistry* **1** 93–104
- [6] Lukyanova E V 1991 Tipomorfnye osobennosti pirita i arsenopirita odnogo izolotorudnyh mestorozhdenij Kazahstana *Rudonosnye metasomaticheskie formacii Urala* 66–68
- [7] Prokhorov V G 1970 *Pyrite (geochemistry, mineralogy, economic and industrial applications)* (Krasnoyarsk: CSRI of Geology, Geophysics & Mineral Resources) p 168
- [8] Pshenichkin A Ja 1989 Kristallomorfologija pirita i ejo ispol'zovanie v praktike poiskovo-razvedochnyh rabot na zoloto *Geology and geophysics* **11** 65–75
- [9] Pshenichkin A Ja 1977 Termojelektricheskie svojstva piritov nekotoryh zolotorudnyh mestorozhdenij razlichnyh tipov *TPU Izvestiya* **247** 74–78
- [10] Pshenichkin A, Timkin T, and Oscina Yu 2015 Noble metals in rocks and ores of Maysko-Lebed ore field (Mountain Shoriya) *IOP Conf. Ser.: Earth Environ. Sci.* **24** 012025