

Formalization of hydrocarbon conversion scheme of catalytic cracking for mathematical model development

G Nazarova^{1,2}, E Ivashkina^{1,3}, E Ivanchina^{1,4}, S Kiseleva^{1,5} and V Stebeneva^{1,6}

¹ Department of Fuel Engineering and Chemical Cybernetics, National Research Tomsk Polytechnic University, 30 Lenin Ave., Tomsk, 634050, Russia

E-mail: ² silko@tpu.ru, ³ ivashkinaen@tpu.ru, ⁴ ied@tpu.ru, ⁵ svk22077@mail.ru, ⁶ stebeneva_valeriya@mail.ru

Abstract. The issue of improving the energy and resource efficiency of advanced petroleum processing can be solved by the development of adequate mathematical model based on physical and chemical regularities of process reactions with a high predictive potential in the advanced petroleum refining. In this work, the development of formalized hydrocarbon conversion scheme of catalytic cracking was performed using thermodynamic parameters of reaction defined by the Density Functional Theory. The list of reaction was compiled according to the results of feedstock structural-group composition definition, which was done by the n-d-m-method, the Hazelvuda method, qualitative composition of feedstock defined by gas chromatography-mass spectrometry and individual composition of catalytic cracking gasoline fraction. Formalized hydrocarbon conversion scheme of catalytic cracking will become the basis for the development of the catalytic cracking kinetic model.

1. Introduction

At the present stage of fuel chemical technology development the advanced petroleum refining processes are the most significant for refining, because the industrial sector is focused on the efficient use of natural fuel-power resources and the demand in fuel is increasing every year.

Currently, the construction of modern technologies for advanced petroleum processing such as hydrocracking, catalytic cracking, hydrotreating of heavy hydrocarbon fractions, hydrodewaxing and hydroisomerization is organized at the major refinery plants. Modernization of the refinery industry is principally connected with the aim to create a competitive refining and petrochemical sector, corresponding the high level of modern foreign refineries (oil refining depth – 85-95%).

Advanced petroleum processing is aimed to the production of light hydrocarbon fractions (mainly gasoline and diesel fractions) from the heavy fraction of petroleum feedstock.

Exploitation of advanced petroleum processing units in the energy and resource-efficient modes should be carried out with the application of the mathematical models which are based on the hydrocarbon conversion mechanism reflecting the physical and chemical essence of process [1, 2].

It is important to take into account factors that influence the quality and quantity of production (multi-component of feedstock, catalyst types, process conditions, associativity of flowsheet devices and others.) during the development of mathematical model of the reactor. In addition, in petroleum fractions with boiling point above 200 °C the cyclic hydrocarbons are of mixed (hybrid) nature. Usually cyclic hydrocarbons contain the side paraffinic chains and, simultaneously, a part of naphthenic and aromatic rings.



In general, the mathematical model of reactor represents a set of hydrodynamic and kinetic components supplemented by the material and heat balance equation.

The aim of this work is to develop the formalized hydrocarbon conversion scheme in advanced petroleum processing on the example of the catalytic cracking vacuum distillate on the basis of which the mathematical model of the catalytic cracking reactor-regenerator will be further developed.

Technological aggregation on the certain characteristics is generally applied during the development of mathematical description of the refining process. Reaction system components are aggregated according to their belonging to the specific hydrocarbon series [3,4] and the least probable reaction is excluded from the list in order to simplify schemes. This approach is characterized by the reaction mechanism with the average reactivity of hydrocarbon groups.

Since the difficulty of advanced petroleum processing modeling lies in the determination of group composition of heavy hydrocarbon fraction, the most popular approach to the formalization of such processing scheme will be the technological aggregation on the fraction boiling point [5–10]. However, the chemical composition of the fractions is diverse and the scheme does not take into account the different reactivity within the selected groups.

There are combined models which take into account not only interactions of pseudocomponents on the fractional composition but also the chemical conversion of the main hydrocarbon groups of the catalytic cracking reaction system [11–14] and also deactivation functions, diffusion effects, chemical reaction and etc. [15–22].

The selection of the formalization level of hydrocarbon chemical conversions is an important stage in the development of mathematical description, which is preceded by the stages of studying of the theoretical foundations and experimental data on the hydrocarbon composition of installation streams, analysis of technological modes of reactor operation and the identification of features of industrial units exploitation, laboratory investigation (such as chromatography mass spectrometry, chromatography, n-d-m-method, Hazelvud-method) and thermodynamic analysis of the catalytic cracking reactions.

2. Determination of quality and structural-group composition of catalytic cracking feedstock

Data concerning quantitative and qualitative group composition of catalytic cracking feedstock and individual composition of gasoline fraction is required for the development of the formalized hydrocarbon conversion scheme in the catalytic cracking.

Liquid adsorption chromatographic separation on silica gel ASA with a grain size of 0.2 - 0.3 mm was performed according to VNII NP algorithm with the aim to determine the structural-group composition of catalytic cracking feedstock. Hydrocarbon fractions were extracted sequentially by desorption method with the application of solvents with different polarity (hexane, toluene and hexane, ethyl alcohol and toluene). The laboratory investigation results of catalytic cracking feedstock showed that paraffinic and naphthenic content equal to 61.20% wt, aromatic content of 35.57% wt. and resin content of 3.23% wt.

Hydrocarbons were separated by the refractive index on paraffin-naphthenic and aromatic fraction. Measurement accuracy of refractometer IRF-22 was tested by hexane refractive index. Structural-group composition of paraffin-naphthenic fractions was determined by the n-d-m-method, for aromatic hydrocarbon fraction by the Hazelvud-method (table 1).

Besides, the research in the determination of molecular weight and total sulfur content in catalytic cracking feedstock was performed. The devices CRYETTEWR, determining the freezing point of the samples and X-ray fluorescence energy-dispersive analyzer of sulfur "SPECTROSCAN SL», were applied for this purpose. The sulfur content and molecular weight of the feedstock is 0.0461% wt. and 382.43 g/mol respectively.

Mass-spectra of the catalytic cracking feedstock components were obtained in the laboratory by gas chromatography-mass spectrometry for determining qualitative composition of raw materials. Chromatography-mass spectrometer Hewlett Packard 6890 Gas Chromatograph System with 5973 Mass Selective Detector with GC Chemstation software was applied as the analytical equipment.

Table 1. Structural-group composition of catalytic cracking feedstock.

Parameter	Paraffin-naphthenic fraction	Aromatic fraction
Carbon content in the aromatic structures (Ca)	2.59	27.52
Carbon content in the naphthenic structures (Cn)	31.27	55.73
Carbon content in paraffinic structures (Cp)	66.14	16.76
Average number of aromatic rings (Ka)	0.14	1.40
Average number of naphthenic rings (Kn)	2.05	3.90
Total number of rings (Ko)	2.19	5.30

According to the structural group composition data of paraffin and naphthenic fraction of catalytic cracking feedstock (n-d-m-method), the fraction contains some amount of aromatic structures. It can be explained by the fact that the sorption of this structure is substantially similar with the sorption of naphthenes and that the small amount of this structure is washed out by the solvent. Content of aromatic structure is 2.59 % in catalytic cracking feedstock. Content of carbon quantity in naphthenic structures of feedstock is 31.27 %, the average number of naphthenic rings - 2.05 units.

According to the results of gas chromatography-mass spectrometry, the paraffin hydrocarbons are presented by hydrocarbons with the carbon number C_{13} – C_{40} . Naphthenic hydrocarbons are presented by mono- and polycycloalkanes with long alkyl substituents of normal and iso-structure with carbon atoms in the alkyl substituents alkilnyh C_1 – C_{25} (figure 1).

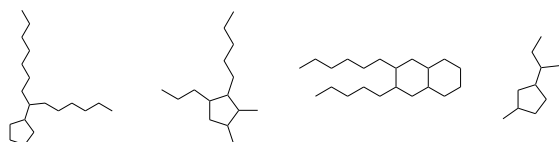

Figure 1. Examples of naphthenic hydrocarbons molecular structures (methylalkylcyclohexanes, bicycloalkanes, dimethylalkylcyclohexanes, etc.)

According to the analysis of aromatic concentrates by the Hazelvude-method the aromatic structure is presented by hybrid structures. In aromatic fractions isolated from catalytic cracking feedstock the average number of naphthenic rings (3.9 units) is more than the number of aromatic rings (1.4 units). The total content of rings in catalytic cracking feedstock is 5.3 units. The carbon content in aromatic and naphthenic structures of feedstock is 27.52 and 55.73 % respectively. Carbon content in paraffinic fragments of aromatic concentrate indicates the presence of alkyl substituted of aromatic hydrocarbons and naphthenes; the content of paraffins fragments – 16.76%. The simplest representatives of aromatic hydrocarbons of catalytic cracking feedstock are monoalkylbenzenes, methylalkylbenzenes, methyl and substituted naphthalenes, monoaromatic steroids, etc.

Laboratory investigation by the gas-liquid chromatography was conducted to determine an individual composition of catalytic cracking gasoline fraction using a gas chromatograph "HROMATEK - CRYSTAL 5000" version 2 with a flame ionization detector and capillary column DV -1 100·0.25·0.5. Software "Chromatec analyst" for the management, collection and processing of chromatographic information was used. The results of determining the individual composition of gasoline fraction was processed using the software developed at the Department of Fuel Engineering and Chemical Cybernetics of Tomsk Polytechnic University (table 2). The program is destined for processing of chromatographic data to determine the allocation of high-octane components of gasoline and aggregation of gasoline hydrocarbons according to the different chemical characteristics (molecular structure, reactivity, octane number etc.)

3. Thermodynamic analysis of the catalytic cracking reactions

The feedstock of advanced petroleum processing is characterized by the high boiling point of fractions (350-570 °C). Thermodynamic parameters of reactions involving the high molecular weight hydrocarbons are virtually absent in directory. Furthermore, it is also important to take into account the real operating conditions of industrial unit at calculation of reactions thermodynamic parameters, as well as the interaction effects of hydrocarbons molecules with the reaction mixture molecules in the

Table 2. Individual and combined components of the catalytic cracking gasoline fraction.

Component	% wt	Component	% wt	Component	% wt
propane	0.082	trimethylhexanes	0.633	tetramethylbenzenes	1.303
n-butane	0.331	isoaraffins C ₉	1.214	aromatics C ₁₀	6.213
n-pentane	0.504	methylnonanes	0.957	aromatics C ₁₁₊	5.416
n-hexane	0.586	dimethyloctanes	0.835	butene-1	0.483
n-heptane	0.411	isoaraffins C ₁₀	0.438	butene-2	1.422
n-octane	0.382	isoaraffins C ₁₁₊	1.394	isobutylene	0.468
n-nonane	0.236	cyclopentane	0.114	olefins C ₄	0.007
n-decane	0.215	methylcyclopentane	1.939	pentene-2	0.959
paraffins C ₁₁₊	0.284	ethylcyclopentane	0.120	pentene-1	0.327
i-butane	0.984	dimethylcyclopentanes	0.460	Methylbutenes-1	0.933
i-pentane	3.900	ethylmethylcyclopentanes	0.133	2-methylbutene-2	1.741
2-methylpentane	3.149	trimethylcyclopentanes	0.474	cyclopentene	0.243
3-methylpentane	2.095	n-propylcyclopentane	1.906	olefins C ₅	0.031
2,2-dimethylbutane	0.013	cyclohexane	0.706	hexene-1	0.166
2,3-dimethylbutane	0.713	methylcyclohexane	1.428	hexene-2	0.292
2-methylhexane	2.537	1,2-dimethylcyclohexanes	0.226	hexene-3	1.003
3-methylhexane	1.852	1,3-dimethylcyclohexanes	0.302	methylcyclopentenes	0.662
3-ethylpentane	0.128	naphthenes C ₈	0.968	methylpentenes-1	0.613
2,3-dimethylpentane	0.073	naphthenes C ₉	1.375	methylpentenes-2	2.058
2,4-dimethylpentane	0.518	naphthenes C ₁₀₊	1.148	cyclohexene	0.077
2,2,3-trimethylbutane	0.019	benzene	0.583	olefins C ₆	0.896
2-methylheptane	1.094	toluene	3.295	heptene-1	0.042
3-methylheptane	1.277	ethylbenzene	1.355	heptene-3	0.323
3-ethylhexane	0.299	i-propylbenzene	0.063	methylhexenes	0.647
2,3-dimethylhexane	0.12	n-propylbenzene	0.517	dimethylpentenes-2	0.156
2,4-dimethylhexane	0.352	1,3,5-trimethylbenzene	0.887	olefins C ₇	1.632
2,3,4-trimethylpentane	0.011	1,2,4-trimethylbenzene	2.675	octene-2	0.067
methylethylpentanes	0.435	1,2,3-trimethylbenzene	0.682	octene-3	0.098
methyloctanes	1.982	dimethylbenzene= xylols	6.154	olefins C ₈	0.771
dimethylheptanes	0.598	methylethylbenzenes	3.251	olefins C ₉₊	1.705

calculation of the thermodynamic parameters of reactions.

The software Gaussian which implements the quantum-chemical methods of calculation of the molecule electronic structure and provides adequacy and sufficient accuracy of calculations for chemical reactions simulation of refinery processing was used to solve these difficulties. The ab initio (non-empirical) method DFT – Density Functional Theory was used as a main calculation method. Theoretical approximation was B3LYP model (Becke's density functional theory (B3) with theoretical approach using Lee, Yang and Parr electron correlation (LYP), 3-21G basis.

The list of anticipated catalytic cracking reactions was made on the basis the laboratory investigations to determine the structural-group and quality composition of feedstock and individual composition of the gasoline fraction.

The calculation results of the average values of the thermodynamic parameters of the most probable catalytic cracking reactions at the process conditions ($T = 504\text{ }^{\circ}\text{C}$, $P = 0.108\text{ MPa}$) are presented in table 3. The values of Gibbs energy reaction (ΔG) characterizes the probability of reaction and its value is necessary for formalization of the hydrocarbon chemical transformations scheme, which will be the foundation to the catalytic cracking kinetic model.

According to the calculated thermodynamic values, the reactions of high molecular weight paraffins cracking ($\Delta G = -76.26\text{ kJ/mol}$), hydrogen transfer ($\Delta G = -140.24\text{ kJ/mol}$), dehydrogenation of naphthenes ($\Delta G = -114.33\text{ kJ/mol}$), dealkylation of aromatic hydrocarbons ($\Delta G = -76.39\text{ kJ/mol}$) and naphthenes ($\Delta G = -107.65\text{ kJ/mol}$) as well as coke formation reactions ($\Delta G = -597.2\text{ kJ/mol}$) are having the most thermodynamic probability.

Table 3. The average values of the thermodynamic parameters of catalytic cracking reactions

Hydrocarbon groups	ΔH , kJ / mol	ΔG , kJ / mol
Cracking of high molecular weight n-paraffins C_{13} – C_{40}	69.46	–76.26
Cracking of high molecular weight n-paraffins with formation of isoparaffins	66.96	– 66.28
Cracking of medium weight n-paraffins and C_5 – C_{12}	73.60	– 55.63
Isomerization of medium weight paraffins C_5 – C_{12}	–1.78	– 0.56
Cracking of olefins;	92.72	–32.36
Dealkylation of naphthenes;	118.14	–107.65
Hydrogen transfer;	74.26	–140.24
Dealkylation of aromatic hydrocarbons;	109.68	–76.39
Dehydrogenation of naphthenes;	210.68	–114.33
Cyclization of olefins to naphthenes	–53.8	–7.54
Polycondensation and coke formation	104.89	–597.20

4. Development of formalized hydrocarbon conversions scheme in the catalytic cracking

Formalized hydrocarbon conversions scheme in the catalytic cracking was composed according to the results of thermodynamic analysis taking into account the reversibility of reaction. Detailed hydrocarbon conversion scheme with taking into account the feedstock components, light and heavy gasoil are presented in figure 2.

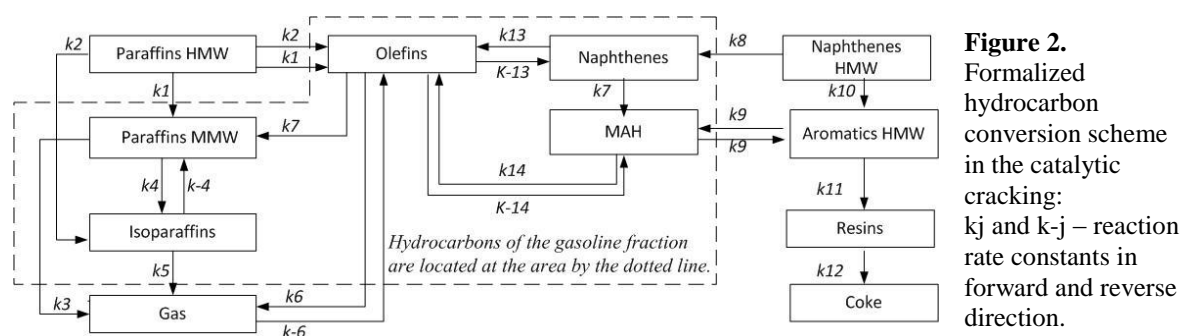

Figure 2. Formalized hydrocarbon conversion scheme in the catalytic cracking: k_j and $k-j$ – reaction rate constants in forward and reverse direction.

Paraffinic hydrocarbons are represented by two groups in the formalized hydrocarbon conversion scheme: "Paraffins MMW" group contains the normal paraffins of gasoline fraction C_5 – C_{12} and "Paraffins HMW" group contains paraffinic hydrocarbons of vacuum distillate C_{13} – C_{40} . Such distribution of paraffinic hydrocarbons on groups was based on the analysis results of catalytic cracking feedstock by gas chromatography-mass spectrometry, analysis of the gasoline fraction by gas chromatography and also according to the detailed thermodynamic analysis of the cracking reactions.

Separation of the paraffinic hydrocarbon feedstock on iso-paraffins and normal paraffins within the group "Paraffins HMW" is not provided due to the complexity of their quantitative determination. However, formalized hydrocarbon conversion scheme takes into account the formation possibility of isoparaffins of gasoline fractions from the feedstock that is connected with the carbonium ion mechanism of hydrocarbon conversion.

Unsaturated hydrocarbons was combined in "Olefins" group due to the difficulty of olefinic and diene hydrocarbon identification in the heavy fractions of petroleum feedstock. Olefin hydrocarbons of gasoline fraction are represented by C_3 – C_{13} hydrocarbons according to the chromatographic analysis results.

Aromatic hydrocarbons according to conversion scheme are divided in two groups: the "MAH" group includes aromatic hydrocarbons of gasoline fraction C_6 – C_{13} ; the "AH HMW" group is presented by the more complex aromatic hydrocarbon of feedstock, light and heavy gasoil with long alkyl substituents of normal and iso-structure.

According to conversion scheme, naphthenic hydrocarbons are divided in two groups: «Naphthenes» group contains the naphthenic hydrocarbons of gasoline fraction C₅–C₁₁; "Naphthenes HMW" group is presented by the more complex naphthenic hydrocarbon of feedstock, light and heavy gasoil (mono- and polycykloalkanes with long alkyl substituents of normal and iso-structure) with carbon number in alkyl substituents C₁–C₂₅.

According to the developed conversion scheme, reaction of coke formation occurs through successive conversion of complex naphthene-aromatic structures with further condensation of resins.

5. Conclusion

Compiling the formalized hydrocarbon conversion scheme and evaluation of their reactivity are an important stage in mathematical description development as the accuracy of the model calculations depends on the level of detail of the chemical reactions mechanism. Selected level of the catalytic cracking reaction mechanism formalization provides the recording of feedstock hydrocarbon groups to hydrocarbons of gasoline fraction conversions, light and heavy gasoil and coke in the kinetic model. Thus, the kinetic model remains sensitive to the changes of feedstock composition and at the same time allows estimating the yield and group composition of the main cracking product.

References

- [1] Frantsina E, Ivashkina E, Ivanchina E and Romanovsky R 2014 *Chemical Engineering Journal* **238** 129–39
- [2] Kang X and Guo X 2013 *Energy Sources Part A* **35** 1921–28
- [3] Belinskaya N, Ivanchina E, Ivashkina E, Frantsina E and Silko G 2014 *IOP Conf. Ser.: Earth Environ. Sci.* **21** 012030
- [4] Fernandes J, Verstraete J, Pinheiro C, Oliveira N and Ribeiro F. 2007 *Chemical Engineering Science* **62** 1184–98
- [5] Baudrez E., Heynderickx G.J., Marin G.B. 2010 *Chemical engineering research and design* **88** 290–303
- [6] Dagde K and Puyate Y 2012 *IJERA* **2** 557–68
- [7] Hua Zhou, Jianxiang Lu, Zhikai Cao, Jia Shi, Ming Pan, Wei Li and Qingyin Jiang 2011 *Fuel* **90** 3521–30
- [8] Sildir H, Arkun Y, Cakal B, Gokce D and Kuzu E 2012 *Journal of Process Control* **22** 1956–65
- [9] Martinez J and Ancheyta J 2012 *Fuel* **100** 193–99
- [10] Varshney P, Kunzru D and Gupta S 2014 *Indian Chemical Engineer* **21**
- [11] Barbosa A, Lopes G.C., Rosa L.M., Mori M., Martignoni W.P. 2013 *Chemical engineering transactions* **32** 637–42
- [12] Randolph A 1988 *Academic Press* 231–54
- [13] Lan X, Xu Ch, Wang G, Wu L and Gao J 2009 *Chemical Engineering Science* **64** 3847–58
- [14] Behjata Y., Shahhosseini S. and Hashemabadi S.H. 2011 *Chemical engineering research and design* **89** 978–89
- [15] Sedighi M., Keyvanloo K. and Towfighi J. 2013 *Fuel* **109** 432–38
- [16] Bartholomew C and Fuentes G 1997 *Elsevier* 695
- [17] Lopez-Isunza F 2001 *Studies in Surface Science and Catalysts* **134** 187–99
- [18] Froment G 2014 *Current Opinion in Chemical Engineering* **5** 1–6
- [19] Fu'nez A, Thybaut J, Marin G, Sa'nchez P, De Lucas A and Valverde J 2008 *Applied Catalysis A: General* **349** 29–39
- [20] Choudhury I R, Hayasaka K., Thybaut J., Narasimhan C.S.L., Denayer J.F.M., Martens J.A. and Marin G.B. 2012 *Journal of Catalysis* **290** 165–76
- [21] Vandegheuchte B, Thybaut J, Martinez A., Arribas M.A. and Marin G. 2012 *Applied Catalysis A: General* **441–442** 10–20
- [22] Deglmann P. V., Schafer A., Lennartz C. 2015 *International Journal of Quantum Chemistry* **115** 107–36