

## Plasma treatment of heat-resistant materials

V A Vlasov<sup>1,2</sup>, P V Kosmachev<sup>1</sup>, N K Skripnikova<sup>1</sup>, K A Bezukhov<sup>1</sup>

<sup>1</sup>Tomsk State University of Architecture and Building, Tomsk, 634003, Russia

<sup>2</sup>National Research Tomsk Polytechnic University, Tomsk, 634050, Russia

E-mail: [pvkosm@gmail.com](mailto:pvkosm@gmail.com)

**Abstract.** Refractory lining of thermal generating units is exposed to chemical, thermal, and mechanical attacks. The degree of fracture of heat-resistant materials depends on the chemical medium composition, the process temperature and the material porosity. As is known, a short-term exposure of the surface to low-temperature plasma (LTP) makes possible to create specific coatings that can improve the properties of workpieces. The aim of this work is to produce the protective coating on heat-resistant chamotte products using the LTP technique. Experiments have shown that plasma treatment of chamotte products modifies the surface, and a glass-ceramic coating enriched in mullite is formed providing the improvement of heat resistance. For increasing heat resistance of chamotte refractories, pastes comprising mixtures of Bacor, alumina oxide, and chamot were applied to their surfaces in different ratios. It is proved that the appropriate coating cannot be created if only one of heat-resistant components is used. The required coatings that can be used and recommended for practical applications are obtained only with the introduction of powder chamot. The paste composition of 50% chamot, 25% Bacor, and 25% alumina oxide exposed to plasma treatment, has demonstrated the most uniform surface fusion.

### 1. Introduction

The use of plasma technologies in different industries is being constantly widened due to a range of advantages over the traditional treatment of materials. Thanks to plasma generation units, it has become possible to apply the powerful plasma energy to surfaces that, in turn, intensifies the chemical reaction rate. It was proved that plasma treatment enhances the existing properties of materials and adds new ones. The description of the low-temperature plasma (LTP) technique used for the surface modification of diverse materials found in the literature, presents the results of obtaining protective and decorative properties of plasma-treated surface of materials [1-12].

The importance of heat-resistant materials for the industrial use is constantly grows. The quality of these materials mostly depends on the development of productions, especially, ferrous and nonferrous metallurgy, electrical power engineering, and chemical, gas, and glass industries. Heat-resistant materials can be used at various temperature conditions and with various media. Some of them contact with different types of melts, such as glass, sludge, metal and are subjected to both physical and chemical corrosion. Therefore, the density, strength, a certain chemical composition are the main requirements for heat-resistant materials. Others are used only in gaseous atmosphere, i.e. in less aggressive medium. Some materials are intended for a multiple alternating heating and cooling, and thus, must possess a high thermal resistance.

The material morphology (presence and nature of porosity) and the surface condition are also of great importance. The heat resistance of a porous material, especially when pores are big, open and interconnected, may turn to be several dozens of times lower than that of a dense and non-porous material. The proper grain composition and the increase of burning temperature of heat-resistant



materials result in pore size reduction and increase of the material corrosion resistance. Non-uniformities on the surface and cracks inside the material facilitate its corrosion. Still, there are no heat-resistant materials equally combining all operating characteristics necessary for a failure-free operation under any conditions. Each type of material is characterized by its own intrinsic properties that define its efficient use and scope of applications. The material is considered to be in operation at the furnace firing-up after its building or repair. Herewith, a temperature differential occurs in the body of material causing the respective mechanical stresses. In case the heating rate exceeds the allowable one for the given material and conditions, the material starts to crack and even crash. Upon completion of the furnace firing, heat-resistant materials are still experience the effect of high temperatures.

The reconstruction and construction of glass-, copper-, steel-melting and blast furnaces as well as cement kilns require a great number of diverse heat-resistant materials (refractories). Most of refractories are small piece materials which are used for hand-laid masonry of different configuration. In order to industrialize and optimize the period of brick-laying and lining of thermal generating units, the production of large refractory blocks, panels and unmolded refractories is being expanded. As is known, the production of small piece refractory materials and lining therefrom is rather labour-intensive and difficult to mechanize. The increase of refractory and heat-insulating material resistance enables the increase of the service life, decrease of thermal generating unit downtime due to repair of refractory lining, and increase of their productivity. Hence, the increase of the refractory service life by at least two times will allow their significant saving.

Refractory lining of thermal generating units and furnaces is subjected to chemical attack of fuel combustion products, melts, and materials that are melt or burned in furnaces. A degree of fracture of heat-resistant materials depends on the chemical composition of the medium, process temperature, and porosity of the material itself.

This paper mainly focuses on the creation of protective coating for heat-resistant chamotte products using the LTP technique.

## 2. Experimental

Chamotte refractory products were used in this experiment. Surfaces of specimens produced from the given heat-resistant materials were treated by LTP at different process conditions. The LTP treatment was provided by the laboratory plasma generator installed at the Department of Applied Mechanics and Material Sciences of Tomsk State University of Architecture and Building, Tomsk, Russia. Figure 1 shows the schematic layout of this plasma generator.

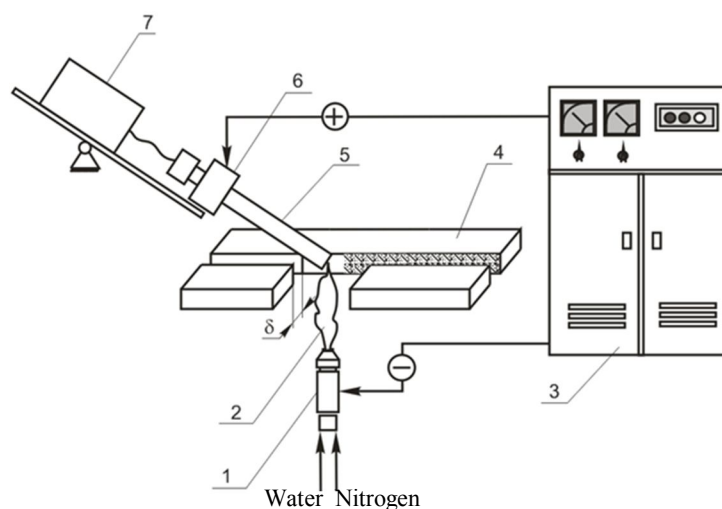

**Figure 1.** Schematic layout of plasma generator: 1 – cathode assembly; 2 – plasma arc; 3 – power source; 4 – workpieces; 5 – graphite anode; 6 – cooling unit; 7 – electric drive of electrode feeding.

At a short-term LTP exposure, the melt is formed on the surface of heat-resistant materials and then instantly frozen forming either a vitreous or a glass-ceramic coating. This process can be referred to plasma-chemical processes of non-equilibrium and local nature. Plasma-chemical processes differ

from common thermal processes by the reaction behavior, namely, missing or unifying some of phases [13].

The surface of workpieces was melted at different rate and power of the plasma generator [14-15]. Table 1 presents the quality of the modified surface depending on fusion modes.

**Table 1.** The quality of coatings depending on fusion modes

Type of material	Fusion mode		Porosity (%)	Outcome
	Power (kW)	Fusion rate (m/s)		
Chamot	60	0.13	1.6	Underburning
	80	0.13	1.2	Overburning, roughness
	80	0.17	0.8	Good-quality glass-ceramic coating
	80	0.19	1.1	Underburning

As Table 1 shows, that in treating chamotte products, the good-quality, i.e. low porosity coating is formed at 0.17 m/s fusion rate and 80 kW power of plasma generator.

With a view to increase the heat resistance of chamotte products, heat-resistant pastes having 1-1,5 mm thickness comprising a mixture of Bacor, alumina oxide, and chamot are applied to surfaces in different ratios. The preliminary investigations of different refractory compositions applied to chamotte products show that no coating is created in case if only one heat-resistant component (Bacor, alumina oxide, zirconium dioxide, mullite or zircon) is used. Also, one more regularity is observed. Coatings that can be recommended for practical applications are obtained only after the incorporation of broken chamotte in the paste composition. This provides a better adhesion between the coating and the base. Seven compositions are suggested for further research, comprising two or three components one of which is powder chamot (Table 2).

**Table 2.** Properties of modified surface of chamotte products depending of paste composition

No	Paste composition (wt.%)	Coating thickness (mm)	Adhesive strength (MPa)	Modified surface properties
1	Chamot -50 Bacor-25 Alumina oxide-25	1.5-2	3.32	Grass-ceramic uniform coating with vitreous drops
2	Chamot -25 Bacor -50 Alumina oxide -25	1-2	2.28	Non-uniform, porous coating with base visible
3	Chamot -50 Bacor -50	1-2	3.02	Rough coating; glass phase coagulation
4	Chamot -75 Bacor -25	1-2	2.08	Non-uniform, porous coating with base visible
5	Chamot -50 Bacor -75	1-2	2.01	Non-uniform, porous coating with base visible; glass phase coagulation
6	Chamot -50 Alumina oxide -50	1-2	-	No coating formation
7	Chamot -25 Bacor -25 Alumina oxide -50	1-2	-	No coating formation

It is shown that the most uniform coating is obtained at fusion of 50% chamot, 25% Bacor, 25% alumina oxide paste composition. At a higher content of Bacor in the paste composition, the glass phase coagulation is observed and the base of the workpiece becomes visible, while at a higher content of alumina oxide, the coating formation is not achieved.

Research results show that phosphate-based pates are well-applied to the surface and adhere to it

very strongly. However after the plasma treatment, coagulation of this coating is observed in the form of separate drops.

The strongest adhesion between the coating and the base is observed in the liquid glass-based coating. The experimental results show that the thickness of the paste to be applied must not be over 1 mm. Otherwise, it does not adhere to the base in the proper way, and the coating is cracked thereby decreasing the adhesive strength.

### 3. X-ray phase analysis

The structural and physicochemical transformations of the surface and contact layers were studied by the X-ray phase analysis. The analysis shows that chamotte product base is presented by high quartz, aluminum silicate  $\text{Al}_2\text{O}_3 \cdot \text{SiO}_2$  and mullite  $3\text{Al}_2\text{O}_3 \cdot 2\text{SiO}_2$  ( $d = 0,539; 0,377; 0,339; 0,270; 0,254; 0,221$  nm) (Fig. 2).

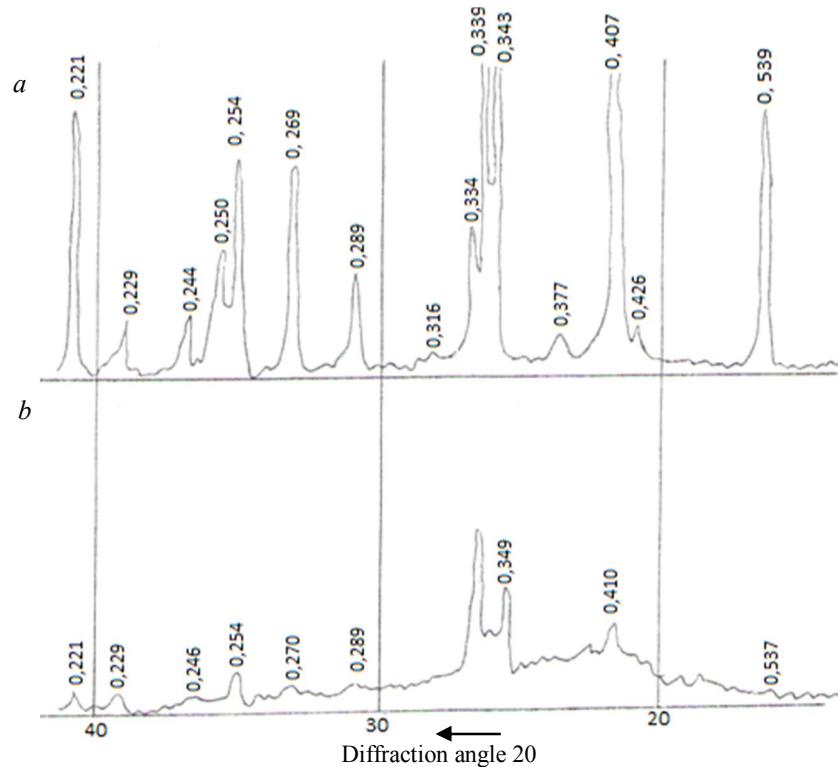

**Figure 2.** XRD pattern of chamot: *a* – chamot base material; *b* – fused coating

As a result of chamotte surface fusion as shown in Figure 2, a portion of the base material is transformed to the X-ray amorphous state. The decrease of mullite diffraction maximums indicates that these phases are transformed to the amorphous state, however, mullite has partially retained its crystallinity ( $d = 0.339; 0.349$ ).

As for aluminum silicate  $\text{Al}_2\text{O}_3 \cdot \text{SiO}_2$  ( $d = 0.244; 0.289; 0.377$  nm), the decrease of diffraction maximums indicates a transformation of this composition to a vitreous state.  $\alpha$ -quartz ( $d = 0.229; 0.407; 0.426$  nm) incorporated in the base material after fusion partially has transformed to the glass phase.

The X-ray phase analysis shows that after the fusion of chamotte base material, a glass-ceramic coating enriched in mullite, is formed on its surface indicating that its heat-resistance will be higher than that of the base material. As is known, the heat-resistance of chamotte is in the order of  $1600^\circ\text{C}$ , while the melting temperature of mullite is over  $1800^\circ\text{C}$ .

### 4. Conclusion

Experimental findings showed that the plasma treatment of heat-resistant specimens resulted in the formation of the glass-ceramic coating enriched in mullite that improves heat-resistance of the given products.

In order to increase heat-resistance of chamotte products, special paste compositions are required, namely comprising different ratios of Bacor, alumina oxide, and chamot. It was proved that the appropriate coating could not be created if only one of heat-resistant components is used. It was stated that paste composition of 50% chamot, 25% Bacor, and 25% alumina oxide produced the most uniform surface fusion.

### Acknowledgement

The authors acknowledge the Ministry of Education and Science of the Russian Federation for the financial support (Project # 11.351.2014/K).

### References

- [1] An'shakov A S, Volokitin O G and Urbakh E K 2012 *Rus. Phys. J.* **2**. 5–7.
- [2] An'shakov A S, Volokitin G G, Volokitin O G and Skripnikova N K 2014 *Elektrotekhnologicheskie ustanovki dlya plazmenno-termicheskoi obrabotki materialov* [Electrical engineering units for plasma treatment of materials]. Tomsk: TSUAB Publ.
- [3] Shershnev A A, Gaenko I S, Savel'chikova I L, Men'shelova G G and Borovskii Yu F 1987 *Refractories* **2**.105.
- [4] Fridment M G, Pershin V A, Gaenko I S and Karasev V P 1986 *Refractories* **6**. 121.
- [5] Sun Y, Liang Q, Chi H, Zhang Y, Shi Y, Fang, D, Li F 2014 *Fib. Pol.* **15** (1). 1-7.
- [6] Ye Y, Xu Y, Liu Y, Tu W, Liao J 2013 *Pol.Mat. Sc. Eng.* **29** (11). 187-190.
- [7] Kusano Y 2014 *J. Adh.* **90** (9). 755-777.
- [8] Yoshida S, Hagiwara K, Hasebe T, Hotta A 2013 *Surf. Coat. Tech.* **233**. 99-107.
- [9] Zille A, Oliveira F R, Souto P A P 2015 *Pl.Proc.Pol.* **12** (2). 98-131.
- [10] Peltekis N, Kumar S, McEvoy N, Lee K, Weidlich A, Duesberg G S 2012 *Carbon* **50** (2). 395-403.
- [11] Vesel A, Mozetic M 2012 *Vacuum* **86** (6). 634-637.
- [12] Yun J W 2013 *Plasm. Sc.Tech.* **15** (6). 521-527.
- [13] Volokitin G G, Skripnikova N K, Shilyaev A M and Petrochenko V V 2005 *Plazmennye tekhnologii v stroitel'stve* [Plasma technologies in construction]. Tomsk: TSUAB Publ.
- [14] Kosmachev P V 2014 *Vest. TSUAB* **6**.141–147.
- [15] Skripnikova N K, Kosmachev P V and Bezukhov K A 2015 Modifitsirovanie poverkhnosti shamotnykh ogneporov nizektemperaturnoi plazmoi [Surface modification of fireclay refractory by low-temperature plasma] Novosibirsk: Constr Mat. – 4S: Coll Papers. 211–214.