

Comparison of CuBr-laser frequency operation modes

A.I. Fedorov^a, D.V. Shiyanov^{a,b}

^aInstitute of Atmospheric Optics SB RAS
Academician Zuev square, 1, Tomsk 634055, Russia, E-mail: qel@iao.ru

^bNational Research Tomsk Polytechnic University
Lenin Avenue, 30, Tomsk 634050, Russia, E-mail: ime@tpu.ru

ABSTRACT

The results of a comparative study of CuBr-laser energy characteristics with a small active volume operating in pulse-periodic mode and dual pump pulses are presented. The advantages of these regimes in the range 5-100 Hz and 5-100 kHz for output power, the energy generation and efficiency of the laser are shown.

Key words: CuBr-laser, double-pulse mode, pulse-periodic mode, pulse repetition rate, output power, output energy

1. INTRODUCTION

The pulsed metal halide vapor lasers (MHVLs) are remarkable because they are capable to operate in a wide frequency range from units of hertz up to hundreds of kilohertz [1-3]. In practice, when solving the specific problems with the use of these lasers, the most general demands can be placed upon these lasers, including the pulse repetition frequency. In this case high energies and radiation powers or their specific values are required.

At present the most effective of all the MHVLs is a CuBr vapor laser. In the CuBr-laser high specific powers of 1.4 W/cm^3 and mean generation powers of 120 W are realized [4, 5]. These parameters were obtained in the pulsed-periodic mode at frequencies of 15-25 kHz in gas-discharge tubes (GDT) with small and large volumes, respectively. This mode combines the functions of warming up of an active laser zone, dissociations of molecules of metal halide and metal excitation. In contrast to this the maximum energy of 10 mJ and the specific generation energy of $45 \mu\text{J/cm}^3$ are realized in the low-frequency regime of double pump pulses of 5-100 Hz also in the GDT with large and small volumes [6-8]. In this case the first pulse is dissociating, and the second pulse is exciting and the warming up of the active zone is required.

In this case a considerable body of work has been carried out on the study of the frequency-energy characteristics of CuBr-lasers in the pulse-periodic mode and in the double pulse mode [1-3]. However, so far a comparative analysis has not been made of output characteristics of one GDT of CuBr-laser, operating at low frequencies (double pulse mode) and at high frequencies (pulse-periodic mode).

Taking this into account, in the presented paper we have made a comparison of such characteristics as the energy and the generation power, the specific energies and powers, the efficiency of CuBr-laser with small volume of active zone operating at frequencies of 5-100 kHz and of 5-100 Hz. Previously we in [9-11] have made the investigation of characteristics of such GDT in the regime of double pump pulses.

2. EXPERIMENTAL TECHNIQUES

Figures 1, 2 shows the construction of GDT and pumping scheme for investigating the frequency-energy characteristics of a CuBr-laser in the regime of double pump pulses and in the pulse-periodic regime.

The GDT diameter was 1 cm, the active zone length was 40 cm (the volume was 31.4 cm^3). The GDT was fitted with an outer oven. At the cold ends of the tube the inside electrodes and output windows were located. The resonator consisted of an aluminum mirror and a quartz plate. To the electrodes two pump pulses were applied, the time delay (t_d) between which can change from 25 to 250 μs . The first high-voltage power supply formed the dissociation pump pulses.

At the cost of varying of its operation capacity (C_d) from 3.4 to 11.5 nF one can obtain the voltage pulses with an amplitude up to 20 kV and the discharge current up to 700 A. The power supply made possible to put into discharge the specific dissociation energies (E_d) from 3 to 26 mJ/cm³. The second power supply realized the excitation of copper atoms. It could form the voltage pulses with an amplitude up to 10 kV and the discharge current up to 400A when changing the operation capacity (C_p) from 1.1 to 9.4 nF. The power supply provided the specific excitation energies (E_p) in the active medium from 2 to 12 mJ/cm³. As switches the thyratrons TGI1-1000/25 were used the laser has been in operation at the generation pulse repetition rate from 5 to 100 Hz.

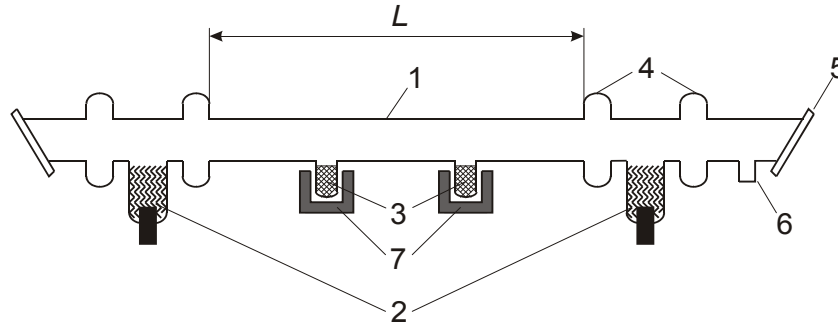

Fig. 1. Gas discharge tube of CuBr-laser design: 1 – operating channel, 2 – electrodes, 3 – container with CuBr, 4 – traps, 5 – output windows, 6 – HBr generator, 7 – heaters, L – active zone length.

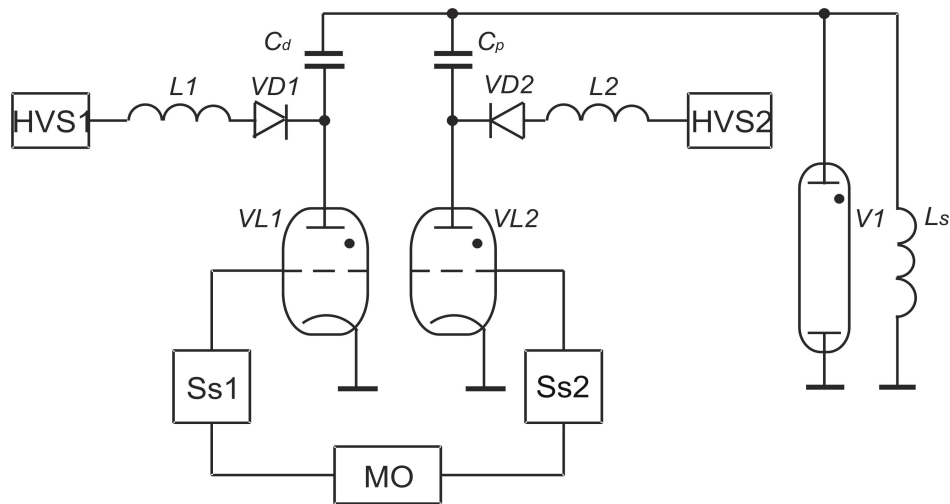

Fig. 2. Pump scheme of GDT: HVS1, HVS2 – high voltage supply; L1-VD1, L2-VD2 - charging inductance and diodes; VL1, VL2 – switches, C_d , C_p – working capacitor (dissociating and exciting), L_s – shunt inductance; V1 – gas discharge tube; MO – master oscillator; Ss1, Ss2 – switch start.

At the laser operation with high repetition rate up to 100 kHz, only one channel with the tacitron TGU1-1000/25 (VL2) was used as a switch in the pump scheme. In this case the operation capacity with the frequency increase from 5 to 100 kHz changed from 2200 to 110 pF. More details of the GDT construction and the pump circuit described in [12].

As a buffer gas in active medium neon at 30 torr pressure was used. Parameters of discharge plasma and laser radiation were recorded using a current sensor Pearson Current Monitors 8450, a voltage sample Tektronix P6015A, a photoreceiver FK-22 CPUM, an oscilloscope LeCroy WJ-324 and a calorimeter IMO-2N.

3. EXPERIMENTAL RESULTS

The investigation of the frequency-energy characteristics of CuBr-laser in the pulse-periodic mode was made using an addition of HBr and without it. This is determined by the fact that in such regime with the frequency increase

the cumulative effects play a negative role. Previously in [13] it was shown that the HBr addition could decrease the prepulse electron density and create the favorable conditions for laser level pumping. Because of this the laser generation power increased greatly [14]. In the regime of double pump pulses with the availability of large interpulse ranges the medium relaxes practically in full, and the effect of addition of halogenhydrogen in this case is reduced to a minimum. This is supported by the results [6] when using HCl in a CuCl-laser. Therefore in our work in the mode of double pulses HBr was not used.

Figure 3a shows the behavior of the output power in the frequency range from 5 to 100 kHz. In the entire frequency range the input power was at the level of 600 W due to the decrease of operation capacity. It is evident that the optimal repetition rates are in the range of 15-40 kHz. It is in this range we observe the great increase of power with the use of the HBr additive (0.2 torr) up to 1.8 times at the frequency of 30 kHz.

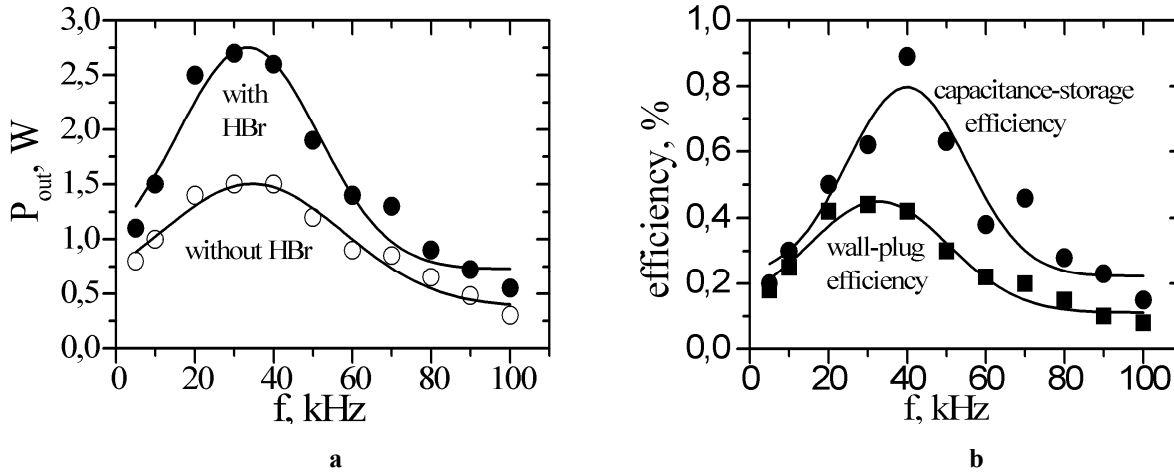

Fig. 3. Output power (a) and efficiency (b) of CuBr-laser with and without HBr addition in pulse-periodic mode.

Figure 3b shows the frequency dependences for the efficiency with the HBr addition, calculated based on the power taken from the high voltage supply (wall-plug efficiency) and based on the energy, accumulated in the operation capacity. An observed difference is mainly due to the losses in the switch. Thus, at low frequencies of 5-15 kHz, the power from the rectifier was characterized by 10-20%, and at frequencies more than 50 kHz it was characterized by 50%.

It should be mentioned that the wall-plug efficiency without HBr addition repeated the behavior of generation power and was respectively less than the wall-plug efficiency with HBr addition by 1.4-1.8 times. In the other case, the efficiencies calculated by the energy, accumulated in the operation capacity with the HBr addition and without it, differed from one another not considerably. It depends upon the fact that on the one hand, when putting HBr into operation, the voltage on the capacity increases (for example, from 6 to 8 kV- by 40 kHz) and so increases the pumping energy ($C \times U^2/2$). But, on the other hand, when putting HBr into operation, the radiation power and generation energy are increased that compensates the pumping energy increase owing to the voltage increase.

In papers [15, 16] we investigated the frequency-energy characteristics of CuBr-laser in the regime of double pumping pulses. In particular, Figure 4 shows the dependences of mean radiation power on the time delay between the dissociating and exciting pulses of excitation for different frequencies of repetition intervals at $C_d = 11.5$ nF, $C_p = 2.4$ nF (a) and the laser efficiency of the excitation pulse energy in case of adjusted and incompatible regimes of operation for $C_d = 11.5$ nF, $C_p = 1.1$ nF (b).

Mean radiation power increased greatly at the pulse repetition rate of 50 Hz and 100 Hz. In this case the range of optimum delays was 100-150 μ s. The maximum output power of 20 mW was recorded at the pulse repetition rate of 100 Hz. In [15,16] it was determined that for increasing the laser efficiency the regime was necessary, which could provide the optimum lead of the excitation pulse energy in the plasma of active laser medium. This is achieved by the impedance matching of pumping sources with plasma. In particular, at the cost of choosing the optimum voltage of an excitation pulse and its time delay relative to a dissociating pump pulse. It was also shown that the increase of the excitation pulse parameters can result in the laser energy increase up to a definite limit. Thereafter the mismatching occurs of the regime of energy lead in the plasma owing to the availability of damped oscillations of voltage and current with a large amplitude. Figure 4b shows the behavior of the laser efficiency for consistent ($U_{opt} = 6$ kV) and incompatible

($U_{\max} = 10$ kV) operation regimes. In the range of delays from 50 to 100 microseconds we can managed to increase the laser efficiency up to 1.2%, and the decrease of the excitation pulse amplitude resulted in the subsequent growth of the laser efficiency up to 1.5%.

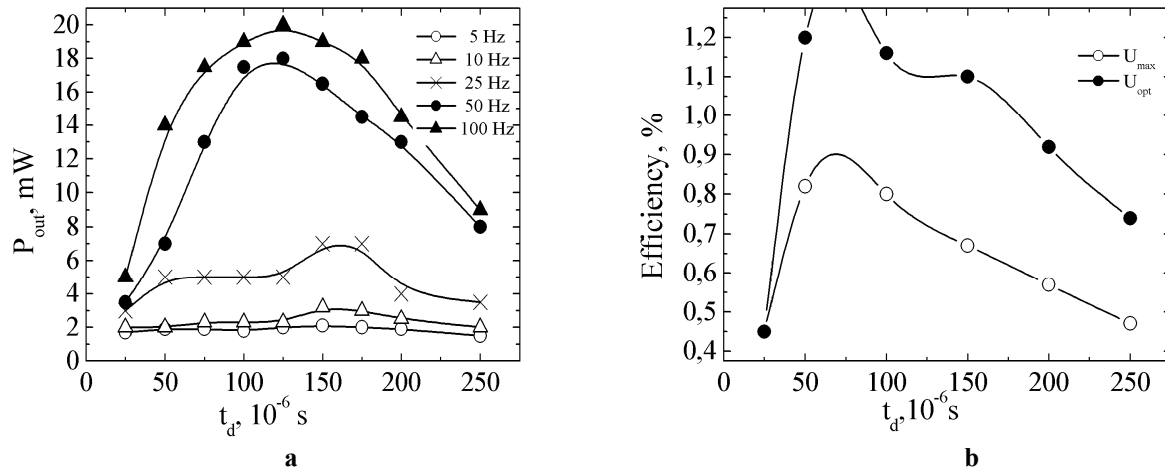

Fig. 4. Output power versus delay time between dissociation and excitation pulses for different pulse repetition rate (a) and efficiency of the excitation pulse energy with maximal and optimum voltage on the discharge for $E_d = 26$ mJ/cm³ (b).

When comparing the generation power and the CuBr-laser efficiency, operating in these two regimes, it is evident that the radiation power in the pulse-periodic regime at some frequencies exceeds the power of regime of double pump pulses by two orders. The laser efficiency in the pulse-periodic regime is typical for GDT of such volume and is close to 1%. The maximum laser efficiency of 1.5 % in the regime of double pump pulses was calculated based on the excitation pulse energy, and the energy is not considered, which is lead in the discharge from the source of pulse dissociation.

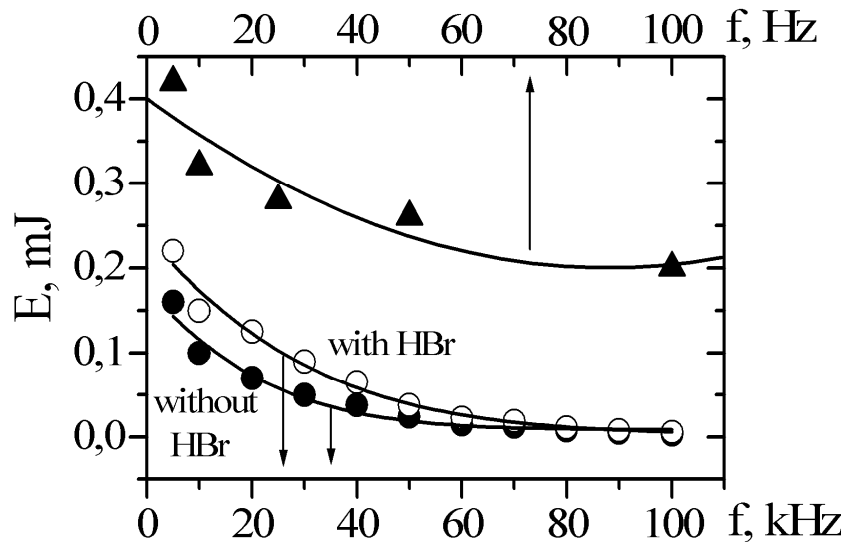

Fig. 5. Pulse energy versus pulse repetition rate for low-pulse and pulse-periodic modes.

A comparison of laser energy characteristics in the investigated regimes shows that the greatest radiation energies are obtained in the double pulse mode that is shown in Figure 5. In the double pump pulse mode the maximum radiation energy per pulse of 0.42 mJ ($13 \mu\text{J}/\text{cm}^3$) was observed at the pulse repetition rate of 5 Hz, which sharply decreased with its increase up to 25 Hz, and then the energy slowly decreased to 0.19 mJ ($6 \mu\text{J}/\text{cm}^3$) at the pulse

repetition rate of 100 Hz. In this case the optimum specific power of dissociation for these frequency regimes was equal to 12 mJ/cm^3 , and the specific energy of excitation was $2\text{-}6 \text{ mJ/cm}^3$. In the pulse-periodic regime the specific pumping power with the frequency increase up to 100 kHz decreased from 3.5 to 0.11 mJ/cm^3 , and the specific generation energy decreased from 7 to $0.19 \text{ }\mu\text{J/cm}^3$.

It should be noted that the CuBr-laser energy characteristics were obtained without special optimization of parameters of excitation pulses that is necessary for further increase of power. Primarily it is necessary to reduce parasitic energy deposited in the active medium of the laser after the excitation pulse.

4. CONCLUSION

A comparison of energy characteristics of CuBr-laser with a small volume of active zone, operating in the regime of double pump pulses at frequencies of $5\text{-}100 \text{ Hz}$ and in the pulse-periodic regime at frequencies of $5\text{-}100 \text{ kHz}$ has shown that the greatest radiation energies were obtained in the regime of double pump pulses, and the greatest radiation powers were obtained in the pulse-periodic regime. This should be taken into account, when in practice the specific requirements are imposed to this laser. For these regimes the energies of 0.42 and 0.22 mJ were obtained as well as the powers of 20 mW and 2.7 W . At a frequency of 50 Hz the capacities of excitation source of 1.1 nF and the voltage of 3 kV the laser efficiency in excitation reached 1.5% . In the pulse-periodic regime the laser efficiency, calculated by the energy, accumulated in the operation capacity, reached 0.89% .

REFERENCES

- [1] Little, C. E., [Metal Vapor Lasers: Physics, Engineering & Applications], John Wiley & Sons Ltd., Chichester, 620 (1998).
- [2] Batenin, V. M. Buchanov, V. V. Kazaryan, M. A. Molodykh, E. I. and Klimovskii, I. I., [Self-terminated metal vapor lasers], Nauchnaya kniga, Moscow, 544 (1998).
- [3] Evtushenko, G. S. Shiyarov, D. V. and Gubarev, F. A., [Metal vapor lasers with high-pulse repetition rate], Tomsk Polytechnic University Publishing house, Tomsk, 276 (2012).
- [4] Astadjov, D. N. Dimitrov, K. D. Little, C. E. Sabotinov, N. V. and Vuchkov, N. K., "A CuBr-laser with 1.4 W/cm^3 average output power," IEEE J. Quantum. Electron., 30 (6), 3158-3160 (1994).
- [5] Astadjov, D. N. Dimitrov, K. D. Jones, D. R. Kirkov, V. K. Little, C. E. Sabotinov, N.V. and Vuchkov, N.K., "Copper Bromide Laser of 120-W Average Output Power," IEEE J. Quantum. Electron., 33 (5), 705-709 (1997).
- [6] Nerheim, N. R. Vetter, A. A. and Russel, G. R., "Scaling a double-pulsed copper chloride laser to 10 mJ ," J. Appl. Phys., 49 (1), 12-15 (1978).
- [7] Liu, C. S. Feldman, D. W. Pack, J. L. and Weaver, L. A., "Kinetic processes in continuously pulsed copper halide lasers," IEEE J. Quantum. Electron., 13 (9), 744-751 (1977).
- [8] Abrosimov, G. V. Vasiltsov, V. V. Voloshin, V. N. Korneev, A. V. and Pismennyi, V. D., "Pulse generation on self-terminated copper atom transitions in copper halogenide vapors," Technical Physics Letters, 2 (9), 417-420 (1976).
- [9] Fedorov, A. I. Fedorov, V. F. and Shiyarov, D. V., "The Investigations of Low-Frequency CuBr-Laser Characteristics," Proc. V Conference on Interaction of the high-concentrated energy fluxes with materials in perspective technologies and medicine, 1, 263-265 (2013).
- [10] Fedorov, A. I. and Shiyarov, D. V., "Optimization of radiation parameters of the CuBr-laser operating in dual pulse mode," Proc. VI Conference on Interaction of the high-concentrated energy fluxes with materials in perspective technologies and medicine, 1, 257-261 (2015).
- [11] Fedorov, A. I. and Shiyarov, D. V., "Low-frequency CuBr laser," Atmospheric and oceanic optics, 28 (9), 859-863 (2015).
- [12] Andrienko, O. S. Gubarev, F. A. Dimaki, V. A. Ivanov, A. I. Levitsky, M. E. Sukhanov, V. B. Troitskii, V. O. Fedorov, V. F. Filonov, A. G. and Shiyarov, D. V., "New generation of CuBr lasers," Atmospheric and oceanic optics, 22 (10), 999-1009 (2009).
- [13] Isaev, A. A. Jones, D. R. Little, C. E. Petrash, G. G. Whyte, C. G. and Zemskov, K. I., "Characteristics of pulsed discharges in copper bromide and copper HyBrID lasers," IEEE J. Quantum Electron., 33 (6), 919-926 (1997).
- [14] Andrienko, O. S. Evtushenko, G. S. Zhdanev, O. V. Sukhanov, V. B. and Shiyarov, D. V., "Effect of HBr additives into the active media of copper-vapor and copper-halide lasers," Atmospheric and oceanic optics, 17 (2-3), 112-118 (2004).

- [15] Fedorov, A. I. and Shiyanov, D. V., "The possibility of increasing the efficiency of CuBr lasers in the regime of double pump pulses," *Technical Physics Letters*, 41 (8), 759–761 (2015).
- [16] Fedorov, A. I. and Shiyanov, D. V., "Low-frequency CuBr laser," *Atmospheric and oceanic optics*, 28 (11), [in Press].