

A.M. Ardalin

National Research Tomsk Polytechnic University
Tomsk, Russia

Current stabilizer of charging capacitive storage

For modern energy, intensive forms of development, nominating increased demands on quality indicators of power plants, are important. In this regard, the energy storage role increases, providing the solution of many problems of accumulation, storage, energy conversion, implementation of optimal operating conditions of equipment, consumers with non-default settings, etc.

In general under energy storage we mean a device that allows accumulating energy of any charge type during the period, and then transmitting a substantial portion of energy to the load during the discharge period.

The times of charge and discharge can vary greatly. Accordingly, there are several uses of storage.

Firstly, their main role may be reduced to the accumulation of excess energy when disconnecting a large part of consumers and the subsequent use of the stored energy during intense energy. At the same time, charge and discharge time is approximately equal.

Secondly, the primary purpose of energy storage devices is conversion of various types of energy

Thirdly, the energy storage devices, in the corresponding modes, provide the necessary parameters of transformation of a certain energy type.

If, for instance, in any type of storage the discharge time is much less than the charge time of the discharge time, therefore the storage power is many times larger than the power consumed by charging them with a primary source of energy, i.e. the storage device serves as the power transformer. Capacitive storage device can make current many times greater than when it is charging, and the inductive storage due to EMF when circuit commutation the voltage can be obtained much higher than the supply voltage.

In describing the capacitive storage devices using, as a rule, standard capacitors, the focus has shifted to the problem of optimal capacitor charging modes and rational matching characteristics of the systems elements with savings in dynamic modes. [1]

Block diagram of a switch-mode current stabilizer is shown on fig. 1. The first block of the power supply is called the rectifier and filter section. The second block in the diagram shows the symbols of a MOSFET and bipolar transistor. This section is called the high-frequency switching section and it uses either MOSFETs or bipolar transistors to convert the DC voltage to a high-frequency AC square wave. The incoming AC voltage is rectified to DC and then the high-frequency switching section changes it back to AC.

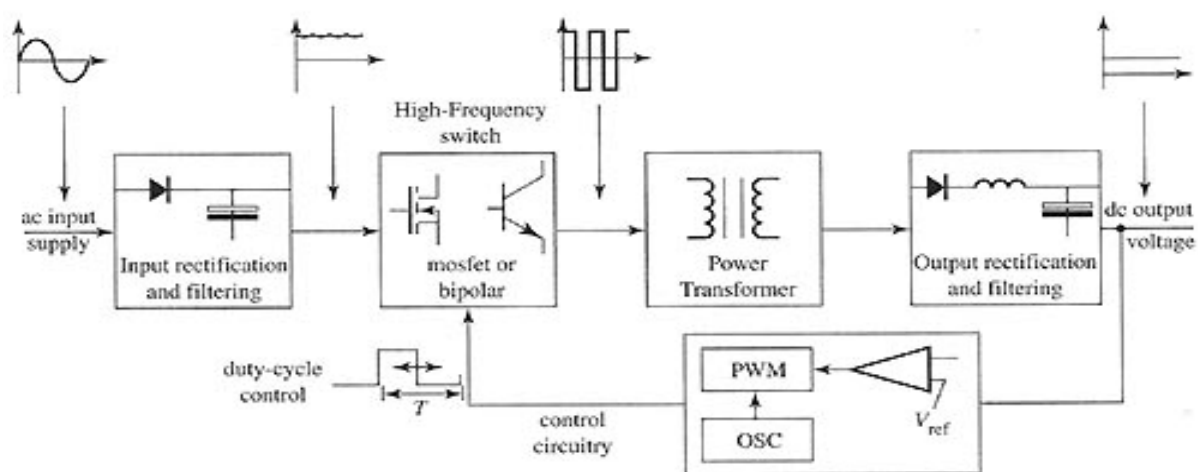

Fig. 1. Block diagram of a switch-mode power supply (SMPS)

The next section of the SMPS is the power transformer section. The power transformer isolates the circuits and steps up or steps down the voltage to the level required by the DC voltage. The output of the transformer is sent to a second rectifier section. The output rectification section is different from the input rectifier. The frequency of the voltage in the second section will be very high.

The final section of the SMPS is the control and feedback block, which contains circuitry that provides pulse-width modulated output signal. The pulse-width modulation provides a duty cycle that can vary pulse by pulse to provide an accurate dc output voltage. [3]

Summarizing the results of the analysis, we can conclude that chargers, based on inverter with an output transformer, have the best performance parameters under the research. Restrictions on weight and dimensions chargers force developers to use semiconductor converters as part of chargers, which reduce the dimensions and weight and increase efficiency.

The study of the work in this area proves that the use of high frequency converters can reduce the dimensions and weight of the charger and also control the charging process precisely.

References

1. But D.A. Energy storage. Moscow: Energy atom publ., 1991. – 400 p.
2. Pentegov E.Yu. Fundamentals of charging circuits capacitive storage. Kiev: Naukovka dumka, 1982. – 406 p.
3. URL: <http://www.industrial-electronics.com>

Scientific Supervisor: U.A. Ulianova, senior lecturer of TPU