

2009

# Social Capital: Relationship Between Social Capital and Teacher Job Satisfaction Within a Learning Organization

Timothy Lee Chazon  
*Gardner-Webb University*

Follow this and additional works at: [http://digitalcommons.gardner-webb.edu/education\\_etd](http://digitalcommons.gardner-webb.edu/education_etd)

 Part of the [Curriculum and Social Inquiry Commons](#), [Educational Assessment, Evaluation, and Research Commons](#), [Educational Methods Commons](#), and the [Educational Psychology Commons](#)

---

## Recommended Citation

Chazon, Timothy Lee, "Social Capital: Relationship Between Social Capital and Teacher Job Satisfaction Within a Learning Organization" (2009). *Education Theses, Dissertations and Projects*. Paper 103.

This Dissertation is brought to you for free and open access by the School of Education at Digital Commons @ Gardner-Webb University. It has been accepted for inclusion in Education Theses, Dissertations and Projects by an authorized administrator of Digital Commons @ Gardner-Webb University. For more information, please contact [digitalcommons@gardner-webb.edu](mailto:digitalcommons@gardner-webb.edu).

Social Capital: Relationship Between Social Capital and Teacher Job Satisfaction

Within a Learning Organization

By

Timothy Lee Chazon

A Dissertation Submitted to the  
Gardner-Webb University School of Education  
in Partial Fulfillment of the Requirements  
for the Degree of Doctor of Education

Gardner-Webb University

2009

© 2009 by Timothy Lee Chazon. All Rights Reserved.

Approval Page

This dissertation was submitted by Timothy Lee Chazon under the direction of the persons listed below. It was submitted to the Gardner-Webb University School of Education and approved in partial fulfillment of the requirements for the degree of Doctor of Education at Gardner-Webb University.

---

David Shellman, Ed.D.  
Dissertation Chair

---

Date

---

Douglas Eury, Ed.D.  
Committee Member

---

Date

---

Nathaniel Felder, Ph.D.  
Committee Member

---

Date

---

Gayle Bolt Price, Ed.D.  
Acting Dean of Graduate School

---

Date



## Acknowledgements

There are three pearls of wisdom found in the Word of God that have found their way into the start and finish of this dissertation. First, many are the plans in a man's heart, but it is the Lord's purpose that shall prevail. Second, in a multitude of council, there is wisdom and safety. Finally, the love of God is greater than our hearts. My original plan for the dissertation certainly evolved over time into something of which I am very proud, and I am certainly thankful to God for His guidance in completing the dissertation. Completing a dissertation required a great deal of trust and openness on my part and also required a great deal of humility. As I sat and talked with men such as Dr. Shellman, Dr. Eury, Dr. Felder, Dr. Bowen, and Dr. Kane, I realized that their individual and combined knowledge is overwhelming. I am sincerely grateful for their time and effort in helping me complete such an exhausting task. There were many dark times, feelings of isolation, loneliness, and desperation, coupled with hours upon hours of reading, writing, and researching. I truly understand now why so many do not complete this task. Only God knows the number of times that I have prayed for strength, courage, and wisdom to see this task to the end. God indeed answers prayers. In doing so, He has given me a new start in life. His plans are far more important than my plans. I may not understand them, but I do have a deeper trust and faith in God. We are His creation, and when we are in doubt and or fear the unknown or the ambiguous, God's love for us will see us through. My wife, friends, and family have always believed in me, and for this reason, it is my honor and privilege to share the prosperity, peace, and wisdom that comes with having a Doctorate in Educational Leadership.

## Abstract

Social Capital: Relationship Between Social Capital and Teacher Job Satisfaction Within a Learning Organization. Chazon, Timothy Lee, 2009: Dissertation, Gardner-Webb University, Social Capital/Learning Organization/Cognitive/Structural Relationship/Job Satisfaction/ Potential Performance/Actual Performance/ Collaboration/Networking

This dissertation was designed to study the relationship between Social Capital and teacher Job Satisfaction for 11 selected North Carolina Middle Schools. This study uses the learning organizational theory and social capital theory as theoretical constructs for studying the complex relationships between school as a Learning Organization (LO), Social Capital (SC), and teacher Job Satisfaction (JS). SC encompasses the interactive-interpersonal relationships and the values that are placed on those relationships whose collaborative efforts provide collective leverage to obtain an agreed-upon task. SC, according to Subramaniam and Youndt (2005), is intrinsically tied to Human Capital (HC), which is the individual knowledge, skills, experience, and/or expertise an individual utilizes within the organizational framework. Teachers, school administrators, and school support staff possess individual knowledge and skill for the positions for which they were hired. The researcher used the SC constructs to form a conceptual bridge between the LO concept and JS among teachers. As a first step in examining the validity of this model, the researcher used Confirmatory Factor Analysis (CFA) to examine the fit between Bowen's 12 LO dimensions and their theorized manifest indicators, as operationalized in Bowen's Student Success Profile-Learning Organization (Bowen, Rose, & Ware, 2006).

This analysis yielded the conclusion that an acceptable degree of fit existed between the observed and theorized relationships between the LO dimensions and their manifest indicators. The researcher then used CFA to examine the theorized versus observed relationships between the scored LO dimensions (justified on the basis of the initial CFA) and the 3 SC constructs. Upon confirming that an acceptable degree of fit existed between the theorized and observed LO-SC relationships, the researcher proceeded to determine the degree to which the 3 SC constructs accounted for the variance in teacher JS using ordinary least squares multiple regression. This resulted in the finding that 2 of the 3 SC constructs (viz., Cognitive Social Capital and Relational Social Capital) accounted for significant portions of the variance in teacher JS, combining to account for 10.8% of JS variance.

## Table of Contents

	Page
Chapter 1: Introduction.....	1
Introduction.....	1
Schools as Learning Organizations.....	2
Merger of Theoretical Concepts: Learning Organization and Social Capital.....	4
Problem Statement.....	5
Purpose of Study.....	7
Collective Collaboration of the School as a Learning Organization.....	8
Significance of the Study.....	11
Research Questions.....	12
Definition of Terms.....	13
Theoretical Background.....	17
Setting for the Dissertation Study.....	19
Summary of Chapter 1.....	19
Chapter 2: Literature Research.....	20
Historical View of Social Capital.....	20
Social Capital: Post Modern.....	22
Learning Organization.....	23
Learning Organization and Its Link to Social Capital.....	24
Social Capital: Practical Application.....	25
Job Satisfaction Within the Framework of a School as an Organization.....	30
Job Satisfaction: A Historical View.....	34
Recent Public School Developments.....	40
Student Teachability: Insight to Students Learning Before Arriving at School.....	43
North Carolina Teacher Working Conditions.....	49
Relationships Examined in the Study.....	51
Schools as Learning Organizations.....	55
Summary of Chapter 2.....	57
Chapter 3: Methodology.....	58
Introduction.....	58
Study Design.....	60
Structural Equation Measurement Model and Structural Model.....	61
Ordinary Least Squares: Regression Model.....	62
Support for the Conceptual Linkages.....	63
School Success Profile-Learning Organization: Instrument Reliability.....	65
Instrument Validity.....	65
Sampling.....	66
Source of Data.....	68
Data Analysis.....	68
Research Questions.....	69
Limitations of the Study.....	70
Principal Leadership.....	71
School Leadership Team.....	72
Intellectual Capital.....	73

Human Capital .....	73
Delimitations.....	74
Chapter 4: Analysis of Data.....	77
Introduction.....	77
Descriptive Statistics .....	77
First Phase of the Statistical Analysis .....	80
Second Phase of the Statistical Analysis .....	85
Third Phase of the Statistical Analysis .....	90
Fourth Phase of the Statistical Analysis .....	91
Fifth Phase of the Statistical Analysis .....	92
First Phase Results: Exploratory Factory Analysis .....	95
Second Phase Results: Confirmatory Factory Analysis .....	96
Third Phase Results: Research Question 2 .....	96
Fourth Phase Results: Research Question 3 .....	97
Fifth Phase Results: Confirming the Observed Covariance Matrix and the Covariance Matrix .....	98
Chapter 5: Dissertation Summary and Discussions .....	99
Introduction .....	99
Problem Statement.....	99
Summary of Findings.....	101
Examination of Literature Review in Relation to Dissertation Findings.....	102
Limitations of Study .....	103
Theoretical and Practical Implications for Improving the Theoretical Model .....	103
Practical Solutions to Promote the Increase of Social Capital Within Schools.....	105
Conclusion: Implications for Future Research .....	109
References.....	111
Appendixes	
A Permission to use SSP-LO Data from 11 Middle Schools in NC.....	115
B School Success Profile-Learning Organization (SSP-LO) .....	117
C School Success Profile-Learning Organization Dimensions .....	123
Tables	
1 School Participants.....	18
2 Frequency Distributions of Sample on Relevant Demographic-Occupational Variables .....	67
3 Respondents' Years of Experience at Their Current School .....	78
4 Social Capital Constructs.....	78
5 Respondents' Intention to Continue Employment as a Discrete Variable.....	79
6 Descriptive Statistics for 12 Learning Organization Dimensions.....	80
7 Results of First CFA Analysis for the 12 Learning Organization Dimensions .....	82
8 Regression Weights for SEM model.....	88
9 Results of SEM Analysis Linking the 12 LO Dimensions with the 3 SC Constructs .....	89
10 Correlations Among the Three SC Constructs.....	90
11 Results of Regression of Job Satisfaction on the Three Social Capital Variables.....	92
12 Results of the Analysis of the Full SEM Model .....	94
Figures	
1 Conceptual Model with Proposed Relationships .....	58

2	CFA Model for the 12 Learning Organization Dimensions .....	84
3	First SEM Model Without Relational Data (Regression Weights).....	86
4	SEM Model With Relational Data (Regression Weights) .....	87
5	Complete Structural Equation Model .....	93

## Chapter 1: Introduction

### *Introduction*

In today's twenty-first century schools, intellectual excellences are better known as knowledge, skills, and understanding (Hargreaves, 2001). Hargreaves stated, "The purpose of education is to initiate the young into these excellences through which they acquire the disposition to make sound intellectual and moral *judgments* and choices thereby becoming productive citizens" (p. 488).

Schools exist to educate students and aid them in discovering their academic potential, with an emphasis on developing and building morally responsible, intellectually capable, and thoughtfully civil contributors to society (Hamilton, 2007; Hargreaves, 2001). Public schools are presently viewed and evaluated by student outcomes. The No Child Left Behind Act (NCLB) 2001, a federal mandate made into law, currently holds states accountable for high student achievement and requires states to "establish proficiency levels in math, reading/language arts and ultimately in science (*launched in 2007*) and further requires 100% of students to meet or exceed these proficiency levels by 2014" (NSBA, 2004, introduction). In addition, the State Board of Education for North Carolina holds local educational agencies accountable for those achievements through the North Carolina ABC's accountability model as stated in the NC School Report Cards (2007, p. 1). North Carolina Schools are expected to increase student achievement and the progress is reported as the school's Adequately Yearly Progress (NC School Report Cards, 2005-2006, p. 4).

Hargreaves (2001) explained that student outcomes are either cognitive or moral achievements and cited Aristotle who stated that the purpose or responsibility of states or

institutions is to assist their citizens to lead productive lives. Hamilton (2007) cited an American founding father, John Locke, who wrote that governments are instituted to assist in securing “people’s right to life, liberty, and property” (p. 1). The United States’ Declaration of Independence states each citizen has a right to life and the pursuit of happiness. The Greek word for happiness is *eudemonia* and when translated to English means happiness or well-being (Hamilton; Hargreaves). Well-being, according to Hargreaves, is a quality of life or a way to conduct one’s life. The implied deduction is that happiness for a citizen is the pursuit of virtuous activity. Aristotle considered virtue as excellence (Hargreaves). According to Aristotle, there are two kinds of excellences, intellectual excellences such as art, science, and history and moral excellences such as integrity, courage, and justice (Hargreaves).

#### *Schools as Learning Organizations*

Schools are, therefore, *Learning Organizations* (LO) responsible for providing educational opportunities for students to discover problems, engage in solutions, and develop the capacity to think, reflect, and problem solve in order to lead a productive life through intellectual and moral excellences. According to Kezar (2005), a learning organization is “an environment that promotes a culture of learning, a community of learners, and ensures that individual learning enriches and enhances the organization as a whole” (p. 10).

Gary Bowen, along with his colleagues developed the School Success Profile Learning Organization Inventory, a survey assessment instrument used to capture the dimensions (manifest indicators) of a LO. Bowen, Rose, and Ware (2006) defined LO concept as a “core set of conditions and processes that support the ability of an

organization to value, acquire, and use information and tacit knowledge acquired from employees and stakeholders to successfully plan, implement, and evaluate strategies to achieve performance goals” (pp. 98-99).

Using a deductive approach based on the literature provided by Hargreaves (2001) and Bowen and Bowen (1999), the on-going dichotomy of public school practitioners is to evaluate the intellectual and moral excellences of the students and match those identified needs with the instructional strengths of the teaching staff. Teachers are therefore, responsible agents for assessing and evaluating student’s academic needs, analyzing achievement data and delivering instruction while simultaneously working within the parameters of the LO.

The teacher’s role in the LO is crucial to the organizational development and stability needed to create an environment conducive to teaching and learning. Also, the school’s organizational ability to create a learning environment requires the school as a LO to effectively communicate as a staff, analyze school data, and transfer information to tacit knowledge to ascertain academic outcomes.

Hargreaves (2001) referred to this exchange as important, with the cultural aspect of social capital being in part “trust between people and the generation of norms of reciprocity (mutual favours) and collaboration” (p. 490). Thus, teachers are well aware of the LO’s potential to achieve derived year-long goals or outcomes and are also cognitively aware of the school’s actual performance as it relates to standardized yearly testing results. The school’s potential performance and actual school performance are intrinsically tied to the collaborative and concerted effort of the administrative staff, support staff, school leadership team, and teaching staff.



Thus, it is the responsibility of all school staff members to educate children; therefore, the expectation is to work collaboratively as a team of professionals within a LO to ensure students are equipped and taught to pursue both intellectual and moral excellences.

These ideas are supported by Leana and Pil (2006) who stated that “schools are increasingly enacting collective mechanisms to enhance *student* performance” and promote the idea of [*sic*] “student performance as a collective effort across the school rather than as a solo endeavor by individual teachers within the school” (p. 355). This is the endeavor of a LO to collectively address organizational processes to ensure the school culture is conducive to maintaining a positive learning environment. Bowen et al. (2006) cited Hiatt-Michael who stated “the learning community is an organization in which all members acquire new ideas and accept responsibility for developing and maintaining the organization” (p. 200).

#### *Merger of Theoretical Concepts: Learning Organization and Social Capital*

Using the research of Bowen et al. (2006), the researcher examined 11 North Carolina Middle Schools through the lens of Social Capital (SC). By employing Bowen’s LO theoretical concepts and the SC theoretical concepts, the researcher examined the relationship between SC and teacher job satisfaction (JS) using a new theoretical model. Bringing literature findings into play, the researcher used the following as an operational definition for SC: the interactive-interpersonal relationships and the values placed on those relationships and whose networking (*collective sharing*) that provides leverage to obtain a collective, agreed-upon task (Adler & Kwon, 2002; Leana & Van Burren, 1999; Nahapiet & Ghoshal, 1998).

Researchers, Nahapiet and Ghoshal were cited by Leana and Pil (2006) as the researchers who conceptualized the idea of formalizing the three constructs of SC. The three SC constructs consist of a) structural construct, b) relational construct, and c) cognitive construct. The structural construct of SC accounts for the quality of decisions shared by teachers, which over time either strengthens the increasing density of the relationship, or weakens it. The relational construct of SC is the trust and trustworthiness developed between and among teachers. The cognitive construct of SC is the shared vision among teachers (Leana & Pil).

Therefore, SC at the organizational level provides leverage (assets available through established and well-connected network relationships) that supports, improves, and at times, changes the infrastructure of the organization to effectively reach and maintain its desired goals (Hargreaves, 2001; Subramaniam & Youndt, 2005). Using Bowen and Powers (2003) School Success Profile-Learning Organization (SSP-LO), the researcher establishes a connection with the 12 LO dimensions to the 3 SC constructs in efforts to examine the relationship between SC and teacher self-reported JS within a LO.

### *Problem Statement*

Hargreaves (2001) suggest that school environments characterized by coworker relationships that lack trust, respect, and cohesion are likely to have adverse consequences for the work performance of teachers working in such environments. Violations of the norms and values of working relationships have negative impacts on the LO. This study views these aspects of the LO using one of three theoretical constructs of SC. Trust, respect, and cohesion among teachers is observed and measured using the Relational Social Capital (RelSC) construct derived by the new theoretical model.

Another problem associated with violation of norms and values is the limitation or reduction of the quality of information flow and knowledge shared among teachers. Information flow is one of the factors associated with the second SC construct of the derived theoretical model. Structural Social Capital (StrSC) is directly associated with how information and knowledge is transferred among its members. Negative working relationships can adversely influence the school's organizational decision-making ability to achieve selected goals/outcomes and thereby can disrupt the cohesion and collective agreement needed to accomplish the shared vision for the school. Negative working relationships within a LO have negative consequences, which present distractions from what is important, disrupt information flow, and diminish the organization's ability to achieve its mission. For the purpose of the study, the RelSC construct consisted of four factors: respect, cohesion, trust, and mutual support, which teachers experience through their interactions with their coworkers. Information flow is one of the factors associated with the second SC construct, Structural Social Capital (StrSC), and is directly associated with how information and knowledge is transferred among its members and is associated with administrators as an important factor in JS. The third SC construct of the theoretical model is Cognitive Social Capital (CogSC). CogSC is associated with teacher feelings and actions, which can be observed through the degree of optimism with which tasks are approached and the common purpose that propels teachers to achieve their selected goals.

Thus, the National Center of Education Statistics (1997) reported "that when teachers perceive a lack of support for their work, they are not motivated to do their best in the classroom, and that when teachers are not satisfied with their working conditions; they are more likely to change schools or leave the profession" (p. 3).

Researchers Toremén and Karakus (2007) studied obstacles that decrease synergy in schools. The Toremén and Karakus study revealed that schools could achieve more if they worked collectively, focused on open communication among teachers, held stronger collegial norms that were accepted by the school culture, worked in teams that were without structured inequalities, were inclined to work together collectively, and behaved “empathically and altruistically” (p. 642). The work of Bowen and Powers (2003), Hargreaves (2001), Toremén and Karakus, and others share the conception of a LO as being composed of individuals in a social setting who are responsible for achieving various organizational outcomes. However, the lack of SC within the LO limits, restricts, and diminishes the organization’s ability to reach the goals/outcomes to which it aspires.

#### *Purpose of Study*

The purpose of this study was two-fold. First, the researcher wanted to show the relationship between SC and teacher JS as viewed through the school as a LO. Second, the researcher planned to examine and determine whether the theoretical model proposed could be supported by enough literature and sufficient empirical evidence to support its conceptual framework. The schools selected for the study are 11 middle schools located in southeastern urban and rural areas of North Carolina. The data were collected in a 2004-2005 research study designed by Gary Bowen, a professor at North Carolina at the University of North Carolina at Chapel Hill (Bowen and Powers, 2003). For the purpose of this study, student achievement, student readiness, LO’s potential and actual performance are mentioned as an intervening variables, however, not a quantifiable variable of the study.

*Collective Collaboration of the School as a Learning Organization*

Each year educational practitioners such as school administrators, teachers, and school support services (counselors and social workers) face difficult challenges with analyzing student data to determine what educational opportunities, instructional programs, and support services are essential to address the academic (intellectual) and social behaviors of students. Leana and Pil (2006) state No Child Left Behind Act (2002) placed mandates on schools, not individual teachers. However, the collaborative efforts of teachers are vital to the organizational success and overall performance of the school (Toremén & Karakus, 2007).

Each new school year, teachers are either executively placed or volunteer to work together with other teachers, school administrators, and school support staff. The executive placement is to ensure each student receives the best educational opportunities by creating cohesive grade-level teams (Lenna & Pil, 2006). Lenna and Pil (2006) referred to this type of executive placement as a mechanism to increase student performance. Leana and Pil cited Bryk and Schneider, 2002; McLaughlin and Talbert, 2001; and Smylie and Hart, 1999; stating these mechanisms also include “team-based professional development, common planning time for teachers, cross-grade teams, and collective accountability measures” (p. 355). Additional support services can also provide the necessary resources to assist in the education of students. It is also pertinent to mention at this point that researchers say an important element in the education of a student is the amount of preparation the student brings with them when entering each school year (Greene & Forster, 2004). The Student Readiness Index measures how much academic preparation and support students receive before entering the school doors and

how much education takes place after school (Greene & Forster). For the purpose of the study, Student Readiness (SR) is not a quantifiable variable for this study and was observed as an intervening variable.

The researcher includes substantial literature that supports the belief that SR is an intervening variable for the study and may attribute to teachers job dissatisfaction within the LO. Additionally, Title I schools serve students whose social factors often impact educational output such as student achievement. Thus, the school's organizational potential and actual school performance may or may not attribute to teacher satisfaction and/or dissatisfaction, however students are the educational institutions' primary customers and it is important to understand the dynamics of the students' families and communities.

According to Bowen and Bowen (1999) and Edgar Schein (1985), social systems have two primary goals that are interrelated and highly interdependent of each other: external adaptation (How will the school adjust or assimilate to the community it serves?) and internal integration, or the internal integrity of the school's functioning system. Bowen and Bowen also stated, "A school that is without internal bonds of commitment, supportive cohesion, and a sense of caring and support is unlikely to achieve its mission" (p. 62). In contrast, viewing the LO through the lens of SC provides further insight to the quality or strength of direct and indirect relationships among teachers and school administrators. Such an examination suggests SC in a LO is a contributing factor to teacher JS. The quality and strength of teacher relationships within a LO was one of the primary focuses of this dissertation. The social interaction of teachers within the LO was observed through the three SC constructs: relational, structural, and cognitive and their

relation to teacher JS.

In 2008, North Carolina Governor Mike Easley announced findings regarding the 2008 Teacher Working Conditions Survey. In the announcement, schools with strong, supportive leadership and sufficient school resources resulted in students performing at higher levels. Also, the report found that teachers who indicate they would like to remain at their schools are three times more likely to report their School Improvement Team is effective and twice as likely to report that teachers participate in the school improvement planning process. The largest difference between high turnover and low turnover schools is attributed to “the effectiveness of the School Improvement Team, the presence of atmosphere of trust and mutual respect, and the ability of the leadership to shield teachers from disruption” (Easley, 2008, p. 5). Based on the findings, it is essential for each school staff to prepare a suitable educational environment that is conducive to the learning needs of the students as well as a suitable work environment. This is clearly established through teacher collaboration among colleagues. Also, it is the School Leadership Team (SLT) that acts as a collective agent for directing the schools’ mission, creating a conducive work environment, and creating a positive student learning environment. The SLT is also responsible for developing the school’s educational plan, or School Improvement Plan, which outlines the school’s educational plan to address the academic needs of students’. For the purpose of the dissertation, the SLT is a key component to ensure that each school’s vision and strategic plan addresses students’ academic needs and is shared with teachers, parents, and community stakeholders. For the purpose of the dissertation, the SLT is an intervening variable, noting that each school uses its SLT for many purposes and no two schools use the SLT in the same way.

Teachers are expected to carry out the educational plan. How well teachers communicate and collaborate within the social fabric of the school among their peers was a concern of the researcher. Bowen, Ware, Rose, and Powers (2007) used the term collective synergy to describe how school staff needs to respond as an organization in an effort to effectively communicate, share knowledge, and work toward a perceived goal or accomplish a set task. A school's ability to share, exchange, and transfer knowledge is contingent upon the mutual respect and trust among the school staff. Leana and Pil (2006) cited Leana and Van Buren, stating the collective action of a group as a "phenomenon 'associability' or the willingness and ability to define collective goals that are then enacted collectively" (p. 354). A school's organizational strength relies heavily on the stability and solidarity of teachers' work relationships and their ability to transfer information to achieve academic outcomes. Also, the collective unity of the staff assists the school's leadership team by informing community stakeholders, designing and planning the best educational opportunities for students, and creating and developing an enriched work environment for teachers.

### *Significance of the Study*

The researcher believes the study will add to existing literature as well as provide a theoretical framework for future studies. Using existing data, the researcher has designed a new measurement model linking the Bowen et al. (2007) theory of a LO to the theoretical concept of SC constructs proposed by Nahapiet and Ghoshal (1998). This study showed the relationship of SC to teacher JS and, for future studies, created a framework to explore and possibly predict LO outcomes such as teacher JS, student achievement, and teacher attrition. Over the last decade, scholars and researchers have



explored and theorized the theoretical concepts of learning organizations, social capital, intellectual capital, and human capital and they are discovering the intricacies of each concept and their inter-relationship with one to another. This researcher sees this type of study as a continuous piece of work that offers schools an instrument that provides suggestions and/or solutions to help improve a school's preparation for incoming students, to increase teacher effectiveness, and to create a working atmosphere that generates a positive and enriching learning environment for students.

### *Research Questions*

*First Research Question. R<sub>1</sub>:* What relationship exists between the 12 LO dimensions (manifest indicators) and the three latent variables; Structural Social Capital (StrSC), Relational Social Capital (RelSC), and Cognitive Social Capital (CogSC)? StrSC consists of four actions: Team orientation, Stakeholder Involvement, Information Flow, and Results, which make up the four manifest indicators. RelSC consists of four sentiments: Respect, Cohesion, Trust, and Mutual Support which make up the four manifest indicators. CogSC consists of two actions and two sentiments: (a) Tolerance for Error and Innovation (actions), (b) Common Purpose and Optimism (sentiments). It should be noted that the conceptual definition of each of the SC constructs will be operationally measured by the four manifest indicators assigned to each construct.

*Second Research Question. R<sub>2</sub>:* What relationship exists among StrSC, RelSC, and CogSC?

*Third Research Question. R<sub>3</sub>:* How much variation in teachers self-report of job satisfaction can be attributed to the influence of StrSC, RelSC, and CogSC?

*Fourth Research Question. R<sub>4</sub>*: Will there be at least a minimally acceptable degree of fit between the observed covariance matrix and the covariance matrix produced by the conceptual model?

The research questions were designed to examine what the researcher predicted will be a positive relationship between SC and the level of teacher self-reported job satisfaction at 11 selected North Carolina southeastern urban and rural middle schools.

#### *Definition of Terms*

*Learning Organization (LO)* is a “core set of conditions and processes that support the ability of an organization to value, acquire, and use information and tacit knowledge acquired from employees and stakeholders to successfully plan, implement, and evaluate strategies to achieve performance goals” (Bowen et al., 2006, pp. 98-99).

*Social Capital (SC)* is the interactive-interpersonal relationships and the values placed on those relationships whose networking provides leveraging to obtain a collective, agreed-upon task within and beyond the parameters of the school.

*Job Satisfaction (JS)* is the individual’s perception and personal examination of their work environment.

*Human Capital (HC)* is the body of knowledge and experiences each person brings to the organization.

*Learning Organization Actual Performance of a School* is evaluated by how students perform on the state norm end-of-grade and end-of-course tests and how the school as a whole performed in relation to the North Carolina ABC’s Accountability Model and Adequate Yearly Progress report. The North Carolina Annual Report indicates the school’s annual performance.

*Learning Organization's Potential Performance of a School* is the collective and agreed-upon School Improvement Plan, its components (target goals), its solutions (interventions), its evaluations, and the results of its overall accomplishments.

*School Improvement Plan* is a collective agreement between the teachers of the school, school administration, and district support staff on agreed-upon target goals directed towards improving student achievement.

*Student Achievement/Student Proficiency* are terms used to refer to student work that meets academic achievement levels or standards set by North Carolina. Students who are proficient are performing at or above grade level and usually meet the demands of the next grade level.

*School Performance based North Carolina's ABC's Accountability Model* is a comprehensive plan to improve public schools. The accountability model is based on three goals: strong accountability, major emphasis on student mastery of basic skills, and as much local control as possible for Local Educational Agencies (NC School Report Cards, 2007, p. 1). Each North Carolina school receives a designation based on its performance on the state's standardized tests. The following are school designations based on the percentage of students performing at grade level, and/or whether or not they meet their growth standards.

*Honor School of Excellence:* At least 90% of the students' scores are at or above achievement Level III and the school makes or exceeds its expected growth goal. Additionally, the school has achieved Adequate Yearly Progress (AYP).

*School of Excellence:* At least 90% of their student's scores are at or above achievement Level III and the school makes or exceeds its expected growth goal.

*School of Distinction:* 80-89% of students' scores are at or above achievement Level III and school makes or exceeds its expected growth goal.

*School of Progress:* 60-79% of students' scores are at or above achievement Level III and school makes or exceeds its expected growth goal.

*School Receiving No Recognition:* School fails to reach its expected growth goals, but has at least 60% of its student performing at or above achievement Level III.

*Priority School:* School has less than 60% of its students' scores at or above achievement Level III and is not identified as a Low-Performing School.

*Low-Performing School:* School fails to reach its expected growth goal and has significantly less than 50% of its students performing at or above achievement Level III.

*High Growth:* A K-8 school achieving approximately 10% of its expected growth goal or a 9-12 school achieving approximately 3% above its expected growth goal in selected courses.

*Expected Growth:* School made its expected growth goal for the school year.

*Annual Measurable Objectives (AMOs)* for grades 3-8 for the 2005-2006 through the 2006-2007 school years; the AMO targets are 76.7% proficiency in reading/language arts, and 65.8% in mathematics (NC School Report Cards, 2005-2006, pp. 3-4).

*Adequate Yearly Progress (AYP)* for each sub-group represented in a school; the school must make progress toward achieving performance standards in both reading and mathematics. The groups represented are: a) The school as a whole, b) Black, c) White, d) Native American, e) Asian, f) Multiracial, g) economically disadvantaged, h) Limited English Proficient Students, and i) students with disabilities. A sub-group must have 40 or more students represented in a category in order to count toward AYP (NC School

Report Cards, 2005-2006, p. 4). Middle Schools must meet the following criteria in order to achieve Adequate Yearly Progress:

1. 95% participation rate in reading/language arts assessment.
2. 95% participation rate in mathematics assessment.
3. Meet or exceed the state's Annual Measurable Objective (AMO) for proficiency in reading/language arts.
4. Meet or exceed the state's annual measurable objective (AMO) for proficiency in mathematics.

The school as a whole must show progress on the Other Academic Indicator (OAI) attendance for schools and on-time graduation rates (NC School Report Cards, 2005-2006, p. 4).

*Level I:* Students who perform at this level do not have mastery of knowledge and skills in their grade level, nor are these students successful at the next grade level and have more difficulty with more advanced material at their present grade level.

*Level II:* Students performing at this level are inconsistent with mastery of the knowledge and skills required for their present grade level, are minimally prepared for the next grade level, and have difficulty with more advance material at their present grade level.

*Level III:* Students performing at this level consistently demonstrate mastery of the knowledge and skills in their grade level, are prepared for the next grade level (EOG), and are prepared for more advanced material in the subject area (EOC).

*Level IV:* Students performing at this level perform consistently, clearly demonstrate mastery of the knowledge and skills required for the course, and are better

prepared for the next grade level and are clearly more advanced to achieve or perform at the next grade level (NC School Report Cards, 2005-2006, p.1).

### *Theoretical Background*

This study focuses on organizational and social capital theories as theoretical construct for exploring the link between a LO and SC and discovering the relationships between SC and JS as perceived by teachers. A LO, according to Bowen et al. (2007) is a “core set of conditions and processes” of an organization (p. 200). Schools are organizations, and the persons within the organization have a school culture with certain values and norms that can be observed through actions and sentiments that can be viewed through a different lens using the theoretical concept of SC. SC is the interactive-interpersonal relationships and the values that are placed on those relationships whose collaborative efforts provide leverage (power to access opportunities collectively and not necessarily available by one’s own individual ability or volition) to obtain a collective, agreed-upon task.

SC, according to Subramaniam and Youndt (2005), is intrinsically tied to *Human Capital* (HC) which is the individual knowledge, skills, experience, and/or expertise an individual utilizes within the organizational framework. Teachers, school administrators, and school support staff possess individual knowledge and skill for the positions for which they were hired. A body of research supports and recognizes that individuals possess a body of knowledge with skills and talents; however, those skills, when applied to a group or team, create potentially more innovative capabilities than in isolation. HC, therefore, is the body of knowledge and the experiences each person brings to the organization. SC, hence, is the collective, interactive-interpersonal relationships of

humans. The experiences and knowledge each person brings to the collective group empowers the group to accomplish tasks or goals that would not be attainable through individual means. Regarding SC, Lee (2005) cited Cohen and Prusak (2001) stating “the stock of active connections among people: the trust, mutual understanding and shared values and behaviours that bind the members of human networks and communities and make co-operative action possible,” thus not otherwise obtained through individualized talents/skills (p. 3). Table 1 reports the number of participants for the study.

Table 1

*School Participants*

School ID Number	School Name	N
1	MS I	65
2	MS II	59
3	MS III	51
4	MS IV	52
5	MS V	93
6	MS VI	75
7	MS VII	57
8	MS VIII	69
9	MS IX	95
10	MS X	66
11	MS XI	79
<b>Total Participants</b>		<b>761</b>

*Note:* MS = middle school; N = number of participants.

The result for Table 1 includes a total number of 761 participants, ranging from a low of 51 in one school to a high of 95 in another across 11 middle schools located in the southeastern part of North Carolina.

### *Setting for the Dissertation Study*

The researcher's position in one of the school districts used for the study was neutral with no direct position of influence other than employment at the time of the study. The 11 middle schools selected for the study are located in the southeastern rural and urban areas of North Carolina.

### *Summary of Chapter 1*

The emphasis of the study was to examine 11 North Carolina public middle schools using a new theoretical model which combined two theories, Learning Organizational theory and Social Capital theory. Specifically, the study examined the perspective of teachers within their selected schools to discover what contribution or influence Social Capital has on teachers' self-report of JS. Thus, a new theoretical model was proposed to examine the perceptions of teachers within a LO by using three SC constructs: StrSC, RelSC, and CogSC which consist of Bowen's LO manifest indicators. The examination of the relationship between teacher self-reported JS and three SC constructs provides future researchers with theoretical and empirical foundations needed to increase the level of SC within a LO.



## Chapter 2: Literature Research

### *Historical View of Social Capital*

Social Capital (SC) historically has its origins in social communal ties. The integration of the various facets of family structures and interactions, community stability, environmental influences, and religious participation provides researchers with several various theoretical constructs of SC. Ferguson (2006) completed a comprehensive review of the SC literature. The following is a brief review of the concept cited by Ferguson. The basic family social make-up involves intimate and relational interactions among the family members. The “relations between parents and their children, and the time and effort spent by parents with their children” according to Coleman and Hoffer decreased “the children’s likelihood of dropping out of school” (Ferguson, p. 4). Furstenberg and Hughes, as cited in Ferguson, defined SC by two domains: family SC and the outcome of those relationships between parents and children and the community.

Ferguson says that SC can be the result of family embeddings in social interactions and is beneficial. Also, “the higher levels of social interactions between parents and children, in fact, [sic] lowered the likelihood that children faced negatively in future outcomes” (Ferguson, 2006, p. 4). Within the social relationships of families, according to Biosjoly, Duncan, and Hofferth, SC is “potential access to gifts and loans of money or time assistance from non-household members in an emergency” (Ferguson, p.11). This idea of accessing resources outside the family suggests that families have needs outside the basic family structure, which requires social interaction with non-family members usually within the realms or immediate ties of the neighborhood or community. This belief is cited in Ferguson as being supported by Runyan, Hunter, and

Socolar who defined SC as the “benefits that accrue from social relationships within communities and families” (p.16). Depending on the condition of neighborhoods, the benefits of a strong and stable community may, according to researchers, increase or decrease an individual’s SC resulting in limited or abundant resources and or benefits that come through close family interactions and strong community or neighborhood civic ties.

If the neighborhood is impoverished, then Gabarino and Sherman suggested each family within the impoverished community is at risk (discussed more in detail later in the dissertation) and therefore, may not be otherwise associated with economically stable and more affluent community (Ferguson, 2006). According to Ferguson’s synthesis of research, it was Johnson who looked at SC through the lens of Family Social Capital, a “youths relationship to family and also the quality of young people’s perceptions of the quality of neighborhoods in which they reside” (Ferguson, p. 13) and Diaz, Drumm, Ramirez, and Oidjarv who supported this idea by defining SC as the “degree of participation in community” (Ferguson, p. 12). It is in this modern era that researchers begin to deduce links from historical, economical, and social statistical information and apply new perspectives of SC, providing room for other theoretical constructs. Ferguson cited Falk and Kilpatrick who defined SC as “the product of social interactions with the potential to contribute to the social, civic, or economic wellbeing of a community of common purpose” (p. 11). Thus, family members are biologically connected by blood ties, physically connected by living conditions, and emotionally connected by social interactions. So, the natural and environmental ties provide researchers with chances to observe various social interactions. Furthermore, the norms and values each individual contributes within family interactions, community interactions, and work interactions

naturally have benefits that arise from those social-interactive relationships.

*Social Capital: Post Modern*

Putman (2000), a respected researcher of 30 plus years on SC, suggested the “connections among individuals, social networks, and norms of reciprocity and trustworthiness that arise from them” are essentially the key elements that allow families to become stronger, and connect to their neighborhood resources, which results in personal and civic benefits that arise from each personal engagement (p.16).

Alejandro Portes (1998) wrote a review of SC beginning with its origins and applications in modern sociology in the *Annual Review of Sociology*. In his research, Portes pointed to Pierre Bourdieu as the modern or contemporary sociologist who defined the concept of social capital as “the aggregate of the actual or potential resources which are linked to possession of a durable relationships of mutual acquaintance or recognition” (p. 3). Portes also reported that an article published “Provisional Notes” and in French called the “Actes de la Recherchen Sciences Sociales” in 1980 by Bourdieu, however the concept of SC, but did not receive recognition due to the work being written in French. Bourdieu’s work was theoretical and well defined according to Portes; Bourdieu focused on how groups worked together and, by virtue of their collective agreement, benefited from the collective interaction. Portes cited Bourdieu who suggested “the profits which accrue from membership in a group are the basis of the solidarity which makes them possible” (p. 4). Portes asserted that Bourdieu’s SC concept consisted of two elements; first, it is the “the social relationship itself that allows individuals to claim access to resources possessed by their associates and second, the amount and quality of those resources” (pp. 3-4).

The theoretical concept of SC according to Bourdieu may have different forms of capital, however economic and cultural capitals are the primary forms. Economic resources can be observed through bank savings, investments, loans, and other protected economic markets allowing the participants or actors access through social groups that otherwise may not be available. The access to capital gains found in more affluent groups increases the participants' cultural capital as the participants continue contact through their collective relationships, creating greater institutionalized cultural capital. Thus, Portes attributes Bourdieu with modernizing the theoretical concept of SC, further suggesting that the acquisition of SC requires a deliberate investment on the part of the participants in both economic and cultural resources enacting what is commonly known as the universal law of reciprocity-what you do for others will also occur for you.

#### *Learning Organization*

According to Kezar (2005), a Learning Organization (LO) is “an environment that promotes a culture of learning, a community of learners, and ensures that individual learning enriches and enhances the organization as a whole” (p. 10). Gary Bowen, Professor at the University of North Carolina at Chapel Hill, along with his colleagues, developed the School Success Profile Learning Organization Inventory, an assessment tool used to capture the dimensions (manifest indicators) of a LO. Bowen et al. (2007) defined LO, as a “core set of conditions and processes that support the ability of an organization to value, acquire, and use information and tacit knowledge acquired from employees and stakeholders to successfully plan, implement, and evaluate strategies to achieve performance goals” ( p. 6).

### *Learning Organization and Its Link to Social Capital*

Cors (2003) cited Peter Senge (1990), a systems thinker and author of the book, *The Fifth Discipline*, as contributing to the LO concept. In his description of a LO, Senge purposed five disciplines to better understand the conceptual framework of a LO.

In order for the LO to be effective, Senge proposed:

that people first, set aside their old ways of thinking (mental models); secondly, use their individual interpersonal and intrapersonal skills to interact and learn from one another (personal mastery); thirdly, develop a better sense of how the organization works (systems thinking); fourth, form a plan everyone agrees upon (shared vision); and then finally, work to accomplish the organizations vision (team learning) (p. 4).

Senge's five disciplines are in theory similar to the three Social Capital (SC) constructs: a) structural construct, b) relational construct, and c) cognitive construct. The structural facet of SC accounts for the quality of decisions shared by teachers which accounts for Senge's team learning. The relational facet of SC, trust and trustworthiness, is developed between and among teachers' accounts for Senge's personal mastery. Also, the cognitive facet of SC, a shared vision among teachers, is conceptually associated with Senge's shared vision for a LO.

Leana and Pil (2006) examined SC and its relationship with performance at the organizational level of a school. In the summation of their research, Leana and Pil stated that both internal and external SC positively affects the organizational performance of a school. Internal SC, according to Leana and Pil, is composed of three facets: structural (connections among actors), relationship ("describes the kind of personal relationships

people have developed with each other through a history of interactions,”) and cognitive (the interactions of persons as part a collective that allows for development of common goals and a shared vision) (p. 354). For the purpose of delimiting the study, this research focuses on what Leana and Pil refer to as *internal SC* of the LO and what relationships exists between the operational definition of SC and teachers’ reported JS at selected North Carolina Middle Schools.

### *Social Capital: Practical Application*

The operational definition for Social Capital (SC) is the interactive-interpersonal relationships and the values placed on those relationships whose networking (collective sharing) provides leveraging to obtain a collective, agreed-upon task (Adler & Kwon, 2002; Leana & Van Burren, 1999; Nahapiet & Ghoshal, 1998). In addition, SC at the organizational level provides leverage that supports, improves, and at times, changes the infrastructure of the organization. According to Nahapiet and Ghoshal, (1998) organizational capabilities to create and share information through existing structural networks (various dimensions of communications from person to person) provide an “organizational advantage” over other kinds of institutions (p. 242).

Therefore, organizations rely on employees to share their knowledge in efforts to improve the efficiency of the organization. In addition, Subramaniam and Youndt (2005) indicated that SC assists organizations in their ability to assimilate to the environmental changes that occur in an organization and accommodate these changes. SC exists in an organization such as a school and has an influence on the internal social interactions and organizational outcomes. The school’s ability to adjust and be flexible to the many political and social shifts of the community is vital to a school’s organizational success.

Teacher and administrators adjust to state and district-level shifts through their collaborative efforts. In doing so, the staff creates a leveraging system for the organization, which results in high organizational output with a “competitive advantage” (Subramaniam & Youndt, 2005, p. 459).

In other words, social interactions that form strong relational bonds and that result in high levels of trust and cooperation are a valuable resource, and, according to Bowen et al. (2007), create a collective synergy that increases higher educational outputs (Hargreaves, 2001). According to Bourdieu (1986), capital is embedded within the social interactions that are observed through mutual respect and gratitude. In addition, Nahapiet and Ghoshal (1998) defined SC “as the sum of the actual and potential resources embedded within, available through, and derived from the network of relationships possessed by an individual or social unit” (p. 243).

In summary, when individuals in a LO such as a school form strong structural bonds, collectively work together as a team to accomplish their school’s goals, and maintain high levels of mutual trust, the resources embedded in those relationships create more possible opportunities that may otherwise not have been derived through those positive, interactive social relationships. This is central to creating enough SC to establish a working environment in which teachers are satisfied with the organizational structure and the bonds associated within the work groups. When individuals, such as teachers, collectively pool their resources together, with an emphasis on accomplishing a shared task, the result is far superior to individual output.

Hargreaves (2001) stated both concepts of intellectual capital and SC provide a leverage system for the organization system which increases the “conventional concept of

institutional outputs” (p. 489). Hargreaves also states that an effective school is able to mobilize both intellectual capital and SC (trust and sustained networks). The mobilization of intellectual capital and SC is essential in attaining the school’s desired intellectual outcomes and moral excellences. SC according to Hargreaves has two components, cultural (the mutual collaboration and trust between people) and structural (persons who in return operate according to the law of reciprocity and exchange mutual favors.)

In comparison, Kelly (2004) stated, “intellectual capital (*form of social capital*) [sic] brings people and ideas together in deliberate manipulation to create value from the transfer and codification of knowledge” (p. 626). In addition, Armstrong (2002) stated that the contribution of intellectual capital or long-term capital gains by schools, as the combined and collaborative efforts of the School Business Administrator and staff, creates a leverage system for the organization. Further, Armstrong stated a concerted effort is necessary in order to identify, locate, and collaborate with individuals both inside and outside the school building to ensure the success of the organization. This literature supports the idea that schools with substantial SC demonstrate continuous collaborative efforts gathering available resources to address school needs, thereby, increasing the LO’s effort to ascertain successful internal success and measureable school outcomes.

To reiterate, the theoretical purpose of this study was to look in-depth at the working interactions of teachers, through the lens of three constructs of SC. The essential question was: What relationship exists between SC and teachers’ job satisfaction? Researchers Nahapiet and Ghoshal (1998) reported that the structural construct of SC refers to how people or units connect with each other and the patterns that are formed through continuous social interactions. The importance of the structural construct is the



connectiveness between actors that is developed and strengthened over time. The relational construct of SC refers to the trust and/or trustworthiness in a relationship that forms between two or more persons.

Embedded in relationships are assets (Nahapiet & Ghoshal, 1998). Among those assets is the concept of leverage which allows each party in the relationship to benefit from what may not exist with a single person. The old adage proves true; two is better than one. The strength or weakness of the relationship is determined by several factors such as trust, trustworthiness, norms and sanctions, obligations and expectations, identity and identification (Nahapiet & Ghoshal). The third construct of SC is the cognitive dimension. Nahapiet and Ghoshal noted the cognitive dimension relies on how persons in the social group see and analyze things. Nahapiet and Ghoshal cited Cicourel who stated the “cognitive dimension,” refers to those resources providing shared representations, interpretations, and systems of meaning among parties” (p. 244). Madsen (2001), who published the article “Intellectual Capital: Comparison and Contrast,” supports this idea by stating, “one of the most important keys for improving individual and organizational performance is in developing and strengthening intellectual capital (form of social capital) [sic] and exploring the similarities and differences between concepts of intellectual capital, human capital, and knowledge management” (p. 17). In efforts to improve schools, educators would benefit from knowing how the concept of social and human capital, collectively interact to ensure its most important commodity, students, will benefit from the strength of all the variables. Hargreaves (2001) solidified the importance of the study by stating:

Low social capital among teachers entails lack of trust and networking among colleagues, who thus fail to share their pedagogic knowledge and skills, derived from research evidence or personal experience. To neglect the social and moral aspects of school life as a potential distraction from the cognitive and intellectual, threatens the quality of the student's outcomes in the moral excellences. Equally important, failure to recognize that social capital supports the knowledge transfer essential to the maximal mobilization of intellectual capital damages the school's capacity for any kind of improvement. (pp. 492-493)

So, how have educational institutions, particularly urban public middle schools with measurable student success, created enough SC within the organizational infrastructure to sustain years of successful student growth while other schools have failed to show student growth? The researcher acknowledges that locally and nationally, Title I Schools have historically faced significant challenges in educating students from lower soci-economic areas; some have had success while others have struggled to meet federal and state mandates to increase student achievement. Teachers working within the Title I schools, many of which are located in urban areas wrought with high poverty, are faced with stressors that impact the teaching and learning process, teacher moral, teacher turn-over, and teacher job satisfaction.

Gary Bowen (2009) cited Berfalanffy who states:

Schools are a specific type of social system that sociologists label *formal organization*. Unlike informal organizations that are more voluntaristic and typically less organized networks of personal and collective relationships, formal organizations are social systems that have been “plan

fully instituted” to accomplish specific objectives and typically have more rigidly enforced rules and norms that govern social interaction and performance. (p. 61)

The concept of SC captures the collective and collaborative efforts of schools in their efforts to maximize school’s personnel capabilities and increase organizational potential and to improve the overall capabilities of the learning organization, resulting in higher student achievement. Nahapiet and Ghoshal (1998) cited several researchers who believe the following: a) SC increases the efficiency of action among actors, b) SC diminishes the probability of opportunism, c) SC reduces the need for costly monitoring processes, d) SC encourages cooperative behaviors, and e) SC facilitates the development of new forms of associations and organization innovativeness. In addition, researchers, Nahapiet and Ghoshal cited Burt who states that the existence of SC increases the internal interactions of its members, thereby increasing the efficiency among the actors. Nahapiet and Ghoshal cited Putman (1993), Fukuyama (1995), and Jacobs (1965) suggesting that SC reduces the time and energy costs of supervising the existing members of a social unit. Also, SC diminishes actor’s opportunistic behaviors, and encourages cooperative behaviors resulting in what Fukuyama, Jacobs, and Putnam suggest is “central to the understanding of institutional dynamics, innovation, and value creation” (p. 245). The result, improvement of existing organizational elements and a setting that enables members to be creative and more innovative, results in an overall improvement of the organization.

*Job Satisfaction Within the Framework of a School as an Organization*

Pearson and Moomaw (2006) cited Brown and Ferris, stating the three primary,

intrinsic reasons teachers leave the profession include: “a) need for personal growth, b) desire for a philosophy of education, and c) lack of respect and recognition for their efforts” (p. 45). Pearson and Moomaw stated that researchers link teacher autonomy with job satisfaction. Teacher autonomy is defined as a teacher’s freedom to choose or prescribe what, in their perspective, is the best treatment for their students, much like doctors and lawyers. Autonomy is also linked to the teachers’ feelings of whether they themselves are in control and whether or not they control their work environment. In a study completed by the National Center for Educational Statistics (1997), researchers identified that “administrative support, and leadership, student behavior and school atmosphere, and teacher autonomy are working conditions associated with teacher satisfaction; the more favorable the working conditions were, the higher the satisfaction scores were” (p. ix). The National Center of Educational Statistics also reported that when teachers perceive a lack of support for their work, they are not motivated to do their best in the classroom, and that when teachers are not satisfied with their working conditions, they are more likely to change schools or leave the profession.

Pugh and Hickson (1997) referred to Herzberg’s motivational hygiene theory as a valid source for gaining a better perspective for what motivates the average worker. Fredrick Herzberg, referring to job motivation and job dissatisfaction, uses two sets or ranges of human needs to understand what motivates workers. First, there is an animal nature which includes a need for food, warmth, avoidance of pain, safety, and security which is paralleled to job hygiene or maintenance factors. Second, according to Herzberg’s theory, the human or Abraham nature of humans is their need to understand, to achieve, and through achievement, to experience psychological growth. Job hygiene or

animal nature refers to salary, company policy, administration, supervision, interpersonal relationships, and working conditions. Thus, job hygiene is therefore good for an organization, just as personal hygiene is to good health; the lack of it will cause disease or an imbalance of how the body functions, resulting in various psychological, social, and physical ailments. Herzberg's theory suggests that the lack of good hygiene in the work place will cause dissatisfaction, but its presence of itself, cause satisfaction. Herzberg in reference to humans (Abraham nature), stated that, "They have needs to understand, to achieve, and through achievement to experience psychological growth, and these needs are very powerful motivating drives" (Pugh & Hickson, 1997, p. 154). In relation to motivators (Abraham nature), Herzberg said the motivations of teachers are associated with achievement, recognition, advancement, and responsibility, which contribute to job satisfaction if present; however, they are not a factor if not present. Hygiene (animal nature) refers to salary, company policy, administration, supervision, interpersonal relationships, and working conditions, which can lead to job dissatisfaction if not present, however, according to Herzberg, hygiene factors alone do not lead to employee motivation if present. Hygiene factors and job motivation do coexist; however, Herzberg's study found 81% of the contributing factors to job satisfaction were in fact, the motivators (Abraham nature) associated with growth and development (Pugh & Hickson, 1997, pp. 154-155).

Davis and Wilson (2000) completed a study between principal-empowering behaviors and teacher motivation as observed by teachers' report of JS and job stress. Their findings showed a significant relationship between principal empowering behaviors and teacher motivation. The more principals empower their teachers, the greater the

impact teachers feel that they can contribute to fulfilling their work-related tasks and the more likely they will be to believe that their professional choices lead toward more positive outcomes. The report findings support the hypothesis that the more SC increases, the higher the teacher JS rate. Davis and Wilson also stated that teacher motivation is directly but moderately related to JS and job stress. In addition, the report findings of principal-empowering behaviors are important to the organizational social structure but are not related to JS or job stress; however, they are directly related to teachers' perceptions on fulfilling work-related tasks and believing that their choices lead to more positive outcomes. Davis and Wilson's findings of teacher perception of the work environment is in alignment Bowen and Powers (2007) theory of how teachers perceive their school's potential and actual school performance. Davis and Wilson stated that JS is related to intrinsic behaviors such as empowerment and, in addition, "Job satisfaction is the individual's affective relations to their work role and is a function of the perceived relationship between what one wants from one's job and what one perceives it is offering" (Locke, 1969 as cited in Davis and Wilson, p. 350)

In a recent report entitled, *A Report on the North Carolina Teacher Working Conditions Survey* by Hirsch, Emerick, Church, and Fuller (2006), researchers reported the following findings, thus providing additional evidence and insight on teachers' perspectives of their work place within the state of North Carolina. The results of the survey state that 78% of the 60,000 teachers surveyed in North Carolina agreed their school was a good place to work and learn. Also, 87% of teachers surveyed indicated they wanted to "stay" in their school. According to the survey, the following survey questions and teacher responses indicate that the teachers who leave the profession

agreed with the following:

a) There is an atmosphere of trust and mutual respect in this school, 44%; b) the faculty and staff have a shared vision, 49%; c) in this school we take steps to solve problems, 47%; d) opportunities are available for members of the community to contribute actively to this school's success, 66%; e) the School Improvement Team provides effective leadership in this school, 39%; and f) professional development provides teachers with the knowledge and skills most needed to teach effectively, 47%. (Hirsch et al., p. 14)

Thus, based on the above survey results, we can summarize that teachers' perceptions of their work environments are of vital concern and that teachers are intricately involved in many aspects of the school's ability to create, develop, and maintain the school's overall effectiveness through shared knowledge and mutual trust. Also, teachers who leave the teaching profession do so "not just due to dissatisfaction, but other non-teaching related causes" (Hirsh et al., p. 14).

#### *Job Satisfaction: A Historical View*

Clifford Grimes (2006) provided a historical perspective on employee work environments. Grimes looked prior to the 1940's approach to employee motivation through classical management. Employees were evaluated on their personal performance determined by the employees' supervisor of how well a specific task was performed. This classical approach to division of labor was contributed by Fredrick Taylor "viewed the motivations of workers to be profoundly influenced by man's rationale of economic reward, that workers make choices based on the degree of monetary reward or payment systems" (Grimes, p. 15). The need for industrial improvement of industrial technology

produced rapid development of the industry in the United States. The demand for products caused manufactures to produce more rapidly to keep up with consumer use. The later development of the assembly line and the demand for materials due to World War II caused a greater demand of standardization and a division of labor. Grimes also stated that “the introduction of mathematics to business allowed businesses to further project, strategically plan, and make decisions based upon data analysis of work production and work product” (Grimes, p. 16). Through this organizational framework, there is a clear “delineation of authority, responsibility, separation of planning form operations, incentive schemes for workers, managerial control, and worker specialization” (Grimes, p. 15).

Historians contribute much of the human relations movement and of industrial sociology to Elton Mayo with his famous Hawthorne Experiment in one of Philadelphia’s textile plants from 1927 to 1932 (Pugh & Hickson, 1997). Mayo found a strong correlation between work satisfaction and work production. Mayo believed “a social group with greater freedom in their work environment and control over their own work pace increases work satisfaction” (Pugh & Hickson, p. 139). An extensive study conducted by Mayo used six operatives who were removed from the norms of the work place and placed in a controlled environment and given the opportunity to voice their concerns about the development of their work environment. The controlled work environment also allowed for more social interactions in the workday (more work breaks) than under their normal work conditions. These collaborative efforts were intensified as the study continued thereby producing what Mayo suggested were informal practices or a set of beliefs, values, and norms-social relationships, which resulted in greater or



increased group cohesion. Mayo also extracted from this study that worker satisfaction depends to a large extent on the informal social pattern of the work group (Pugh & Hickson). The study also “showed that motivation was outside the boundaries of the systematic and logical and rational model” as first thought of by Fredrick Taylor (Grimes, 2006, p. 18).

Mayo recommended the following for the work environment: First, managers must not ignore the informal organization but ensure its norms are in harmony with organizational goals. Second, man is basically motivated by social needs, not economic ones. Third, work is rationalized by employees and meanings are sought in social relationships at work. Fourth, in order to influence the behavior of individuals, managers must focus on the work group rather than individuals. Fifth, effective supervisors are those who satisfy subordinates’ social needs. Sixth, the need for recognition, security and sense of belonging is more important in determining workers’ morale and productivity than the physical conditions under which the work. (Grimes, 2006, p. 43)

Grimes (2006) also stated that “the mistake that was made by managers was the replacement of the traditional theory with that of the human relations school as if one was a perfect substitute for the other, when in fact they were part of the same continuum” (p. 18). This brings the subject of motivation to the forefront where Fredrick Herzberg states, “the primary functions of any organization, whether religious, political, or industrial, should be to implement the needs of man to enjoy a meaningful existence” (cited by Pugh & Hickson, 1997, p. 136). Behavioral researchers such Abraham H. Maslow, Fredrick Herzberg, and Victor Vroom have explored the human psychology of motivation while

others such as Rensis, Likert, and Robert Blake have studied leaders and leadership to ascertain what others have concluded concerning the ambiguous subject of motivation.

The question remains: How and what does a manager or leader of an organization need to do to provide a suitable work environment for their workers? Douglass McGregor suggested that “The average human learns under proper conditions, not only accept but to seek responsibility” (as cited by Pugh & Hickson, p. 145). The researcher takes a closer look into what motivates employees to engage in work activities that produce viable social-interpersonal work relations that result in JS using McGregor’s Theory X and Theory Y. Theory X provided what some would call the internal pessimist view of human behavior:

a) People in general have a strong dislike for work; b) management stresses productivity; c) people in general need to be coerced, threatened, manipulated, and controlled to accomplish organizational objectives; d) people in general have little ambition, avoid responsibility, and desire security; and e) ordinary people do not inherently dislike work.

McGregor’s Theory Y provides the natural instinctive behavior of humans, who not only accept, but seek responsibility:

a) Physical and mental work is natural, b) people can exercise self-control and pursue self-direction in order to accomplish given objectives; c) most humans seek *both* significant rewards and strive for self-actualization; d) people are willing to contribute to solutions of organizational problems; e) workers need to identify through relationships; and f) work needs to be meaningful. (Grimes, 2007, p. 46)

Abraham Maslow's Hierarchy of Needs essentially agrees with McGregor's Theory Y, but narrows the human behavior down to basic needs essential to the human development of most individuals. The basic human needs revolve around the following: (a) the physiological need for hunger and thirst, (b) safety that results in security, (c) love and belonging, (d) self-esteem or self-respect, and (f) self-actualization or a desire to fulfill "life-long dreams" (Grimes, 2006, p. 44). The social environment of humans distinctively creates a social movement or direction determined by the values and needs of the group. Motivation of humans, however determined, are intrinsically embedded into the purposeful movement of an individual's mind guided possibly by human will, personal perception, or past experience.

Individual psychologist Alfred Adler was an influence for many psychologists such as Carl Rogers, Abraham Maslow, and Carl Jung. Adler was a physician, social theorist, psychologist, and educationalist (Hooper & Holford, 1998). Adler believed all human behavior is goal oriented and all behavior is socially-embedded; nobody exists outside society. Adler also believed, "the basic human drive is towards mastery and power in life in order to move from inferiority to superiority" (Hooper & Holford, p. 79). Within Adler's socialization theory is his approach to understanding children's behavior, providing what may be the basic definition for understanding human motivation. Adler believed children are nurtured, stating "Children are not born good or evil, but can be influenced in either direction" (Hooper & Holford, p. 30). Children live based on their experiences, perceptions, and beliefs about the world around them. A child's behavior is purposeful and has a goal. Movement and consciousness go together according to Adler, thus humans (adults) are constantly in motion, moving toward goals, which are private to

the individual and are often unconscious (Dewey, 1991).

The social developments individuals follow from infant to adulthood provide us with established behavioral patterns, which in turn give us predictors of adult movement, and also provide researchers with feasible reasons why adults move toward a perceived goal. This theory of social embedded behavior, however stated, has merit. Adults are motivated by a basic human drive either toward mastery, power, and/or superiority. Adults are in constant motion within their social environment, whether consciously or unconsciously thriving to live and succeed in the way that is predicted by human behavioral patterns (Dewey, 1991).

As mention before, Adler's theory posits that the basic human drive towards mastery and power in life can be demonstrated by individualized movement toward a perceived goal (Dewey, 1991). In each individual's life, whether or not their goal is known or unknown in their own mind, there exists the desire or will to achieve the perceived goals leading to importance, success, and superiority. Thus each person strives to understand the world around them and their basic instinctive mode allows social theorists and psychologists the opportunity to study the mental, physical, and social processes of how the basic instinctive will, desire, or motivation of men and women to live and thrive within the social frameworks of family, home, community, and work function (Dewey).

It is through Adler's theory of basic human drive towards mastery and power of life that we can deduce the importance of Fredrick Herzberg's statement that "the primary functions of any organization, whether religious, political, or industrial, should be to implement the needs of man to enjoy a meaningful existence" (Pugh & Hickson,

1997, p. 136). Herzberg's work caused him to believe that by enriching jobs to create the above hygiene factors, there will be greater JS. Job enrichment calls for vertical job loading, in which opportunities for achievement, responsibility, growth, and learning are designed into the job (Pugh & Hickson).

We can deduce from the literature review that the motivation of humans, whether it is innately driven and/or socially embedded, is a basic force and seems to lie in the social fabric of humans. Whatever the need, motivation to satisfy the need is usually strengthened by the "informal practices or a set of beliefs, values, societal norms, and social relationships" of humans reinforced by the "need for recognition, security, and a sense of belonging" (Grimes, p. 46).

#### *Recent Public School Developments*

In the last several years, public schools, including rural and urban middle schools, have come under public and governmental scrutiny by federal and state legislatures. The federal No Child Left Behind Act (NCLB) 2001 essentially holds local school districts to high standards. The state of North Carolina uses the ABC's model for growth and proficiency to measure how well schools perform on the End-of-Course tests and End-of-Grade tests. Middle school performance each year is determined by several factors, primarily student proficiency in the areas of Reading End-of-Grade Tests for sixth through eighth grades, Writing End-of-Grade Tests for seventh grade, Math End-of-Grade Tests for sixth through eighth, and End-of-Course Tests in Algebra I and Geometry. The North Carolina State testing formula is based on the tested number of sub-groups each school has within their school. A tested sub-group is made up of 40 or more students. The six sub-group categories are as follows: gender, all ethnic groups,

exceptional children, English as a Second Language, migrant students, and economically disadvantaged students. All public schools, including middle schools, are evaluated by the State of North Carolina by how much each of those sub-groups vary during End-of-Grade and End-of-Course Test performances. Each school must meet state performance and proficiency standards as a whole school to meet Adequate Yearly Progress (AYP).

The sub-group categories are defined in the following ways:

- 1) Gender: Male and Female
  - 2) Economically disadvantaged: students who qualify for free and reduced price school meals.
  - 3) Major racial and ethnic groups: students who are American Indian, Asian/Pacific Islander, Black, Hispanic, Multi-racial, and/or White.
  - 4) Students with disabilities: children who are physically or mentally handicapped due to a temporary or permanent health condition, which also includes 504 students (students identified with other health impairments that cause impairments or hindrances to the educational process.)
  - 5) Limited English Proficiency (LEP): students whose primary language is other than English, and whose proficiency in English is limited, leaving them to receive instruction exclusively in English.
  - 6) Migrant Students: students who are engaged in or who have parents or guardians who are engaged in agriculture work. The student must have moved within the last 36 months to acquire temporary or secure agriculture work. (NC School Report Cards, p. 2)
- North Carolina urban middle schools whose demographics represent the majority

of the sub-groups have significant problems in reaching state academic standards. When schools fail to meet AYPs mandated by the federal government, the State Board places the school on a probationary plan and gives them a grace period to improve student achievement or face further federal and state sanctions. Title I Schools who serve a large percentage of low-income families face the same North Carolina ABC's accountability model and are expected to meet state standards. If they fail to do so, Title I Schools can be placed on academic probation. Title I Schools who have not met their AYPs for two consecutive years are categorized by the state as Schools of Improvement (NC School Report Cards, 2005-2006, p. 5).

U.S. Department of Education (2007) federal government reports state that Title I Schools are allocated funds based on the percentage of students on Free or Reduced Price Lunch. In addition, Title I Schools must allocate or set-aside 10% of the federal funds received for professional development to help address the issues or reasons why a Title I school became a School of Improvement. In addition, those local educational agencies who receive federal grants such as Title I must provide school-wide enrichment activities/programs to help low-achieving or lower socio-economic children meet state academic curriculum standards. Students who receive free or reduced lunch qualify to receive free tutorial services offered through professional educational agencies.

There are several factors when considering students' preparation before entering the school doors. The 11 middle schools for this study are Title I schools whose primary service is to under-privileged and/or at-risk students. The students come from neighborhoods associated with poverty, lower socio-economic status, and whose parents may or may not be well educated and/or may be on public assistance. The next section

provides insight to Student Readiness according to research of Greene and Forster.

*Student Teachability: Insight to Students Learning Before Arriving at School*

The impact of student readiness on student achievement is often a discussion of whether to blame the teachability of students or to blame the school's organizational ability to impact low-achieving students from lower socio-economic environments. Teachers' perspectives of the school's potential and actual school performance may rely on how teachers perceive the academic readiness of students as opposed to the school's organizational ability to impact student achievement. This research sees student readiness as an intervening variable, however, not quantified for this research, but for the purpose of the study, an important element in the overall discussion. Green and Forster (2004) created a systematic way to measure the teachability of students by using 16 social factors and then combining the factors into a single index. The six major components of the Teachability Index consist of the: Readiness Index, Community Index, Race Index, Economics Index, Health Index, and the Family Index (Green & Forster).

Green and Forster list 16 social factors: preschool enrollment, language other than English, parent's education, crime victimization, drug use, religious observance, residential mobility, non-Hispanic white, income, poverty, disabilities, mortality, low birth-weight survival, suicide, teenage birth, and single parenthood (p. 8). Ferguson (2006) stated that looking at a child's wellbeing through a SC lens can be beneficial. The research suggests that of all predictive factors that relate to a child's wellbeing, SC comes second only to poverty (Ferguson).

The Readiness Index measures how much academic preparation and support students receive before entering the school doors and how much education takes place



after school. The social factors for the Readiness Index include preschool enrollment, language other than English, and parents' education level (Greene & Forster, 2004).

According to the U.S. Department of Education, students who attend preschool are more academically prepared. Students whose parents speak a language other than English at home and/or who have difficulty speaking English will have a greater difficulty achieving the same level of academic achievement in the areas of reading and writing as their counter-parts (Greene & Forster). According the U.S. Department of Education, children of better-educated parents are more apt to receive early cognitive stimulation as well as ongoing academic support at home (Greene & Forster).

The Community Index measures the presence of helpful and harmful social influences in children's lives (Greene & Forster, 2004). Greene and Forster stated there are four factors: crime victimization, drug use, religious observance, and residential mobility. The United States Department of Justice reported that students who suffer from victimization are more likely to have difficulty learning (Greene & Forster). The U.S. Department of Health and Human Services reported that students who have ever used illicit drugs will be more difficult to teach due to the harmful side effects of drug use (Greene & Forster). In addition, the National Science Foundation stated that when families attend regular religious services, students reportedly are exposed to positive social influences resulting in teachable students. Residential mobility is the final factor or aspect of the Community Index. This involves families who have moved or relocated to another residence causing children to be separated from family, friends, and other familiar surroundings. The change of residence causes an emotional strain and decreases the student's ability to learn (Greene & Forster).

The Health Index measures the physical and mental wellbeing of students (Greene & Forster, 2004). There are four factors with the Health Index: disabilities, mortality, low-birth-weight survival, and suicide (Greene & Forster). The U.S. Department of Health and Human Services reported that children with disabilities are faced with various challenges to learning. In addition, mortality rates are indicators of the level of physical health conditions. When the mortality rate goes up in a neighborhood/community, the health of other children in the neighborhood worsens. Greene and Forster also stated that children of low-birth-weights are more likely to face or develop health problems that interfere with learning outcomes and have an effect on the teachability of the student population. Suicide tendencies result from a mental health condition and as suicide rates have increased, as reported by the U.S. Department of Health and Human Services, the mental health of the community has worsened, and the effect is that students will have a difficult time learning (Greene & Forster).

The Race Index measures the racial composition of the student population. Students of color or minority students face greater disadvantages and those disadvantages pose a special challenge to receiving quality education (Greene & Forster, 2004). According to the U.S. Census data, the percentage of the population that is non-Hispanic white is made up of 1%.

The Family Index measures the extent to which family structures impose educational challenges on children. Greene and Forster (2004) used two factors to create the index, teenage birth and single parenthood. The U.S. Department of Health and Human Services reported that teenage births reduce teachability in the student population. This is due to the difficulties that a teenager faces when fostering and nurturing a child.

Teenage births also cause other stressors that influence the teenager's mother. Significant amount of research in the area of teenage births and children raised with one parent in the home has contributed to empirical evidence surrounding teenage pregnancy and suggests it creates a significant challenge that hinders the learning process.

Family environment, according to Fitzpatrick and Wright (2006), is an important social factor regarding adolescent development and preferences. Parents who are involved in civic duties and participate in community organizations form external social bonds and allow the family unit to draw on those bonds when needed. The increased availability to SC strengthens parent perceptions, developing higher levels of mutual cooperation, trust, and monitoring (Fitzpatrick & Wright, p.1437).

According to Fitzpatrick and Wright (2006), dense extra-familial supportive networks formed through social relationships help maintain adolescent physical and psychological health. The density of the family and social ties increases the likelihood that parents will encourage the independence of their children when they perceive that outside sources such as teachers and other parents will monitor their adolescent's activities and report any suspicious types of behaviors (Aneshensel & Sucoff 1996; Bowen & Bowen 1999; Brooks-Gunn et al., 1993). In contrast, adolescents who are more prone to lash out or show aggressive and impulsive behaviors may be victims of violence or may have been repeatedly victimized in the past. Adolescents who lack strong family and social bonds with parents, teachers, and peers are more prone to lash out with aggressive or impulsive behaviors in their own efforts to cope with a perceived on-going threat to themselves (Fitzpatrick & Wright, p. 2).

Greene and Forster (2004) stated the Economic Index measures the wellbeing of

students. Students from lower socio-economic families are often challenged with obtaining the proper educational materials needed to aid their learning compared to their wealthy counter-parts. The two factors, income and poverty, are used to measure the economic index. Greene and Forster stated that states with low test scores do not indicatively produce low-performing students, and also states that high scores do not indicatively produce high-performing students; the relationship between student teachability and student performance varies from school to school. Greene and Forster reported in their findings that both school choice and accountability testing lead to higher student performance relative to student teachability levels.

In relation to the study, Fitzpatrick and Wright (2006) cited several researchers who posit that schools are social environments that provide students (adolescents) opportunities to form SC through both direct and indirect means. The researcher reminds the reader that middle school students are adolescents ages 12 to 15. Schools expose students to community resources and provide chances for students to interact with peers who will either be positive or negative influences (Fitzpatrick & Wright, p. 1437). Fitzpatrick and Wright say these unpleasant social interactions present an academic challenge and are often observed through a lack of confidence, low self-esteem, frustration, social detachment, and acts of aggressive behaviors. For many adolescents, the social exchanges between peers and teachers are difficult, often resulting in combative or avoidance types of behavior (Simon, Crosby, & Dahlberg, 1999 as cited in Fitzpatrick & Wright). Conversely, students who feel cared about by teachers and their peers and have healthy perceptions of fairness and justice are less likely to initiate violent behaviors (Resnick et al., 1997).

This is supported by Putman (2000) who states:

(a) Where there is high level of trust among teachers, parents, and principals, the key players are more committed to the central tenets of school improvement; (b) Teachers in high-trust settings feel loyal to the school, seek innovative approaches to learning, reach out to parents, and have a deep sense of responsibility for student's development; (c) Even after taking into count all the other factors that influence the odds of successful reform, trust remains a key ingredient in regards to educational reform initiatives (p. 305).

Putman's (2000) index shows a relationship between state SC and educational outputs such as SAT scores, achievement tests, and dropout rates, which allow researchers to see the important correlations drawn by Putman's research. North Carolina, ranks number 41 in the nation in SAT scores, achievement tests, and dropout rates. In addition, Putman's Social Capital Index is "highly correlated with student scores on standardized tests taken in elementary school, junior high school, as well as the rate in which students stay in school" (p. 299). Putman also suggests that the "informal social capital of a state is the strongest predictor of student achievement, not poverty or demographics" (p. 300). The social capital index includes the following: present low-birth babies, infant mortality rate, child death rate, deaths per 100,000 teens ages 15-19, teen birth rate ages 15-17, high school dropouts ages 16-19, juvenile violent crime arrest rate ages 10-17, percent of teens not working and not attending school ages 16-19, percent of children in poverty, and percent of families with children headed by single parent homes (Putman). States that score high on the Social Capital Index are states

whose residents trust other people, are involved in organizations, volunteer more often, vote, and socialize with other friends. In these states, the children flourish, babies are healthier, there is less teenage pregnancy, a low school dropout rate, less involvement in crime, and most teenagers who do not die prematurely (Putman).

In summary, student readiness factors are more likely than not to have an impact on teachers' perspective of the school's potential to achieve their goals as an organization, and although not a quantifiable variable for the study, one may deduce that student readiness may be directly related to a school's actual performance, as observed through the school's Adequate Yearly Progress, and North Carolina's ABC's accountability model. In addition, the student readiness factors and the empirical evidence that supports each individual student readiness index factor indicate numerous stress factors teachers face when teaching in Title I schools. A teacher's JS is in many ways influenced by student readiness, and the school's organizational ability to address each student's need is a constant factor, but for the purpose this research, it is an intervening variable, not a quantifiable variable.

#### *North Carolina Teacher Working Conditions*

Jones et al. (1999) surveyed 16 elementary schools across five North Carolina school districts to include a total of 470 elementary teachers to understand the teachers' views of North Carolina's ABC's accountability model for North Carolina Schools. How has the ABC's accountability model influenced teachers' morale and attitudes toward teaching? Of instruction, teachers' estimated amount of time spent teaching reading, mathematics, and writing had increased, and less focus was placed on science and social studies. Also, the effects of standardized testing, according to the teachers, included the

following results:

- (a) More than 76% of the responding teachers felt that their jobs were more stressful than before the implementation of the accountability model, (b) 77% felt that their morale was lower, and (c) 76% of the teachers surveyed felt that the North Carolina ABC's accountability program would not improve the quality of education. In addition, the teachers surveyed did not believe that the standardized testing takes into account factors such as English proficiency, socio-economic status, and ethnicity. (Jones et al., p.199)

The researchers cited Dickson Corbett and Bruce Wilson in their studies that suggested teachers' morale would drop and teachers would eventually leave the low-performing schools at a time when there is a shortage of teachers nationally and locally in North Carolina. So, the question is, how important is the working environment for teachers? Hirsh et al. (2006), authors for the report by the Center for Teaching Quality, state, "working conditions were the strongest predictors of middle schools meeting or exceeding growth expectations" and teachers in middle schools "in which 80 percent of the faculty agree that there is an atmosphere of trust and mutual respect are 2.2 times more likely to meet or exceed academic growth expectations" (p. 12). The school's organizational ability to work through staff and student issues is reflected on the North Carolina Annual Report Card for each North Carolina school, which reported students' demographics and overall student achievement in comparison with other local school districts within the state. Hirsh et al. cited data analysis collected on a 2004 North Carolina Teacher Working Conditions Survey in which schools who demonstrated positive, supportive environments employed teachers who reported that they are in

partnership with school leadership. Also, the “2004 data showed that schools where teachers agreed that these critical conditions were in place were more likely to receive a top designation on the state’s ABC’s student performance measure and make Adequate Yearly Progress (AYP) (when controlling for student poverty, school size and other factors)” (Hirsh et al., p. 1).

#### *Relationships Examined in the Study*

The study examined the relationship between SC and teacher self-report of JS. The researcher hypothesized that as the teacher's perceived level of SC increased, so would teacher JS. Each school’s potential school performance is based on how well the school attains or accomplishes the goals stated in the school’s School Improvement Plan (SIP). At the local level, the SIP stands as a collective agreement between the teachers of the school, school administration, and district support services on agreed-upon target goals directed towards improving student achievement. The outcome of a school’s success is its organizational ability to attain or reach the goal of meeting all of the school’s AYP goals. So, the school’s actual performance each year is determined by several factors, primarily student proficiency in the areas of Reading End-of-Grade Tests for sixth through eighth grades, Writing End-of-Grade Tests for seventh grade, Math End-of-Grade Tests for sixth through eighth grades, and End-of-Course Tests in Algebra I and Geometry as reported in each school’s report card. Given the collective agreement among the teachers, the School Leadership Team, and school administrators there exist an understanding that all participants will work collectively to achieve the task agreed upon. The social interactions amongst the participants, their perceptions of the LO, and how they associate their perceptions within the working environment is the focus of the



study. The teachers' perspectives of the schools' potential and actual performance is however, an intervening variable, not a quantifiable variable for the study.

The research shows the strength of the relationship between SC and teacher JS. This research serves as a model for achieving greater levels of SC (organizational performance of a LO) and its relationship to teacher JS. As the research of SC continues and its impact on educational trends moves forward, the understanding of SC of the LO on JS may provide more insight as to how education leaders may better organize their teaching and support staff to reach the school's potential as a LO and ultimately meet expectations set by the federal mandate of NCLB (2001) and the AYP goals set for each middle school. The independent variable, SC is a significant concept in determining the effectiveness of an organization. Leana and Pil (2006), professors at the University of Pittsburg, stated that SC consists of three interacting facets, which work together to improve the transfer of knowledge among its members, resulting in better organizational performance.

These interactive relationships among teachers are established through collegial collaboration, mutual trust, and team cohesion. These facets of interactive relationships are in connection through the perceived moral arrangements and, ultimately, develop the working culture. Leana and Pil (2006) conducted a study of 88 urban middle schools in Pittsburg, Pennsylvania over a 3-year period. In addition, SC and its relationship with performance at the organizational level were evaluated to determine if SC could improve the overall effectiveness of a school's performance.

In the final part of their report, Leana and Pil (2006) stated that "social capital is a context-specific phenomenon," which affects the worker's output, the internal workings

of the organization, and how the organization will respond to the environmental and human needs of the staff and students. Lee (2005) cited Tsai and Ghoshal who quantified the levels of social capital by using network measure of “betweenness” within the individual social interactions within a firm (organization). The following questions were used by Tsai and Ghoshal to assess personal SC within a firm (Lee, 2005). The questions are closely associated with Bowen and Powers (2003) 44-item questionnaire (actions and sentiments) on the Learning Organization Profile measurement instrument.

Structural Dimension questions included:

- 1) How expansive is your network of business connections?
- 2) How are you positioned within your organization’s networks?
- 3) Do you have many peers? (i.e. member of a closed community.)
- 4) Do you effectively span multiple areas?
- 5) Do you have a few, very close connections, or a large number of weaker connections? (Lee, p. 20)

Structural perspective within an educational setting, teachers with a large number of ties covering several school departments, are better suited to expand or transform their knowledge base, generating a greater organizational advantage for the learning organization. Leana and Pil (2006) cited several researchers stating “trusting relationships allow transmission of more information as well as richer and potentially more valuable information” which in turn provides the characters more opportunities to engage in interactive and reflective dialogue that benefits the organization and the individuals that work in them (p. 354).

Relational Dimension questions were:

- 1) Do you consider yourself a trusted partner to most of your connections?
- 2) How trustful are you or your own connections?
- 3) How committed are you to “returning favors”? (Reciprocity)
- 4) Would you sacrifice a business relationship to meet a financial target?
- 5) How open are you in your business dealings?
- 6) Do you accept criticism easily?
- 7) Do you welcome diverse opinions from your connections? (Lee, 2005, p. 20)

The relationships construct measures how open and honest a person is within their work environment. How well do you identify with your peers and what level or degree of trust in those working relationships?

Cognitive Dimension questions included:

- 1) Do you participate in developing a “shared language” with your business connections?
- 2) Do you regularly share stories and anecdotes from and between your business connections?
- 3) Do you regularly persevere in dialogue with your connections to the point where shared understandings and visions are achieved? (Lee, 2005, p. 21)

Cognitive Dimension measures how engaged teachers are in connecting with their colleagues, sharing important issues or opportunities that focus on mutually desired outcomes. Leana and Pil (2006) cited Mohammed and Durnville who suggested that the cognitive construct of SC strengthens and reinforces structural and relational dimensions of SC.

*Schools as Learning Organizations*

Educational institutions have well-defined systems, structures, and frameworks that are important hallmarks of the internal and external workings of organizations. Schools are LOs with an embedded working body of knowledge, assets, and resources to assist teachers with their instructional and non-instructional duties. School policy manuals, operational procedures, databases, communication exchanges, products, and services are examples of structural systems within a school setting to assist with day-to-day operations (Subramaniam & Youndt, 2005). Much of what information flows within the organization is embedded into the socially acceptable or unacceptable norms, creating a culture within the LO.

Individuals who make up the organization, such as public schools, have specific job descriptions and are responsible for carrying out the mission of the organization. Schools as LOs are responsible for educating students to the degree or standard of proficiency. In doing so, individuals such as teachers and school administrators must communicate with their colleagues, other educational departments, district and state supervisors, customers (students), and outside community agencies in efforts to accomplish the set mission-educating students.

Senge asserted that LOs “have the ability to renew themselves based on information processed by the organization” (Kuusisto, Helokunnas, & Ahvenaineh, 2003, pp. 202-203). Sharing information or transferring knowledge with constituents over a period of time builds associations, and the strength of those associations or relationships is based on a level of trust and trustworthiness. According to Applehans, “Knowledge is the ability to turn information and data into effective action. It is the capacity to act”

(Applehans cited by Kuuisto et al. p.202). The individual knowledge and experience each person brings to an organization is vital to the success of the company and is an important component of SC. Although the individual abilities and characteristic attributes of teachers can be described in numerous ways, in this study, the definition is limited to what Subramaniam and Youndt (2005) define Human Capital as: the “body of knowledge and experiences each person brings to the organization” (p. 451).

Furthermore, the impact of SC of a LO on student performance suggests that the social interaction among the school staff is a determining or viable factor or variable that affects a school’s organizational effectiveness to positively affect or influence student achievement resulting in excellent school performance. Effective organizational performance of a middle school model relies heavily on those teacher interactions and the relationships that are formed over a period. Over a period of time, it is possible that teacher relationships will become more solidified, thereby resulting in better collaborative and collective efforts. The specifics of the mission are outlined in the School Improvement Plan, which alone is strictly a plan, until a consolidated and collaborative effort is made by those participants to complete and accomplish the objectives stated in the SIP.

This study focused on looking closely at the interactions of teachers and their work relationships using the three constructs of SC to discover if there are, in fact, correlations between those relationships within the LO and teacher JS. The information gained from this research is vital to both administrators and teachers and it serves to assist in the planning, developing, and building of stronger schools with the appropriate organizational staff to meet needs, especially for those students who come unprepared for

school and have low teachability indicators. In addition, the research is resourceful in meeting the needs of the entire school staff, especially teacher satisfaction, within the current teaching position. The teaching and learning process, however, involves many factors for both the teacher and the student. The teaching factors include teacher preparation prior to entering the teaching field, actual years of teaching experience, the number of years teaching in the same school, number of years teaching their assigned curriculum, and the present level of education. For the purpose of the dissertation, the factors mentioned are not be factors included in the data analysis as a quantifiable variable.

### *Summary of Chapter 2*

The literature research provided insight into the concepts of SC, LO, and JS. The interactive social relationships among individuals is basically rooted in each individuals value system, connected through cultural and structural norms that create opportunities for persons to act out their beliefs, for the purpose of receiving the rewards and benefits that are naturally embedded and/or perceived as viable resources. Leana and Pil (2006) stated that “social capital is a context-specific phenomenon,” which affects the worker’s output, the internal workings of the organization, and how the organization will respond to the environmental and human needs of the staff and students.

Schools are LO’s composed of individuals whose individual and collective efforts are connected through relationships. As research revealed, the trust and trustworthiness within the relationships is transmitted through individual values and norms. What motivates individuals in their connection to an organization is the organizations ability to provide ways for personal growth and development and sustain the agreed-upon norms.

Chapter 3: Methodology

*Introduction*

The primary research question for this study is as follows: What is the relationship between the three constructs of SC and teacher reported JS at 11 North Carolina selected urban and rural middle schools? The data set for the study was collected by Dr. Gary Bowen, Professor at UNC-Chapel Hill, in 2004 (Bowen Powers, 2003). Using a structural equation model (SEM) or an analysis of covariance structures, the researcher used Bowen et al., (2007) concept of LO and Nahapiet and Ghoshal's (1998) three constructs of SC for the development of a new conceptual model to explore what plausible relationships exist among the three SC constructs and the 12 LO dimensions. A second goal was to predict whether teacher self-report of JS is based on a perceived level of SC within an organization (a school) using an ordinary least squares regression model (see Figure 1).

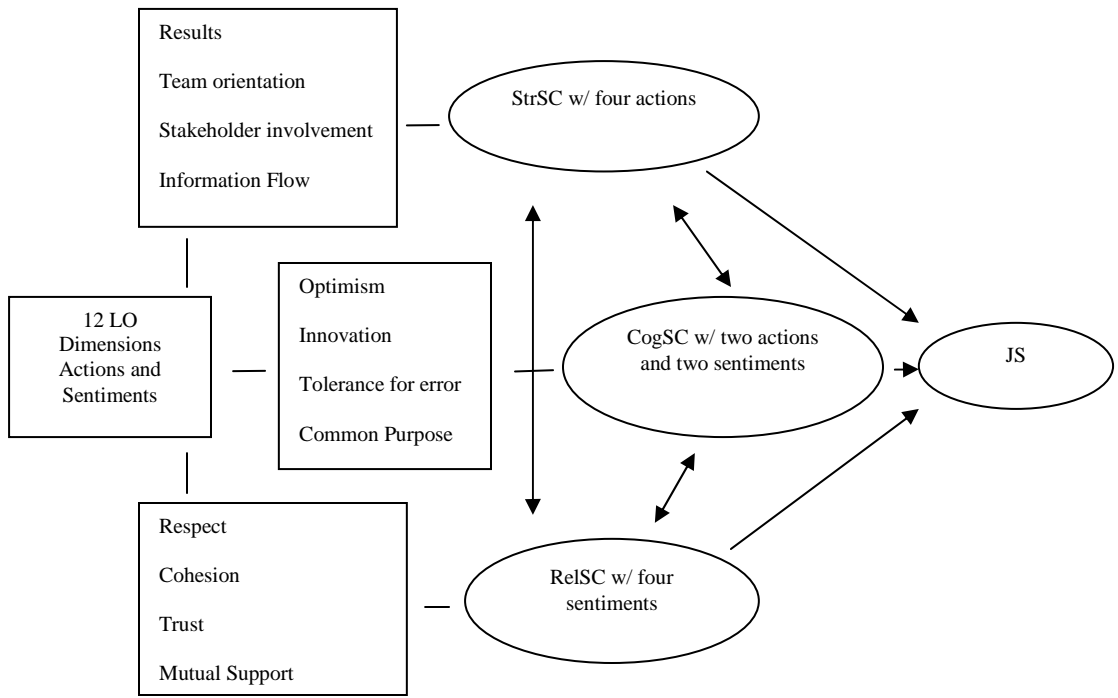

Figure 1. Conceptual Model with Proposed Relationships

Figure 1 illustrates the proposed relationships of the conceptual model. The model shows the expected relationship between StrSC and RelSC with both having a positive relationship with CogSC. Figure 1 also illustrates an anticipated linear relationship between CogSC and teacher self-reported JS. The three constructs of SC designed by Nahapiet and Ghoshal (1998) are defined by four dimensions associated with Bowen's 12 LO dimensions (six actions and six sentiments). The 12 LO dimensions are a part of Bowen's School Success Profile-Learning Organization (SSP-LO) instrument (Bowen et al., 2006). A comprehensive literature review of the application of the LO concept in public schools identified two domains. The domains are "actions and sentiments" (Bowen et al., 2006, p. 98). The survey consists of a 36 item questionnaire which is divided into two domains, six actions and six sentiments which capture the 12 learning capacities (manifest indicators). Using the expert input from Dr. Gary Bowen, the manifest variables were matched with the three SC constructs (latent variables): StrSC, RelSC, and CogSC. The Structural construct of SC (StrSC) consists of four actions: Team Orientation, Stakeholder Involvement, Information Flow, and Results, which make up the four manifest indicators. The Relational construct of SC (RelSC) consists of four sentiments: Respect, Cohesion, Trust, and Mutual support which make-up the four manifest indicators. The Cognitive construct of SC (CogSC) consists of two actions and two sentiments: Optimism and Common Purpose (actions), Tolerance for Error and Innovation (sentiments). It should be noted that the conceptual definition of each of the SC constructs was measured by the four manifest indicators assigned to each construct. The scale scores for the three SC constructs were derived by adding each dimension/individual score and dividing by the total. The linear relationship between



StrSC/RelSC/CogSC and teacher JS was predicted to be statistically significant.

### *Study Design*

The study was designed to answer four research questions. However, the researcher explored Dr. Bowen's SSP-LO instrument by examining the 36 items (questions), which are composed of 18 actions and 18 sentiments and their relationship to the 12 LO dimensions (and or latent constructs). In doing so, the researcher grasped a greater understanding of the SSP-LO instrument and its application to the conceptual theory linking the LO to the theory of Social Capital using the constructs, CogSC, RelSC, and StrSC.

In order to conduct this kind of theoretical research linking the theory of the LO to the theory of SC, the data application was conducted in phases:

Phase I used an Exploratory Factor Analysis (EFA) and Confirmatory Factor Analysis (CFA) to explore and examine the relationship between the 36 items (survey questions) and the 12 LO dimensions (6 actions and 6 sentiments).

Phase II used a Confirmatory Factor Analysis (CFA) which examined and determined the relationship that existed among the 12 LO dimensions and the 3 SC constructs.

Phase III consisted of scores from EFA and a Pearson Product Moment Correlation which examined and determined the interrelationships amongst the 3 SC constructs.

Phase IV used Ordinary Least Square Regression Model (Stepwise Multiple Regression) to determine what regression existed between the 3 SC constructs and JS.

Phase V consisted of the researcher using the data analysis to determine whether or not the prediction that there would be no difference between the population covariance matrix and the covariance matrix produced by the conceptual model was accurate.

#### *Structural Equation Measurement Model and Structural Model*

The measurement model accounted for the parameters set by the structural equation model. Thus it is important to understand the statistical path diagram. A path diagram with arrows was used to represent the data: A two-headed arrow indicates a variance among the latent variables, which, in this study, is the three SC constructs. The single headed arrow indicates a hypothesized pathway between two variables, hence a linear relationship. The curved lined without arrows between two variables indicates no directionality. The ovals indicate the latent variables and the rectangles/squares represent the manifest variables. A note of reminder, using a structural equation model frees the researcher to estimate and remove random errors from the latent variables, thus having only a common variance. The structural equation model was used in an effort to gain a useful understanding of the relationships between the variables and identify path relationships between variables (Stoelting, 2002). The structural equation model was used to analyze the relationships between the latent variables, minimizing random error. Hence, the first step of the statistical process was to start the values free from extraneous parameters. Polychoric correlations were used in the measurement and structural models. This type of correlation recognized the ordinal nature of the data and produced estimates that accurately reflect these relationships. Additionally, the skewness and kurtosis statistics were examined in order to determine which estimation technique is most appropriate. If the data were found to be approximately normal, then I planned to use the

maximum likelihood estimation technique. If the data were skewed, then I planned to use an asymptotically distribution-free estimation technique, such as a diagonally weighed least square. The hypothesis that the model fits the data was tested using chi-square test. It should be noted that chi-square is sensitive to large sample sizes, and it is not uncommon to find an insignificant p-value ( $p > 0.05$ ).

Therefore, the researcher examined one or more fit indexes from each of the fit families. The results of a confirmatory factor analysis allowed the statistical analysis of the structural equation measurement model to determine what fitting function was close to (0). A fitting function score of (0) implied the model's estimated covariance and the original sample covariance matrix were equal. If the covariance/variance matrix estimated does not adequately reproduce the sample covariance/variance matrix, hypotheses can be adjusted and the model retested (Stoelting, 2002). The statistical methods used showed whether the structural model adequately fit the predicted model.

#### *Ordinary Least Squares: Regression Model*

An ordinary least squares regression is a statistical method of choice to predict that a significant relationship exists between StrSC/RelSC/CogSC and teacher self-report of JS. The prediction was based on the literature review, indicating a significant relationship between the independent and dependent variables. Based on the findings of the confirmatory factory analysis, the researcher used the indicated scores of the three SC constructs and the scale score of the dependent variable to determine if there was a significant relationship to teacher JS. Using Bowen and Powers' 2004 data, the participants of the study who originally responded to, "Overall, how satisfied are you with your job at this school" (Bowen & Powers, 2003, SSP-LO) were calculated using a

continuous variable. The questionnaire responses ranged from very satisfied, satisfied, slightly satisfied, slightly dissatisfied, dissatisfied, and very dissatisfied. For the purpose of this study, the researcher counted JS as a continuous variable. Also, the p-value of the goodness of fit was predicted to be greater than ( $p > 0.05$ ). This statistical procedure allowed for the researcher to conduct an ordinary least squares regression model to examine the proposed linear relationship between the three SC constructs and JS. The operational definition of JS is directly related to the theoretical definition of JS, which regards the individual's perception and personal examination of their work environment.

Additionally, the standard error of measurement was examined to determine the confidence level of the proposed prediction. If the data found had a low standard error of measurement level, then the researcher had a higher confidence level to predict the strongest influence on JS. If the data found had a high standard error of measurement, then the researcher had a lower confidence level to predict the strongest influence on JS. Empirical research supports for the conceptual constructs are discussed in the next section along with the organizational and social theory to support the hypothesis of the study.

#### *Support for the Conceptual Linkages*

This theoretical study is rooted by three theoretical processes: social theory, organizational theory, and the learning organizational theory, all three of which are grounded in the foundations and principles governing interpersonal and intrapersonal relationships within living and working environments. The operational definition for Social Capital (SC) is the interactive-interpersonal relationships and the values placed on those relationships whose networking (collective sharing) provides leveraging to obtain a

collective, agreed-upon task (Adler & Kwon, 2002; Leana & Van Burren, 1999; Nahapiet & Ghoshal, 1998). Therefore, within the context of a LO such as a school, SC, according to Nahapiet and Ghoshal, the organization's capabilities to create and share information through existing structural networks (various dimensions of communications from person to person) provide an "organizational advantage" over other kinds of institutions (p. 242). RelSC construct measures the openness and honesty a person uses within the work environment. Within each relationship, the worker develops a degree of trust. Leana and Pil (2006) stated "trusting relationships allow transmission of more information as well as richer and potentially more valuable information," which in turn provides the characters more opportunities to engage in interactive and reflective dialogue that benefits the organizations and the individuals that work in them (p. 354). Concerning StrSC within an educational setting, teachers have several relational ties that cover one or several departments. Each relationship has the potential to expand or transform a teacher's knowledge and expertise, and, according to Leana and Pil (2006), this improved knowledge base provides a greater organizational advantage for the learning organization.

CogSC measures how engaged teachers are in connecting with their colleagues and sharing important issues or opportunities that focus on mutually-desired outcomes. The cognitive construct of SC strengthens and reinforces structural and relational dimensions of SC (Leana & Pil, 2006). CogSC therefore is the shared vision among teachers. As stated in the literature review, the interactive relationships among teachers are established through collegial collaboration, mutual trust, and team cohesion. Thus, the social interactions among teachers in a school are connected through the perceived moral

arrangements and, ultimately, develop the working culture. Leana and Pil stated that “social capital is a context-specific phenomenon,” which affects the worker’s output, the internal workings of the organization, and how the organization will respond to the environmental and human needs of the staff and students (p. 363).

#### *School Success Profile-Learning Organization: Instrument Reliability*

The reliability and validity of the SSP-LO instrument are reported verbatim for the purpose of maintaining instrument integrity and also to demonstrate how the identified latent variables used for the this study are originally part of Dr. Bowen’s 12 LO dimensions. The latent variables for the three constructs of SC are related by empirical evidence and expert opinion. Bowen and Powers (2003) reported the following instrument reliability for the SSP-LO instrument:

The two factors that emerged from Bowen and Powers (2003) analyses were examined for internal consistency using Cronbach’s alpha. Actions yielded an alpha a coefficient of 0.96. The sentiment’s reliability coefficient was .97. These reliability coefficients are considerably higher than the .70 threshold commonly specified as minimally acceptable in the literature and support the internal consistency of items composing the two factors. (p. 204)

#### *Instrument Validity*

Bowen used six employee items at the end of the survey. These items addressed perceptions of personal health, job satisfaction, self-efficacy for making a positive difference, school actual performance, school potential performance, and the likelihood of continued employment. Individuals scoring higher on actions or sentiments arguably might score higher on these six variables, although the present analysis examined only

the strength of association between the two domains of organizational learning and these constructs. Scores for actions and sentiments were developed for all cases complete on the 36 items and six variables (N=653) by summing item scores for appropriate items. On average, respondents scored on the positive side of the Slightly Agree range on both the action (R = 1-6, M = 4.34, SD = .94) and the sentiment (R = 1-6, M = 4.38, SD = 1.03) components. These computed variables were correlated subsequently with responses to the six employee items. The results, displayed in Table 2, offered relatively weak support for the construct validity of two learning organization factors. Although the correlations were all positive, they were in the low to very low range. The correlations ranged from a low of .02 (the relationship between sentiments and personal health) to a high of .30 (the relationship between sentiments and school performance). Only the correlations for personal health were not significant, although the large sample size contributed to the statistical significance of the other coefficients (Bowen, et al., 2007, p. 205).

### *Sampling*

The sample data in 2004 included a total of 761 employees who responded to the SSP-LO survey with an above 80% response rate (Bowen et al., 2007). The number of participants who responded from all 11 schools ranged from a low of 51 employees at one school to a high of 95 at the largest school. Most of the respondents (60.3%) were teachers. Administrators composed 4.5% of the sample; specialists, 6.6%; teacher assistants, 5.8%; and other employees, 19.8%. Current position for each participant was not reported by 3.0% of the respondents. Also, more than three-quarters (79.1%) of the employees had been employed at their respective schools for one year or more. Teachers in the original study made up 60.3% of the respondents totaling 761 employees of the 11

selected North Carolina schools. The data set for this study includes a total of 458 teachers out of the 761 school employees and 11 urban and rural middle schools in the southeastern part of North Carolina, which is depicted in Table 2.

Table 2

*Frequency Distributions of Sample on Relevant Demographic and Occupational Variables*

Current Position	Frequency	Percent of Total	Percent of total non-missing
Administrator	34	4.5	4.6
Specialist	50	6.6	6.8
Teacher	458	60.2	62.1
Teacher Assistant	45	5.9	6.1
Other Employee	150	19.7	20.4
Total non-missing	737	96.8	100.0
Missing	24	3.2	
Total	761	100.0	

*Note:* Table 2 shows current positions for the participants of the study.

Teachers make up 60.2% and administrators represent 4.5% of the total number of participants. Since this study was focused on the relationship between SC and teacher JS, the researcher focused on teacher survey responses.

The study allows the researcher to complete a quantitative analysis of the selected Title I Schools using data collected in 2004 by Bowen and his associates. The selected 11 middle school student demographic is associated with high levels of poverty. The selected 11 middle schools meet the federal government criteria to receive Title I Federal Funding along with Title III funds to address the ESL student population.



### *Source of Data*

The data collected for this study was originally derived from the 2004 School Success Profile-Learning Organization Inventory (SSP-LO) created and designed by Bowen and Powers (2003). The SSP-LO is a 44-item instrument, which includes a 36-item LO measure designed to discover the capacities or dimensions of a school as a learning organization. The SSP-LO takes approximately 12 to 15 minutes to complete. In May 2005, the SSP-LO was administered to 11 public schools located in two school districts in North Carolina, one in a rural area and the other in an urban area. The Behavioral Institutional Review Board at the University of North Carolina at Chapel Hill reviewed and approved all study protocols (Bowen et al., 2007). Each school in the original data set identified a coordinator who was trained to administer the survey. The completed surveys were returned in sealed envelopes. Each participant volunteered and was kept anonymous. Each building principal highly encouraged the teachers to participate and the principals also signed a letter of agreement to participate fully in the evaluation. The response rate exceeded 80%. In addition, there were no patterns determined in schools comparing profiles of respondents with non-respondents in terms of current position or years of service (less than one year, one year or more) (Bowen & Powers, 2003).

### *Data Analysis*

The researcher used the data gathered by Bowen et al., (2007) to complete a statistical analysis using statistical software programs to determine what relationship existed between three SC constructs and teacher-reported JS. A two-step covariance modeling approach was used to test the hypothesized model. A structural equation measurement was

used to examine the 12 dimensions of the LO dimensions and the three SC constructs. The researcher will use a confirmatory factor analysis to examine the measurement model-data fit between the following: StrSC and its four manifest indicators; RelSC and its four manifest indicators; and CogSC and its four manifest indicators. Second, the researcher used structural equation modeling to examine the relationship between latent variables: StrSC, RelSC and CogSC. Third, an ordinary least squares regression model with StrSC, RelSC, CogSC was implemented and teacher self-report of JS was analyzed to predict which relationship has the strongest effect on teacher JS.

### *Research Questions*

First Research Question (R<sub>1</sub>): What relationship exists between the twelve LO dimensions (manifest indicators) and the three latent variables; StrSC, RelSC, and CogSC? The Structural construct of SC (StrSC) consists of four actions: Team Orientation, Stakeholder Involvement, Information Flow, and Results Orientation, which make up the four manifest indicators. The Relational construct of SC (RelSC) consists of four sentiments: Respect, Cohesion, Trust, and Mutual Support, which make up the four manifest indicators. The Cognitive construct of SC (CogSC) consists of two actions and two sentiments: Tolerance for Error and Innovation (actions), Optimism and Common Purpose (sentiments). It should be noted that the conceptual definition of each of the SC constructs was operationally measured by the four manifest indicators assigned to each construct. The first research question was confirmed using confirmatory factor analysis. The researcher noted whether the confirmatory factor analysis would or would not allow for each latent variable to end up with four manifest variables.

Second Research Question (R<sub>2</sub>): What relationship exists among StrSC, RelSC, and CogSC? The second research question was confirmed by the correlational factor analysis.

Third Research Question (R<sub>3</sub>): How much variation in teacher self-report of JS can be attributed to the influence of StrSC, RelSC, and CogSC? The third research question was confirmed by using the ordinary least squares regression model.

Fourth Research Question (R<sub>4</sub>): The researcher predicted there would be no difference between the population covariance matrix and the covariance matrix produced by the conceptual model. The fourth research question was confirmed by finding a fitting function score of (0) between the structure measurement model and the structural equation model. As stated, a fitting function score of (0) implied the model's estimated covariance and the original sample covariance matrix were equal. Using a structural equation model, the researcher used the sample population and ran the SEM model to determine the fit between the 36 items and the 12 LO scales, the 12 LO dimensions, and the three SC constructs.

The research questions were designed to examine what the researcher predicted would be a positive relationship between SC and teacher self-reported JS at 11 selected North Carolina urban and rural middle schools.

#### *Limitations of the Study*

Student Teachability, according to Greene and Forster (2004), is the amount of preparation the students bring with them when entering each school year. The Student Readiness Index uses 16 social factors into 6 major components which measures how much academic preparation and support students receive before entering the schools and how

much education takes place after school (Greene & Forster). Teacher perspectives of the school's potential (measurable factor) and actual school performance (not a measurable factor for the study) may rely on how teachers perceive the academic readiness of students and whether or not the school has the organizational ability to impact student achievement. This research sees student readiness as an intervening variable, however not quantified for this research, but for the purpose of the study, an important element in the overall purpose of discovering and understanding the relationship between SC and teacher self-report of JS.

### *Principal Leadership*

Principals, in their efforts to strengthen the internal organizational structure of a school, not only realize the need for highly-qualified staff, but also understand that the positioning of each staff member will either build or diminish the school's ability to influence student achievement. The school principal connects his/her staff to district-level initiatives to support the school's mission to improve and increase student achievement, improve teacher JS, and improve efforts to retain highly-qualified teachers. The principal's drive to improve the effectiveness of the internal organization is reinforced in the North Carolina Teacher Working Conditions Survey conducted in 2004. Teachers reported the most important factors influencing whether or not they stay in their schools are when "their working conditions include positive, collaborative school climate, support from colleagues, and administrators" (p. 1). Therefore, principals and the entire school staff are responsible for building and developing the SC of a school to eliminate the presence or existence of a lack of trust, respect, and cohesion among school staff in efforts to create a positive, stable, and cohesive working environment to improve teacher working conditions which, according to the 2004 data, were important. More importantly, based on the correlations drawn from

the study, leadership and empowerment were related to improvement in student achievement.

The 2004 North Carolina Teacher Working Conditions Survey states explicitly that “schools where teachers agreed that these critical working conditions were in place were more likely to receive a top designation of the state’s ABC’s student performance measure and make Adequately Yearly Progress (AYP) (when controlling for student poverty, school size and other factors)” (p. 1).

### *School Leadership Team*

The School Leadership Team (SLT), also referred to as a School Improvement Team, works together as a cohesive unit to develop and design school-based plans to educate students and develop a learning environment for the students and a working environment for the teachers and school staff. Thus, the collective work of the SLT’s members and the implementation of its goals are, in part, a vital entity of the school. For each school, the principal identifies, within the body of teachers and school support staff, individuals that would contribute to successful implementation of the school vision by serving on a SLT. In addition, administrators must determine a strategic plan with the assistance of the SLT to assist with the implementation of the school’s overall mission to educate students. The 2004 North Carolina Teacher Working Conditions Survey made a suggestion to improve SLTs by ensuring that SLTs are addressing teacher concerns of empowerment and also meeting the new requirements of HB 1151 (duty free lunch and planning period), and additional support from the North Carolina Department of Public Instruction in efforts to provide more structured guidance and technical assistance to SLTs (Easley, 2008). The researcher recognizes the significant purpose for establishing a SLT

and the various impacts each SLT can have on student achievement, organizational effectiveness, school culture, and school climate. However, each school develops and utilizes their SLT in different capacities and, for the purpose of this study, each school's SLT will be considered a confounding variable, not quantifiable for the study.

### *Intellectual Capital*

According to Subramaniam and Youndt (2005), Intellectual Capital (IC) is composed of three distinct aspects, interrelated in many ways, but distinct in their impact on organizational capabilities. IC is composed of human capital, organizational capital, and social capital. Hargreaves (2001) stated that both concepts of IC and social capital provide a leverage system for the organization system, resulting in increased institutional outputs. In comparison, Anthony Kelly (2004) stated, "intellectual capital brings people and ideas together in a deliberate manipulation to create value from the transfer and codification of knowledge" (p. 626). Susan Madsen (2001) suggested "one of the most important keys for improving individual and organizational performance is in developing and strengthening intellectual capital and exploring the similarities and differences between concepts of intellectual capital, human capital, and knowledge management" (p. 17). The researcher acknowledges the complexity of the concept of IC and sees how IC can be interchanged with the concept of SC. For this purpose, the researcher limits the study by relying on the idea that IC is a significant part of understanding social capital and for the purpose of the study, IC is an intervening variable, not quantifiable in the study.

### *Human Capital*

Human Capital (HC), for the purpose of the study, is limited and cannot be measured as a single entity; however it is critical to understand the link to SC. Coleman defined HC as

“the acquired knowledge, intelligence, common sense, personal abilities and talents housed within a particular person” (Ferguson, 2006, p. 7). Hargreaves (2001) stated that HC is usually measured by the level of education and skill of a company’s staff, and for the purpose of the current study, HC is limited by reason of the North Carolina Department of Education by order of the NCLB (2001) federal mandate which requires collegiate course work, formal testing, a college degree, teacher certification, and state licensure. With this in mind, it is easy to see that “human capital is inextricably tied to social capital” (Subramaniam & Youndt, 2005, p. 459) and is a vital element in understanding the concept of social capital; however HC was not measured as a quantifiable variable for the study.

### *Delimitations*

The researcher delimited the study by focusing on the constructs of SC and its relationship with teacher JS. IC was not be observed as the composite of social, human, and organizational capital; however, the elements of each were mentioned and discussed throughout the dissertation and may be cause for further study.

In further efforts to delimit the study, the research covered two major elements of Subramaniam and Youndt’s (2005) work on HC and SC and their influence on organization performance. Schools are social organizations with individuals (teachers) who bring their knowledge and experiences into the workplace. Individual teachers possess the ability to share, collaborate, and collectively participate in the success or failure of an organization. Schools rely on the abilities of teachers and their interactions with one another to assist schools with educating students. The focus of this study is to determine if a relationship exists between SC and teacher JS. Subramaniam and Youndt support the direct relationship of SC and JS by stating, “Human capital is inextricably

tied to social capital and that social capital appears to be the bedrock of innovative capabilities” (p. 459).

According to Subramaniam and Youndt (2005), SC in an organization improves the incremental capabilities (Example: improving or refining existing organization structure, its products and services) and generates radical capabilities, that significantly transforms existing products, services, and at times dismantling the old ideas and replacing them with new innovative ideas. (p. 452). Thus, researchers are striving to understand an important link between HC and SC to ascertain individuals’ social interactions within an organization in an effort to improve the organizations effectiveness.

The schools are held accountable for adhering to local school district policies and procedures. The selected schools for the study have access to district-level operational and instructional manuals and data-based systems. The criterion for certified teachers is federally mandated and is a required policy standard for Title I Schools. In addition, Highly Qualified Teachers is currently a mandate set by the State of North Carolina and governed by the NCLB standards for hiring teachers and administrative staff. The researcher did, however, mention in the dissertation teachers’ perception of the schools’ potential and actual school performance and the various influences on teacher JS and student achievement, but these are not quantitative factors for this particular study. Also, student readiness (teachability) was noted and explained in the dissertation, an intervening variable, however, not used in the quantitative statistical analysis.

The study allowed the researcher to complete a quantitative analysis of the selected Title I Schools using data originally collected in 2004 by Bowen and his



associates. The research was delimited by the selection of the 11 middle schools and the student demographics associated with high levels of socio-economic poverty. Also, the selected 11 middle schools meet federal government criteria, which allow each school entitlement for either Title I Federal Funding for lower SES students and or Title III funds to address English as a Second Language (ESL) to address the needs of the students.

## Chapter 4: Data Analysis

### *Introduction*

The sample data in 2004 included a total of 761 employees who responded to the SSP-LO survey with an above 80% response rate (Bowen et al., (2007). The number of participants who responded from all 11 schools ranged from a low of 51 employees at one school to a high of 95 at the largest school. Most of the respondents (60.2%) were teachers. Administrators composed 4.5% of the sample; specialists, 6.6%; teacher assistants, 5.8%; and other employees, 19.8%. The current position for each participant was not reported by 3.0% of the respondents. Also, more than three-quarters (79.1%) of the employees had been employed at their respective schools for 1 year or more. Teachers in the original study made up 60.2% or 458 teachers of the respondents totaling 761 employees of the 11 selected North Carolina schools. For the purpose of anonymity, the participants' gender, race, and age were not included in the original data set.

### *Descriptive Statistics*

Using descriptive statistics, the researcher ascertained relative demographic information using the AMOS statistical program for the purpose of reviewing, exploring, and analyzing quantitative relationships to grasp various associations with the data set. In Tables 3-6, the researcher illustrates sample distributions across several categories of demographic and occupational variables.

Table 3

*Respondents' Years of Experience at Their Current School*

Years in current position	Frequency	Percent of respondents
Less than 1 year	148	19.8
1 year or more	601	80.2
Total non-missing	749	100.0
Missing	12	
Total	761	

Note: Total percent missing 1.6%; Total participants 761.

Table 3 indicates a total of 749 responded to the survey questions. Of the 761 participants, 148 respondents have less than 1 year at their current school and 601 respondents were in their current position more than 1 year, representing 79% of the total respondents. The participants responded to the question: “How many years have you been assigned to this school?”

Table 4

*Social Capital Constructs*

Variable	N	Minimum	Maximum	Mean	Std. Deviation
Structural Capital	61	0	5.316	3.582	1.00
Cognitive Capital	61	0	5.592	3.836	1.00
Relational Capital	61	0	4.588	3.058	1.00
Job satisfaction	55	1.00	6.00	4.468	1.42

The results of Table 4 indicate that three SC constructs in relation to JS shows that all three SC constructs have standard deviation of 1.0 with JS reporting 1.42 standard deviation. Please note that the means of the Social Capital Variables, which were

computed as standardized factor scores with Mean = 0 and Standard Deviation (SD) = 1.0, have been adjusted so that their minimum values are 0.00 in each case.

Table 5

*Respondents' Intention to Continue Employment as a Discrete Variable*

<u>Intention to continue employment?</u>	<u>Frequency</u>	<u>Percent of respondents</u>
No chance	57	7.7
Very slight chance	39	5.3
Slight possibility	33	4.5
Some possibility	34	4.6
Fair possibility	28	3.8
Fairly good possibility	30	4.1
Good possibility	35	4.7
Probable	49	6.6
Very probable	53	7.2
Almost sure	89	12.0
Certain	292	39.5
<b>Total Respondents</b>	<b>739</b>	<b>100.0</b>

Note: Missing respondents 22.

The results of Table 5 show respondents' response to the question, "How likely are you to continue your employment at the school for another academic year?" Of the 761 respondents, 38.4% were certain to return to their current work position. 7.5% reported no chance of returning to their current position. The responses ranged from 5.1% to 11.7% indicating wide variance from respondents who reported a very slight chance of returning to almost sure of returning to their current school. The descriptive statistics for the sample on the 12 LO variables are represented in Table 6.

Table 6

*Descriptive Statistics for 12 Learning Organization Dimensions*

Variable	N	Minimum	Maximum	Mean	Std. Deviation
Teamwork	61	1.00	6.00	4.364	1.13
Innovation	61	1.00	6.00	4.309	1.09
Involvement	61	1.00	6.00	4.119	1.02
Information Flow	61	1.00	6.00	4.300	1.10
Tolerance for Error	61	1.00	6.00	4.320	1.03
Results Orientation	61	1.00	6.00	4.664	.96
Common Purpose	61	1.00	6.00	4.551	1.03
Respect	61	1.00	6.00	4.268	1.21
Cohesion	61	.80	6.00	4.300	1.13
Trust	61	1.00	6.00	4.218	1.16
Mutual Support	61	1.00	6.00	4.467	1.11
Optimism	61	1.00	6.00	4.530	1.03

Note: (N = 761))

*First Phase of the Statistical Analysis*

In the first phase of the data analysis, an Exploratory Factor Analysis (EFA) was conducted on the theorized relationships between the 36 items in Bowen's School Success Profile-Learning Organization (SSP-LO) questionnaire and 12 LO dimensions (latent constructs) representing the 6 actions and 6 sentiments in Bowen's model. After the results of the EFA were concluded, the 12 latent constructs (dimensions or capacities of learning) were entered into AMOS as a structural model to explore what relationships existed among the latent variables and the 36 items, as depicted in Figure 3.

The EFA was used in a manner that allowed the researcher to ascertain the maximum number of distinct factors that underlie a set of variables. This is accomplished by rotating (using the varimax method) successively larger numbers of factors (incremented by one each time) until one factor appears as an error factor. An error factor is one that has all loadings below .33, a rotated sum of squares of  $< 1.0$ , or does not have the highest loading for at least one variable on the factor. Once such a factor is found, the number of factors in the preceding solution is the maximum number that the data will support. This type of analysis is called a factor sustainability analysis (J. S. Kane, personal communication, August 8, 2009). This procedure used the 36 items and found that there was a maximum of 2 distinct factors underlying the data, not 12 as hypothesized. These corresponded perfectly with the action and sentiment items. The researcher performed another factor sustainability analysis separately on the action and sentiment items, hoping to reveal the 6 scales in each. Instead, these analyses found only one factor underlying each of the subsets of items theorized to relate to actions and sentiments, respectively.

Despite the EFA results indicating the absence of as many as 12 orthogonal constructs, it is still possible that the 12 constructs were present but substantially correlated, especially within the action and sentiment categories. The CFA procedure allows for such correlations between constructs. The results of the CFA analysis for the 12 LO dimensions (latent constructs) are summarized in Table 7.

Table 7

*Results of First CFA Analysis for the 12 Learning Organization Dimensions (Latent Constructs)*

Measure of Fit	Value
1. Chi-square test of minimum sample discrepancy:	
Chi-square	2728.891
p-value (df)	<.001 (df=564)
Chi-square/df	4.838
2. Incremental Fit Index	.912
3. Tucker Lewis Index	.901
4. Comparative Fit Index	.911
5. Root Mean Squared Error Approximation	.071
90% Confidence interval:	.068 - .074

The results presented in Table 7 indicate that there was an acceptable level of fit in the data between the theorized associations of the 36 items with the 12 LO constructs. The chi-square test for minimum sample discrepancy, although significant, produced a  $\chi^2/df$  ratio of 4.838 which is less than 5. A ratio of less than 5 is commonly used as an indicator of chi-square result that is consistent with adequate fit. This is used because the chi-square alone tends to be excessively liberal in rejecting the null-hypothesis of no difference between theorized and observed covariance matrices. The Incremental Fit Index (IFI), the Tucker-Lewis Index (TLI), and the Comparative Fit Index (CFI) measures equaled or exceeded the conventional standard for acceptable fit of .90. Root Mean Squared Error of Approximation (RMSEA) .071 fell below the conventional upper

limit of acceptable fit of .08. The RMSEA looks at the complexity of the model and adjusts its computation by incorporating the degrees of freedom. It may be concluded, therefore, that the theorized associations between the items and the 12 LO constructs fit the data analysis to an acceptable degree. The researcher therefore, continued with the next phase of the data analysis. The complexity of the theorized associations between the 36 items and the 12 LO constructs can be observed in Figure 2.



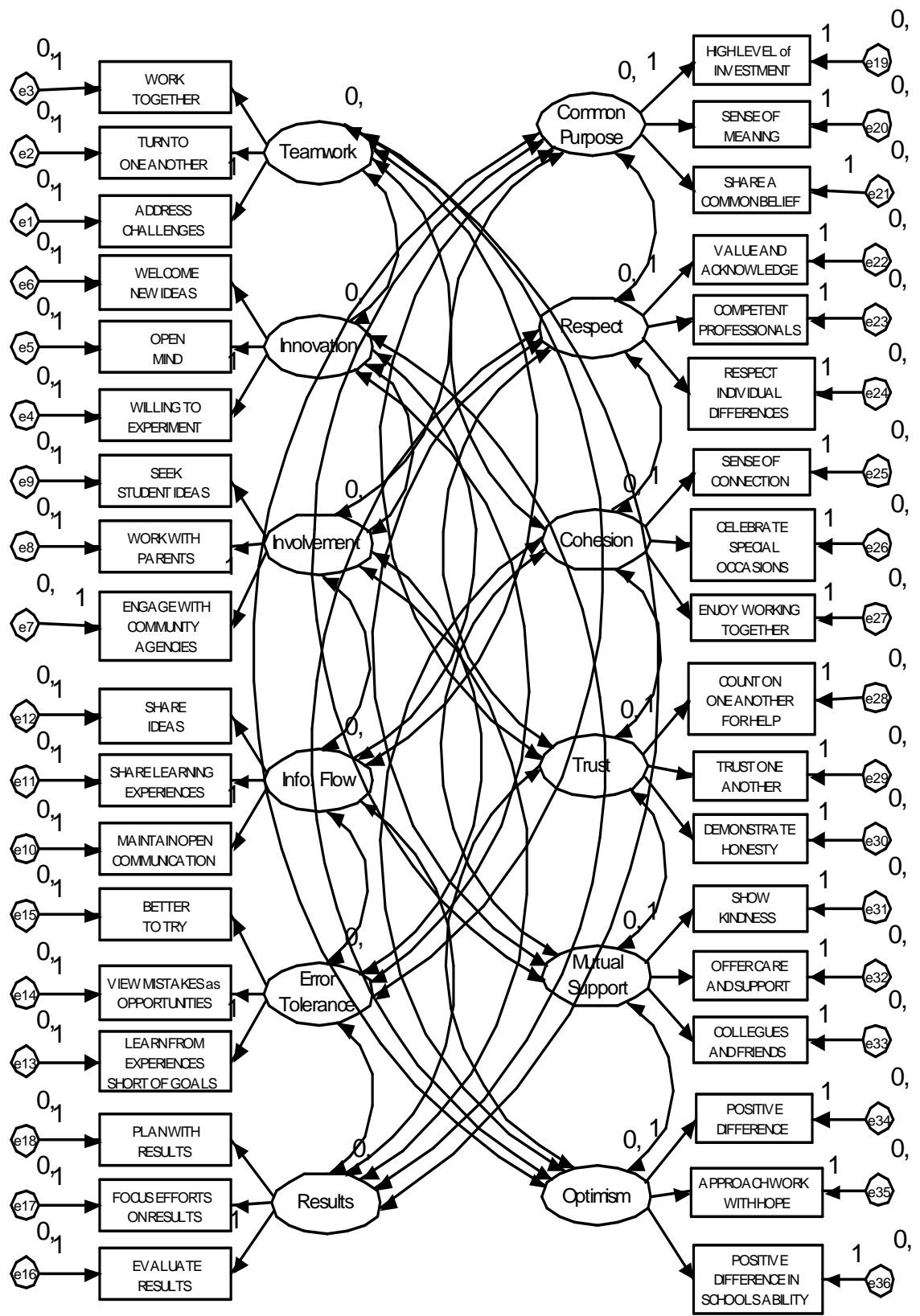

Figure 2. CFA Model for the 12 Learning Organization Dimensions

The action constructs to the left of the center of the CFA model were specified as being correlated only among themselves and uncorrelated with sentiment constructs to the right of the model's center, and vice versa. The decision to represent the two categories of constructs in this manner was based on a preliminary exploratory factor analysis, which produced two orthogonal constructs on which the items theorized to be associated with actions and sentiments were perfectly differentiated along those lines.

Normality tests were performed on the item data. The standard for assessing whether skewness and kurtosis fall within the limits of a normal distribution is that their values should be within the range of  $\pm 3.2$  index units ( $\pm 3.2$  index units in the indexes for skewness and kurtosis are the conventionally considered the outer limits of conformance to the normal distribution). This standard was met for skewness and kurtosis in the cases of all 36 items used in this study.

### *Second Phase of the Statistical Analysis*

The first research question: Is there a fit between the data and relationships theorized to exist between measures of the 12 LO constructs and the three SC constructs proposed was addressed by conducting an analysis to determine whether there was an acceptable degree of fit to the data of the Structural Equation Model (SEM) expressing the associations between the 12 LO dimensions (scales) measuring LO dimensions and the three SC constructs. These 12 LO dimensions and the three SC constructs were entered AMOS as a structural model, as depicted in Figure 3.

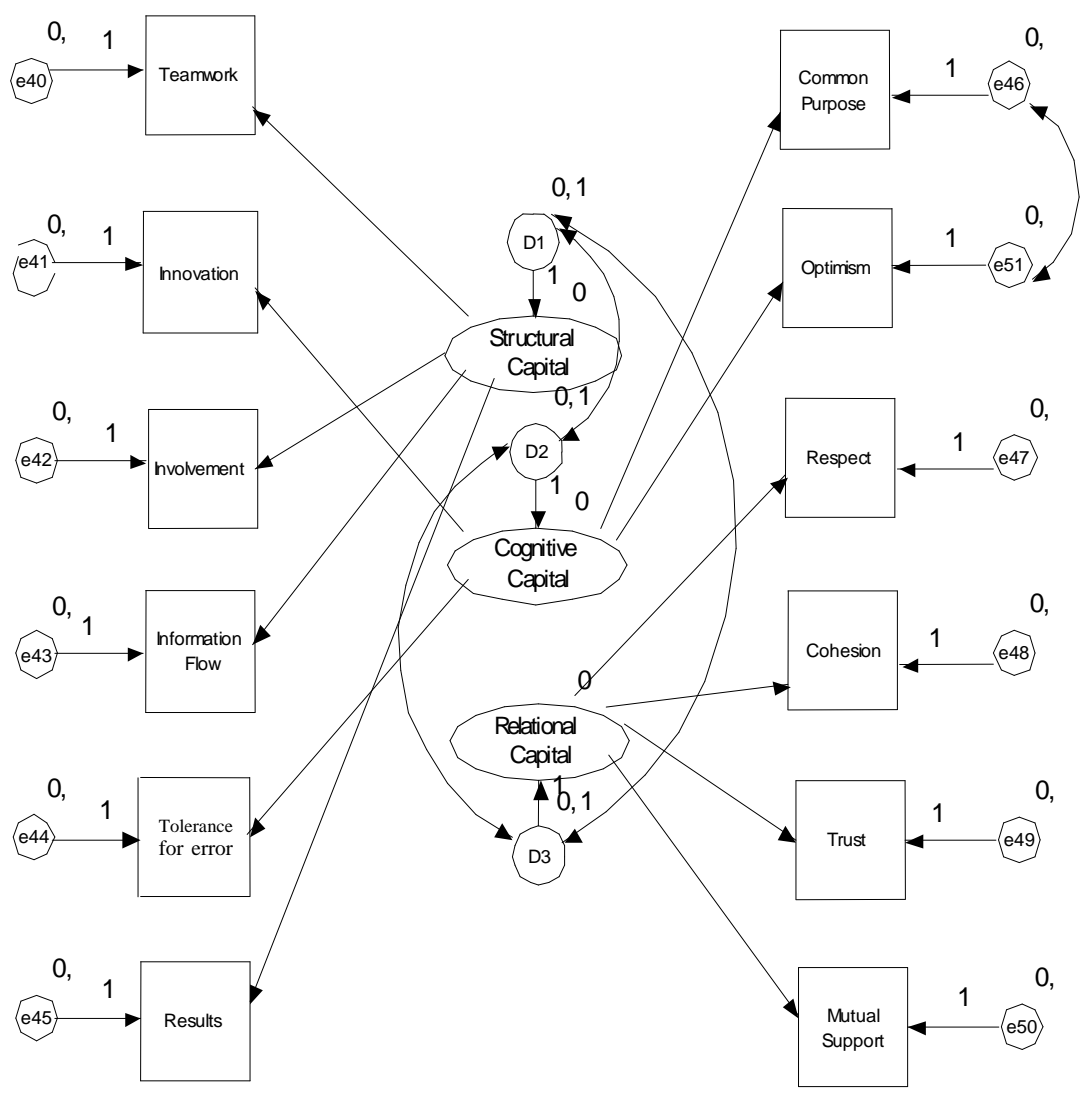

Figure 3. First SEM Model Without Relational Data (Regression Weights)

The 12 LO scales (dimensions) were formed by summing the scores on the three items associated with each scale. Normality tests were performed on the resulting scales. As was the case for the items, the skewness and kurtosis of each of the 12 scales fell within the limits of the conventional standard for normality of  $\pm 3.2$  index units. The next figure represents the SEM with regression weights and also relational data.

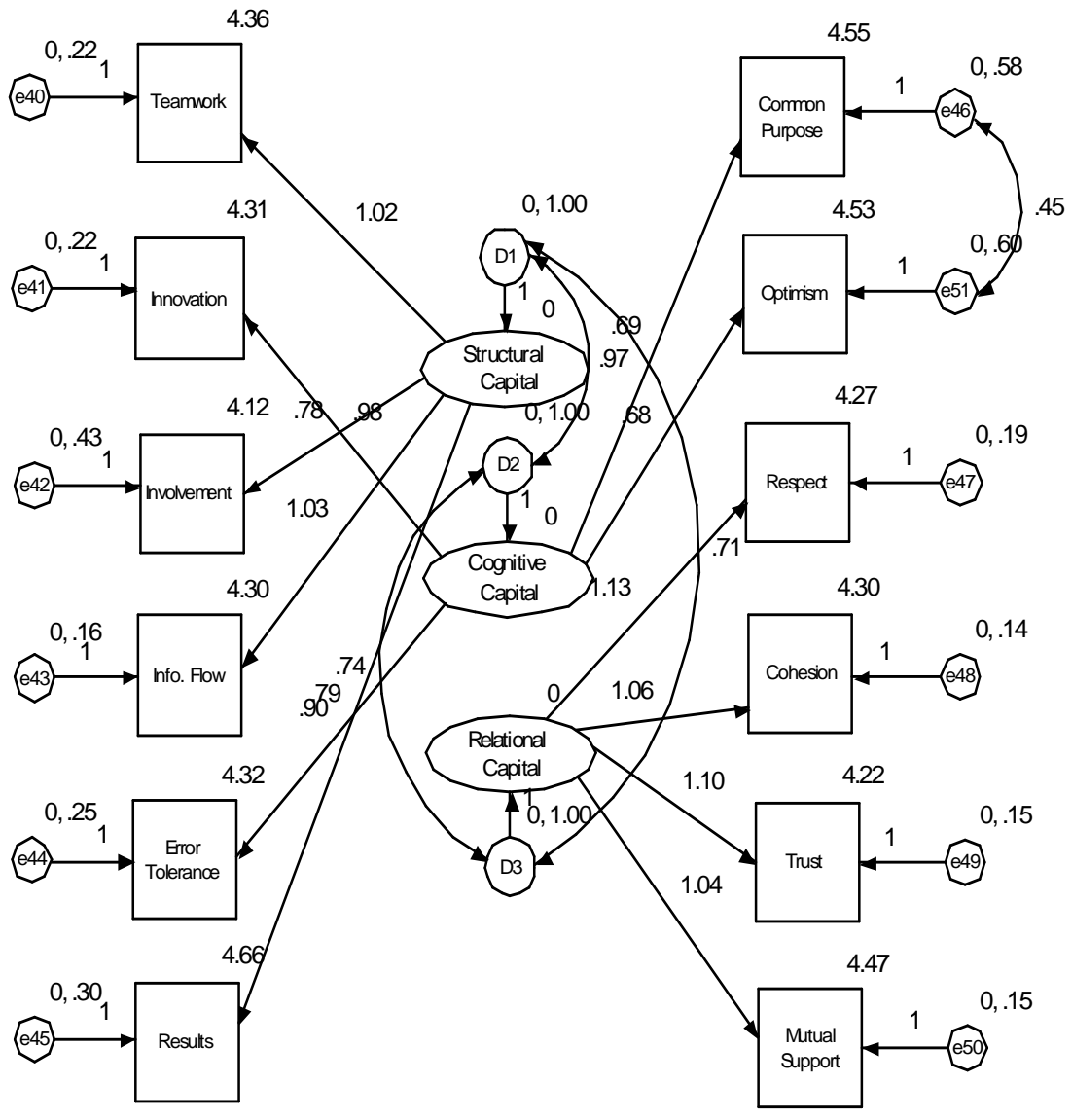

Figure 4. SEM Model With Relational Data (Regression Weights)

The results of Figure 4 can be seen in Tables 8 and 9.

Table 8

*Regression Weights for SEM Model*

12 LO Dimensions	Latent Constructs	Estimate	S.E.	C.R.	P	Label
TEAMWORK	Structural Capital	1.023	032	32.243	**	par_1
INNOVATE	--- Cognitive Capital	.977	031	31.622	**	par_2
INFOFLOW	--- Structural Capital	1.029	030	33.832	**	par_3
RESULTS	--- Structural Capital	.793	029	27.605	**	par_4
TOLERROR	--- Cognitive Capital	.905	030	30.299	**	par_5
INVOLVEM	--- Structural Capital	.779	032	24.682	**	par_6
MUTALSUP	--- Relational Capital	1.043	030	34.401	**	par_7
TRUST	--- Relational Capital	1.098	032	34.769	**	par_8
RESPECT	--- Relational Capital	1.130	033	34.130	**	par_9
CPURPOSE	--- Cognitive Capital	.691	034	20.608	**	par_10
COHESION	--- Relational Capital	1.064	031	34.719	**	par_11
OPTIMISM	--- Cognitive Capital	.679	034	20.053	**	par_15

Note: \*\*\* =  $p > .001$

All hypothesized paths between the three latent constructs and the four exogenous (12 LO dimensions) variables were highly significant. Table 8 shows the first SEM model with relational data indicating the regression weights relationships between the 12 LO dimensions and the three SC constructs.

The results of SEM analysis linking the 12 LO dimensions to the 3 SC constructs are presented in Table 9.

Table 9.

*Results of SEM Analysis Linking the 12 LO Dimensions With the 3 SC Constructs*

Measure of Fit	Value
1. Chi-square test of minimum sample discrepancy:	
Chi-square	700.495
p-value (df)	<.001 (df=50)
Chi-square/df	14.010
2. Incremental Fit Index	.940
3. Tucker Lewis Index	.920
4. Comparative Fit Index	.940
5. Root Mean Squared Error of Approximation	.131
90% confidence interval:	.122 - .140

The results presented in Table 9 indicate that there was an acceptable level of fit in the data between the theorized associations of the 12 LO scales (dimensions) and the 3 SC constructs. The chi-square test for minimum sample discrepancy was not only highly significant, but its  $\chi^2/df$  ratio (5.0) substantially exceeded the expected value for chi-square. However, the chi-square test is widely recognized as the most problematic of all the conventionally used fit measures. It is sensitive to sample size and particularly to the ratio between sample size and the degrees of freedom. As the latter ratio increases, it becomes increasingly difficult to retain the null hypothesis. Thus, in this case where the ratio is very high (i.e., 14), its indication of a high discrepancy between the predicted and observed covariance matrix should be regarded lightly. The results for the more refined fit indexes, IFI, TFI, and CFI are presented in subsequent rows in Table 9. The values for

these indexes are .940, .920, and .940, all of which exceed the conventional standard for acceptable fit of .90. On the negative side, the RMSEA measure exceeded its conventional upper limit of .08 for acceptable fit. Thus, it must be concluded that the degree of fit in this case is only minimally adequate.

### *Third Phase of the Statistical Analysis*

The third phase of the design study addressed the second research question: What relationship exists amongst the three SC constructs, CogSC, RelSC, and StrSC? The researcher computed the scores on the 3 constructs based on the first unrotated factor score weightings of the LO scales theorized to be associated with each of the SC constructs and then computed their correlations. A Pearson Product Moment Correlation is used to reflect the degree in which the variables are related. The score ranges from +1 to -1. The correlation of 1.0 means there is a perfect positive linear relationship between the two variables. These correlations can be found in Table 10.

Table 10

### *Correlations Among the Three SC Constructs*

SC Constructs	Structural Capital	Cognitive Capital	Relational Capital
Structural Capital	1	.843(**)	.667(**)
Cognitive Capital	.843(**)	1	.820(**)
Relational Capital	.667(**)	.820(**)	1

*Note:* \*\* Correlation is significant at the 0.01 level (2-tailed).

Pearson Correlation showed significant interrelationships among StrSC and CogSC ( $r = .843$ ); StrSC and RelSC ( $r = .667$ ); CogSC and RelSC ( $r = .820$ ).

The data analysis revealed linear relationships ranging from ( $r = .667$ ), a moderate positive association, to ( $r = .843$ ) signifying a strong positive association.

#### *Fourth Phase of the Statistical Analysis*

The fourth phase of the design study addressed research question number three: Do the measures of the three Social Capital Constructs, individually and collectively, explain a significant proportion of variance in the satisfaction responses of middle school teachers? The third research question was addressed by regressing the measure of JS on the measures of the three Social Capital constructs. Using a principal component analysis the three SC construct measures were constructed by separately factoring the four scales or (manifest variables) assigned to each of the three SC constructs, then saving the factor score on the first unrotated component in each case. JS was measured with only one survey item, which minimizes the potential reliability with which this construct was measured. However, this construct has a long history of being measured by single items, and there is no reason to believe that the resulting scores do not meet at least minimum standards of reliability and construct validity (Wanous, Reichers, & Hudy, 1997). The four measures utilized in addressing this question were evaluated for their conformance to the assumption of normality of their distributions. In all four cases their skewness and kurtosis indexes fell between  $\pm 1.0$ , which was well within the range of  $\pm 3.2$  index units conventionally accepted as the outer limits of conformance to normality.

A stepwise multiple regression was performed to determine the individual and collective degree to which the three SC variables could account for the variance in job satisfaction. The results of this analysis are presented in Table 11.



Table 11

*Results of Regression of Job Satisfaction on the Three Social Capital Variables*

Independent Variable	Added at Step:	b <sup>a</sup>	SE b	β	Sig. of b	Adj. R <sup>2</sup> at step:	Sig. of change
Cognitive Capital	1	.321	.156	.210	.040	.100	<.001
Relational Capital	2	.241	.111	.162	.030	.108	.026
Structural Capital	3	-.035	.115	.023	.763	.106	.763

Note: <sup>a</sup> Constant = 4.469

Only two of the three SC variables, Cognitive Capital and Relational Capital, accounted for significant portions of variance in JS among teachers. Although Structural Capital had a significant zero-order correlation with JS ( $r = .247, p < .01$ ), Cognitive and Relational Capital had even higher zero-order correlations with JS. After they had been included in the regression equation, their relatively high overlap with Structural Capital (together they accounted for 67% of Structural Capital variance) meant that any incremental contribution of Structural Capital was negligible.

Considering the regression with just the two useful predictors, they accounted for 10.8% of the variance in JS. While this degree of explanation is significant, it leaves a lot of the variance in JS subject to explanation by other factors.

*Fifth Phase of the Statistical Analysis*

The fifth and final phase of the design study focused on testing the fourth research question: will there be at least a minimally acceptable degree of fit between the observed covariance matrix and the covariance matrix produced by the conceptual model? The question was addressed by conducting a test of the fit of the structural equation model to the data. The model is presented in Figure 5.

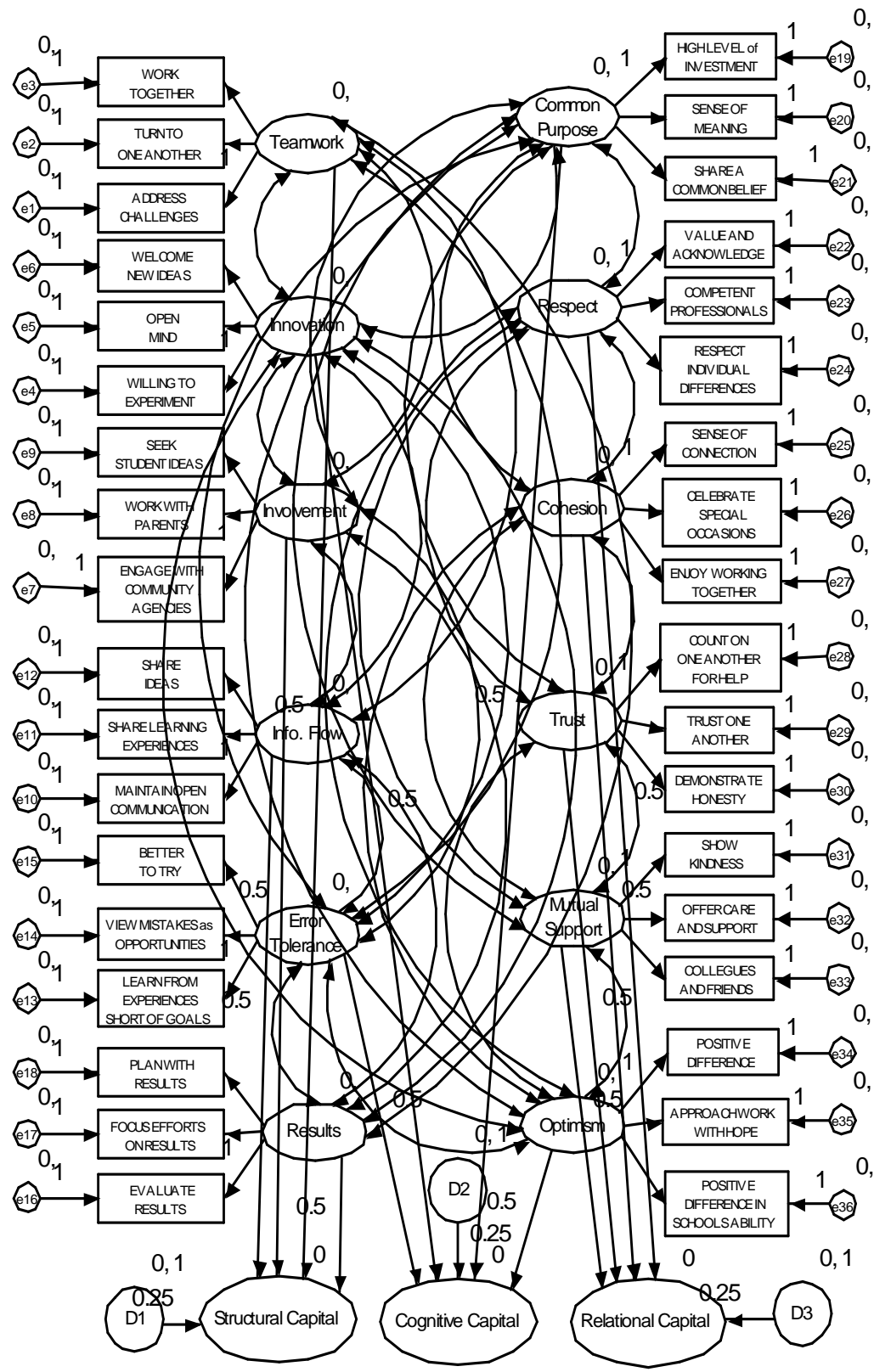

Figure 5. Complete Structural Equation Model.

The complete structural equation model in Figure 5 illustrates the relationship between the 36 items and the 12 LO dimensions and the 12 LO dimensions and the three SC constructs; StrSC, CogSC, and RelSC. The results of the analysis of the full SEM model are presented in Table 12.

Table 12

*Results of the Analysis of the Full SEM Model.*

Measure of Fit	Value
1. Chi-square test of minimum sample discrepancy:	
Chi-square	2725.565
p-value (df)	<.001 (df=559)
Chi-square/df	4.876
2. Incremental Fit Index	.912
3. Tucker Lewis Index	.900
4. Comparative Fit Index	.911
5. Root Mean Squared Error of Approximation	.071
90% confidence interval:	.069 - .074

The results presented in Table 12 indicate that there was an acceptable level of fit in the data between the theorized associations of the 36 manifest variables, the 12 LO scales (dimensions), and the three SC constructs. The chi-square test for minimum sample discrepancy was highly significant, but its  $\chi^2/df$  ratio was less than the upper limit of acceptability (5.0). As previously explained, the chi-square test is widely recognized as the most problematic of all the conventionally-used fit measures due to the excessive ease with which it rejects the null hypothesis. It is sensitive to sample size, particularly to the

ratio between sample size and the degrees of freedom. As the latter ratio increases, it becomes increasingly difficult to retain the null hypothesis. Thus, in this case where the ratio is very high (i.e., 14), its indication of a high discrepancy between the predicted and observed covariance matrix should be given less weight in judging the fit than that given to more refined indexes which are less susceptible to this rejection bias. The results for the more refined fit indexes, IFI, TLI, and CFI, are presented in subsequent rows of Table 12. The values for these indexes are .912, .900, and .911, respectively. All of these exceed the conventional standard for acceptable fit of .90. The model also met the standard for acceptability on the RMSEA criterion (i.e.,  $\leq .08$ ).

*First Phase Results: Exploratory Factor Analysis*

The initial analysis sought to ascertain whether there was an acceptable degree of fit between the 12 LO constructs and the three variables used to measure each of these constructs. The Confirmatory Factor Analysis (CFA) conducted to make the aforementioned determination produced evidence of an acceptable degree of fit. Although the chi-square test of minimum sample discrepancy was significant ( $\chi^2 = 2728.891$ ,  $p < .001$ ,  $df = 564$ ), the chi-square/df ratio of 4.838 was below the maximum acceptable value of 5.0. The fit indexes equaled or exceeded the conventional standard of .90 for acceptable fit (IFI = .912, TLI = .901, CFI = .911), and the RMSEA of .071 fell below the conventional upper limit of acceptable fit of .08. The theorized association between the 36 items and the 12 LO constructs (dimensions) fit the data analysis to an acceptable degree, thereby supporting Dr. Bowen's statistical results.

### *Second Phase Results: Confirmatory Factor Analysis*

Given that there was acceptable degree of fit between the theorized and observed relationships between the 36 LO items and 12 LO dimensions, an effort was made to answer the study's first research question concerning whether the data supported the theorized associations between the 12 LO dimensions and the 3 SC constructs. To answer this question, another confirmatory factor analysis was performed, this time using the scale scores on the 12 LO dimensions as the manifest indicators and the 3 SC constructs as the endogenous variables. Again, the CFA conducted to make the aforementioned determination produced evidence of an acceptable degree of fit. This time the chi-square test of minimum sample discrepancy was not only significant ( $\chi^2 = 700.495$ ,  $p < .001$ ,  $df = 564$ ), but its ratio to the degrees of freedom (i.e., chi-square/df) of 14.010 exceeded the maximum acceptable value of 5.0. However, the fit indexes equaled or exceeded the conventional standard of .90 for acceptable fit (IFI = .940, TLI = .920, CFI = .940). The RMSEA of .131 fell well above the conventional upper limit of acceptable fit of .08. Given these mixed results, we must conclude that there is only a marginally acceptable degree of fit between the theorized and observed associations between the LO dimensions and the SC constructs.

### *Third Phase Result: Research Question 2*

The second research question inquired as to the nature of the relationship(s) among the three SC constructs, CogSC, RelSC, and StrSC. To examine the relationships of the three SC constructs, the three SC constructs were given a factor score using the weights of the LO scales gathered from the EFA which then compute their correlations. Using the total number of participants ( $N = 761$ ), a Pearson Product Moment Correlation

(r) was used to reflect the degree in which the variables are related. The (r) score ranges from +1 to -1. The correlation of  $r = 1.0$  means there is a perfect positive linear relationship between the two variables. The Pearson Correlation showed significant interrelationships among StrSC and CogSC ( $r = .843$ ); StrSC and RelSC ( $r = .667$ ); CogSC and RelSC ( $r = .820$ ). The data analysis revealed positive linear relationships ranging from moderate ( $r = .667$ ), to strong ( $r = .843$ ). Given the results of the Pearson Correlation on the three SC constructs, the researcher examined to discover what relationship exists between the three SC constructs and the dependent variable, JS.

#### *Fourth Phase Results: Research Question 3*

A stepwise multiple regression was performed to determine the individual and collective degree to which the three SC variables could account for the variance in JS. Using a principal component analysis, the three SC construct measures were constructed by separately factoring the four scales or (manifest variables) assigned to each of the three SC constructs, then saving the factor score on the first unrotated component in each case. JS was measured by one survey item, one of eight questions on the SSP-LO measurement instrument, which allows a minimal potential reliability with which this construct was measured, as a continuous variable. The four scales or manifest variables assigned to each of the 12 LO were utilized and evaluated for their conformance to the assumption of normality of their distributions. In all four cases, their skewness and kurtosis indexes fell between  $\pm 1.0$ , which was well within the range of  $\pm 3.2$  index units conventionally accepted as the outer limits of conformance to normality.

*Fifth Phase Results: Confirming the Observed Covariance Matrix and the Covariance Matrix*

The final question for this study was: will there be at least a minimally acceptable degree of fit between the observed covariance matrix and the covariance matrix produced by the conceptual model? This question was addressed by conducting a test of the fit of the full structural equation model to the data. There was an acceptable level of fit in the data between the theorized associations of the 36 items (manifest variables), the 12 LO scales (dimensions), and the 3 SC constructs. The chi-square test for minimum sample discrepancy was highly significant, but its  $\chi^2/df$  ratio was less than the expected value for chi-square. However, the chi-square test is widely recognized as the most problematic of all the conventionally-used fit measures. It is sensitive to sample size and particularly to the ratio between sample size and the degrees of freedom. As the latter ratio increases, it becomes increasingly difficult to retain the null hypothesis. Thus, in this case where the ratio is very high (i.e., 14), its indication of a high discrepancy between the predicted and observed covariance matrix should be regarded lightly. The results for the more refined fit indexes, IFI, TLI, and CFI, are in Figure 5 of the dissertation and presented in subsequent rows in Table 12. The values for these indexes are .912, .900, and .911, respectively. All of these exceed the conventional standard for acceptable fit of .90. The model also met the standard for acceptability on the RMSEA criterion (i.e.,  $\leq .08$ ).

## Chapter 5: Dissertation Summary and Discussions

### *Introduction*

This study investigated the relationship between SC and teacher JS in 11 middle schools located in the urban and rural areas of Southeastern North Carolina. The conceptual basis for this study was a theoretical model that combined two theories, the Learning Organization theory and the Social Capital theory. The purpose of this study was two-fold: first, to determine whether there is at least a minimally acceptable degree of fit between the theorized and observed relationships of the manifest indicators with the LO dimensions and of the LO dimensions with the SC dimensions and second, to examine the relationship between the SC dimensions and teacher JS. The data used for the study was collected in a 2004-2005.

### *Problem Statement*

As mentioned before, according to Hargreaves (2001), school environments characterized by coworker relationships that lack trust, respect, and cohesion are likely to have adverse consequences for the work performance of teachers working in such environments. This study views these aspects of organizational environment as reflecting the Relational Social Capital (RelSC) construct of the theoretical model. Violations of the norms and values of working relationships have negative impacts on the LO. One of these impacts is the limitation or reduction of the quality of information flow and knowledge shared among teachers. According to Hargreaves (2001), this limits a school's ability to effectively increase student achievement. Information flow is one of the factors associated with the second SC construct, Structural Social Capital (StrSC), and is directly associated with how information and knowledge is transferred among its members.



Negative working relationships can adversely influence the school's organizational decision-making ability to achieve selected goals/outcomes and thereby can disrupt the cohesion and collective agreement needed to accomplish the shared vision for the school. Negative working relationships within a LO have negative consequences, which present distractions from what is important, disrupt information flow, and diminish the organization's ability to achieve its mission. For the purpose of the study, the RelSC construct consisted of four factors: respect, cohesion, trust, and mutual support, which teachers experience through their interactions with their coworkers. Information flow is one of the factors associated with the second SC construct, Structural Social Capital (StrSC), and is directly associated with how information and knowledge is transferred among its members and is associated with administrators as an important factor in JS. The third SC construct, Cognitive Social Capital (CogSC) is associated with teacher feelings and actions, which can be observed through the degree of common purpose with which tasks are approached and the optimism that propels teachers to achieve their selected goals. CogSC, according to research findings, was a dominate factor in its relationship to teacher JS. Thus, as previously mentioned, The National Center of Education Statistics (1997) reported "that when teachers perceive a lack of support for their work, they are not motivated to do their best in the classroom, and that when teachers are not satisfied with their working conditions; they are more likely to change schools or leave the profession" (p. 3).

Researchers Toremén and Karakus (2007) studied obstacles that decrease synergy in schools. The Toremén and Karakus study revealed that schools could achieve more if they worked collectively, focused on open communication among teachers, held stronger

collegial norms that were accepted by the school culture, worked in teams that were without structured inequalities, were inclined to work together collectively, and behaved “empathically and altruistically” (p. 642). The work of Bowen and Powers (2007), Hargreaves (2001), Toremén and Karakus, and others share the conception of a LO as being composed of individuals in a social setting who are responsible for achieving various organizational outcomes. However, the lack of SC within the LO limits, restricts, and diminishes the organization’s ability to reach the goals/outcomes to which it aspires.

### *Summary of Findings*

The researcher used the SC constructs to form a conceptual bridge between the LO concept and JS among teachers. As a first step in examining the validity of this model, the researcher used Confirmatory Factor Analysis (CFA) to examine the fit between Bowen’s 12 LO dimensions and their theorized manifest indicators, as operationalized in Bowen’s Student Success Profile-Learning Organization (Bowen et al., 2006). This analysis yielded the conclusion that an acceptable degree of fit existed between the observed and theorized relationships between the LO dimensions and their manifest indicators. The researcher then used CFA to examine the theorized versus observed relationships between the scored LO dimensions (justified on the basis of the initial CFA) and the three SC constructs. Upon confirming that an acceptable degree of fit existed between the theorized and observed LO-SC relationships, the researcher proceeded to determine the degree to which the three SC constructs accounted for the variance in teacher JS, using ordinary least squares multiple regression. This resulted in the finding that two of the three SC constructs (viz., Cognitive Social Capital and

Relational Social Capital) accounted for significant portions of the variance in teacher JS, combining to account for 10.8% of JS variance.

#### *Examination of Literature Review in Relation to Dissertation Findings*

The results of the study showed that teacher JS was primarily linked to CogSC, which accounted for 10.1% of the variance. This finding suggests that teachers associate JS within a school with a sense of optimism and common purpose among their colleagues, as well as with being able to act through innovative means with a degree of tolerance for error. What this study provided is a structured concept sequence linking the LO to three SC constructs encompassed by the theory of SC. This extends existing findings in literature regarding the relationship between organizational and social theories.

In communications with Dr. Bowen, he used the term *collective synergy* to describe how a school's staff needs to respond as an organization in its effort to effectively communicate, share knowledge, and work toward a perceived goal or accomplish a set task. A school's ability to share, exchange, and transfer knowledge is contingent upon the degree of mutual respect and trust among the school staff. This view is supported by Leana and Pil (2006) who characterized "the collective action of a group as a phenomenon of 'associability' or the willingness and ability to define collective goals that are then enacted collectively" (p. 354). This conceptual convergence leads to the inference that a school's organizational strength relies heavily on the stability and solidarity of teachers' work relationships and their ability to transfer information to achieve academic outcomes. Also, the collective unity of the staff assists the school's leadership team with informing community stakeholders, designing and planning the best

educational opportunities for students, and creating and developing an enriched work environment for teachers.

#### *Limitations of the Study*

For the purpose of preserving anonymity, demographic information such as gender, race, and age were not a part of this study. The preservation of anonymity allowed study participants to engage in a survey that contributes to educational research without the potential for any negative repercussions that may accompany candid answers. However, knowledge of participants' gender, age, years of actual experience within their school, and racial comparisons could have provided additional insight to the perceptions associated with Title I schools, which was the classification of all 11 schools used in this study. Title I schools tend to be characterized by a predominance of students in minority and lower socio-economic groups. Thus, one of the limitations associated with this study is that it does not address the issue of how the relationship between SC and teacher JS might differ between minority teachers and white non-Hispanic teachers. Among school administrators, JS was found to be associated to a significant degree only with the StrSC component. However, this finding was based on a low number of administrative participants ( $n = 34$ ). It would be desirable to ascertain whether this predominance of the influence of the structural component of SC would be reaffirmed in a larger sample.

#### *Theoretical and Practical Implications for Improving the Theoretical Model*

Structural equation modeling is an effective statistical procedure for testing models with strong theoretical and empirical support. The theoretical paths of the conceptual model are derived from two primary theories: LO theory and SC theory. Metaphorically, a LO is an organism that is in a constant state of motion moving toward

an outcome state, the favorability of which is determined by the human interactions within the social framework of an organization. The composite model that this study investigated provided insight into the manner in which the outcomes of one model (i.e., LO) are utilized as inputs to another model, SC, to produce an impact on an important individual outcome. Building on this theoretical model, it would be plausible for future researchers to study whether this composite model is useful for predicting other individual and organizational outcomes such as collective student performance (North Carolina ABC's model and AYP's), teacher retention, teacher performance, and student and staff attendance.

It would also be of interest to investigate the degree to which teacher JS moderates or mediates the relationship between student achievement and the SC constructs. Thus, a proposed research question would be: How much variance in student achievement is due to the influence of SC as mediated by teacher JS? Another useful direction of inquiry would be to examine the mediating and moderating effects of student readiness on the relationship between the SC constructs and teacher JS. Useful portions of variance in teacher JS may be accounted for by the degree to which students arrive at their perspective schools ill-prepared for learning, demonstrating a lack of motivation for learning, and socially at-risk.

Researchers are encouraged to test other facets of the theoretical model. Given the limited demographic information of the participants in this study, it would be desirable for a future study to acquire the necessary age, gender, years of teaching experience, and racial information required to identify any moderating effects of such variables. An indication of the potential relevance of such variables was this study's

finding that different SC constructs were predominant in accounting for JS among teachers with less than 1 year school tenure (ReISC predominant) and among teachers with 1 year or more of school tenure (CogSC predominant). More empirical findings are needed in this area to increase our ability to devise effective strategies for improving the effectiveness of the social interaction of LO members thereby enhancing outcomes for both teachers and students.

Bowen's SSP-LO measurement instrument poses two possibilities that may provide a basis for improving the theoretical model: the teacher's opinion of their school's organizational potential and actual school performance. Teacher views on these questions may account for additional variance in teacher JS. These variables could be used in either of two ways. First, they could be used as variables that moderate or mediate the impact of the SC constructs on teacher JS. Second, they could be used to form a more comprehensive measure of the favorability of teacher response to the work environment of the school such as JS.

#### *Practical Solutions to Promote the Increase of Social Capital Within Schools*

The theoretical model, the empirical findings, and the researcher's practical experiences working with Title I middle schools, provide the basis for proposing a practical solution to increase the level of SC within LOs. The solution requires the theoretical knowledge to be transferred to practical pursuits that are suitable for each school. It was found that administrators (viz., school principals) associated JS with StrSC, which encompasses the following factors: team orientation, stakeholder involvement, information flow, and results. In essence, StrSC measures the strength of working relationships and the knowledge transformed from those relationships. It would appear

that the status of the StrSC forms the basic framework within which the effects of CogSC and RelSC must occur, and that this is the primary domain affected by, and affecting, the principal. Consequently, it is necessary to start with the school principal and suggest the following ideas to increase the SC of each school and thereby achieve greater JS for teachers.

It is proposed that principals must institute certain organizational and personnel changes to foster and facilitate an optimally functioning learning community. In *Principal's Research Review: Supporting the Principal's Data Driven Decisions*, Susan Sather (2006) suggests that principals should address organizational improvements by the following actions:

- (a) Restructure the way teachers network or share information within the organization;
- (b) provide a structured format for teachers to collectively participate and collaborate within their department or grade level;
- (c) link or align professional developmental standards, assessments, and other school improvement efforts to create a sense of cohesion;
- (d) increase teacher content expertise;
- (e) create opportunities for teachers to review student work in efforts to engage teachers in reflection and error analysis of student work; and
- (f) ensure that teachers are able to meet on a regular basis. (p. 6)

When a principal institutes changes within the organization, social communication networks are impacted by the instituted changes. Principals who are effective leaders are aware of the positive or negative impacts such changes are likely to have on the school. They also need to be aware of the social and psychological implications of the changes and be prepared for the foreseeable reactions. For school

principals to develop and implement a professional learning community and effect change, principals must assess these specific elements: the culture of the school itself and the psychological maturity and personal characteristics of each of the employees. Quarterly school surveys need to be issued to school staff to assist with accurately detecting issues that detract and diminish the school's potential in order to address organization effectiveness. The principal may then draw upon this knowledge and intuitively know when to tell, sell, participate, or delegate responsibility to effectively address issues as they arise. Failure to take the necessary steps to accurately gauge the climate of the organization will result in ineffective leadership, which may lead to lower teacher morale and a decrease in JS.

The principal is directly responsible for assessing the academic needs of the students, providing evidence for organizational changes to address those academic needs, and finally, forecasting a vision for all stakeholders who will hopefully buy in, in order to create an educational environment conducive to the learning needs of students. Afterwards, the principal should be prepared to follow through by exercising both careful planning and implementation. Dufour, Dufour, and Eaker (2002) proposed several ways to develop and implement a school that is responsive to the needs of its students. First, Dufour et al. suggest the actions of a school's student body, faculty, and school leadership are indicators of the culture of the school. The school culture, whether positive or negative, shapes the minds of students. In addition, Dufour et al. suggest that providing a suitable learning culture for all students is important due to its direct impact on student achievement. In order to change or influence a learning culture, let us define what Dufour et al. consider a learning culture. They suggest that schools with a learning culture have



created an atmosphere where all participants of the organization are involved in the learning and educational process. In addition, they suggest “A professional learning culture needs to emphasize building communities with a specific focus on learning, collaboration, and results” (Dufour et al., p. 34). Notice, however, that Dufour, et al. broaden their definition of a learning culture to extend beyond the school walls in efforts to build communities that focus on learning, collaboration, and achievement. The primary focus for building a community of principals, teachers, and parents is student learning, collaboration of stakeholders, and student achievement. According to Dufour et al., leaders who focus on student learning need to ask and answer three questions:

Does every teacher know what students should learn and know after every lesson?

How does the school respond when students do not learn? What additional support systems are in place and are available to students who need extra time and support? (p. 12)

As stated previously, a learning culture focuses on building an environment that values the learning and the educational process. As an African proverb states, it takes a whole village to raise a child. The entire village is responsible for educating their children, and involvement is essential to the social and economic growth and development of that village. In modern terms, our schools are those villages. The analogy of the African proverb essentially expresses what Dufour and his colleagues are advocating in their efforts to build learning cultures in schools. Educating students requires a collective inquiry or joint venture of all participants responsible for student achievement. Reflection is both a powerful and effective strategy for teachers and administrators to help them discover the causes for students not learning and for school

districts not achieving the high academic standards required by the state. Dufour and Eaker (1998), authors of *Professional Learning Communities at Work: Best Practices for Enhancing Student Achievement*, provide principles and practical solutions for professional learning communities to assist educators in creating a systematic process to strategically assess and evaluate ways to improve student achievement.

*Conclusion: Implications for Future Research*

The results of this study were conclusive allowing the researcher to ascribe to possible future studies, suggestions, and discussions. The operational measurement of SC is a serious weakness of the SC theory. The literature is rife with inconsistent views about how to operationally define SC. Using Nahapiet and Ghoshal's (1998) three SC constructs, this research study provided justification for operationalizing the concept by linking the theory of SC to Dr. Bowen's concept of the LO. Both theories are well-established in the literature. Future research on SC in the area of education needs to account for those variables that are responsible for assisting and supporting school processes and school outcomes. The present research was able to provide empirical evidence that SC can be quantified, producing measures that account for significant portions of variance in a more distal outcome variable, teacher JS. This result makes a viable case for future studies to explore this theoretical framework through efforts to predict other LO outcomes such as teacher turnover and student achievement.

Over the last decade, scholars and researchers have explored and theorized about the concepts of learning organizations, social capital, intellectual capital, and human capital and are discovering the intricacies of each concept and their connections. This researcher sees this type of study as part of an ongoing endeavor to produce a diagnostic and prescriptive system

to help schools improve their preparation for incoming students, increase teacher effectiveness, and create a working atmosphere that generates a positive and enriching LO for students. The findings of this research raise further questions for exploration. For example, to what extent does JS mediate or moderate the influence of SC on student achievement? A question of this nature would allow the researcher to look at both the processes that contribute to teacher JS and how much variance in student achievement can be contributed to SC. This research is consequently offered as a theoretical and empirical foundation on which further studies can be conducted to identify the determinants of educational outcomes.

## References

- Adler, P. S., & Kwon, S. K. (2002). Social capital. Prospects for a new concept. *Academy of Management Review*, 27(1), 17-40.
- Armstrong, W. I. (2002). Leveraging intellectual capital: Visionary knowledge management. *School Business Administrator*, 68(7), 34-35.
- Aneshensel, C. S., & Sucoff, C. A., (1996). The neighborhood context of adolescent mental health. *Journal of Health and Social Behavior*, 37, 293-310.
- Bourdieu, P. (1986). The forms of capital. In J. Richardson (Ed.), *Handbook of theory and research for the sociology of education*. (pp. 241-58). New York: Greenwood.
- Bowen, G. L. (2009). Social organization and schools: A general systems theory perspective. In P. Allen-Meares (Ed.), *Social work services in schools* (6<sup>th</sup> ed.). (pp. 48-64). Boston: Pearson Education, Inc.
- Bowen, N. K., & Bowen, G. L. (1999). Effects of crime and violence in neighborhoods and schools on the school behavior and performance of adolescents. *Journal of Adolescent Research*, 14, 319-42.
- Bowen, G. L., & Powers, J. D. (2003). *The School Success Profile Learning Organization*. (SSP-LO). Chapel Hill, NC: Jordan Institute for Families, School of Social Work. The University of North Carolina at Chapel Hill. Jordan Institute for Families.
- Bowen, G. L., Ware, W. B., Rose, R. A., & Powers, J. D. (2007). Assessing the functioning of schools as learning organizations. *Children and Schools*, 29, 199-208.
- Bowen, G. L., Rose, R. A., & Ware, W. B. (2006). The reliability and validity of the school success profile learning organization measure. *Evaluation and Program Planning*, 29, 97-104.
- Brooks-Gunn, J., Duncan, G. J., Klebanov, P. K., & Sealand, N. (1993). Do neighborhoods affect child and adolescent development? *American Journal of Sociology*, 99, 353-95.
- Cors, R. (2003). *What is a learning organization? Reflections on literature and practitioner perspectives*. Wisconsin: Organizational Learning for Environment Management.
- Davis, J., & Wilson, S. M. (2000). Principal's efforts to empower teachers: Effects on teacher motivation and job satisfaction and stress. *The Clearing House Journal*, 73(6), 349-353.

- Dewey, E. A. (1991). *Basic applications of Adlerian Psychology for self-understanding and human relationships*. FL: Communication and Motivation Training Institute, Inc.
- Dufour, R., Dufour, R., & Eaker, R. (2002). *Getting started: Reculturing schools to become professional learning communities*. Indiana: National Education Service.
- Dufour, R., & Eaker, R. (1998). *Professional learning communities at work: Best practices for enhancing student achievement*. Indiana: Solution Tree.
- Easley, M. (2008). *Highlights from the 2008 teacher working conditions survey results*. Retrieved February 25, 2009, from [http://www.dpi.state.nc.us/sbe\\_meetings/0901/t](http://www.dpi.state.nc.us/sbe_meetings/0901/t)
- Ferguson, M. K. (2006). Social capital and children's wellbeing: A critical synthesis of the international social capital literature. *International Journal of Social Welfare*, 15, 2-18.
- Fitzpatrick, K. M., & Wright, D. R. (2006). Social capital and adolescent violent behavior: Correlates of fighting and weapon use among secondary students. *Social Forces*, 84(3), 1435-1453.
- Greene, J. P., & Forster, G. (2004, September). *The teachability index: Can disadvantage students learn?* Retrieved February 22, 2008, from [http://www.manhattan-institute.org/html/ewp\\_06.thm](http://www.manhattan-institute.org/html/ewp_06.thm)
- Grimes, C. F. (2006). *Employee motivation, the organizational environment and productivity*. Accel-Team. Retrieved November 22, 2008, from [http://www.accel-team.com/ltzpubz\\_h6mxA0806/at PDF\\_02\\_employeeMotivation.html](http://www.accel-team.com/ltzpubz_h6mxA0806/at PDF_02_employeeMotivation.html)
- Hamilton, C. V. (2007). *The surprising origins and meaning of the "pursuit of happiness."* Retrieved November 15, 2008, from <http://hnn.us/articles/46460.html>
- Hargreaves, D. H. (2001). A capital theory of school effectiveness and improvement. *British Educational Research Journal*, 27(4), 487-501.
- Hirsh, E., Emerick, S., Church, K., & Fuller, E. (2006). *A Report on the 2006 North Carolina Teacher Working Conditions Survey*. NC: Center for Teaching Quality.
- Hooper, A., & Holford, J. (1998). *Adler for beginners*. NY: Writers and Readers Publishing.
- Jones, G. M., Jones, B. D., Hardin, B., Chapman, L., Yarbrough, T., & Davis, M. (1999). Impact of high-stakes testing on teachers and students in North Carolina. *Phi Delta Kappan*, 81, 109-203.

- Kelly, A. (2004). The intellectual capital of schools: Analyzing government policy statements on school improvement in light of a new theorization. *Journal of Education Policy*, 19(5), 609-629.
- Kezar, A. (2005). What campuses need to know about organizational learning and the learning organization. *New Direction for Higher Education*, 131, 7-22.
- Kuusisto, R., Helokunnas, T., & Ahvenainen, S. (2003). Intellectual capital and time in information superiority. In Proc. Of the 2<sup>nd</sup> European Conference on Information Warfare and Security (pp. 201-210). Reading, UK
- Leana, C. R., & Van Buren III, H. J. (1999). Organizational social capital and employment practices. *Academy of Management Review*, 24(3), 538-555.
- Leana, C., & Pil, F. (2006). Social capital and organizational performance: Evidence from urban public schools. *Organization Science*, 17(3), 353-366.
- Lee, L. L. (2005). Social capital links between management decision-making, intellectual capital and market performance. *actKM Online Journal of Knowledge Management*, 1(1), 1-26.
- Madsen, S. R. (2001). Intellectual capital: Comparison and contrast. *Performance Improvement*, 40(4), 17-23.
- Nahapiet, J., & Ghoshal S. (1998). Social capital, intellectual capital, and the organizational advantage. *Academy of Management Review*, 23(2), 242-266.
- National Center for Education Statistics. (1997). *Job satisfaction among Americas' teachers: Effects of workplace conditions, background characteristics, and teacher compensation*. Retrieved November 22, 2008, from <http://nces.ed.gov/pubs97/97471.pdf>
- National School Boards Association. (2004). *Ensuring the goals of no child left behind. Recommendations for legislative and regulatory changes*. Retrieved July 25, 2009, from <http://www.nsba.org/docs/33100/33080.pdf>.
- No Child Left Behind Act, 20 U.S.C. & 6301 (2002).
- North Carolina School Report Cards. (2005-2006). *2005-2006 Data sources and information*. Retrieved July 25, 2007, from <http://www.ncreportcards.org/src/performance.jsp>
- North Carolina School Report Cards, (2007). Data sources and information-quality teachers and administrators. *Glossary of Terms*. Retrieved July 25, 2007, from <http://www.ncschoolreportcard.org/src/glossary.jsp>

- Pearson, C. L., & Moomaw, W. (2006). Continuing validation of the teaching autonomy scale. *Journal of Educational Research*, 100(1), 44-51.
- Portes, A. (1998). Social capital: Its origins and applications in modern sociology. *Annual Review of Sociology*, 24, 1-24.
- Pugh, D. S., & Hickson, D. J. (1997). *Writers on organizations* (5<sup>th</sup> ed.). California: Sage Publications.
- Putman, R. D. (2000). *Bowling alone: The collapse and revival of American community*. NY: Simon and Schuster.
- Resnick, M. D., Bearman, R. W., Blum, K. E., Bauman, K. M., Harris, J. J., Tabor, J., et al. (1997). Protecting adolescents from harm: Findings from The National Longitudinal Study of Adolescent Health. *Journal of the American Medical Association*, 278, 823-32.
- Sather, S. (2006). Principal's research review support the principal's data driven decisions. *National Association on Secondary School Principals*. 1(5), 1-7.
- Schein, E. H. (1985). *Organizational culture and leadership*. San Francisco: Jossey-Bass.
- Stoelting, R. (2002). *Structure equation modeling/path analysis*. Retrieved October 14, 2009, from <http://userwww.stsu.edu/~efe/classes/bio710/path/SEMwebpage.htm>.
- Subramaniam, M., & Youndt, M. A. (2005). The influence of intellectual capital on the types of innovative capabilities. *Academy of Management Journal*, 48(3), 450-463.
- Toremén, F., & Karakus, M. (2007, January). The obstacles of synergy in schools: A qualitative study on teamwork. *Educational Sciences Theory & Practice*, 7(1), 640-645.
- U.S. Department of Education. (2007). *Improving basic programs operated by local education agencies* (Title I, Part A). Retrieved April 13, 2007, from, <http://www.ed.gov/programs/titleiparta/index.html>
- Wanous, J. P., Reichers, A. E., & Hudy, M. J. (1997). Overall job satisfaction: How good are single item measures? *Journal of Applied Psychology*, 82(2), 247-252.

Appendix A

Permission to Use SSP-LO Data from 11 Middle Schools in NC



December 4, 2009

RE: Permission to Use SSP-LO Data from 11 Middle Schools in NC (see Bowen, Ware, Rose, and Powers, 2007 below for details of administration)

Name of Researcher: Timothy Lee Chazon

Dr. Gary L. Bowen gives permission to the above named researcher to use 2005 data from the School Success Profile Learning Organization (SSP-LO) for purposes of his dissertation in Educational Leadership at Gardner-Webb University. These data were collected under the auspices of the Behavioral Institutional Review Board at the University of North Carolina at Chapel Hill. The names of the actual schools that participated in the study will not be identified under any circumstances. These schools will be identified in presentations and publications as 11 public middle schools (grades 6<sup>th</sup>-8<sup>th</sup>) that were located in two geographically adjacent school districts in North Carolina: one in a rural community and the other in an urban area.

For purposes of general citation, please use the following reference when referring to the SSP-LO survey:

Bowen, G. L., & Powers, J. D. (2003). *The School Success Profile Learning Organization (SSP-LO)*. Chapel Hill, NC: Jordan Institute for Families, School of Social Work, The University of North Carolina at Chapel Hill.

When referencing prior studies with these data, please use the following reference:

Bowen, G. L., Ware, W. B., Rose, R. A., & Powers, J. D. (2007). Assessing the functioning of schools as learning organizations. *Children & Schools*, 29, 199-208.

I would appreciate receiving an electronic copy (PDF) of publications that result from your use of these data, including your dissertation. I also request permission to cite your publications on the SSP-related publication listings, such as the SSP Website @ [schoolsucceessprofile.org](http://schoolsucceessprofile.org).

Please send me a letter or email that acknowledges that you agree with above terms.

Thank you.

Gary L. Bowen, Ph.D., ACSW

Appendix B

The School Success Profile-Learning Organization (SSP-LO)





26674

# School Success Profile

## Learning Organization

SSP - 20

### Instructions

- Read each question carefully.
- Use a Number 2 lead pencil. 
- Fill in the oval that matches your answer like this:  NOT like this: 
- Erase completely any answer you wish to change.

*Jordan Institute for Families*

University of North Carolina at Chapel Hill, School of Social Work





26674

## Introduction

### What is the School Success Profile Learning Organization (SSP-LO)?

The SSP-LO includes 36 items that examine your beliefs about your school as a learning organization. The SSP-LO also includes items that assess your overall state of health, as well as your level of job satisfaction, perceived control over results at this school, plans to continue your career at this school, and the performance of this school in addressing the learning needs of students.

### Who is conducting this survey?

Dr. Gary L. Bowen, Kenan Distinguished Professor and Director of the School Success Profile Project, School of Social Work, The University of North Carolina at Chapel Hill, is coordinating the administration of the SSP-LO at your school. Your school sponsored your participation in this survey.

### What do you want me to do?

We would like you to complete the SSP-LO. It should take you no more than 15 minutes to complete. This is not a test. There are no right or wrong answers. Please try to answer every question.

### Must I participate?

No. Your participation is voluntary. However, we encourage your participation. Your views and opinions are very important to providing an accurate profile of employees at your school.

### Who will see my answers?

Only the project staff at The University of North Carolina at Chapel Hill will see your survey answers. Summary subgroup breakdowns (e.g., current position) will include at least ten or more respondents.

### Will you know who I am?

No. Your answers on this survey are anonymous. No identifiers are included on the survey.

### Are there any special instructions?

It is important that you follow the directions for each question. Please indicate your answer to each question by marking the response that best represents your answer. You may change your response by erasing your answer and selecting one of the other choices. Please answer the questions in the order they are presented.

*Thank You!*

Developed by Dr. Gary L. Bowen and Joelle D. Powers, Jordan Institute for Families, School of Social Work, The University of North Carolina at Chapel Hill.

Copyright 2003 by the School of Social Work, The University of North Carolina at Chapel Hill. All rights reserved. No portion of the School Success Profile Learning Organization (SSP-LO) may be reproduced or utilized in any form or by any means without written permission from Dr. Gary L. Bowen. To contact him, call (919) 962-6542, or write to him care of the School of Social Work, The University of North Carolina at Chapel Hill, Chapel Hill, NC 27599-3550. He may also be reached by email at [glbowen@email.unc.edu](mailto:glbowen@email.unc.edu).



26674

## Learning Organization Profile

1. The Learning Organization Profile lists 36 descriptive characteristics of schools. Please indicate the extent to which you agree (strongly disagree to strongly agree) that each characteristic is descriptive of the school at which you are employed. For purposes of responding, "we" refers to all adult employees at this school.

At my school, we:	STRONGLY DISAGREE	DISAGREE	SLIGHTLY DISAGREE	SLIGHTLY AGREE	AGREE	STRONGLY AGREE
a. Work together as a team.	<input type="radio"/>	<input type="radio"/>	<input type="radio"/>	<input type="radio"/>	<input type="radio"/>	<input type="radio"/>
b. Welcome and appreciate new ideas.	<input type="radio"/>	<input type="radio"/>	<input type="radio"/>	<input type="radio"/>	<input type="radio"/>	<input type="radio"/>
c. Seek ideas and opinions from students.	<input type="radio"/>	<input type="radio"/>	<input type="radio"/>	<input type="radio"/>	<input type="radio"/>	<input type="radio"/>
d. Share ideas and information with one another about how to make this school more effective.	<input type="radio"/>	<input type="radio"/>	<input type="radio"/>	<input type="radio"/>	<input type="radio"/>	<input type="radio"/>
e. Agree that it is better to try new things and risk failure than not to try at all.	<input type="radio"/>	<input type="radio"/>	<input type="radio"/>	<input type="radio"/>	<input type="radio"/>	<input type="radio"/>
f. Plan with intended results in mind.	<input type="radio"/>	<input type="radio"/>	<input type="radio"/>	<input type="radio"/>	<input type="radio"/>	<input type="radio"/>
g. Turn to one another for consultation and advice.	<input type="radio"/>	<input type="radio"/>	<input type="radio"/>	<input type="radio"/>	<input type="radio"/>	<input type="radio"/>
h. Keep an open mind about new ways of doing things.	<input type="radio"/>	<input type="radio"/>	<input type="radio"/>	<input type="radio"/>	<input type="radio"/>	<input type="radio"/>
i. Work with parents as partners in the educational process.	<input type="radio"/>	<input type="radio"/>	<input type="radio"/>	<input type="radio"/>	<input type="radio"/>	<input type="radio"/>
j. Feel comfortable sharing our learning experiences with one another.	<input type="radio"/>	<input type="radio"/>	<input type="radio"/>	<input type="radio"/>	<input type="radio"/>	<input type="radio"/>
k. View mistakes as opportunities for learning.	<input type="radio"/>	<input type="radio"/>	<input type="radio"/>	<input type="radio"/>	<input type="radio"/>	<input type="radio"/>
l. Focus our efforts on achieving measurable results.	<input type="radio"/>	<input type="radio"/>	<input type="radio"/>	<input type="radio"/>	<input type="radio"/>	<input type="radio"/>
m. Meet together to address challenges and solve problems.	<input type="radio"/>	<input type="radio"/>	<input type="radio"/>	<input type="radio"/>	<input type="radio"/>	<input type="radio"/>
n. Are willing to experiment with new practices.	<input type="radio"/>	<input type="radio"/>	<input type="radio"/>	<input type="radio"/>	<input type="radio"/>	<input type="radio"/>
o. Engage and collaborate with community agencies and organizations.	<input type="radio"/>	<input type="radio"/>	<input type="radio"/>	<input type="radio"/>	<input type="radio"/>	<input type="radio"/>
p. Maintain open lines of communication.	<input type="radio"/>	<input type="radio"/>	<input type="radio"/>	<input type="radio"/>	<input type="radio"/>	<input type="radio"/>
q. Learn from those experiences where our results fall short of defined goals.	<input type="radio"/>	<input type="radio"/>	<input type="radio"/>	<input type="radio"/>	<input type="radio"/>	<input type="radio"/>
r. Evaluate results against previously defined goals.	<input type="radio"/>	<input type="radio"/>	<input type="radio"/>	<input type="radio"/>	<input type="radio"/>	<input type="radio"/>



26674

## Learning Organization Profile

At my school, we:	STRONGLY DISAGREE	DISAGREE	SLIGHTLY DISAGREE	SLIGHTLY AGREE	AGREE	STRONGLY AGREE
s. Share a high level of investment in what we are here to do.	<input type="radio"/>	<input type="radio"/>	<input type="radio"/>	<input type="radio"/>	<input type="radio"/>	<input type="radio"/>
t. Value and acknowledge one another as individuals.	<input type="radio"/>	<input type="radio"/>	<input type="radio"/>	<input type="radio"/>	<input type="radio"/>	<input type="radio"/>
u. Feel a sense of connection and loyalty to one another.	<input type="radio"/>	<input type="radio"/>	<input type="radio"/>	<input type="radio"/>	<input type="radio"/>	<input type="radio"/>
v. Can count on one another for help and support.	<input type="radio"/>	<input type="radio"/>	<input type="radio"/>	<input type="radio"/>	<input type="radio"/>	<input type="radio"/>
w. Show kindness and thoughtfulness to one another.	<input type="radio"/>	<input type="radio"/>	<input type="radio"/>	<input type="radio"/>	<input type="radio"/>	<input type="radio"/>
x. Feel confident that we can make a positive difference in students' lives.	<input type="radio"/>	<input type="radio"/>	<input type="radio"/>	<input type="radio"/>	<input type="radio"/>	<input type="radio"/>
y. Feel a strong sense of meaning and purpose in our work.	<input type="radio"/>	<input type="radio"/>	<input type="radio"/>	<input type="radio"/>	<input type="radio"/>	<input type="radio"/>
z. Treat one another as competent professionals.	<input type="radio"/>	<input type="radio"/>	<input type="radio"/>	<input type="radio"/>	<input type="radio"/>	<input type="radio"/>
aa. Celebrate special occasions, accomplishments, and milestones.	<input type="radio"/>	<input type="radio"/>	<input type="radio"/>	<input type="radio"/>	<input type="radio"/>	<input type="radio"/>
bb. Trust one another.	<input type="radio"/>	<input type="radio"/>	<input type="radio"/>	<input type="radio"/>	<input type="radio"/>	<input type="radio"/>
cc. Offer care and support for one another in times of personal and family need.	<input type="radio"/>	<input type="radio"/>	<input type="radio"/>	<input type="radio"/>	<input type="radio"/>	<input type="radio"/>
dd. Approach our work with hopefulness and optimism.	<input type="radio"/>	<input type="radio"/>	<input type="radio"/>	<input type="radio"/>	<input type="radio"/>	<input type="radio"/>
ee. Share a common belief in the importance of our work.	<input type="radio"/>	<input type="radio"/>	<input type="radio"/>	<input type="radio"/>	<input type="radio"/>	<input type="radio"/>
ff. Respect and appreciate individual differences.	<input type="radio"/>	<input type="radio"/>	<input type="radio"/>	<input type="radio"/>	<input type="radio"/>	<input type="radio"/>
gg. Enjoy working together.	<input type="radio"/>	<input type="radio"/>	<input type="radio"/>	<input type="radio"/>	<input type="radio"/>	<input type="radio"/>
hh. Demonstrate honesty and personal integrity in our work together.	<input type="radio"/>	<input type="radio"/>	<input type="radio"/>	<input type="radio"/>	<input type="radio"/>	<input type="radio"/>
ii. Treat one another as both colleagues and friends.	<input type="radio"/>	<input type="radio"/>	<input type="radio"/>	<input type="radio"/>	<input type="radio"/>	<input type="radio"/>
jj. Believe we can make a positive difference in this school's ability to meet its performance goals.	<input type="radio"/>	<input type="radio"/>	<input type="radio"/>	<input type="radio"/>	<input type="radio"/>	<input type="radio"/>





26674

## PERSONAL AND SCHOOL OUTCOME PROFILE

2. How would you describe your overall state of health these days?
- Excellent
  - Very Good
  - Good
  - Fair
  - Poor
  - Extremely Poor
3. Overall, how satisfied are you with your job at this school?
- Very Satisfied
  - Satisfied
  - Slightly Satisfied
  - Slightly Dissatisfied
  - Dissatisfied
  - Very Dissatisfied
4. Please indicate your level of agreement with the following statement: *I can make a positive difference in the ability of this school to meet its performance objectives for students.*
- Strongly Agree
  - Agree
  - Slightly Agree
  - Slightly Disagree
  - Disagree
  - Strongly Disagree
5. How likely are you to continue your employment at the school for another academic year?
- Does not apply; I will retire at the end of this academic year or I am a temporary employee.
  - (0 in 10) No Chance
  - (1 in 10) Very Slight Chance
  - (2 in 10) Slight Possibility
  - (3 in 10) Some Possibility
  - (4 in 10) Fair Possibility
  - (5 in 10) Fairly Good Possibility
  - (6 in 10) Good Possibility
  - (7 in 10) Probable
  - (8 in 10) Very Probable
  - (9 in 10) Almost Sure
  - (10 in 10) Certain
6. What grade would you assign to the performance of your school in addressing the educational needs of all students?
- A Well Above Average
  - B Above Average
  - C Average
  - D Below Average
  - F Well Below Average
7. What grade would you assign to the potential of your school for addressing the educational needs of all students?
- A Well Above Average
  - B Above Average
  - C Average
  - D Below Average
  - F Well Below Average

### ABOUT YOU

8. My current position is best described as:
- Administrator
  - Specialist (e.g., counselor, psychologist)
  - Teacher
  - Teacher Assistant
  - Other Employee
9. How many years have you been assigned to this school?
- Less than one year
  - One year or more

### THANK YOU!

WE LOOK FORWARD TO SHARING THE RESULTS OF THIS SURVEY WITH YOU.

## Appendix C

### School Success Profile-Learning Organization Dimensions



## School Success Profile-Learning Organization Dimensions

### Actions

**Team Orientation:** Employees work together as a team, turn to one another for consultation and advice, and meet together to address challenges and solve problems.

**Innovation:** Employees welcome and appreciate new ideas, keep an open mind about new ways of doing things, and are willing to experiment with new practices.

**Involvement:** Employees seek ideas and opinions from students, work with parents as partners in the educational process, and engage and collaborate with community agencies and organizations.

**Information Flow:** Employees share ideas and information with one another about how to make this school more effective, feel comfortable sharing their learning experiences with one another, and maintain open lines of communication.

**Tolerance for Error:** Employees agree that it is better to try new things and risk failure than not to try at all, view mistakes as opportunities for learning, and learn from those experiences where their results fall short of defined goals.

**Results Orientation:** Employees plan with the intended results in mind, focus their efforts on achieving measurable results, and evaluate results against previously defined goals.

### Sentiments

**Common Purpose:** Employees share a high level of investment in what they are here to do, feel a strong sense of meaning and purpose in their work, and share a common belief in the importance of their work.

**Respect:** Employees value and acknowledge one another as individuals, treat one

another as competent professionals, and respect and appreciate individual differences.

Cohesion: Employees feel a sense of connection and loyalty to one another; celebrate special occasions, accomplishments, and milestones; and enjoy working together.

Trust: Employees can count on one another for help and support, trust one another, and demonstrate honesty and personal integrity in their work together.

Mutual Support: Employees show kindness and thoughtfulness to one another, offer care and support for one another in times of personal and family need, and treat one another as both colleagues and friends.

Optimism: Employees feel confident that they can make a positive difference in students' lives, approach their work with hopefulness and optimism, and believe they can make a positive difference in this school's ability to meet its performance goals.