

A comparative investigation of the wear characteristics of a high power diode laser generated single-stage tile grout and commercial epoxy tile grout

J. Lawrence*, L. Li*, R.E. Edwards** and A.G. Gale**

*Laser Processing Research Centre, Department of Mechanical, Aerospace and Manufacturing Engineering, ** Department of Civil and Construction Engineering, University of Manchester Institute of Science and Technology (UMIST), Manchester, M60 1QD, UK.

Correspondence

Dr. Jonathan Lawrence
Manufacturing Engineering Division,
School of Mechanical & Production Engineering,
Nanyang Technological University (NTU),
Nanyang Avenue,
Singapore 639798.

Tel : (65) 790 5542

Fax : (65) 791 1859

email : mjlawrence@ntu.edu.sg

Abstract

A comparative study of a single-stage ceramic tile grout, generated using a 60 W high power diode laser (HPDL), and a commercially available tile grout has determined the wear characteristics of the two materials. Within both normal and corrosive environmental conditions, the single-stage ceramic tile grout proved to have a superior wear rate over the epoxy tile grout, 0.9 mg/cm²/h compared with 125 mg/cm²/h when in an HNO₃ environment respectively. Likewise, life assessment testing revealed that the single-stage ceramic tile grout gave an increase in wear life of 4 to 42 times over the commercially available epoxy tile grout, depending upon the corrosive environment. It is believed that the economic and material benefits to be gained from the deployment of such an effective and efficient means of sealing ceramic tiles could be significant.

Keywords: High power diode laser (HPDL); Epoxy tile grout; Single-stage seal; Surface glazing; Wear; Life characteristics

1. Introduction

Currently, the most intractable problem with ceramic tiled surfaces is that contaminants can enter into, and exit a space via the grout used to fill the void between adjoining ceramic tiles. This problem is further compounded by the fact that the wear characteristics of commercially available epoxy tile grouts are poor. Consequently, routine cleaning of the tiled surface with detergents and other cleaning agents brings about a significant reduction in the life of the epoxy tile grout. What is more, because commercially available epoxy tile grouts are very difficult to clean and wear easily as a result of cleaning, they become contaminated over time and have to be removed physically or mechanically, both of which are arduous and costly undertakings.

To counter these problems inherent to commercially available epoxy tile grout, a new approach was created by Lawrence and Li [1, 2]. This new approach was not only comprised of the development of a new grout material termed the amalgamated oxide compound grout (AOCG), but also a new grouting technique whereby a high power diode laser (HPDL) was used to glaze an enamel coating on the surface of the AOCG, thus resulting in a two-stage sealing process. This technique has been developed further by Lawrence et al. [3], resulting in the development of a single-stage sealing process using the HPDL. The new grouting material used crushed vitrified ceramic tiles as a bulk filler with an enamel frit placed directly on top. In this way a single-stage process could be achieved as theoretically the materials could be applied in a single action and only one pass of the HPDL would be required. The seals generated between adjoining vitrified ceramic tiles with the single-stage grout were found to be tough and inexpensive, as well as providing an amorphous, crack-free surface glaze. In this way the tiles were sealed together permanently, preventing any further contamination activity; in effect creating a completely sealed surface that is both impermeable and relatively simple to clean and maintain since contaminants are basically arrested on the surface of the tile and the glazed seal. Because such a seal would be an integral part of the surface as the tiles themselves, the necessity to remove old or contaminated grout from the void between the tiles would be eliminated.

The current literature abounds with reports on the surface treatment of metals using lasers for the purposes of enhancing wear characteristics. A number of workers have successfully demonstrated that the laser cladding of strategic metals can bring about improvements in the wear behaviour [4-6]. In the same way, laser surface alloying (LSA) [7, 8] and laser surface melting (LSM) [9] have been

found to be workable techniques for increasing the wear resistance of metals. Naturally, much research has revealed that laser surface hardening (LSH) [10-13] effects considerable increases in the wear resistance of metals. Pantelis et al. [14] have investigated the novel technique of laser surface texturing. Using a high power pulsed CO₂ laser, the surface of grey cast iron was textured to produce an anti-galling surface, yielding a marked increase in the wear resistance of the iron.

The direct surface treatment [15-20] and coating [21-24] of engineering ceramic and composite materials with established industrial lasers is a field of ongoing research. What is more, work conducted by Yang et al. [25] to study the effect of LSM on the wear characteristics of Al₂O₃/TiO₂-based ceramic coatings revealed that the wear characteristics of the ceramic were much improved after laser treatment. Such improvements were attributed to laser-induced densification of the ceramic materials and the subsequent increase in the hardness. Even so, little work has been conducted using the more contemporary HPDL. But in a series of comprehensive studies, Lawrence et al. have investigated the potential of the HPDL for the modification of the surface properties of engineering ceramics [26-28], composites [29, 30] and the coating of composites [31]. Likewise, there are very few reports on the efficacy of the HPDL to enhance the wear characteristics of engineering ceramic and composites. However, work carried out by Lawrence and Li [32] demonstrated that the HPDL treatment of the ordinary Portland cement (OPC) surface of concrete effected considerable increases in the wear resistance of the OPC in both normal and corrosive environments.

This study aims to establish the wear characteristics of a HPDL generated single-stage ceramic tile grout and compare them with those of a commercially available epoxy tile grout. This is of particular interest since the inherent compactness of the HPDL enables it to be portable. Other industrial lasers only allow the workpiece to be processed at a dedicated laser work station, whereas on the other hand, the HPDL can be used for on-site processing.

2. Experimental procedures

2.1 Laser processing procedure

The laser used in the study was a surgical HPDL (Diomed Ltd.), emitting at 810 nm ±20 nm and operating in the continuous wave (CW) mode with rated optical powers ranging from 0-60 W. The HPDL beam was delivered to the work area by means of a 4 m long, 600 µm core diameter optical

fibre, the end of which was connected to a 2:1 focusing lens assembly mounted on the z-axis of a 3-axis computerised numerical control (CNC) gantry table (see Fig. 1). The single-stage ceramic tile grout was irradiated using the defocused high order mode HPDL beam within the optimum HPDL operating parameters established previously [3]. Hence a beam spot diameter of 1.75 mm, a laser power (measured at the workpiece after fibre and optics losses using a Power Wizard power meter) of 35 W and a traverse speed of 600 mm/min were used. Fig. 1 illustrates schematically the laser processing experimental arrangement, whereby the defocused HPDL beam was fired along the vitrifiable enamel frit placed in the void between adjoining vitrified ceramic tiles by traversing the samples beneath the HPDL beam using the x- and y-axis of the CNC gantry table. In order to protect the laser optics, 3 l/min of coaxially blown O₂ assist gas was used, whilst the fumes produced were removed with an extraction system.

The experiments were carried out using UK standard 150 x 150 x 5 mm³ vitrified ceramic wall tiles of various colours: white; navy blue; leaf green and jet black, cut into smaller pieces, 20 x 20 mm², for experimental purposes and applied in pairs to an OPC substrate using standard epoxy tile grout (Vallance Ltd). The spacing between the vitrified edges of each tile pair was the industry recommended 1.5 mm. The fixed ceramic tile pieces were then allowed to set for the standard setting time of one day. For the experiments investigating the wear characteristics of the epoxy tile grout, the grout was applied into the void, proud of the surface of the tiles by approximately 500 µm. The grout was then allowed to cure for 8 h. For the experiments investigating the wear characteristics of the HPDL generated single-stage ceramic tile grout, vitrified ceramic tiles were crushed and fine ground using a pestle and mortar and then sieved to ensure a particle size of less than 45 µm. So as to form a manageable paste, the vitrified ceramic tile powder was mixed with approximately 50wt% water diluted sodium silicate solution. The vitrified ceramic tile paste was then placed into the void, proud of the surface of the tiles by approximately 500 µm and allowed to cure for 8 h. The set mixture was then overlaid directly with a thin layer (500 µm) of enamel frit (Ferro Group (UK), Ltd.) which, in order to form a manageable paste, was mixed with 20wt% white spirit. The composition of the enamel consisted mainly of the following: SiO₂; B₂O₃; Na₂O; Mn and small quantities of Ba; Al₂O₃ and Ni, whilst the powder size was 25 µm. The enamel frit paste was allowed to cure for 1 h and then

irradiated immediately with the defocused HPDL beam. The enamel frit was chosen on account of the fact that it has been shown previously to have a high propensity for laser firing [1-3].

To determine the characteristics of the glaze generated on the surface of the single-stage ceramic tile grout seals, the samples were examined using optical microscopy, scanning electron microscopy (SEM), energy disperse X-ray analysis (EDX) and X-ray diffraction (XRD) techniques.

2.3 Wear testing procedure

To determine the wear resistance characteristics of both the epoxy tile grout and the HPDL generated single-stage ceramic tile grout seal, wear tests were conducted in accordance with Fig. 3. All the samples were weighed and then clamped individually in the vice of a common shaping machine. A steel abrader was attached to the floating head of the shaping machine and moved cyclically back and forth across the surfaces of the grout seals. The total distance moved in one cycle was 6 mm while the traverse speed was 180 mm/min. By applying weights to the floating head a frictional force of 60 N was generated. The samples were subjected to the frictional force for 8 h, being removed from the machine and weighed at 2 h intervals. The wear tests were repeated twice so as to give more reliable results. The standard deviation due to experimental error, etc. was calculated as being ± 15 mg.

3. Results

3.1 Wear characteristics in normal environmental conditions

In most instances, the wear resistance of any material is principally related to the hardness of the material in comparison with that of any other material with which it subsequently comes into contact [33]. As such, with the compositional components of the enamel frit employed (mainly SiO_2 , B_2O_3 , Na_2O and Mn) being naturally much harder than those of the epoxy tile grout (mainly CaCO_3 and dolomite), then one would expect the glazed enamel surface of the single-stage ceramic tile grout seal to provide the seal with greater wear resistance than the epoxy tile grout alone. Yet wear resistance is not directly proportional to hardness, nor does it always increase with hardness [34]. Fig. 4 shows the relationship between weight loss and the friction time for the HPDL generated enamel glaze and the epoxy tile grout. As is clearly evident from Fig. 4, the HPDL generated enamel glaze possesses a

much greater wear resistance than the epoxy tile grout, with the weight loss being 9 times lower than for the epoxy tile grout after 4 h, and 14 times lower after 8 h.

3.2 The effect of corrosive environments on the wear characteristics

Tiled surfaces are almost always subjected to corrosive substances, either as part of the normal service environment and/or as a result of routine cleaning. Consequently, corrosion resistance tests based upon EN ISO 10545 [35] were conducted using nitric acid (HNO_3), sodium hydroxide (NaOH) and a detergent cleaner (MP9, Premier Products). The experiments were carried out by placing small amounts of the corrosive agents in the concentration ratios of 80%, 60%, 40%, 20% and 10%, on to the surfaces of the HPDL generated enamel glaze and the epoxy tile grout at hourly intervals for 4 h. The samples were then examined optically and mechanically tested in terms of compressive strength and wear. High concentrations of the various corrosive agents were used primarily to accelerate the tests. Indeed, in practice nitric acid is used within the nuclear processing industry as a solvent for nuclear fuels in only 60% concentration [36], whilst within the food processing and brewing industries, tiled surfaces are washed repeatedly, many times a day with detergent cleaners [37].

All three reagents in the concentrations 80%, 60% and 40% were seen to immediately attack the epoxy tile grout surface. In particular, the HNO_3 and the NaOH attacked the epoxy tile grout surface with a much greater severity than the detergent, causing marked discoloration and heavy pitting after only 1 h, as Fig. 5 shows. In contrast, the surface of the HPDL generated enamel glaze displayed no discernible changes in either morphology or microstructure. Furthermore, no signs of devitrification due to corrosion were discernible.

Tests conducted in accordance with ASTM C579-91 [38] revealed that exposure of the epoxy tile grout surface to the reagents had a significant effect on the compressive strength and the wear resistance. From Fig. 6 it can be seen that exposure of the epoxy grout to HNO_3 and NaOH in the concentrations 40-80% resulted in an average loss of compressive strength of approximately 35-71%. In the case of the detergent a significant loss in compressive strength only occurred with concentrations above 40%. In this instance the average loss in compressive strength for concentrations in the range 60-80% was approximately 15-30%. This compares sharply with no discernible difference in either the wear resistance or the compressive strength of the HPDL generated enamel glaze.

Fig. 7 shows the variation in wear resistance of the epoxy tile grout when exposed to the reagents with 80% concentration. As one can see, the wear resistance is significantly affected, particularly through interaction with the NaOH and the HNO₃, which yielded similar results. Here the weight loss was approximately 5 times higher than for the unexposed epoxy tile grout after 4 h, 45 mg/cm² and 294 mg/cm² (HNO₃), and approximately 10 times higher after 8 h, 97 mg/cm² and 986 mg/cm² (HNO₃). In the case of the detergent, the weight loss was twice as high as that recorded for the unexposed epoxy tile grout after 4 h, 45 mg/cm² and 102 mg/cm² respectively, and 4 times higher after 8 h, 97 mg/cm² and 415 mg/cm² respectively.

4. Discussion

It is abundantly clear from the results of the wear tests that the HPDL generated enamel glaze possesses far superior wear resistance characteristics than the epoxy tile grout. This superiority in wear characteristics was especially evident when the tests were conducted in corrosive environments. The marked difference in wear rate between the HPDL generated enamel glaze and the epoxy tile grout, in both normal and corrosive environments, can be attributed entirely to the difference in the structure and phase of the two materials. Whereas the HPDL generated enamel glaze is fully amorphous in nature (see Fig. 8(a)), the epoxy tile grout is comprised of a porous polycrystalline structure (see Fig. 8(b)). Furthermore, the HPDL induced vitrification of the enamel has inherently created a surface that is much more dense and consolidated than the epoxy tile grout. In addition, the HPDL generated enamel glaze is considerably harder than the epoxy tile grout, with a respective value of 6 compared to 2 on the Mohs scale. Consequently, these two differences in the nature of the HPDL generated enamel glaze will in turn afford the HPDL generated enamel glaze wear characteristics that exceed those of the epoxy tile grout. Moreover, owing to the amorphous nature of the HPDL generated enamel glaze, the glaze will naturally possess a greater resistance to corrosive reagents than the polycrystalline structure of the epoxy tile grout which is readily attacked by acids and alkalis [39]. Indeed, from a microscopic examination of the HPDL generated enamel glaze, no signs of devitrification due to corrosion were discernible.

It is interesting to note that the weight loss experienced by the single-stage ceramic tile grout seal during the wear tests increased linearly, as opposed to rising increasingly with time. From this

observation it is possible to make two assertions. Firstly, such a finding implies that the surface of the HPDL generated enamel glaze is without protrusions that are naturally more susceptible to wear [32]. Indeed, the average surface roughness (Ra) of the HPDL generated enamel glaze was recorded as 0.12 μm . This compares with an average surface roughness value of 3.83 μm for the epoxy tile grout. Secondly, it is reasonable to maintain that the HPDL generated enamel glaze does not have an upper layer that possesses superior wear characteristics over the bulk of the glaze. That is, throughout the 500 μm section of the HPDL generated glaze the wear characteristics are somewhat consistent.

The generally superior mechanical and chemical performance of the HPDL generated enamel glaze over the epoxy tile grout suggests that the life characteristics of the enamel glazes may also be superior to those of the epoxy tile grout. Yet in any analysis of the wear life of these two materials, the in-situ relative thickness of the HPDL generated enamel glaze and the epoxy tile grout must be considered in order to give a true interpretation of the actual life characteristics. This is particularly true when considering the wear resistance (with and without exposure to corrosive chemical agents). Consequently, the increase in wear life can be given by

$$\text{Increase in wear life} = \frac{\text{HPDL generated enamel glaze wear life}}{\text{Epoxy tile grout wear life}} \quad (1)$$

where,

$$\text{Wear life} = \frac{\text{Density} \cdot \text{Thickness} (\text{mg} / \text{m}^3 \cdot \text{cm})}{\text{Wear rate} (\text{mg} / \text{cm}^2 / \text{h})} \quad (1a)$$

Table 1 summarises the wear rate details and the nominal life increase of the HPDL generated enamel glaze over the epoxy tile grout. As is clearly apparent from Table 1, the HPDL generated enamel glaze effected an increase in actual life over the epoxy tile grout regardless of the environment. What is more, it can be seen that the increase in actual life of the HPDL generated enamel glaze over the epoxy tile grout varies considerably depending upon the working environment. However, arguably the most common working environment for a tiled surface would involve some contact with at least detergents, therefore yielding significant economic benefits since a HPDL sealed tiled surface lasts around 17.5-times longer than one which is sealed in the conventional way with epoxy tile grout.

5. Conclusions

The wear characteristics of a single-stage ceramic tile grout, generated using a 60 W high power diode laser (HPDL), in comparison to those of a commercially available tile grout have been determined. Within both normal and corrosive (detergent, HNO₃ and NaOH) environmental conditions the wear rate of the single-stage ceramic tile grout was found to be 0.9 mg/cm²/h. In contrast, the wear rate of the epoxy tile grout after 8 h was 12 mg/cm²/h in normal environmental conditions and 52, 92 and 125 mg/cm²/h when exposed to detergent, NaOH and HNO₃ respectively. Life assessment testing revealed that the HPDL generated enamel glaze gave an increase in wear life of 4 to 42 times over epoxy tile grout, depending upon the corrosive environment. It is believed that the economic and material benefits to be gained from the deployment of such an effective and efficient means of sealing ceramic tiles could be significant.

The reasons for these marked improvements in the wear resistance and wear life of the HPDL generated enamel glaze over the epoxy tile grout can be attributed to firstly, the vitrified nature of the HPDL generated enamel glaze which subsequently yields a much more dense and consolidated surface in comparison with the epoxy tile grout, and secondly, the fact that the HPDL generated enamel glaze possesses microstructural and phase characteristics that are inherently more resistant to corrosive reagents than the epoxy tile grout.

Acknowledgements

The authors would like to express their gratitude to the EPSRC: Process Engineering Group (Grant No. GR/M46068) for their financial support of this work. The authors are also grateful to BNFL, Diomed Ltd., Ferro Group (UK) Ltd. and Ove Arrup & Partners for their valuable technical assistance.

References

1. J. Lawrence, L. Li, J.T. Spencer, A two-stage ceramic tile grout sealing process using a high power diode laser. Part I: Grout development and materials characteristics, *Optics, Laser Tech.* 30 (1998) 205-214.
2. J. Lawrence, L. Li, J.T. Spencer, A two-stage ceramic tile grout sealing process using a high power diode laser. Part II: Mechanical, chemical and physical properties, *Optics Laser Tech.* 30 (1998) 215-223.
3. J. Lawrence, L. Li, R.E. Edwards, A.G. Gale, The single-stage sealing of ceramic tiles by means of high power diode laser radiation, *J. Laser Apps*, to be published.
4. T. Zhao, X. Cai, S.X. Wang, S. Zheng, Effect of CeO₂ on microstructure and corrosive wear behaviour of laser clad Ni/WC coating, *Thin Solid Films*, 379 (2000) 128-132.
5. R.L. Sun, D.Z. Yang, L.X. Guo, S.L. Dong, Microstructure and wear resistance of NiCrBSi laser clad layer on titanium alloy substrate, *Surf. Coatings Tech.* 132 (2000) 251-255.
6. J. Choi, S.K. Choudhuri, J. Mazumder, Role of pre-heating and specific energy input on the evolution of microstructure and wear properties of laser clad Fe-Cr-C-W alloys, *J. Mater. Sci.* 35 (2000) 3213-3219.
7. P. Jiang, X.L. He, X.X. Li, L.G. Yu, H.M. Wang, Wear resistance of a laser surface alloyed Ti-6Al-4V alloy, *Surf. Coatings Tech.* 130 (2000) 24-28.
8. J.D. Majumdar, B.L. Mordike, L. Manna, Friction and wear behaviour of Ti following laser surface alloying with Is, Al and Si plus Al, *Wear*, 242 (2000), 18-27.
9. A. Roy, I. Manna, Laser surface engineering to improve wear resistance of austempered ductile iron, *Mater. Sci. Eng. A.* 297 (2001) 85-93.
10. A.N. Safonov, S.I. Aleksenko, Effect of laser treatment on the wear resistance of steels, *Metal Sci, Heat Treatment*, 40 (1998) 399-401.
11. X.M. Zhang, H.C. Man, H.D. Li, Wear and friction properties of laser surface hardened En31 steel, *J. Mater. Proc. Tech.* 69 (1997) 162-166.

12. Y.B. Liu, J.D. Hu, Z.Y. Cao, P.K. Rohatgi, Wear resistance of laser processed Al-Is-graphite(p) composites, *Wear*, 206 (1997) 83-86.
13. J. Ruiz, V. Lopez, B.J. Fernandez, Effect of surface laser treatment on the microstructure and wear behaviour of grey iron, *Mater. Design*, 17 (1996) 267-273.
14. D.I. Pantelis, G. Pantazopoulos, S.S. Antoniou, Wear behaviour of anti-galling surface textured grey cast iron using pulsed CO₂ laser treatment, *Wear* 205 (1997) 178-185.
15. A. Adamski, R. McPherson, Laser sealing of ceramic surface layers, Proceedings of the 11th International Thermal Spraying Conference, Los Angeles, CA, 1986 (ASME, New York, 1986) 555-564.
16. B. L. Mordike, R. Sivakumar, Laser surface melting of ZrO₂ protective layers, Proceedings of ECLAT '86, Berlin, Germany, 1986 (SPIE, Bellingham, WA, 1986) 373-381.
17. R. Sivakumar, B. L. Mordike, Laser melting of plasma sprayed ceramic coatings, *J. Surf. Eng.* 4 (1988) 127-140.
18. L. Bradley, L. Li, F.H. Stott, Flame-assisted laser surface treatment of refractory materials for crack-free densification, *Mater. Sci. Eng. A*, 278 (2000) 204-212.
19. J. Lawrence, L. Li, Comparison of surface glaze characteristics of concrete treated with a CO₂ laser and a high power diode laser Part. I: Glaze formation mechanisms and characteristics, *Mater. Sci. Eng. A*, 284 (2000) 93-102.
20. J. Lawrence, L. Li, Comparison of surface glaze characteristics of concrete treated with a CO₂ laser and a high power diode laser. Part II: Mechanical, chemical and physical properties, *Mater. Sci. Eng. A*, 287 (2000) 25-29.
21. J. Yu, W. Wu, M. Wang, Preparation of enamel coating by laser irradiation, *Chinese J. Lasers*, B2 (1993) 377-383.
22. M. Wang, J. Yu, J. Chen and W. Wu, Laser cladding of oxide-ceramic powder with enamel frit on a steel substrate, Proceedings of ICALEO '95, San Diego, CA, 1995 (Laser Institute of America, Orlando, FL, 1996) vol 80, 699-709.

23. C. Buerhop, R. Weissmann, Enamelling of glass by CO₂ laser treatment, *Glass Sci. Tech.* 68 (1995) 147-152.
24. K. Hahn, C. Buerhop, R. Weissmann, Firing of PbO-free glass enamels using the CO₂ laser, *Glass Sci. Tech.* 69 (1996) 1-6.
25. Y.Z. Yang, Y.L. Zhu, Z.Y. Liu, Y.Z. Chuang, Laser remelting of plasma sprayed Al₂O₃ ceramic coatings and subsequent wear resistance, *Mater. Sci. Eng. A*, 291 (2000) 168-172.
26. J. Lawrence, L. Li, J.T. Spencer, Diode laser modification of ceramic material surface properties for improved wettability and adhesion, *Appl. Surf. Sci.* 138/139 (1999) 388-393.
27. J. Lawrence, L. Li, J.T. Spencer, High power diode laser modification of the wettability characteristics of an Al₂O₃/SiO₂ based oxide compound for improved enamelling, *Mater. Sci. Eng. A*, 266 (1999) 1067-1074.
28. J. Lawrence, L. Li, J.T. Spencer, The effects of high power diode laser radiation on the wettability, adhesion and bonding characteristics of an alumina/silica-based oxide and vitreous enamel, *Surf. Coatings Tech.* 115 (1999) 273-281.
29. J. Lawrence, L. Li, High power diode laser surface glazing of concrete, *J. Laser Apps*, 12 (2000), 116-125.
30. J. Lawrence, L. Li, The influence of a high power diode laser (HPDL) generated glaze on the wetting characteristics and the subsequent HPDL enamelling of ordinary Portland cement, *Surf. Coatings Tech.* 137 (2001) 77-85.
31. J. Lawrence L. Li, The enamelling of concrete for improved performance characteristics by means of high power diode laser interaction, *J. Mater. Proc. Tech.* (submitted)
32. J. Lawrence, L. Li, The wear characteristics of a high power diode laser generated glaze on the ordinary Portland cement surface of concrete, *Wear* 246 (2000) 91-97.
33. H. Dickson, *Glass: A Handbook for Students and Technicians*, Hutchinsons Scientific and Technical Publications, 1951, p. 148.
34. A. Petitbon, L. Boquet, D. Delsart, Laser surface sealing and strengthening of zirconia coatings, *Surf. Coat. Tech.* 49 (1991) 57-61.

35. EN ISO 10545: Part 13: 1997, Ceramic Wall and Floor Tiles: Method for Determination of Chemical Resistance. Glazed Tiles.
36. J.T. Spencer, Letter to Author, October 1997.
37. J. Verran, Letter to Author, October 1997.
38. ASTM C597-91, Standard Test Method for Compressive Strength of Chemical-Resistant Mortars, Grouts, Monolithic Surfacing and Polymer Concretes.
39. V.V. Vargin, Technology of Enamels, MacLaren & Sons, London, 1965, pp. 125-128.

List of Figures

Fig. 1. Schematic illustration of the experimental set-up for the single-stage ceramic tile grout sealing process using the HPDL.

Fig. 2. Schematic illustration of the single-stage ceramic tile grout seal.

Fig. 3. Schematic illustration of the experimental set-up for the wear tests.

Fig. 4. Relationship between weight loss and friction time for the untreated and HPDL generated glaze on the OPC surface of concrete.

Fig. 5. Surface condition of the epoxy tile grout (a) untreated and after exposure to (b) 80% concentration nitric acid, (c) 80% concentration sodium hydroxide alkali and (d) 80% concentration detergent.

Fig. 6. Variation in compressive strength of epoxy tile grout with reagent type and reagent concentration.

Fig. 7. Relationship between weight loss and friction time for the epoxy tile grout with different reagent types at the maximum concentration (80%).

Fig. 8. XRD analysis of (a) the HPDL generated enamel glaze and (b) the epoxy tile grout.

Fig. 1

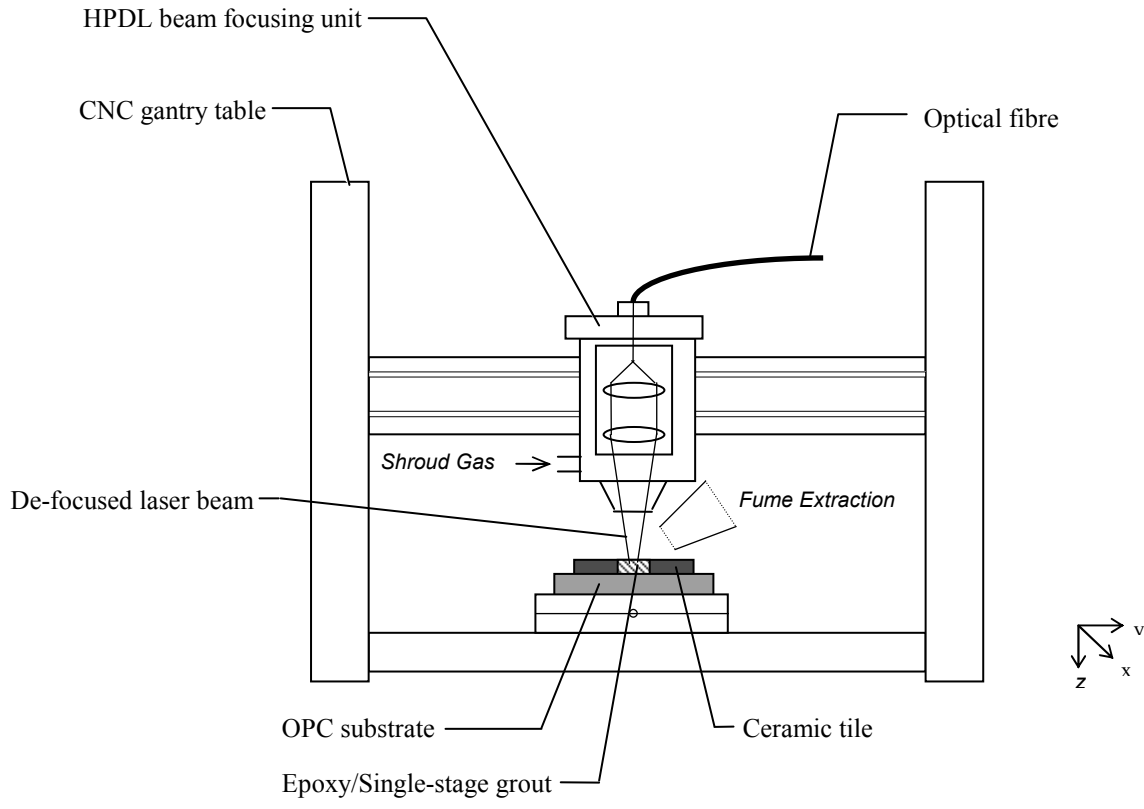

Fig. 2

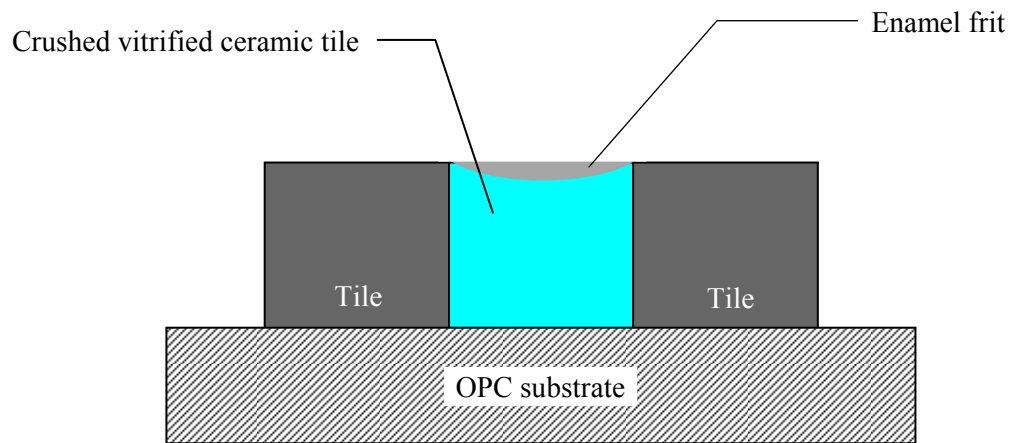

Fig. 3

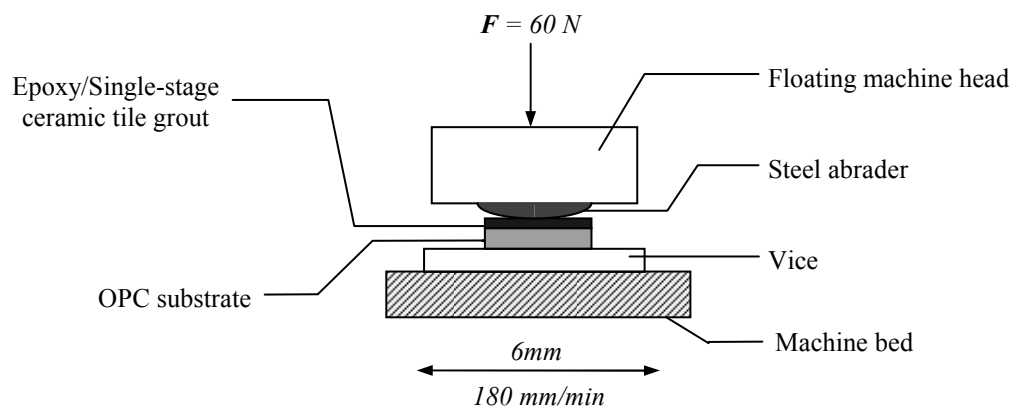

Fig. 4

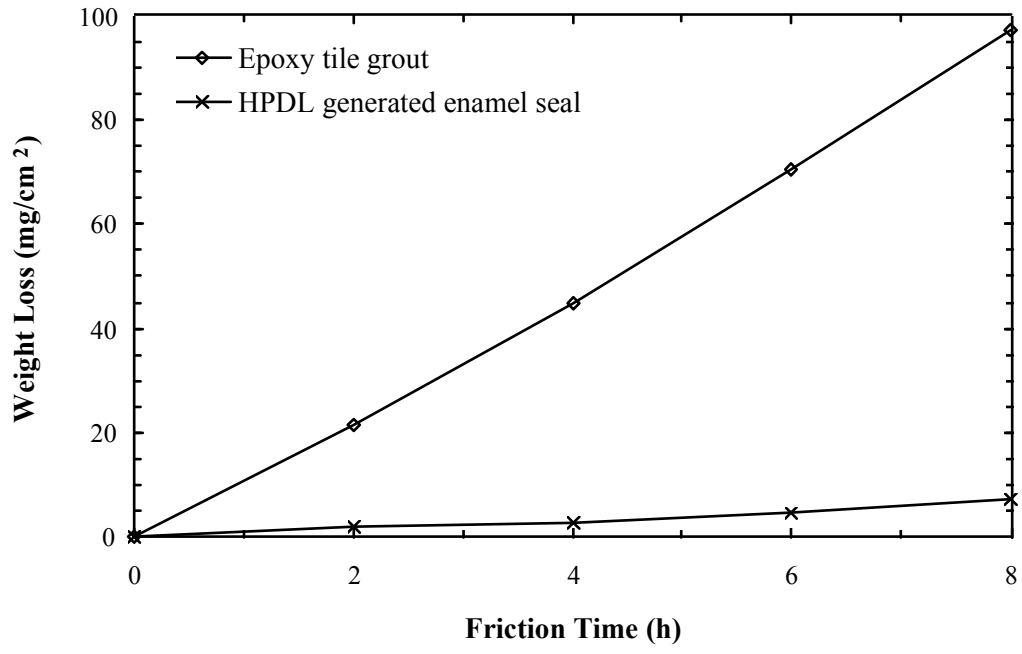
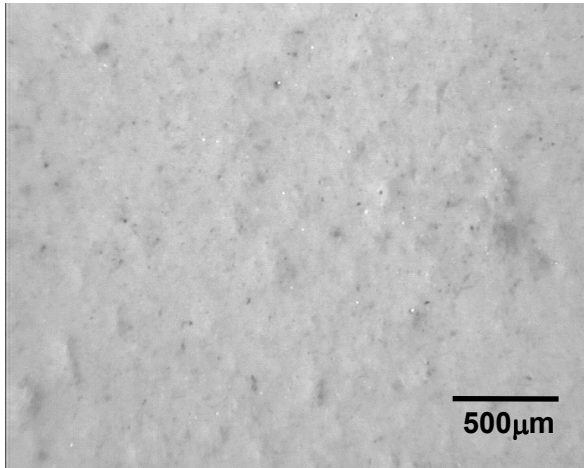
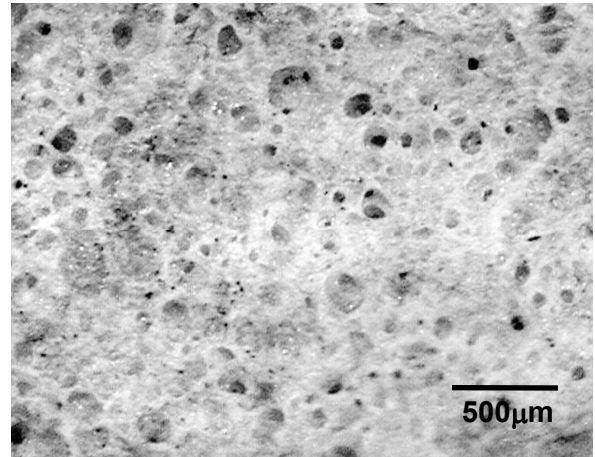

Fig. 5



(a)



(b)

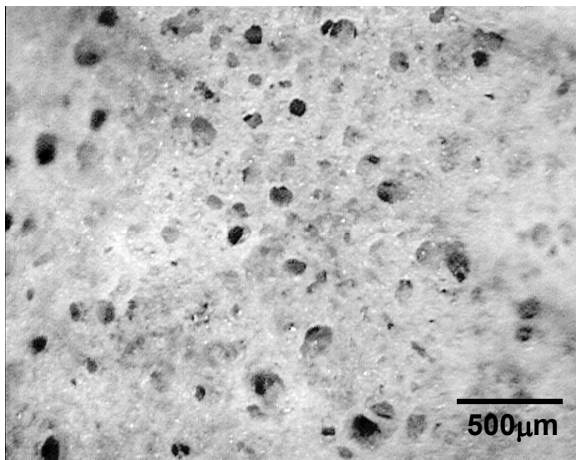

(c)

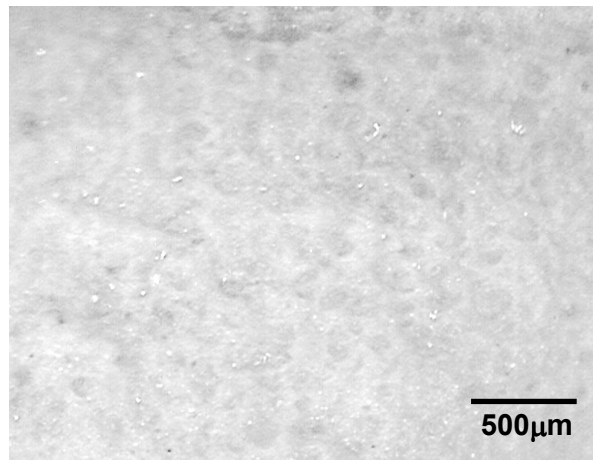

(d)

Fig. 6

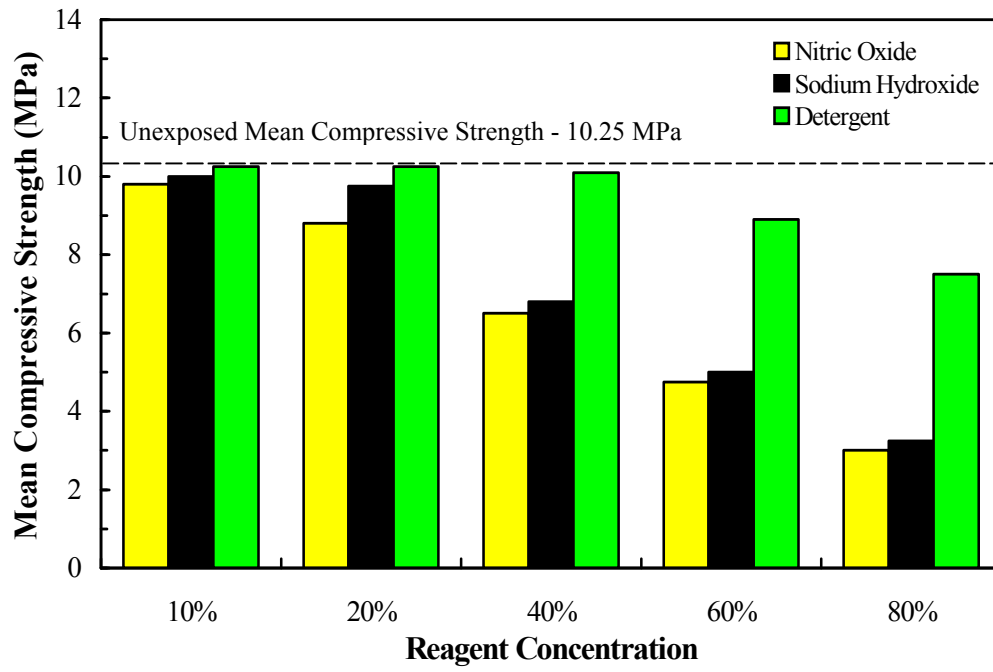

Fig. 7

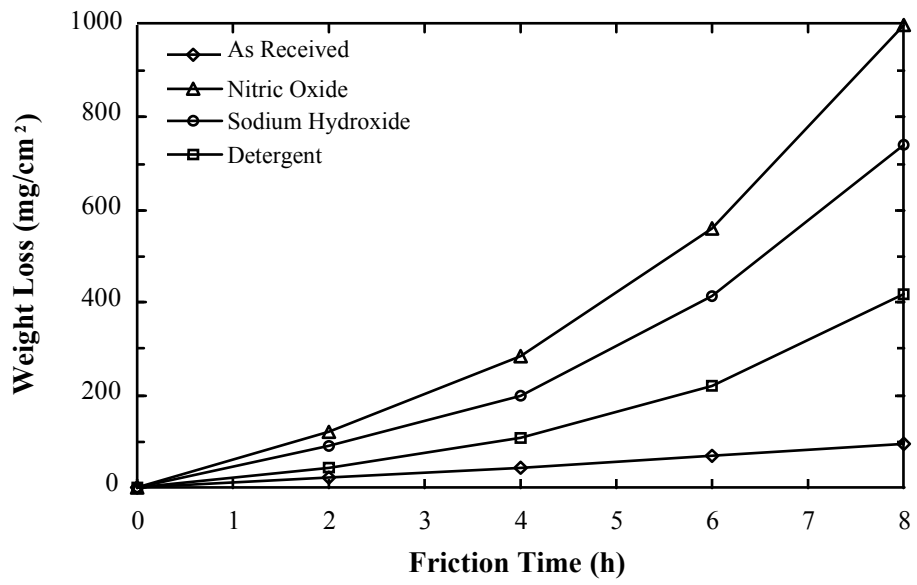
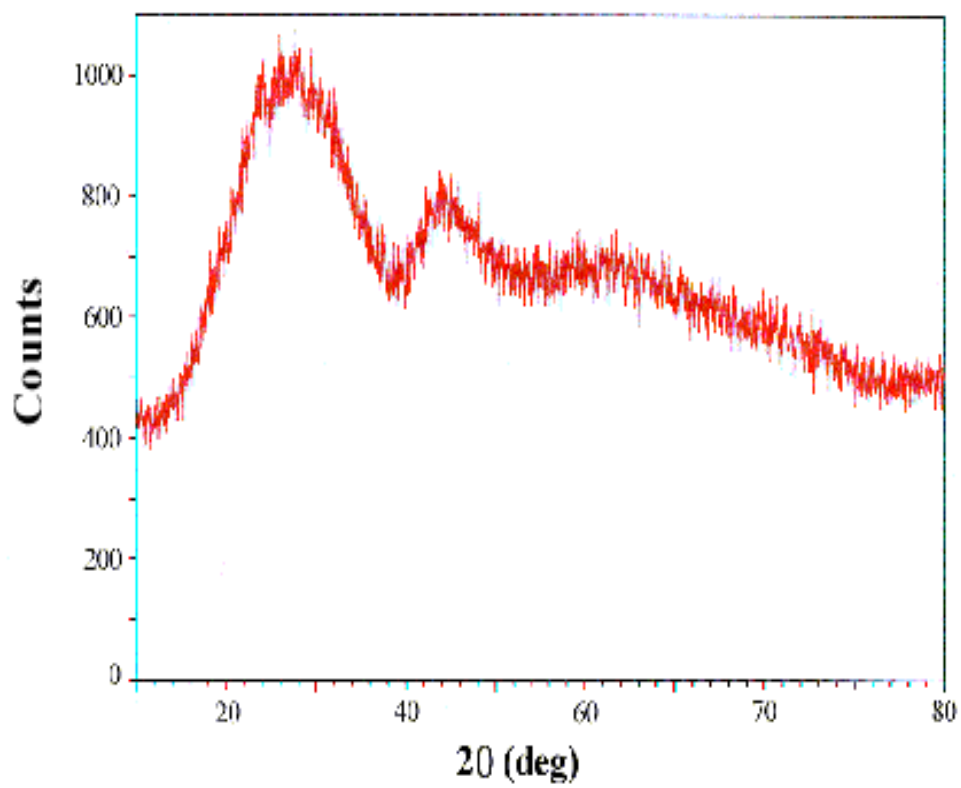
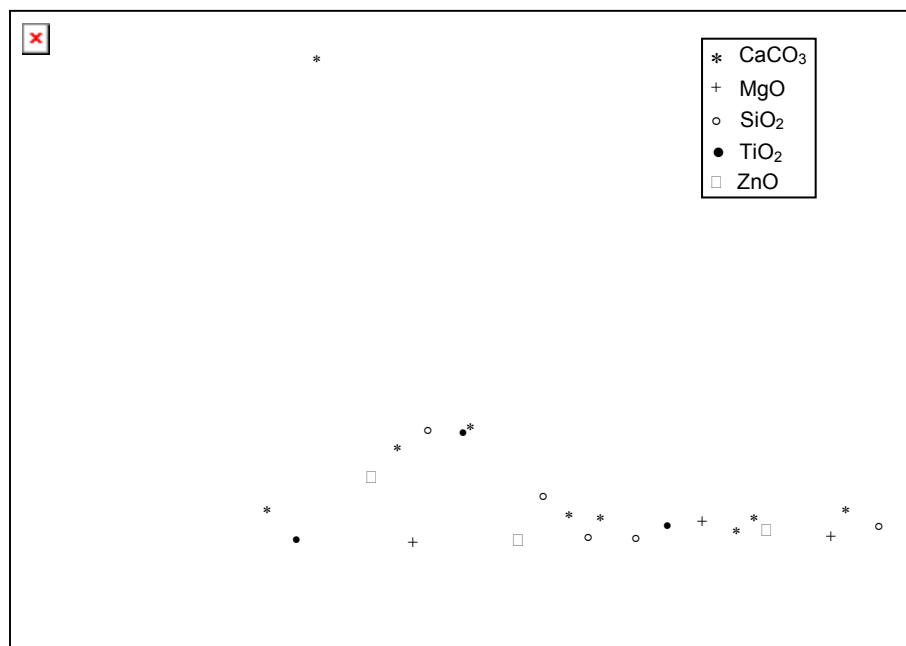

Fig. 8



(a)



(b)

List of tables

Table 1. Wear rate details and the nominal life increase of the HPDL generated enamel glaze over epoxy tile grout in various corrosive environments.

Table 1.

	Density	Thickness	<u>Wear Rate (mg/cm²/h)</u>			
			Unexposed	Detergent	NaOH	HNO₃
Epoxy tile grout	2220 (kg/m ³)	2000 (μm)	12.1	51.9	91.9	123.3
Enamel glaze	2650 (kg/m ³)	500 (μm)	0.9	0.9	0.9	0.9
			4.0	17.5	31.3	42.0