



DESIGN AND ANALYSIS OF INTERNAL HINGE CHECK VALVE

Praneeth Narasimman, Syed Bilal Quadri, Abhinay Suhas Todmal,
Dr. Jeremy Zheng Li (advisor)
Department of Mechanical Engineering
University of Bridgeport, Bridgeport, CT

ABSTRACT

The advent of computers and the tremendous strides they have made in the recent times have brought the capability to model complex design and solve innumerable number of mathematical equations in a flash of time, to the desktop of the design engineer. CREO is windows based software package, which enables the design and Ansys will analyse the mechanical and other system. This project is to design 16” Class 300 Internal Hinge Swing Check Valve with compliance to BS 1868 standard. The internal hinge check valve design is to overcome the leakage issue in external hinge design. The aim is to design a check valve without puncturing the body and to assemble the whole disc sub-assembly inside the body. The design of internal hinge check valves is carried out with the help of CREO design software and subsequently analysis is done with the help of ANSYS software package.

SWING CHECK VALVE

A swing check valve is a butterfly-style check valve in which the circle, the versatile part to obstruct the water, swings on a pivot or trunnion, either onto the seat to close switch stream or off the seat to permit forward stream. The seat opening cross-area might be opposite to the centerline between the two ports or at a point. In spite of the fact that swing check valves can come in different sizes, expansive check valves are regularly swing check valves.

CIRCUMFERENTIAL or HOOP STRESSES

$$\sigma_c = 55.27 \text{ MPa}$$

The circumferential stress developed while testing at a Maximum pressure of 7.75 MPa is said to be $\sigma_c = 55.27 \text{ MPa}$.

LONGITUDINAL STRESSES

$$\sigma_l = 27.63 \text{ MPa}$$

The longitudinal stress developed while testing at Maximum pressure of 7.75 MPa is said to be $\sigma_l = 27.63 \text{ MPa}$.

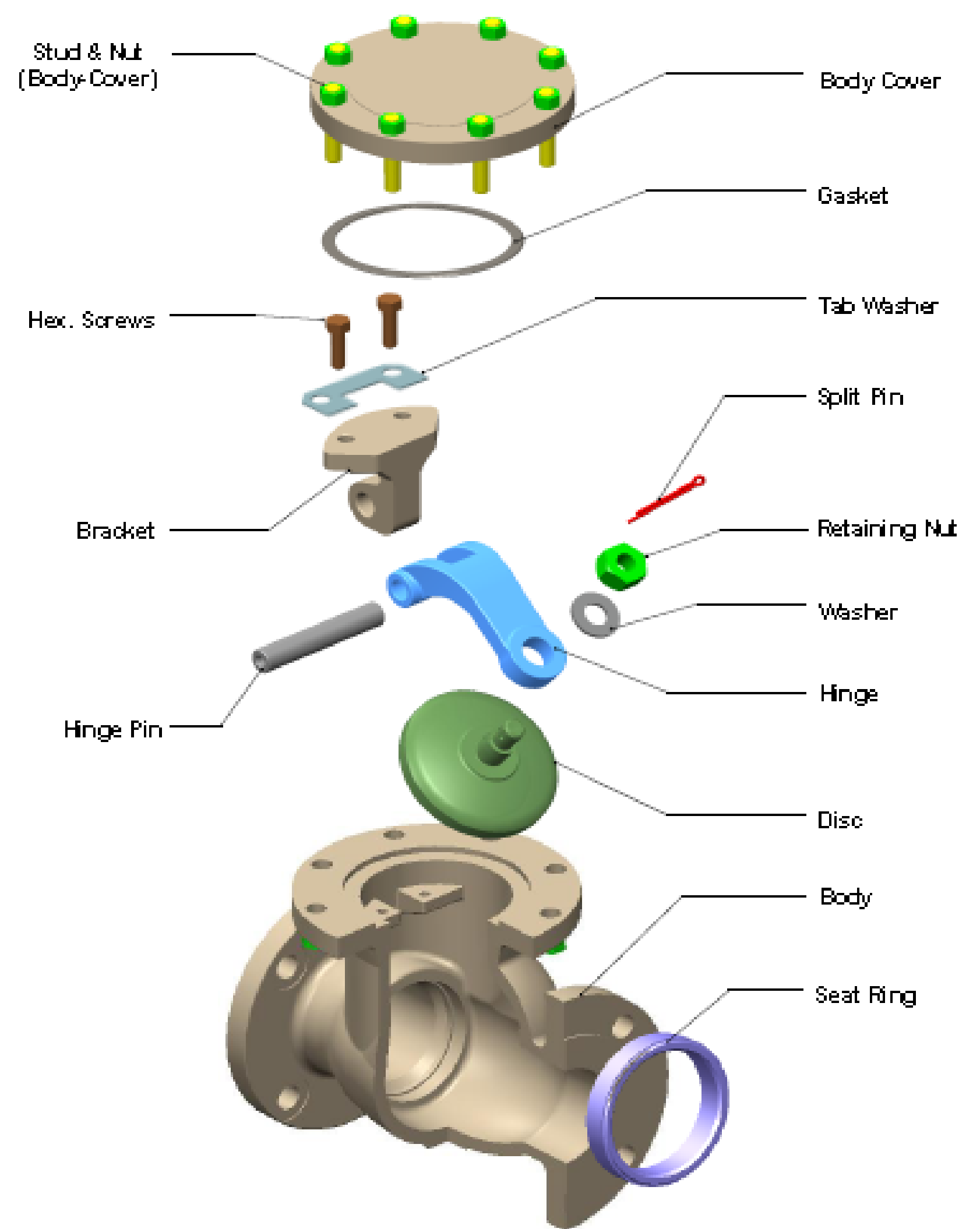

Exploded view of Internal Hinge Check Valve

Analysis Equivalent stress

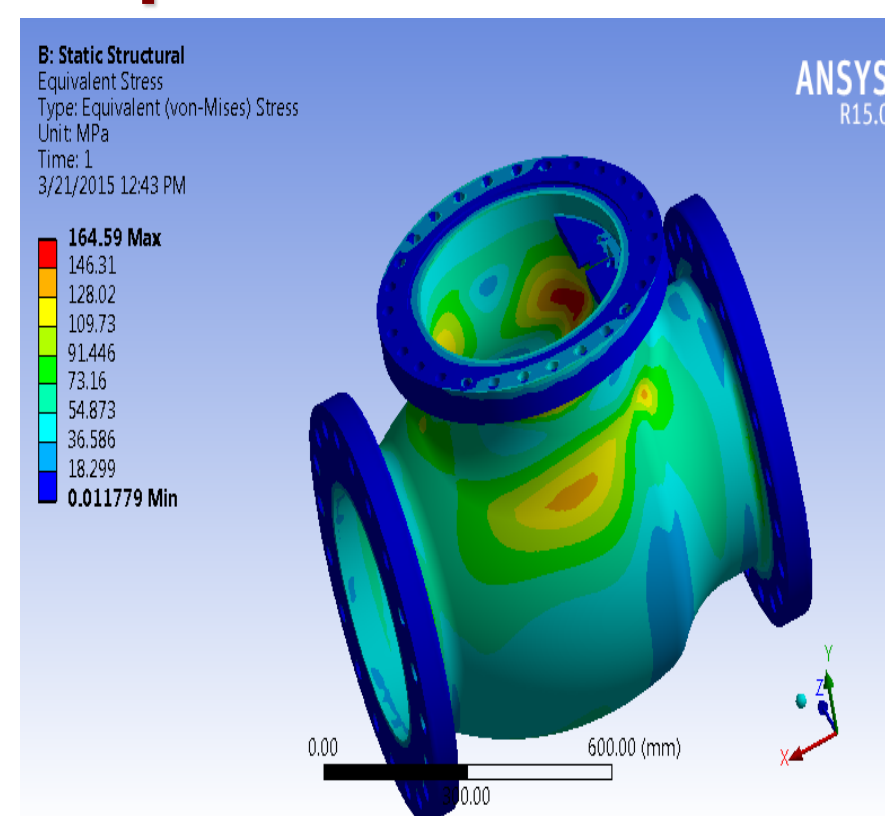

Total Deformation

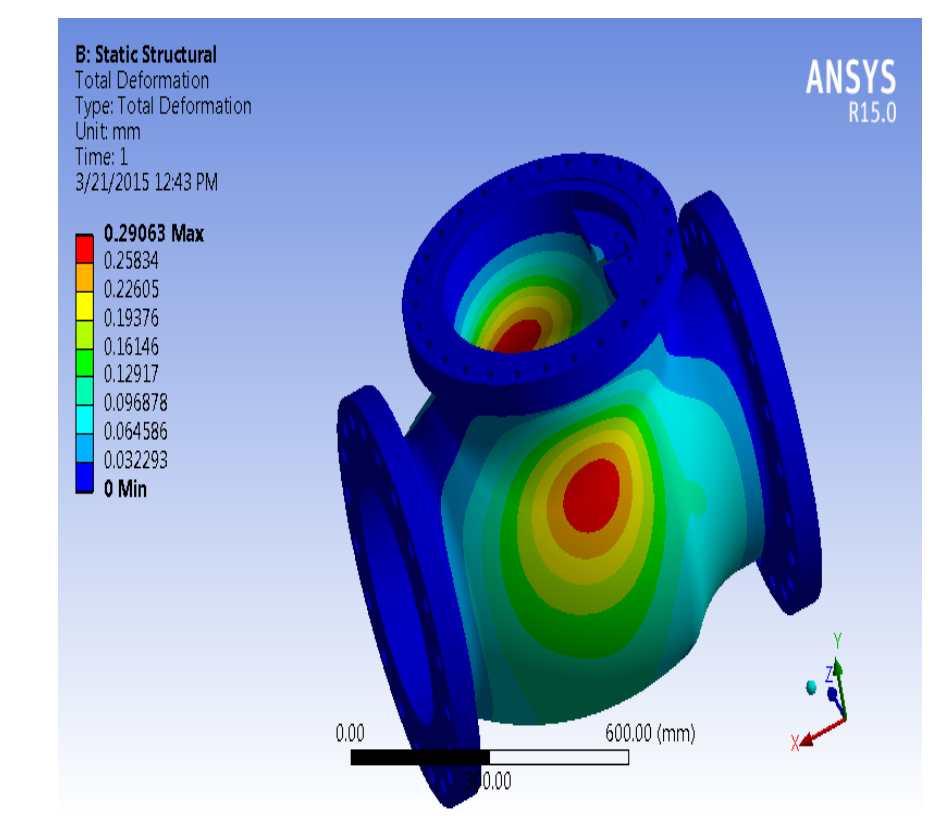

Conclusion

This project has been done by means of the effective tool of CREO and ANSYS to the best of our knowledge. We used these tools for various design and analysis. Overall we found to be satisfied with the way we learnt the design and analysis software.

Acknowledgements

Our sincere thanks to Prof. Jeremy (Zheng) Li from university of Bridgeport for his suggestions, guidance and valuable time.

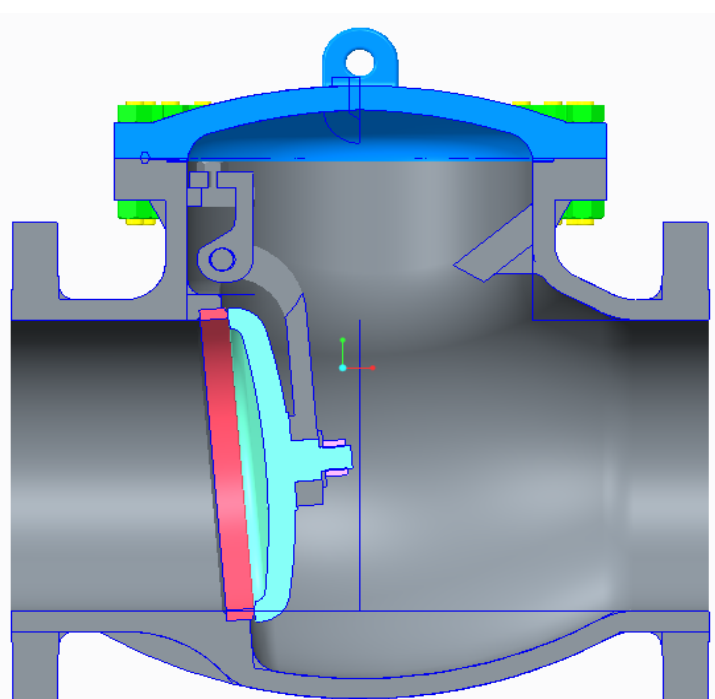

When Disc is Closed

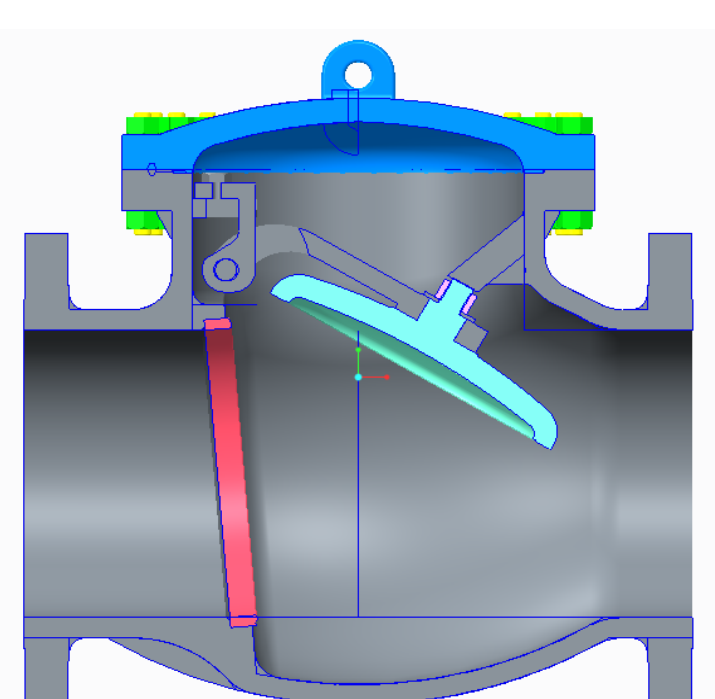

When disc is opened