



# Electrical Tree Growth under Square Wave Voltages with DC Bias

[Link to publication record in Manchester Research Explorer](#)

## Citation for published version (APA):

Aldawsari, F., Rowland, S., & McDonald, H. (2022). Electrical Tree Growth under Square Wave Voltages with DC Bias. In *International Conference on Dielectrics IEEE*.

## Published in:

International Conference on Dielectrics

## Citing this paper

Please note that where the full-text provided on Manchester Research Explorer is the Author Accepted Manuscript or Proof version this may differ from the final Published version. If citing, it is advised that you check and use the publisher's definitive version.

## General rights

Copyright and moral rights for the publications made accessible in the Research Explorer are retained by the authors and/or other copyright owners and it is a condition of accessing publications that users recognise and abide by the legal requirements associated with these rights.

## Takedown policy

If you believe that this document breaches copyright please refer to the University of Manchester's Takedown Procedures [<http://man.ac.uk/04Y6Bo>] or contact [uml.scholarlycommunications@manchester.ac.uk](mailto:uml.scholarlycommunications@manchester.ac.uk) providing relevant details, so we can investigate your claim.



# Electrical Tree Growth under Square Wave Voltages with DC Bias

Faisal Aldawsari, Harry McDonald and Simon M. Rowland  
The University of Manchester  
School of Electrical and Electronic Engineering  
Manchester, M13 9PL UK

**Abstract-** Electrical tree growth in epoxy resin under square waves superimposed with DC voltages is studied in this paper. Using the needle-plane configuration, a  $\pm 15$  kV DC voltage superimposed on a 15 kV pk 50 Hz square wave was applied to grow electrical trees. A standard 50 Hz sinusoidal source was also used for comparison. A CCD camera imaged the electrical tree growth during testing and associated partial discharges were recorded. It was observed that the tree shape under 15 kV square-wave voltages combined with positive or negative 15 kV DC voltages are branch-like, whereas bush-branch trees grow under 15 kV bipolar square-wave voltages. Positive unipolar square-wave voltages resulted in faster growth than negative unipolar square waves. The different tree structures were also associated with distinct characteristic PD activity.

**Keywords**—electrical tree; epoxy resin; bipolar; unipolar; square wave; partial discharge

## I. INTRODUCTION

Power electronic converters in DC transmission systems are known to introduce harmonic components into the system. It is suspected that such harmonics may cause a reduction in the reliability of the DC side of such electrical power networks. These harmonics distort currents and voltages and it is important to establish whether this results in an acceleration of the aging process of the insulation system [1]. A failure in the insulation of an asset can cause its complete breakdown and trigger wider scale issues in an electrical power system. As such, it is critical to understand the effect of harmonics upon DC systems.

Electrical trees are gaseous channels formed under high, divergent electrical fields in a polymeric insulation system. Electrical trees are initiated in cable systems at defects, impurities and protrusions. Electrical tree formation is usually associated with partial discharge (PD) activity. One proposed mechanism for electrical tree initiation in cables is that PD activity occurs due to high voltage stress at a geometric abnormality and subsequently erodes the insulating polymer adjacent to the defect, creating a non-conducting void. After a period of time, these voids develop in length, forming non-conducting channels. After a further period of exposure to PD activity the channels can become carbonized and so consequently conductive, thereby giving rise to local electric field enhancement at the channel tips, which results in further rapid electric tree formation [2].

Numerous studies have investigated the influence of electrical trees on insulation materials, and more recently some have considered the impact of square waves. Fu et al [3] studied the influence of bipolar square-wave voltages in epoxy

resin at frequencies from 50 to 500 Hz. The results showed that electrical trees grow faster under higher frequencies and the number of tree branches increased with increasing frequency. Wang et al [4] identified that the probability of tree initiation under a bipolar square wave was higher for higher frequencies and with shorter rise times.

Iddrissu et al [5] investigated electrical tree growth in epoxy resin with sinusoidal AC superimposed on DC voltages. They showed that the impact of positive DC bias is more aggressive than negative bias, and PD characteristics vary with the tree structure. Zheng et al [6] studied the influence of combined AC and DC voltages on electrical treeing in low-density polyethylene, indicating that superimposing negative DC bias reduced the time for tree initiation compared with positive DC bias. Liu et al [7] investigated growth and discharge characteristics of electrical trees in XLPE under AC and DC composite voltages, which revealed that the growth rates under positive DC bias are faster than with negative DC bias or pure AC voltages.

Many of the previous studies focused on the behavior of harmonics in electrical insulation on the AC side and less attention was paid to ripple on the DC side. In this study, as a step towards experimentally adding square-wave voltages to high voltage DC in treeing experiments, the influence of step voltages in epoxy resin were investigated by superimposing 15 kV square-wave voltages with 15 kV DC voltages to produce positive and negative unipolar waveforms.

## II. EXPERIMENTAL METHODOLOGY

### A. Sample Preparation

A low viscosity epoxy resin Araldite LY 5052 and the corresponding hardener Aradur HY 5052, supplied by Huntsman, were used in this study. These were mixed according to the ratio 100:38 by weight, indicated by the manufacturer. The hardener was added to the epoxy and then mixed in a beaker for two minutes by hand, followed by magnetic stirring for 5 minutes. The mixing process results in trapped air bubbles which need to be removed by degassing. The epoxy resin mixture is degassed in a vacuum chamber for 40 minutes. The degassed mixture is then carefully poured into acrylic cubes and an Ogura® needle (3  $\mu\text{m}$  tip radius) is embedded 2 mm from the bottom surface. The samples are then allowed to cure at room temperature for 24 hours, followed by a further 4 hours of post curing at 100°C to achieve consistent sample characteristics. After 4 hours, the oven is switched off and left to cool before the samples are removed. This slow cooling avoids rapid thermal changes

which could place strains upon the sample due to thermal contraction. The final stage is removing the acrylic cubes and polishing the epoxy surfaces to improve the quality of the optical images.

### B. Experimental Setup

A TREK HV amplifier was used to supply the high voltage waveform. A 1 MΩ resistor protected equipment during breakdown events. The output of the HV amplifier was monitored by an oscilloscope through a 10000:1 voltage divider. All samples were immersed in silicone oil to avoid surface discharges. A CCD camera with a ×50 lens was used to capture electrical tree growth. An MPD 600 Omicron system was used to detect partial discharge activity during the growth of an electrical tree. The MPD 600 was connected to the MCU which is the transmitter between the MPD and the computer, and the signal is transferred via optic fiber. A CAL 542 was used regularly to calibrate both voltage and charge before any PD measurement. The schematic of the experimental set-up is described in Fig. 1.

In this study, three samples were tested under each of the following voltage waveforms as shown in Fig.2:

- 15 kV peak sine wave;
- 15 kV bipolar square wave;
- 15 kV square wave + 15 kV DC (positive unipolar square-wave switching between 0 kV and 30 kV);
- 15 kV square wave – 15 kV DC (negative unipolar square wave switching between 0 kV and -30 kV).

The frequency was 50 Hz for all tested samples. The rise-time of the square-wave voltage was 100 μs.

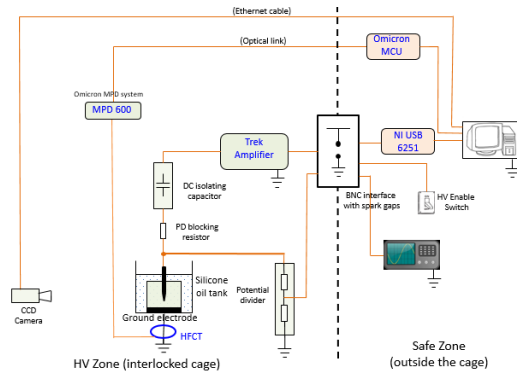

Figure 1. Schematic of experimental set-up for electrical treeing and partial discharge detection.

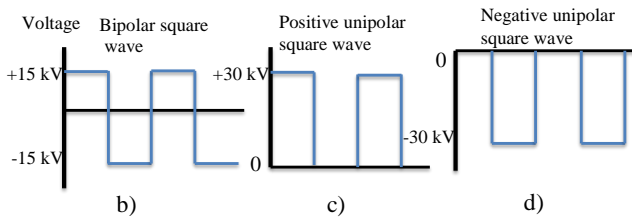

Figure 2. The square waveforms used in this study. These are labelled b), c), and d) in the text. The AC case (a) is not shown.

## III. RESULTS

### A. Electrical tree structure

Fig. 3 shows the typical structure of electrical tree growth for each applied voltage 10 minutes after tree initiation. Without DC bias, Fig. 3(a) shows the growth under a sine wave at 15 kV pk, while Fig 3(b) shows the growth under a 15 kV bipolar square wave. In Fig. 3(a) a small somewhat bush-like tree has formed close to the needle tip. Fine trees have extended from this small bush tree across the insulation towards the ground. In Fig. 3(b), a bush tree structure has formed around the needle tip and dark tree channels have extended from the bushy region towards the ground.

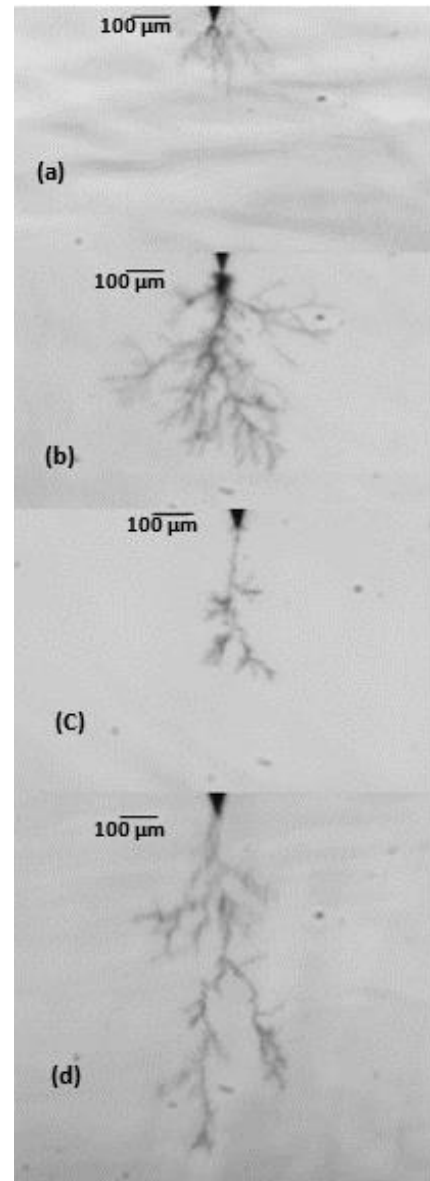

Figure 3. Electrical tree structure at 10 min after tree initiation, trees are grown under: (a) 15 kV sine wave, (b) 15 kV bipolar square wave, (c) -15 kV unipolar square wave, (d) +15 kV unipolar square wave.

The electrical tree grown under the bipolar square-wave in Fig. 3(b) has more and longer branches compared to the tree formed under a sine wave seen in Fig. 3(a). With DC bias, the growth of electrical trees under negative unipolar square waves and positive square waves are shown in Fig. 3(c) and Fig. 3(d) respectively. The tree shapes under negative and positive unipolar square-wave voltages are branch-like trees. However, the tree under the negative unipolar square wave has less branching and is narrower in shape in comparison with the electrical tree under positive unipolar square wave. Electrical tree shapes under positive and negative unipolar square wave are both narrower than the tree shape under the bipolar square wave at the same voltage.

### B. Electrical tree growth rate

The average electrical tree length under a 15 kV pk sine wave, 15 kV bipolar square wave, negative 15 kV unipolar square wave, and positive 15 kV unipolar square wave as a function of time from the 3 samples under each condition are shown in Fig 4. As seen in Fig 4, the electrical trees tend to grow faster under the bipolar square wave compared to the 15 kV sine wave cases. Electrical tree growth rates under negative square wave were lower than under the positive square wave, but the growth rate under both positive and negative unipolar square waves was higher in comparison with sine wave and bipolar square waves.

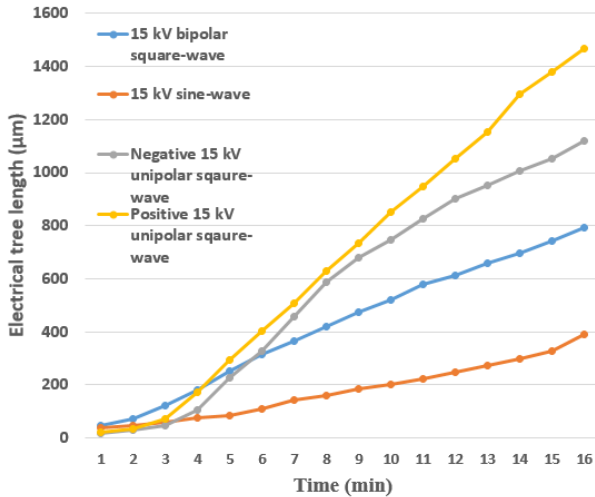

Figure 4. Electrical tree length as a function of time.

### C. Partial discharge activity

Fig. 5 shows partial discharge activity and corresponding electrical tree images from the first 5 min after tree initiation. Fig. 5 (a) shows a tree grown under the sine wave. The magnitude of the PD was  $\sim 9$  pC during the small bush tree initiation, followed by growth of fine tree channels. During the growth of the fine tree channels, there was no PD detected for about 20 min which is typical behavior under AC sine waves. Fine trees have previously been shown to yield no PD activity above 0.5 pC [5] and the minimum PD detection for the measurement system used here is 3 pC. Fig. 5(b) shows that the magnitude of the average apparent discharges was  $\sim 45$  pC

during the bush tree initiation under 15 kV bipolar square wave. The dark tree in Fig.5(b) extended from the bush tree for about 25 min with similar PD magnitudes; followed by reduction of PD activity for  $\sim 6$  min. Fig. 5(c) shows the PD activity during the initiation and growth of the dark tree under the -15 kV unipolar square wave. The peak PD during the initiation of the dark tree was  $\sim 38$  pC which reduced during the growth to  $\sim 20$  pC for about 13 min. A dark tree and corresponding PD under +15 kV unipolar square wave are shown in Fig. 5(d). The PD during the initiation of the dark tree was  $\sim 42$  pC followed by a reduction in PD magnitudes below  $\sim 23$  pC for 10 min. The PRPD patterns change when the nature of electrical tree changes from bush tree to branch tree.

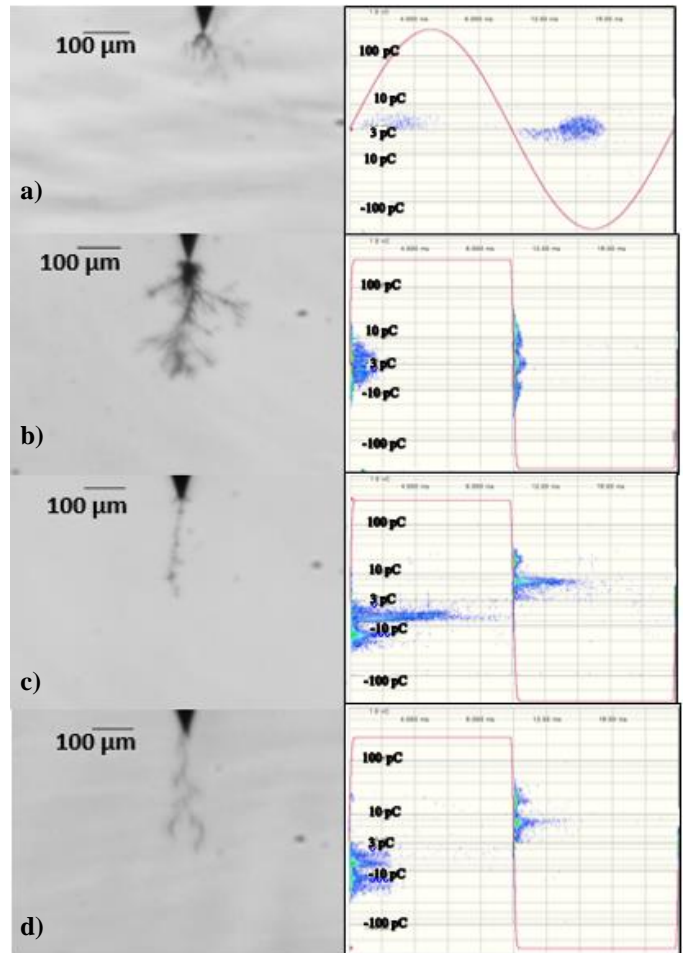

Figure 5. Tree imaging and corresponding PD patterns from trees grown after 5 minutes under a) sine wave, b) bipolar square wave, c) negative polarity square wave, d) positive polarity square wave.

## III. DISCUSSION

This work has shown that the growth rate and structure of electrical trees change with voltage waveforms and polarities. As shown in Fig. 3 and Fig. 4, tree structures under bipolar square-wave voltages differ from tree structures under sine-wave voltages. The tree shape under a bipolar square wave is

longer, darker and thicker in comparison with trees grown under sine-wave voltages. Tree growth was found to be significantly quicker when square-wave voltages were applied. A similar result was found by Wang et al [4] who noted that the square-wave voltage is more severe than a sinusoidal voltage at the same applied peak voltage. The influence of polarity and DC offsets have also been studied here. Both trees under negative and positive unipolar square-wave voltages were branch-like but the tree shape under negative unipolar square wave was less branched and narrower in shape.

Trees under both negative and positive unipolar square-wave voltages grow quicker than trees under bipolar square-wave voltages. This is probably because the absolute voltage applied across the sample is larger in these cases.

The tree structure under bipolar square-wave voltages was more of a bush-branch tree and is clearly distinct from the tree structure under both negative and positive unipolar square waves. Electrical trees grew faster under positive unipolar square waves than negative unipolar square waves at the same voltages. Similar results of the influence of positive and negative DC bias can also be found in [7]. Electrical tree length increased linearly with time under square-wave voltages and this result is in accordance with [8]. Electrical trees under 15 kV bipolar square wave reached the ground at 25-30 min after the tree initiation and some samples might breakdown even before that.

The difference between polarities is expected since a negative needle is expected to inject space charge (electrons) much more efficiently than their extraction when the needle is positive. The positive polarity therefore does not ameliorate the high field at the needle tip as readily as a negative polarity does [9].

Trends and magnitudes of the PD depend on the structure of the individual electrical tree [5] and the voltage waveform as shown in Fig. 5. For example, partial discharge corresponding to the initiation of the small bush trees and disappeared during the initiation and growth of fine trees. High PD magnitudes were commonly recorded around the polarity reversal of a square wave after 5 min of tree initiation in case of bipolar and unipolar square waves. The activity of the PDs was usually seen to reduce during growth of electrical tree under unipolar square-wave voltage and bipolar square-wave voltage.

#### IV. CONCLUSION

Electrical tree growth and associated partial discharge behavior under sine wave, bipolar square wave and unipolar square waves are reported in this work. Tree growth rates under bipolar square-wave voltages are faster than sine-wave voltages at same peak voltage levels. Tree shapes under bipolar square waves, with the same peak-to-peak voltage were darker and thicker than under sine-wave voltages. The growth rate under positive unipolar square wave was quicker than under negative unipolar square waves. The tree shapes grown under positive and negative unipolar square-wave voltages are branch-like while the tree in the bipolar square-wave voltages was bushier in shape. Both bipolar and unipolar

square-wave voltages resulted in higher PD activity after 5 minutes from tree initiation but the PD reduced during tree growth.

#### ACKNOWLEDGMENT

Aldawsari is grateful and thankful to Prince Sattam bin Abdulaziz University and Saudi Cultural bureau for financial support. The authors thank EPSRC for the support of this work through the project DC Networks, Power Quality and Plant Reliability, EP/T001232/1.

For the purpose of open access, the authors have applied a Creative Commons Attribution (CC BY) licence to any Author Accepted Manuscript version arising.

#### REFERENCES

- [1] A. Cavallini, D. Fabiani and G. C. Montanari, "Power electronics and electrical insulation systems - part 2: life modeling for insulation design" in *IEEE Electrical Insulation Magazine*, vol. 26, no. 4, pp. 33-39, July-Aug, 2010.
- [2] S. M. Rowland, R. Schurch, M. Pattouras, and Q. Li, "Application of FEA to image-based models of electrical trees with uniform conductivity" *IEEE Transactions on Dielectrics and Electrical Insulation*, vol. 22, no. 3, pp. 1537-1546, 2015.
- [3] H. Fu, C. Zhang, J. Xiang, Z. Cheng, S. Wang and J. Li, "Electrical Tree Characteristics of Epoxy Resin under Bipolar Square Wave Voltage" *IEEE International Conference on Dielectrics (ICD)*, 2020, pp. 142-145.
- [4] P. Wang et al., "Effects of bipolar repetitive square wave voltage parameters on electrical tree characteristics of epoxy resin" *Polymer Testing*, vol. 103, p. 107371, 2021.
- [5] I. Idrissu, S. M. Rowland, H. Zheng, Z. Lv and R. Schurch, "Electrical tree growth and partial discharge in epoxy resin under combined AC and DC voltage waveforms" *IEEE Transactions on Dielectrics and Electrical Insulation*, vol. 25, no. 6, pp. 2183-2190, 2018.
- [6] H. Zheng, G. Chen, and S. M. Rowland, "The influence of AC and DC voltages on electrical treeing in low density polyethylene" *International Journal of Electrical Power and Energy Systems*, vol. 114, p. 105386, 2020.
- [7] M. Liu, Y. Liu, Y. Li, P. Zheng and H. Rui, "Growth and partial discharge characteristics of electrical tree in XLPE under AC-DC composite voltage" *IEEE Transactions on Dielectrics and Electrical Insulation*, vol. 24, no. 4, pp. 2282-2290, 2017.
- [8] H. Fu, C. Zhang, J. Xiang, Z. Cheng, S. Wang and J. Li, "Electrical Tree Characteristics of Epoxy Resin under Bipolar Square Wave Voltage," *IEEE International Conference on Dielectrics (ICD)*, 2020, pp. 142-145.
- [9] I. Idrissu, H. Zheng, S. M. Rowland, "Electrical tree growth in epoxy resin under DC voltages" *IEEE International Conference on Dielectrics (ICD)*, 2016, pp. 820 - 823.