

Review

# Electrification of Compact Off-Highway Vehicles—Overview of the Current State of the Art and Trends

Daniele Beltrami <sup>1</sup>, Paolo Iora <sup>1</sup>, Laura Tribioli <sup>2</sup> and Stefano Uberti <sup>1,\*</sup>

<sup>1</sup> Department of Mechanical and Industrial Engineering, Università di Brescia, 25123 Brescia, Italy; d.beltrami002@unibs.it (D.B.); paolo.iora@unibs.it (P.I.)

<sup>2</sup> Department of Industrial Engineering, Università di Roma Niccolò Cusano, 00166 Roma, Italy; laura.tribioli@unicusano.it

\* Correspondence: stefano.uberti@unibs.it; Tel.: +39-030-3715517

**Abstract:** Electrified vehicles have undergone great evolution during the last decade because of the increasing attention paid on environmental sustainability, greenhouse gas emissions and air pollution. Emission regulations are becoming increasingly tight, and governments have been allocating multiple funds to facilitate the spreading of the so-called green mobility. In this context, steering towards electrified solutions not only for passenger vehicles, but also for compact off-highway vehicles extensively employed, for instance, on construction sites located in urban areas, warehouses, and greenhouses, is essential even if seldom considered. Moreover, the electrification of compact off-highway machinery may allow manufacturers to increase their expertise in and lower the costs of these alternative solutions, while gathering useful data to be applied in bigger and more remunerative off-highway vehicles. In fact, while electric automobiles are as of now real alternatives for buyers, off-highway vehicles, regardless of the application, are mostly in the research and experimental phase, with few of them already on the market. This delay, in comparison with the passenger automotive industry, is caused by different factors, mostly related to the different tasks of off-highway vehicles in terms of duty cycles, productivity performance parameters and user acceptability. The aim of this paper is to give an overview of the many aspects of the electrification of compact off-highway vehicles, to highlight the key differences between on-highway and off-highway vehicles and to summarize in a single source of information the multiple solutions investigated by researchers and manufacturers.

**Keywords:** electrification; green mobility; compact off-highway vehicles; battery electric



**Citation:** Beltrami, D.; Iora, P.; Tribioli, L.; Uberti, S. Electrification of Compact Off-Highway Vehicles—Overview of the Current State of the Art and Trends. *Energies* **2021**, *14*, 5565. <https://doi.org/10.3390/en14175565>

Academic Editors: Kwok Tong Chau and Rui Xiong

Received: 27 May 2021

Accepted: 27 August 2021

Published: 6 September 2021

**Publisher's Note:** MDPI stays neutral with regard to jurisdictional claims in published maps and institutional affiliations.



**Copyright:** © 2021 by the authors. Licensee MDPI, Basel, Switzerland. This article is an open access article distributed under the terms and conditions of the Creative Commons Attribution (CC BY) license (<https://creativecommons.org/licenses/by/4.0/>).

## 1. Introduction

The attention directed toward environmental sustainability has undergone a great increase in recent years, with the authorities pushing more and more towards a cleaner and more efficient usage of energy. In this context, the environmental impact of the transport and mobility sector is a very relevant topic all around the world: in Europe, for instance, the European Green Deal [1] aims for a 90% reduction in transport emissions by 2050. To reach the climate neutrality, new vehicle concepts, such as electric and hybrid vehicles, are believed to be essential [2] and the International Energy Agency (IEA) foresees a growth in the market share of electric vehicles (EVs) from 5 million in 2018 to 130–250 million by 2030 [3]. According to a European report on sustainable economy [4], 75% of European citizens live inside urban areas, meaning that the so-called “smart cities” are going to be the centers of innovation in mobility; as a consequence, compact electric vehicles are crucial, because they are more suited to urban environments. Additionally, compact machinery that work in very limited areas (construction sites, warehouses, greenhouses) can benefit significantly from full electric powertrain [5].

The automotive supply chain has been addressing the process of electrification for more than a decade, and now there are many feasible alternatives to the internal combustion engine (ICE) vehicles; at the same time, this growth is also pushing the off-highway vehicle

industry to accelerate its progress in the same process. In this regard, off-highway vehicles are an important source of emissions and fuel consumption [6], and, both in Europe and in the United States, authorities have been tightening the emission standards for non-road vehicles and machinery with the “TIER 1 . . . 4” [7] and the “STAGE I . . . V” classes [8]; because of these, it is predicted that, sooner or later, ICE-based vehicles could become more expensive than electric and hybrid ones [9].

While environmental concerns regarding air pollution and greenhouse gas emissions are the main drivers for the electrification process of the automotive industry, for the off-highway machinery industry, this process is strictly connected to other major drivers [10]: fuel economy, increased productivity and greater reliability.

Furthermore, while in a passenger vehicle, the power load is mainly related to traction [11], off-highway vehicles have a more complex load profile that is highly dependent on the mission of the vehicle and which is also related to different loads other than traction [12], such as hydraulic systems, ancillaries, etc. This implies important differences between automotive drive cycles and off-highway duty cycles, where the power requirements of hydraulic systems, ancillaries, implements and so on are major variables, highly fluctuating over a mission profile [13]. For this reason, the off-highway industry is investigating electrification to improve ancillaries and implements, too, in order to achieve lower operating costs, better control systems and new design possibilities [14].

To give a comprehensive overview of the state of the art, attention is firstly focused on the four main categories of the off-highway industry; then, the essential difference between automotive drive cycles and off-highway duty cycles is clarified. A brief overview on the main components of electric vehicles, i.e., batteries and motors, is provided before the in-depth analysis of the state of the art, where the major trends and requirements are investigated from a novel viewpoint focusing on the most developed off-highway category, namely the construction category. Before presenting the analysis of the possibilities for efficiency enhancements with respect to hydraulic and energy recovery systems, a list of some interesting compact electric vehicles is provided for each off-highway category. Lastly, a very brief outline of existing hybrid vehicles for these applications is presented, highlighting some of the differences between pure electric and hybrid solutions.

Therefore, this review aims to summarize the main topics surrounding the electrification of compact off-highway vehicles and machinery, highlighting which components or technologies are more suited for the compact segment of the industry, while also aiming to show how important compact machinery are and can be for the electrification of the whole industry; indeed, the authors believe that the compact segment is sometimes underestimated and, as far as the authors know, this is the first comprehensive review with a specific focus on the components that best suit these types of machinery. Furthermore, on the basis of a market analysis, we aim to show the actual trends in both the research and the industrial fields, providing the reader with a forecast about what to expect in the next few years.

## 2. Off-Highway Vehicles' Categories

The key aspect in the off-highway vehicles industry is that every vehicle is designed in order to complete its specific duty, based on intensive application within its specific operating environment [15]. As a result, there are many vehicles of different weight, power, layout, etc., that are tailored for specific duties, and the evaluation of the electrification possibilities for such vehicles is challenging because of this extensive diversity.

For the sake of simplicity, off-highway vehicles can be grouped into four main categories, as shown in the Table 1. Even if these different categories are universally recognized within the industry, there are instances of multipurpose vehicles that can be fitted with different accessories in order to fulfill duties across the board, e.g., small tractors that can be used during winter as snow removal machinery, or municipal and property maintenance vehicles with many different type of equipment.

**Table 1.** Off-highway vehicle categories.

Category	Vehicle
Tractors and agricultural.	Tractors, combine harvesters, field choppers, etc.
Municipal and property maintenance.	Turf cutters, street sweeping machines, etc.
Transportation of goods and material handling.	Forklift machines, material handlers, etc.
Construction, forestry and mining.	Excavators, frontend loaders, backhoes, etc.

### 3. Duty Cycles

Among the many different car-related drive cycles, the two most widely known ones are the New European Driving Cycle (NEDC) and the World harmonized Light-duty vehicles Test Procedure (WLTP) (Figure 1), which is the current standard for the evaluation of the fuel consumption and exhausts type approval tests.

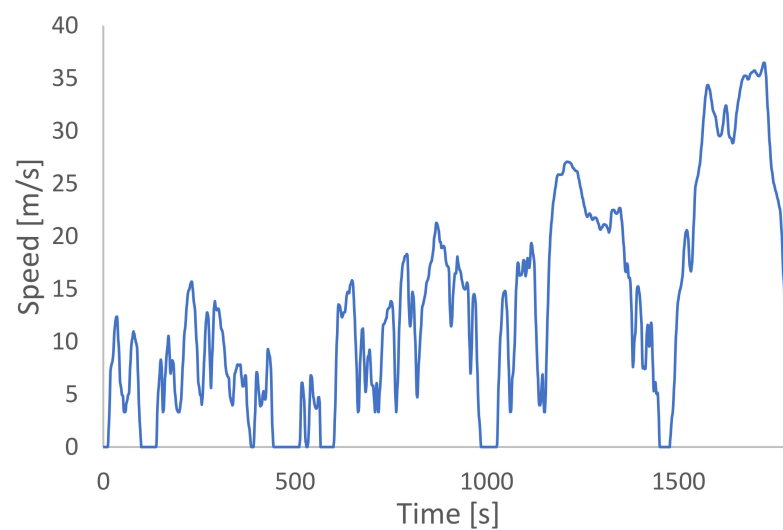
**Figure 1.** WLTP Drive cycle for passenger vehicles.

As can be seen in Figure 1, where the WLTP cycle is shown, typical automotive drive-cycles are based mainly on the speed profile, since the main power request source in passenger cars is the traction power, which is assumed to always be satisfied by the engine. Furthermore, any automobile manufacturer must test any new vehicle under the WLTP drive cycle before putting it on the market, and consequently all manufacturer information on fuel consumption is based on it. There are also many other standard drive cycles, but they are used mainly for engineering purposes, meaning that they are used during the vehicle design and verification phase, and they are not aimed at any certification process.

On the other hand, duty cycles for the off-highway industry must take into account different additional aspects: first of all, regardless of the vehicle under analysis, the duty cycle is much more intense in terms of magnitude and frequency of power peaks, as visible in Figure 2, which shows an example of drive mission for an agricultural tractor [13]; secondly, as of now, these standard duty cycles are used only for internal engineering and testing purposes, and they are not assumed to be a common basis among manufacturers. In these circumstances, every Original Equipment Manufacturer (OEM) is accustomed to its internal duty cycles and researchers even tend to register specific duty cycles for each vehicle under analysis.

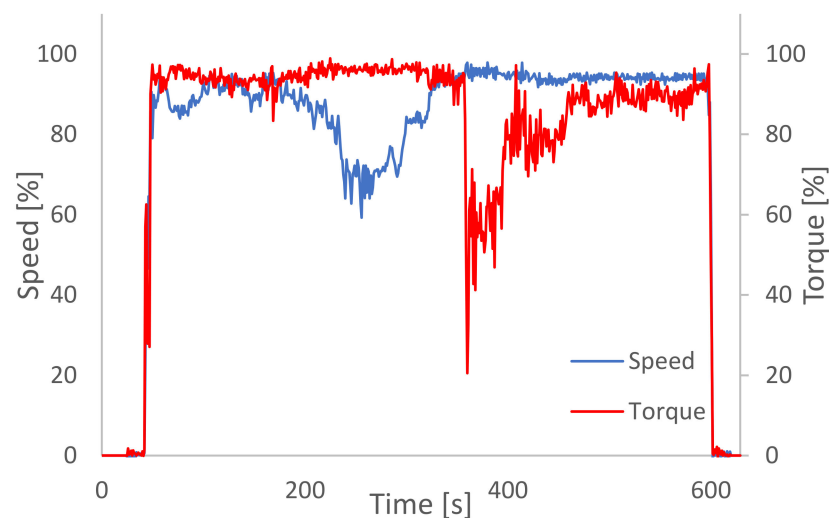

**Figure 2.** AG Tract Drive cycle for agricultural tractor.

As previously stated, the power flow in off-highway vehicles is not directed completely to traction, but rather is variably divided into different power outputs related to mechanical or hydraulic loads. Therefore, the definition of a typical duty cycle is also a huge challenge among vehicles that are similar.

To the best of authors' knowledge, the only known exception is the DLG Power Mix (Deutsche Landwirtschafts Gesellschaft-German Agricultural Society) [16], which states itself as the de facto standard for agriculture tractors, but it has no legal value for the homologation process, and it is mainly used to provide product information to potential buyers. In this regard, Refs. [17–19] investigated the electrification of agricultural tractors, but each one used different duty cycles, without mentioning anything about the DLG Power Mix or the AG Tract Drive cycle (Figure 2).

The same happens in the case of construction vehicles: in [20,21] the authors defined a specific duty cycle for the hybridization process of a skid loader, while in [22–26] different duty cycles were used for analyses on compact excavators. The need of a standard duty cycle for excavators has been emphasized in many articles, such as [27], and a good attempt at standardization was made by the Japanese Construction Mechanization Association with the test procedure explained in [28], but they are still not globally recognized.

As a matter of fact, duty cycles are key points for the electrification design process, since knowing the power and torque request profiles for each vehicle allows the correct selection and sizing of the on-board power sources, powertrain layout and energy storage systems. The final aim of the cycle analysis is the model-based simulation for energy consumption and working range estimation.

Operational runtime is another essential point for the electrification process, because many off-highway vehicles need to be continuously operative for eight or more hours, with very little or even no time for recharging during the day. Thus, the computation of working range and, eventually, elapsed charging time are essential parameters for boosting scheduling at building sites, warehouses, logistic and industrial plants, and so on.

#### 4. Main Components and Architectures of Electric Vehicles

Similarly to what is reported in [29], electric off-highway vehicles can be divided on the basis of their architectures:

- tethered type: these need constant physical connection to an external electric source; this can be the power grid or an external electric generator.
- battery type: these work completely disconnected from any external power source, which is needed only to recharge the internal energy storage system when the vehicle is not in use.
- tethered-battery type: there is the possibility of using the vehicle even during charging.

All these architectures are useful for specific applications and have been investigated during the last decade. For instance, extremely large excavators can exploit the boost in efficiency given by electrification [30], but to supply enough power to their systems, they require a physical connection to the power grid. Similarly, articulated loaders for underground mining have been electrified for many years, and they are already widespread in the market because of the primary need to not pollute underground air, but the majority of them are constantly connected to the power grid due to their very high energy demand [31]. Tethered-battery vehicles can overcome their limited range by connecting them to a set of overhead lines, like trolleybuses do [32], or to an external diesel generator only when needed, but this second solution is not ideal because it does not eliminate local air pollution and noise. Therefore, especially for compact electric vehicles, the most interesting architecture is the battery-type, as their operation is not limited by any electric cables.

Because of the high complexity of the drivetrain, the need for optimizing the efficiency, and the inherent flexibility provided by electrification, architectures with multiple electric motors are an important subject of research. In fact, while thermal engines usually require mechanical devices and/or hydraulic systems to transfer power, electric motors can be distributed differently on the vehicle platform. For instance, the automotive industry is looking at the optimization of weight distribution, the possibility of exploiting the benefit of torque vectoring and the enhancement of efficiency by cleverly combining speed and torque from different motors [33]. The benefits for the off-highway industry are even more profound. Indeed, depending on the mission, it could be useful to enhance the traction by using multiple motors on each axle [12], to move implements and ancillaries independently from one to the other [34,35], or to better control the speed of hydraulic pumps [36].

Thus, it is important to briefly analyze two of the main components of any battery electric vehicle: the energy storage system and the electric motor.

#### 4.1. Energy Storage Systems

The energy storage system is a key element for any electric vehicle. The main properties of any energy storage system are: specific power (W/kg), specific energy (Wh/kg), energy density (Wh/L), cycle life, and efficiency [11]. Thus, the choice of the energy storage is a combination of many aspects of the vehicle and its mission. In Table 2, a comparison between the most common energy storage systems [11,37] of the off-highway industry is provided.

**Table 2.** Comparison between the main energy storage systems [11,37].

	<b>Flywheel</b>	<b>Supercapacitor</b>	<b>Hydraulic Accumulator</b>	<b>Lead-Acid Battery</b>	<b>Ni-MH Battery</b>	<b>Lithium Battery</b>
Specific power (W/kg)	400–1500	500–5000	2000–19,000	75–300	150–200	250–340
Specific energy (Wh/kg)	10–30	2.5–5.5	2	30–50	60–120	75–200
Energy density (Wh/L)	20–80	35	5	50–80	150–180	200–250
Cycles	20,000	100,000	100,000	500–1500	2500	2000–10,000
Efficiency (%)	<96	<95	<90	<80	<90	<95

Among the different types of batteries, lithium batteries are recognized as the present state of the art, and also as the most interesting long-term solution, both from a technical and a cost-performance points of view; indeed, from 2010 to 2016, specific cost per energy unit (\$/kWh) decreased at a rate of almost 20% per year [38], while different combinations of cathode, anode and dielectric have entered the market. In this regard, while the automotive industry uses different chemistries such as LiFePO<sub>4</sub> (Lithium Iron Phosphate), NCA (Lithium Nickel Cobalt Aluminum Oxide) and NMC (Lithium Nickel Manganese

Cobalt Oxide) [39], in the off-highway industry, LiFePO<sub>4</sub> chemistry stands out as the de facto standard thanks to its inherent better safety and thermal stability [40].

Flywheels, supercapacitors and hydraulic accumulators have higher power density than batteries, but they are lacking in energy density, and this makes them more suitable for hybrid architectures, where the main energy source remains the ICE and the energy storage systems are used to follow the power peaks without excessively ramping up the ICE [41], and/or to accumulate energy from the recovery systems. Hydraulic accumulators in particular have extremely high specific power, but they also have the worst energy density, making them more difficult to implement in compact vehicles [42].

To improve the overall efficiency, researchers are focusing on the combination of more than one energy storage system [43–45]; consequently, it would be possible to take advantage of components with either high specific power or high specific energy.

#### 4.2. Electric Motors

Electric motors are the other fundamental components of electric vehicles: they convert electrical energy into mechanical energy, and they can also act as generators during regenerative events. Furthermore, their efficiency is higher than that of ICEs and, for limited periods of time, they can reach much greater peaks of power [46] (in some cases even two or more times higher than their target continuous power). In addition, thanks to their inherent characteristics and the use of an inverter, electric motors can supply the maximum available power along almost the entire velocity range [37], following an ideal curve for traction purposes.

Any electric motor to be implemented into a vehicle needs the following characteristics: mechanical ruggedness, high torque density, high energy efficiency, wide speed range, low noise, low or null maintenance, simple control and low cost [47].

The main properties of the three most common electric motors used in both the automotive and the off-highway industries are shown in Table 3 [29,37,47–49]; even if reported as macro-categories, they have their inherent advantages and disadvantages.

**Table 3.** Comparison between the main electric motors' technologies [29,37,47–50].

	<b>Induction Motor (IM)</b>	<b>Permanent Magnet Synchronous Motor (PMSM)</b>	<b>Switched Reluctance Motor (SRM)</b>
Advantages	Very robust Low cost Easy to control	High torque density Very high efficiency Good thermal	Good torque density Very robust Low cost
Disadvantages	Low efficiency Narrow speed range	High cost Magnets decay	Complex control Loud noise Big torque ripples

Induction Motors (IMs) and Permanent Magnet Synchronous Motors (PMSMs) are nowadays the most common electric motors in the automotive market [50]; PMSMs stand out in terms of torque density, being the best choice for high performance vehicles and for purely tractive efforts, while IMs are very robust, easy to control and, because of the absence of expensive permanent magnets, their cost is much lower, although they are bulkier and heavier.

To combine the best of these two technologies, in the last decade, many studies have been carried out on Switched Reluctance Motors (SRMs) [51,52]; the low-cost rotor in place of the more expensive permanent magnets and the higher efficiency in comparison with the IMs are the great advantages of the SRM motor. However, because of the highly complex control mechanism, they have been implemented on working prototypes only recently. Nonetheless, due to the promising cost/performance ratio, SRMs have been pointed out as the biggest future improvement in electric motors for both the on-highway and off-highway industries [53].



## 5. State of the Arts and Trends

To find the common trends of the electrification process within the off-highway vehicle industry, the authors believe that a market analysis focusing on the most developed category of the industry may be regarded as representative. Therefore, this paper focuses the market analysis on the construction vehicle category, in particular, the case of excavators and front-end loaders, as they are the two most common types [42]. It should be noted that while the data were collected from OEM websites, scientific papers, and trade magazines, they remain indicative values; when they were incomplete, they were consciously derived by the authors.

Figure 3 shows the ratio between the operative weight and ICE power of excavators, along with their electric counterparts, where EM continuous power is considered in place of ICE power; the linear regressions between the two are also reported. As can be seen, the power-to-weight ratio is almost identical, meaning that almost all the electric vehicles are designed by simply substituting the ICE with an electric motor of equivalent power (continuous mode). Things are different when considering the peak power of the electric motors. Indeed, in this case, as can be seen in Figure 4, the power-to-weight ratio of the electric excavator is constantly higher than the ICE-powered one. It should be noted that, in the case of peak power, the plot is restricted to smaller excavators because of the highly scattered data of the bigger ones.

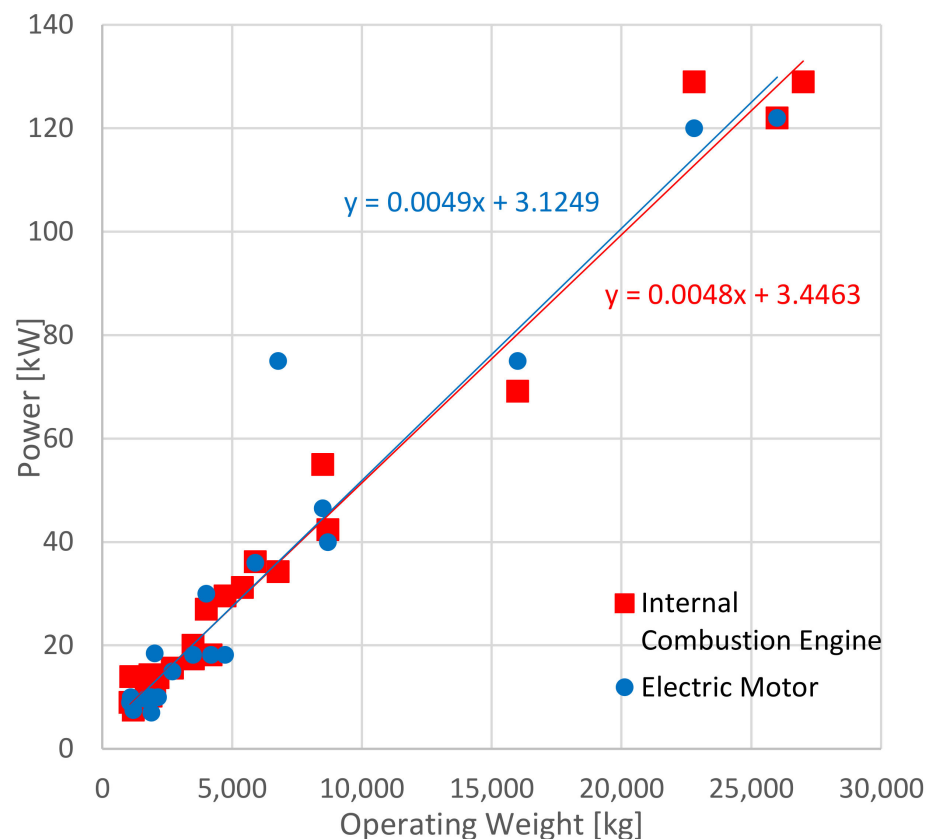

**Figure 3.** Power-to-weight ratio of ICE excavators and EM excavators (continuous power) with linear regressions.

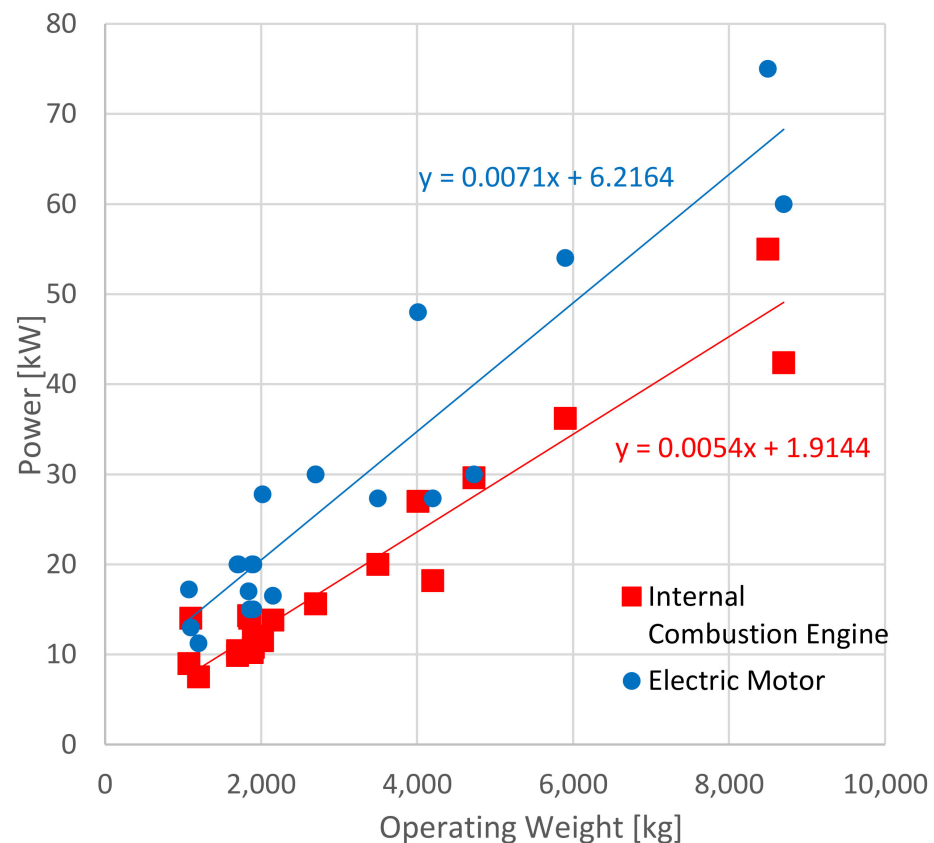

**Figure 4.** Power-to-weight ratio of ICE-powered excavators and EM-powered excavators (peak power) with linear regressions.

Another fundamental aspect visible in the plot is that the majority of the vehicles belong to the compact segment, characterized by a weight below 5000 kg and a maximum power of 30 kW. This is due to two key reasons: on the one hand, the electrification of compact vehicles is less expensive for manufacturers, providing the opportunity of having cost-efficient running vehicles, from which useful operating data can be collected for scaling up toward bigger and more remunerative vehicles [54]; on the other hand, the emission regulations and the increasing number of “zero-emission” city centers [55] makes electrification necessary for the compact class of excavators in the immediate future. In this regard, manufacturers like Volvo CE (Gothenburg, Sweden) and Wacker Neuson SE (Munich, Germany) are already conducting customer field tests on emission-free construction sites [56,57], while municipalities like Helsinki, Amsterdam, Brussels and others are exploring the possibility of limiting public construction tenders to free-emission vehicles and projects only [58].

In Figure 5, another interesting aspect of the electrification process is shown, which is the rather common choice of keeping the voltage below the high-voltage automotive limit of 60 V DC (Direct Current) [59], providing an advantage in terms of costs reduction. On the one hand, the low cost is made possible by the higher level of standardization of the components for systems below 60 V [60] (they have been used for decades on electric forklifts and they are currently used on most of the automotive hybrid systems, including start and stop systems), while on the other hand, above this limit, much more sophisticated, protective and reliable systems for preventing short-circuits are needed [61]. In this regard, the automotive industry is already moving towards high-voltage systems because of their inherent increased efficiency [62], while their higher costs are mitigated thanks to their suitability for mass production.

Regarding efficiency and energy consumption, it can be seen from Figure 6 that the operational runtimes of electric excavators are very scattered; the main reason for this is the



absence of a standard duty cycle commonly recognized by manufacturers. Therefore, many of the available data regarding running times are neither accurate nor validated. Even if there are scientific papers and published manufacturers' reports in which the operational runtimes are calculated by means of the published duty cycles, like the one by the Swiss manufacturer Suncar HK AG (Oberbüren, Switzerland) [24], these are barely comparable to the others.

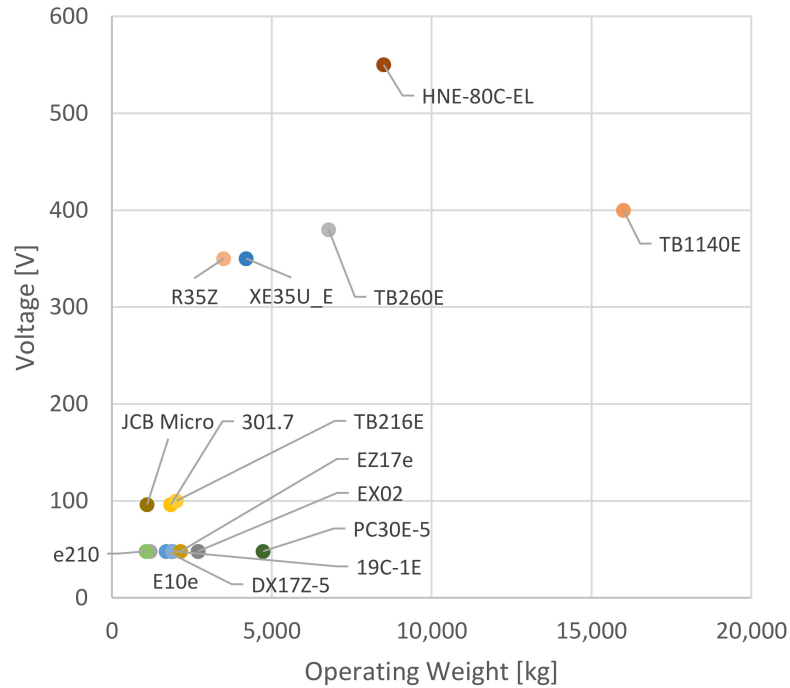

Figure 5. System voltage in relation to the operating weight. Labels refer to different excavator models according to manufacturers' datasheets.

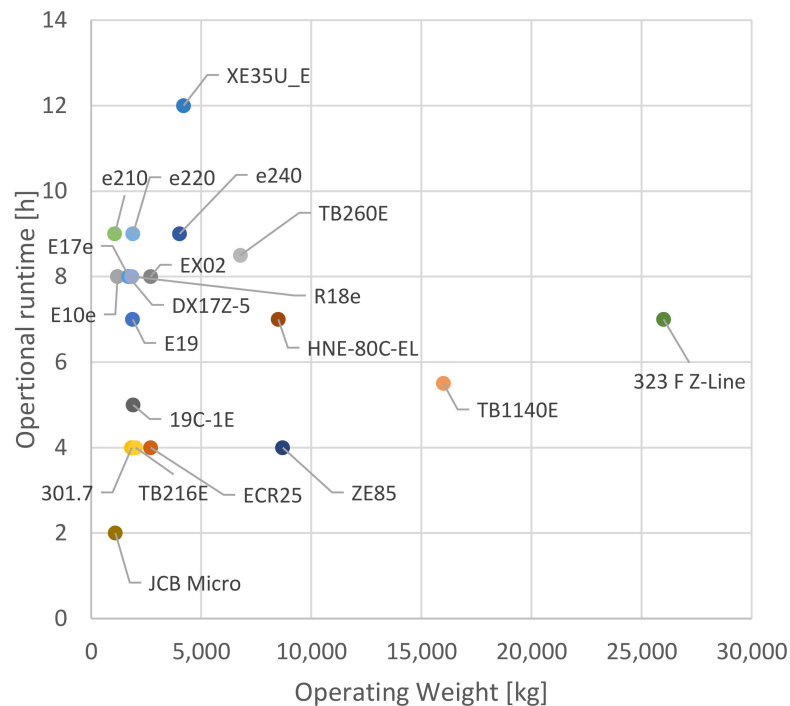
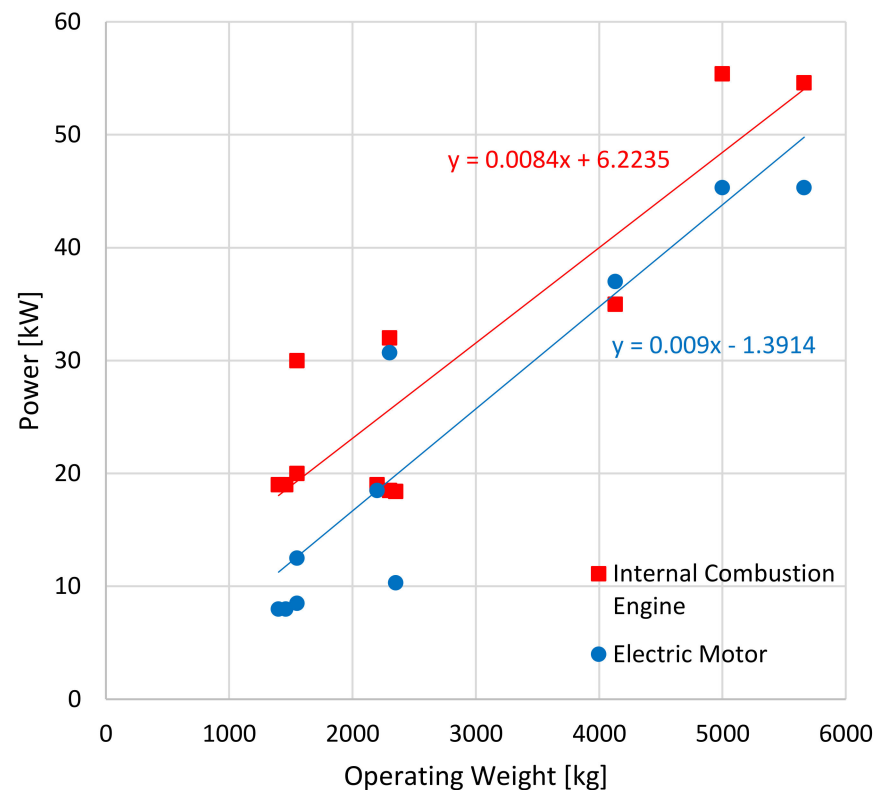

Figure 6. Operational runtime in relation to operating weight. Labels refer to different excavator models according to manufacturers' datasheets.

As a matter of fact, most of the electric excavators are retrofittings of existing ICE-powered vehicles, where the design efforts were limited to the integration of the electric motor, battery pack and charging system in place of the ICE and the fuel tank, with additional efforts devoted to the implementation of the control system for the new powertrain architectures.

The situation is similar for front-end loaders, as can be seen in Figure 7, even if there are some differences: first of all, the number of electric vehicles is much lower; secondly the data are much more scattered.



**Figure 7.** Power-to-weight ratio of ICE-powered loaders and EM-powered loaders (continuous power) with linear regressions.

Another relevant difference is related to the changes in the powertrain architectures adopted for the electric vehicles; for instance, in the majority of the front-end loaders, manufacturers prefer the adoption of two EMs instead of the single ICE (Figure 8), differentiating the power flow requested by traction from the power flow requested by hydraulic actuators and ancillaries. The typical mission of front-end loaders indeed requires great tractive effort, while excavators usually work at a fixed point, and consequently, the choice to double the motors allows a great improvement both in productivity and in efficiency. The results are visible in Figure 7, where it is clear that the continuous power of electric loaders is usually lower than the corresponding ICE-powered original versions.

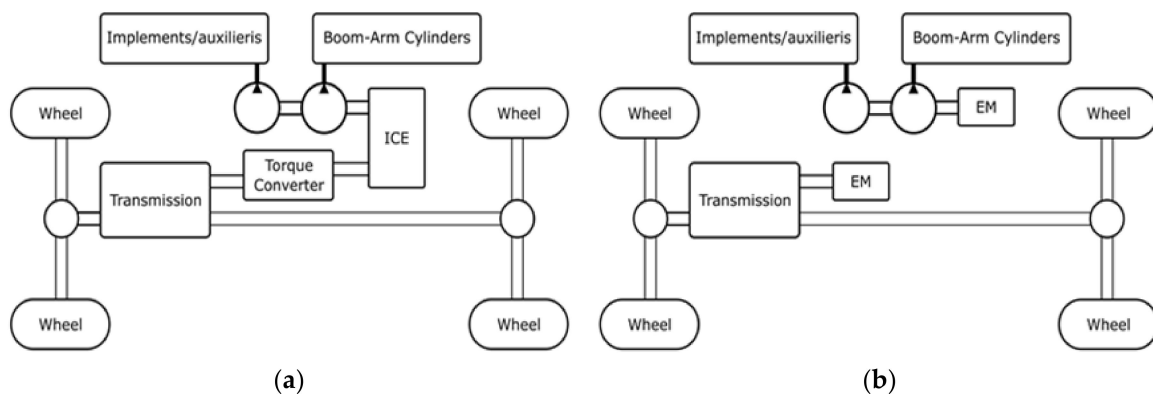

**Figure 8.** Simplified power scheme of a front-end loader. (a) ICE-powered loader. (b) EM-powered loader.

The lower number of electric front-end loaders can be justified by the higher cost of development, but, in the same way as for excavators, the greatest number of electric applications can be found within the compact segment, characterized, once again, by weight under 5000 kg and the power below 30 kW.

However, the common and most important aspect of the current electrification process is the attempt to maintain reasonable costs by limiting difficult innovations, developing retrofitted electric vehicles from existing ICE based ones and/or outsourcing much of the design process to more specialized and agile companies, such as Green Machine (Buffalo, NY, USA), who have played an extensive role in the electrification of many pieces of construction equipment from different manufacturers such as Case CE (Amsterdam, The Netherlands), Takeuchi Mfg (Sakaki, Japan) and Bobcat (West Fargo, ND, USA) [54].

In this scenario, predictions from Frost and Sullivan [63] foresee an increase of the battery electric compact excavator market share from the current 1% to 4% in 2030, as well as an increase in compact battery electric front-end loaders to 6% before 2030.

Regarding the other categories of off-highway vehicles and machineries, the number of electric products is much more limited; consequently, it is impossible to statistically verify the identified trends identified above. Nevertheless, picking some vehicles for any category, case-by-case they generally confirm these trends. For instance, the electric telehandler 525-60E by JCB [64], which is considered to be within both the construction and agricultural categories, has two electric motors (17 kW and 22 kW), and it follows the trend of the front-end loaders, since, due to a relatively better efficiency, its power-to-weight ratio is slightly lower than the ICE-based one. Still, with respect to agricultural machinery, in [65], the retrofiting of a 9.6-kW diesel tractor is presented, whereby the engine is replaced with a 10-kW electric motor, with a slightly higher operating weight. Lastly, in the mining category, the biggest battery electric vehicle is the Swiss e-dumper, retrofitted from a Komatsu HD-605 [66]; while the original version has a diesel engine of 578 kW, the electric one has a 673-kW motor, but, at the same time, the operating weight of the electric version is higher and the power-to-weight ratio remains similar.

In conclusion, it is worth mentioning that the trends cited above are in agreement with the electrification roadmap of some of the major Tier 1 companies, such as ZF Friedrichshafen AG (Friedrichshafen, Germany) [67], Bosch Rexroth AG (Rolf am Main, Germany) [68] and Deutz AG (Cologne, Germany) [69].

## 6. Relevant Off-Highway Electric Vehicles

In this paragraph, some compact off-highway vehicles are presented in order to give practical instances of existing electric and hybrid vehicles; while some of them are purely research projects or experimental prototypes, other are already available on the market.

It should be noted that, even if the focus is on compact machines, some very interesting non-compact vehicles are included to give a more complete overview.

### 6.1. Tractor and Agricultural Machinery

Within the category of tractors and agricultural machinery, electrification has been pointed out as the next important milestone [70], since the technology has almost reached its optimization limit, but the need for agricultural equipment is increasing due to global population growth. Market research reported in [9] states that the current electric solutions are sufficient only for a small niche of greenhouses and orchards.

Regarding the farm tractor market, the most interesting partition is determined on the basis of power output, which divides the tractors in three main categories: below 49 HP, between 50 HP and 79 HP, and above 80 HP [71]. For the purposes of this article, the most interesting projects are those below 79 HP, which can be defined as compact.

One of the most interesting compact electric project is the Fendt e100 Vario (Figure 9a) which is equipped with a 50-kW electric motor and a 100-kWh lithium battery at 400 V, with a stated working autonomy of 5 h and the possibility of restoring the battery state of charge (SOC) up to 80% in 40 min. Implements can be attached via traditional power take-offs (PTOs) or hydraulic, but there is also a 150-kW electric plug [72].



**Figure 9.** Electric tractor. (a) Fendt e100 Vario. (b) Rigitrac SKE 40. (c) Monarch MK4. [72–74].

Two other interesting electric projects are the Rigitrac SK-50 and SK-40 (Figure 9b). These are actually market products, and they are characterized by the use of five electric motors: two traction motors, one motor for each of the two power take-offs, and one motor for the hydraulic system. The operational runtime is stated to be about 5 h, with the possibility of rapid charging the battery to 80% SOC in 2 h [73].

Another very interesting project is the Monarch MK4 (Figure 9c), which is not only the first orchard and vineyard tractor of the Californian start-up company, but is also the first automated tractor available on the market. It has two 30-kW electric motors, one for traction and one for the PTO, and the company claims an operational runtime longer than 4 h, with the possibility of swapping the entire battery pack to rapidly come back to work instead of waiting for the complete charge, which takes more than 4 h at 220/240 V [74].

Lastly, the Farmtrac 25G is a 15-kW electric tractor [75]. It is commercially available, and, thanks to its 22-kWh NMC lithium battery, the operational runtime is stated to be about 8 h, with the charging time estimated to be close 5 h with a common domestic socket.

Among the electric agricultural vehicles that cannot be considered as compact, the concept machinery and working prototypes of John Deere (Moline, IL, USA) are surely worth mentioning; indeed, the John Deere SESAM (Sustainable Energy Supply for Agricultural Machinery) and the John Deere GridCON are testament to the interest of the company in researching novel approaches to face similar problems. The SESAM tractor is equipped with a 150-kWh battery pack for 1 h of intense work before recharging [76], while the GridCON is a tethered, fully autonomous and unmanned tractor equipped with a 100-kW electric motor for traction, and 200-kW electric motor directly connected to the PTO in order to transfer mechanical power to implements [77].

The last highly interesting agricultural vehicle is the E-OX 175 [78], which is the most recent development of the innovative Multi Tool Tractor, and it probably represents one of the most groundbreaking examples of how much electrification can transform the common architectures. Indeed, not only the traction is guaranteed by four wheel-drive electric motors, but it can also change its wheelbase and turning radius in order to optimize its use on fields without damaging the crop.

## 6.2. Municipal and Property Maintenance

The most important municipal and property maintenance vehicles are municipal vehicles and street sweepers, which are also among the most interesting vehicles for the electrification process due to their urban use, their highly fluctuating duty cycle, and the use of many different types of equipment for sweeping, cleaning and vacuuming. Furthermore, these vehicles usually work during the night, meaning that a reduction of the noise level is a very attractive feature, and finally, these are very interesting applications for the automation process.

In [79], a feasibility study is performed for an electric street sweeper, including the definition of a representative duty cycle, modeling of the vehicle, and the selection of suitable components for the powertrain and driveline. The simulated duty cycle results in an operational runtime below 5 h, where the cleaning equipment requires more than half of the gross power of the electric motor.

Dulevo International S.p.A. (Fontanellato, Italy), one of the leading companies in street sweeping vehicles and equipment, already offers an electric vehicle called Dulevo D.Zero<sup>2</sup> (Figure 10a), equipped with a lithium battery pack and capable of working for an entire work shift [80]; another instance is the Swiss Boschung Holding AG (Payerne, Switzerland), which has an electric street sweeper called the Urban-Sweeper S2 (Figure 10b), equipped with a 54.4-kWh battery capable of providing up to 10 h of autonomy with the possibility to fully charging the battery in 100 min thanks to the rapid charger [81].

In [82], an electric municipal vehicle by Esagono Energia S.r.l. (Pozzuolo Martesana, Italy) (Figure 10c) was used to validate a mathematical model able to predict with sufficient accuracy the working range of a L-7 vehicle, also taking into consideration the effect of slopes; the tested vehicle was equipped with a 15-kW induction motor, a LiFePO<sub>4</sub> battery of 15.3 kWh and it is available with many different types of equipment. Because of the aim of the paper and the equipment of the vehicle under testing, the duty cycle is a simple drive cycle, and it is registered via an experimental campaign; the working autonomy results were adequate for a complete work shift, but further investigations would be useful to predict the impact of different equipment on the same base model.

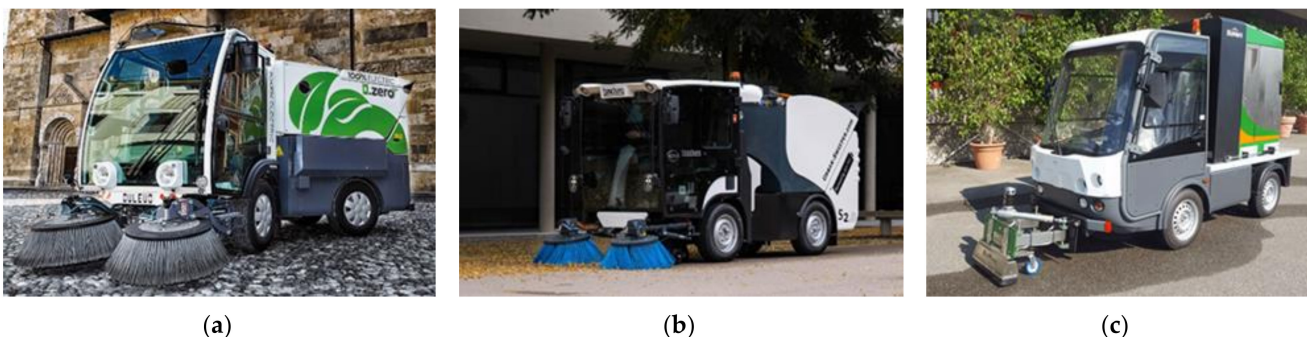

**Figure 10.** Electric maintain property vehicle. (a) Dulevo D.Zero2. (b) Boschung Urban-Sweeper S2. (c) Esagono Energia Gastone. [80,81,83].

Examples of non-compact vehicles are the electric refuse trucks that are entering the customer testing phase, like the ones used in Nottingham, where the City Council has declared that they are outperforming the ICE-powered counterparts, with lower fuel consumption and greater speed in completing the shift route [84].



### 6.3. Transportation of Goods and Material Handling

There are specific applications in which electric vehicles and machinery already represent a suitable and highly appreciated solution, such as in the case of forklifts, which are also the most widely known compact goods transportation vehicles. Indeed, electric forklifts were the first off-highway vehicles to be converted into electric ones and, as a consequence, they are currently very popular for the use inside warehouses, where the absence of exhaust gas emission and lower noise levels are considerable advantages and where the charging infrastructure is easily available. The technology is mature and competitive to such an extent that, according to Toyota Material Handling (Kariya, Japan) [85], even electric forklifts up to 9000 kg are gaining acceptance among consumers, and their upfront cost is only 10-15% higher than ICE-based counterparts. Consequently, all the major forklift manufacturers, such as Toyota Material Handling (Kariya, Japan), Hyster-Yale Materials Handling Inc. (Cleveland, OH, USA), KION Group AG (Frankfurt, Germany) and Jungheinrich AG (Hamburg, Germany) have a very large portfolio of electric forklifts with lead acid or lithium batteries (Figure 11a). Furthermore, it is worth mentioning that much of the current 48-V technology for the electrification of compact vehicles descends directly from the research on forklifts. Currently, forklifts remain among the most interesting vehicles for research and testing purposes, since their duty cycles can be easily monitored, and the available movements of their actuators are limited. For instance, in [86], the researchers investigated the application of two hydraulic motors to recover energy, while in [87,88], a powertrain based on fuel cells was analyzed.



**Figure 11.** Goods transportation and material handling vehicles. (a) Hyster-Yale forklift. (b) Simai towing tractor. (c) Sennebogen material handler. [89–91].

Other important compact material handling vehicles are the towing tractors, for which there is already a great number of electric vehicles due to their use in warehouses, production plants, ports and airports (Figure 11b). In all these cases, the routes are well defined, as well as the time-tables, and consequently, their use can be carefully planned in order to optimize their energy consumption and recharge times. Furthermore, electric powertrains are perfectly suited for these types of vehicles due to their typical high torque and low speed demands, with multiple speed variations that can be exploited to recover energy.

The last interesting vehicles in this category are the material handlers (Figure 11c). In this regard, tethered electric machines are used for very intensive use applications, while more compact battery electric ones are slowly entering the market; they are already suitable for less demanding applications and for use in cases where the cable connection could excessively limit the range of the machinery. However, one of the most advanced material handler is the prototype built by Dolomitech S.r.l. (Castel Ivano, Italy) and Moog Inc. (Elma, NY, USA) [92]: even if it cannot be considered as compact, being a 50-ton machinery, it is a battery electric vehicle with direct-driven hydraulics capable of optimizing energy consumption while guaranteeing the performance of an equivalent ICE-based counterpart. It currently represents the state of the art of electric material handlers, and its innovative hydraulic system is very interesting also for other off-highway vehicles.



#### 6.4. Construction and Mining

The construction equipment industry is the biggest category of off-highway vehicles and, as already mentioned in Section 5, is promising for the electrification process, especially in the case of compact machinery that can be used in urban construction sites or indoor environments. Indeed, both the market and the scientific literature have been experiencing a remarkable increase in retrofitted electric vehicles in recent years, particularly with respect to compact excavators.

For instance, JCB Ltd. (Rocester, England, UK) was one of the first manufacturers to enter the market with an electric construction vehicle, and now it has many electric products for zero-emission construction sites under the JCB E-Tech brand, such as the compact excavator 19C-1E (Figure 12a), which is equipped with 19.8-kWh lithium battery and a 7-kW continuous power PMSM motor. This solution can exceed 4 h of continuous use, and also includes a proprietary rapid charge system able to reach 100% SOC in 2 h [93].

As already mentioned in Section 5, the second most common construction vehicle types are front-end loaders; a typical example of an electric compact loader is the Tobroco-Giant G2200E (Figure 12b), that is a four-wheel drive machinery with two different motors: a 6.5-kW (continuous power) motor for traction and a 12-kW motor for hydraulics. It is possible to choose between two lithium battery sizes, and the biggest one can store 24.9 kWh for an operational runtime up to 8 h [94].

Undoubtedly, one of the leading companies in the electrification process is Volvo (Gothenburg, Sweden) and within its very large portfolio of off-highway vehicles is the Volvo EX02 (Figure 12c), which is a full electric excavator equipped with electromechanical linear actuators and a 38-kWh lithium battery pack [95]. Being a testing prototype and a proof of concept, many technical details are unpublished, but Volvo claims a 10-fold fuel reduction with respect to its ICE-powered counterpart and a considerable decrease in total cost of ownership.

There are many other examples in the literature. For instance, in [23], a 2-ton electric excavator was modeled by means of Matlab/Simulink. The aim of the research was to create a model able to predict the operational runtime of the machine, and consequently much attention was given to the modeling the overall system, including hydraulics. The second purpose of the article was to develop a validated model to safely simulate new control strategies. Thanks to a 9.6-kW (continuous power) electric motor and a 15-kWh LiFePO<sub>4</sub> battery pack, the electric excavator retrofitted from a Bobcat E19 is able to reach up to 7 h of real working performance, and the power consumption is differentiated between excavation, relocation and travel. Another case that is worth mentioning is the compact excavator studied in [26], which has been used for multiple studies focused on electrification and hydraulics [96,97].



**Figure 12.** Electric construction vehicles. (a) JCB 19C-1E. (b) Tobroco-Giant E2200. (c) Volvo EX02. [98–100].

Regarding the mining sector, there are already many electric loaders that are very useful for reducing the air pollution issue at underground sites, but these are usually tethered machines, and they cannot be considered as compact. It is worth mentioning that,

more generally, compact vehicles are not suited for the mining industry. However, one innovative project is HX-02 load carrier studied by Volvo (Gothenburg, Sweden) and tested in the Swedish mining site Skanska: it is a battery electric, completely autonomous vehicle with a continuous power of 200 kW. Thanks to its implementation in more digitalized and automated mining sites, Volvo and Skanska state a reduction in total cost of operation of about 25%, with a CO<sub>2</sub> emission reduction of 95% [101].

## 7. Efficiency Enhancements

The focus on efficiency gains, power flows and, more generally, energy control strategies is a crucial point for the electric vehicles. Indeed, every waste of energy directly impacts the operational runtime and, accordingly, the battery pack, which is currently the most expensive component. While in ICE-powered vehicles the inefficiencies of the entire system are somehow negligible with respect to the even lower efficiency of the ICE, in electric vehicles, every waste of energy is much more relevant. In this regard, the two main possibilities for increasing the overall efficiency are the improvement and/or replacement of hydraulic systems, and the possibility of recovering energy. In the following, the different technologies are shown in a more comprehensive way, while in Tables 4 and 5, they are simply listed for the clarity of presentation.

### 7.1. Hydraulics Systems and Actuators

As previously stated in Section 5, many of the existing electric vehicles derive from existing ICE-based ones with only limited modification to the powertrain. Consequently, in most cases, the hydraulic systems remain almost unchanged. On the one hand, this choice allows operators to work as they are accustomed, with very little time required for adaptation to the different dynamic response of actuators imposed by the electric motor, while, on the other hand, it evidences the low efficiency of the current hydraulic systems.

As can be seen in Figure 13, in a conventional hydraulic system, the pump is mechanically coupled to the ICE, so the hydraulic power is strictly correlated with the ICE speed and torque; the higher the power requested by the load, the higher the corresponding speed of the ICE. Because of the combined lack of efficiency of both the ICE and hydraulic system, the net mechanical energy available is of about 25% at best, and even using an EM instead of an ICE, the maximum overall efficiency of the machinery increases to only 56% [102]. In [103] the energy flow of an excavator was analyzed in detail and it was shown that the actual energy to the final load was only the 26.6% of the hydraulic energy converted in the pump, confirming the rather low efficiency of the hydraulic system. Furthermore, in order to harness the benefits of electrification with respect to torque control, better dynamics, more accurate movements, and so on, standard hydraulic systems require the control of flow, pressure and direction, mainly by means of pressure drops, which can be regarded as intentional losses of energy [104]. Nonetheless, hydraulics is still considered essential in most off-highway vehicles and machinery due to its great power density; thus, its complete replacement is currently limited to niche products. In this scenario, research has been focused on two main strategies: reducing idle losses and lowering hydraulic ones [105].

Reducing idle losses, thanks to the inherent characteristics of electric motors, is the easiest and more cost-effective approach to save energy; the main idea is to lower the power output of the pump as soon as possible by limiting the swash displacement and/or controlling the pump speed. Even if the former is already very common across the industry, the control on the pump speed is something very difficult to achieve with ICEs, although it is easier to implement with electric motors. For instance, in [26], the researchers investigated the energy consumption of a micro-excavator retrofitted with an electric motor, in which the original fixed displacement pump was replaced with a variable displacement pump; the results showed great room for improvement and the main power losses were identified as occurring in the main directional valve group. In [106], a 6-ton electric excavator was simulated and tested in order to define the best strategy between the pure swash variable displacement strategy and the variable displacement and speed one; while the

former guarantees a maximum efficiency boost of about 10%, the second strategy allows an additional improvement of 28.5%. Still regarding idle losses, while all the ancillaries (cooling fans, heating ventilation and air conditioning system, etc.) are mechanically linked to the engine shaft in ICE-powered vehicles, with electric vehicles and machinery it is possible to use decentralized and much smaller electric drives, making them independent of one another and optimizing the speed range of each of them, with those that are not needed even being turned off. However, while the speed and displacement strategies are already of great interest for compact vehicles, since they do not require additional room, the application of decentralized drives requires a slightly new design of the vehicle architecture.

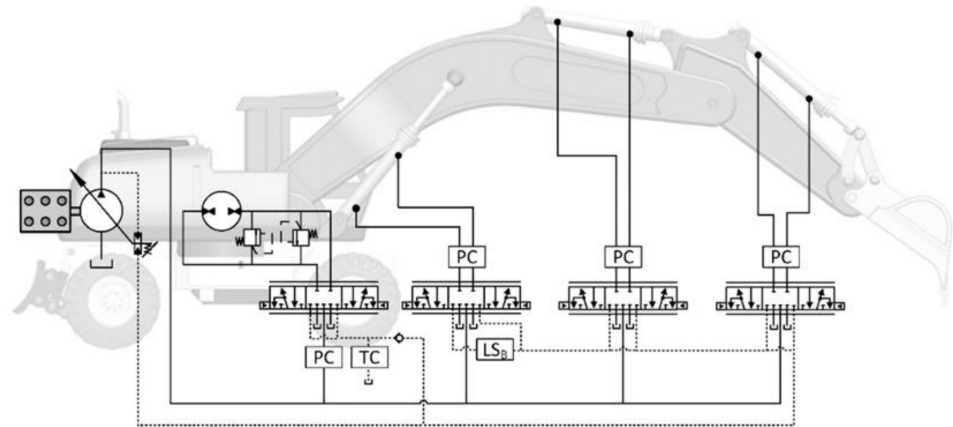

**Figure 13.** Hydraulic scheme of an ICE powered excavator. [105].

The other strategy, namely the reduction of hydraulic losses, requires many more changes in terms of hydraulics, as it requires the replacement of one or more components. In fact, the major loss is located in the main directional valve group, and consequently many researchers have investigated the of replacing this very common, reliable and easy-to-control component with Individual Metering Control systems (IMC). In [107], the researchers conducted a comparative simulation study on an ICE-equipped excavator, comparing the traditional valve group and an IMC system; the results revealed a foreseen energy-saving up to 44% due to a decrease in the power consumption of the pump. This type of hydraulics has already demonstrated its potential in ICE-powered vehicles, and it can greatly benefit from the more accurate control of EM over the pump rotor speed. Another possible and already under-study method for eliminating the main directional valve group is the replacement of the main pump with the so-called direct-driven-hydraulics (also known as electro-hydrostatic actuator technology), meaning that every actuator is moved by an independent pump and electric motor; consequently, this solution is suitable only for electric (or hybrid) machinery due to the need to distribute the power to the dislocated pumps. In [96,97] a compact electric excavator was used as a proof of concept for the testing of three independent direct-driven-actuators replacing the original hydraulic system, achieving an overall efficiency up to 73% (Figure 14). As already stated, these solutions for the reduction of hydraulic losses often require redesigning many parts of the vehicles, and therefore, they are not ideal for retrofitted ones, irrespective of the size of the vehicle. However, because of the room available on bigger machinery, considering their extensive use of hydraulic systems, the mentioned solutions are more suitable for mid to large off-highway vehicles.

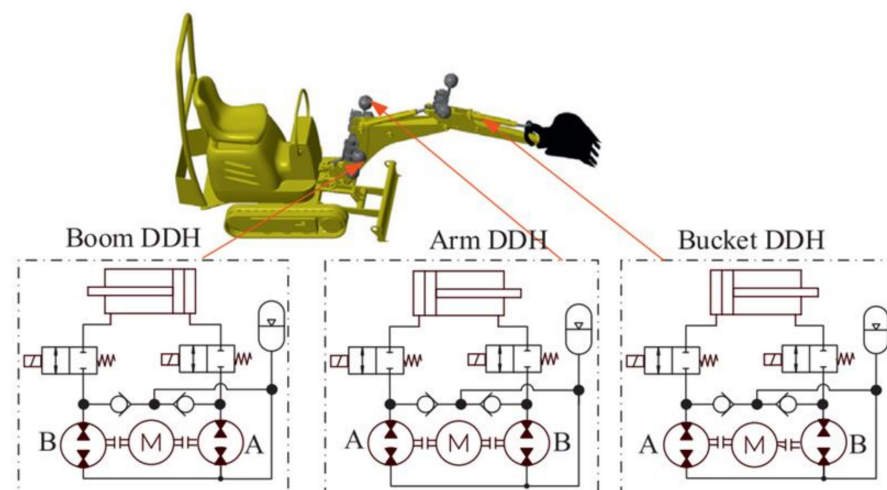

Figure 14. Direct-driven hydraulic scheme for a compact excavator. [97].

To increase the efficiency of the hydraulic system, there are also patented solutions that are undergoing testing by manufacturers (Table 4): one example is the Digital Displacement<sup>®</sup> Pump by Danfoss (Nordborg, Denmark) [108], which makes it possible to operate multiple actuators simultaneously by setting independent pressures and flows for each of them, allowing for a stated fuel reduction of more than 30%. A second interesting example, funded by European funds Horizon 2020 [109], is the multi-chamber actuators technology from Norrhydro (Rovaniemi, Finland), known as NorrDigi<sup>™</sup>, which claims an efficiency increase up to 50% [110].

The more drastic approach to increase the efficiency is the replacement of as many hydraulic actuators as possible with electro-mechanical actuators (EMAs), following the trend already taking place in the aviation industry [111]. Even if it is currently restricted for niche products, this strategy could be considered as the final goal of the electrification process. Indeed, power-by-wire actuators would guarantee optimal efficiency, easier and more precise control, easier maintenance, better diagnostic and, above all, the possibility of designing vehicles and machinery with a comprehensive modular approach, due to the ease of electric cable design layout. High performance EMAs are formed by a ball screw drive coupled to an electric motor; the result is a compact, rigid, high-force capable and extremely accurate position control actuator, with fewer vibration problems. Some manufacturers predict an efficiency increase of about 50% [112], and in the literature there are instances of transmission efficiency gains up to 83%, such as in [113], where the hydraulic lifting system of an electric forklift is replaced by an electromechanical actuator.

Table 4. Hydraulic system enhancement.

Strategy	Comment	Vehicle	References
Reducing idle losses			
Variable displacement pump	Main valve causes 60% of losses	Excavator	[26]
Variable displacement and variable speed pump	Efficiency gain up to 28.5%	Excavator	[106]
Decentralized drive	Independent drive of ancillaries	Excavator	[105]
Reducing hydraulic losses			
Individual Metering Control	Energy saving up to 44%	Excavator	[107]
Direct-driven hydraulics	Overall efficiency up to 73%	Excavator	[96,97]
Digital hydraulics	Fuel reduction up to 30%	Excavator	[108]
Multi-chamber actuators	Fuel efficiency gain up to 50%	Excavator	[110]
Replacement of the whole hydraulics			
Electro-mechanical actuators	Efficiency gain up to 83%	Forklift	[113]



## 7.2. Energy Recovery Systems

Energy recovery systems have been recognized as the main advantages of electrification since the adoption of the first hybridization systems in the automotive industry. Due to the fact that the off-highway industry is characterized by the absence of a one-size-fits-all solution, based on the type of vehicle and especially its mission, the strategies for recovering energy can be very different, as well as the type of technology. However, generally speaking, the two most common forms of recovery are the kinetic energy regeneration and the potential energy regeneration [114].

The most known strategy for recovering kinetic energy is regenerative braking, which is already a must-have for hybrid and electric cars; thanks to the use of efficient transmission systems, brake-by-wire systems and effective control strategies, it guarantees the recovery of a high amount of energy. The basic principle is to recover the kinetic energy of the wheels during deceleration instead of dissipating it by means of traditional friction brakes, which remain mandatory due to their high braking power. In off-highway vehicles, this strategy is very promising for vehicles that experience significant variations in speed, like front-end loaders, or machinery with high-energy braking demands during descent from hills; for instance, in [115], a 31% fuel reduction was achieved on a 20-ton hybrid front-end loader, while in [82], the regenerative braking model constituted an essential part of the model of a 15-kW electric municipal vehicle. These two vehicles had mechanical transmissions between the wheels and the motor/generator; accordingly, they adopt supercapacitors and batteries, respectively, to store the recovered energy, similarly to passenger vehicles. However, in the off-highway industry, there are many vehicles that drive the wheels by means of the hydraulic system, and consequently, while on the one hand this enhances the possibility of storing the energy in hydraulic accumulators, on the other hand, it adds a degree of complexity to the system. For instance, the Wirtgen Group (Tirschenreuth, Germany) has a diesel hybrid tandem roller capable of recovering the braking energy into hydraulic accumulators (Figure 15a); thanks to this architecture, the recovered energy can be used to achieve the same performance as that of the pure diesel version while reducing the ICE size from 85 kW to 55.6 kW [116]. In [117], a simulation of a battery-powered hydrostatic vehicle was presented, with an in-depth comparison between the storage of recovered energy in hydraulic accumulators, in a battery, and both; the results showed that the highest energy efficiency was obtained when the energy was totally stored into the battery pack, while pure hydraulic storage presented the worst efficiency gain. Even if the deceleration of the moving vehicles is the main source of kinetic energy, there are vehicles that usually work at fixed point, like excavators or material handlers; in such cases, the aim is to recover the kinetic energy from the swing of the upper structure. In [118], where a swing system with a hydraulic accumulator was designed and tested on a test bench, the results showed a regeneration efficiency of up to 70%. Another example is the 20-ton hybrid excavator by Hitachi Ltd. (Chidoya, Japan) [119,120] (Figure 15b); on this machine, the swing hydraulic motor is directly connected to an electric motor/generator, and the recovered energy is stored into a capacitor unit.

**Table 5.** Energy recovery systems.

Strategy	Comment	Energy accumulator	Vehicle	References
Potential energy				
Third boom actuator	Energy saving ratio up to 25.5%	Hydraulic accumulator	Excavator	[121]
Multi-chamber actuator	Reduction power consumption up to 50%	Hydraulic accumulator	Excavator	[122]
IMC	Energy saving up to 44%	Hydraulic accumulator	Excavator	[107]
Direct-driven hydraulics	Overall efficiency up to 73%	Battery	Excavator	[96,97]
Kinetic energy				
Regenerative braking	31% fuel reduction	Super capacitor	Wheel loader	[115]
Swing system	ICE downsizing from 85 kW to 55.6 kW	Hydraulic accumulator	Tandem roller	[116]
	Regenerative efficiency up to 70%	Battery, capacitor	Excavator	[118]

The second form of recoverable energy is the potential energy; its principle is the recovery of the gravitational potential energy of falling objects, like the boom of an excavator or of a front-end loader, and the load moved by a crane, a forklift or a reach stacker (Figure 15c). In [121], as shown in Table 5, an additional hydraulic cylinder and a hydraulic accumulator were added to a 76-ton mining excavator, achieving a tested energy-saving ratio of about 25%. In this regard, the use of novel hydraulic solutions can add the possibility of storing energy in hydraulic form, like the innovative three chamber cylinders presented in [122], where the simulation showed a reduction in power consumption of up to 50%; indeed, thanks to their complex geometry, it is possible to use the single actuator as a small hydraulic accumulator. A similar concept has been implemented in IMC systems, where a descending actuator can be identified as a hydraulic motor for other actuators, allowing the pump to stay idle for longer periods, and thus lowering the power consumption (Figure 16). The excellent fuel efficiency performance obtained with the compact excavator studied in [96,97] was achieved thanks to the enhanced possibility of electro-hydrostatic actuators driving their own pumps while lowering, thus generating electric power that can be stored in batteries or capacitors. Lastly, in [123], a combined recovery system (electric and hydraulic) was modeled in order to estimate the maximum amount of energy that can be recovered by exploiting the peculiar characteristics of both the energy storage systems, the energy density of batteries and the power density of hydraulic accumulators.



**Figure 15.** Off-highway vehicles with energy recovery systems. (a) Wirtgen-Group tandem roller. (b) Hitachi excavator. (c) Konecranes reach stacker. [116,124,125].



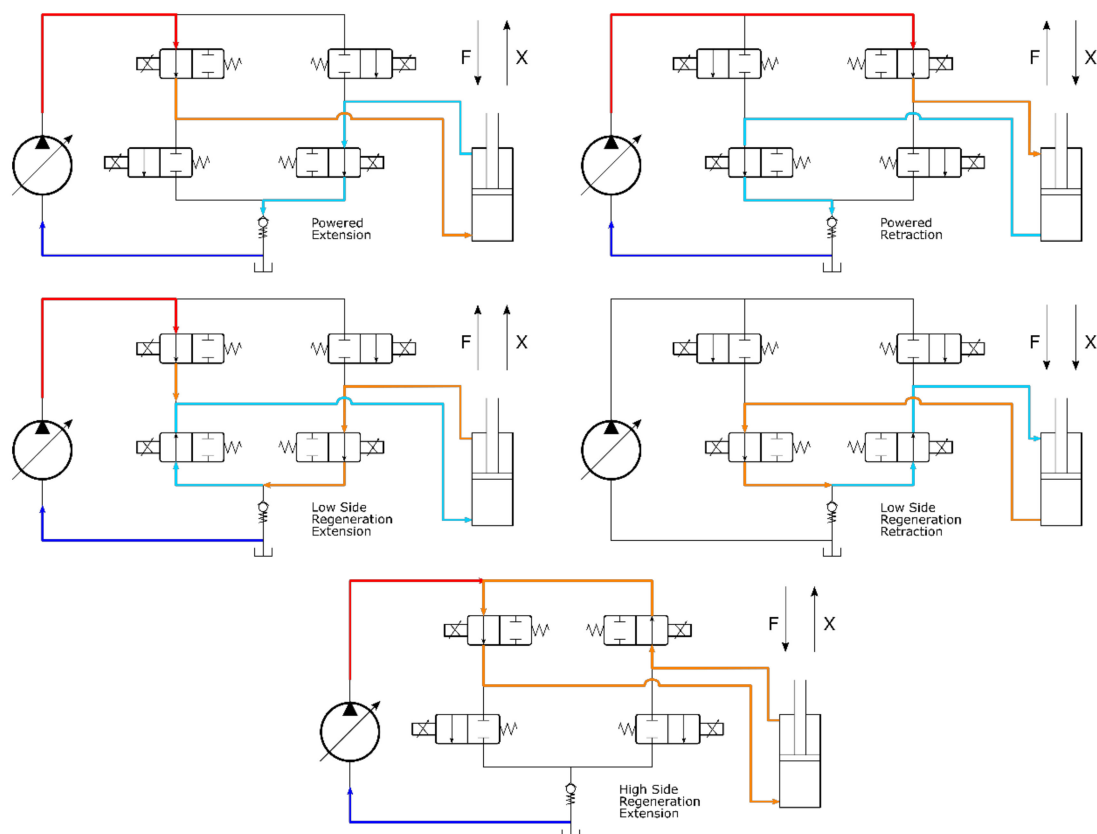

Figure 16. Scheme of an Individual Metering Control system (IMC) and working modes. (Adapted from [107]).

## 8. Hybrid Vehicles and Architectures

Like electric vehicles, hybrid architectures are considered to be among the most promising solutions for reducing energy consumption and local emissions, as well as improving performance in terms of controllability and productivity [126]; indeed, the focal point remains the optimization of the power flows in order to increase efficiency. The key difference with electric machinery is the presence of the ICE, which remains the main power source.

As mentioned in connection with duty cycles in Section 3, off-highway vehicles and machinery are characterized by highly fluctuating power flows, where the average power demand is much lower than the peaks. Consequently, hybridization can enable the downsizing of the ICEs, using the energy storage systems and the electric drives to respond to peak power demands.

The interaction between ICE, EMs, energy storage systems and loads (traction and/or hydraulic and/or implements) define three main hybrid architectures: series, parallel and series-parallel [127]; these are very similar to the automotive hybrid architectures, but with the essential difference that off-highway vehicles have to supply energy to both the traction system and the actuators and implements. In this regard, in contrast to the automotive industry, in [128], a novel definition of the hybridization factor was provided. In fact, while in the on-highway industry the hybridization factor considers only the tractive effort (propulsion hybridization factor), for off-highway vehicles and machinery is essential to consider the power demand of hydraulics and/or implements (loading hybridization factor).

Based on the weight and power classes of off-highway vehicles, the drivers for hybridization are slightly different. On the one hand, for medium size vehicles, which are regarded as the most interesting in the near future [129], the main drivers are reductions in the total cost of ownership and the enhancement of productivity; examples of machinery that follows these trends include the off-highway vehicles shown in Table 6, where, if stated

in the references, there are also reported their energy saving percentages in relation to the ICE versions. Even if some of these vehicles have been on the market for several years, their use has been limited thus far, mainly due to the much higher upfront costs; for instance, in the on-highway industry, the same thing happened with hybrid buses, which never really took off [5], even though they were able to achieve a fuel consumption reduction of up to 20% with respect to conventional buses [130].

**Table 6.** List of hybrid mid-size off-highway vehicles.

Manufacturer	Vehicle	Hybrid Architecture	Energy Accumulator	Energy Saving	References
Komatsu	20-ton excavator	Parallel hybrid	Super capacitor	25–41%	[131]
Hitachi	20-ton excavator	Parallel hybrid	Super capacitor	25%	[120]
Kobelco	20-ton excavator	Parallel hybrid	Lithium battery	16%	[132]
Hitachi	18-ton wheel loader	Series hybrid	Super capacitor	31%	[115]
Rigitrac	91 kW tractor	Series hybrid	\	Unknown	[133]
John Deere	140 kW tractor	Series hybrid	\	Unknown	[134]
Huddig	116 kW backhoe loader	Series hybrid	\	Unknown	[135]

On the other hand, regarding more compact machinery, manufacturers are analyzing the hybridization of vehicles just above 56 kW mainly with the aim of avoiding advanced exhaust gas treatment systems; indeed, above this power limit, the European Stage V emission regulation [8] mandates the presence of an exhaust gas treatment system, which is not only an expensive component, it also requires a large amount of space, which is already very limited on compact vehicles.

Examples of this trend include the various projects on the hybridization of compact agricultural tractors [18,19,136,137], where the main objectives are the possibility of downsizing the ICE and addition a pure electric mode, which could be useful for less demanding tasks or for use inside greenhouses. However, even if there are some cases of hybrid compact vehicles below 56 kW, like the hybrid skid loader studied in [20,21], their higher efficiency does not justify their higher upfront cost.

A different but fascinating approach to the hybridization of compact tractors has been shown by Landini (Fabbrico, Italy) with its REX4 Electra [138]: instead of reducing the ICE, the main aim of the project was the improvement of productivity. Indeed, the electric motors are only mounted on the front axle, and they allow for two essential benefits: the first is the four-wheel drive mode with accurate slip control, the second is the use of the torque vectoring to enhance steering capability.

Finally, it is worth mentioning that machinery equipped with hydrogen ICEs or fuel cells are considered hybrid vehicles. Indeed, in both cases, the hydrogen is consumed to satisfy the average power demand, while energy storage systems are used to achieve peak loads and to recover energy.

Examples of hydrogen hybrid off-highway projects are the forklifts studied in [87,88], the excavators studied in [22,139] and the reach stacker and terminal tractor used in the experimental project explained in [140].

## 9. Conclusions

This paper gathers together all the main topics surrounding the electrification of off-highway vehicles, with a clear focus on compact vehicles and the technologies that best fit such machinery.

After a first, necessary classification of the off-highway vehicles, the main differences regarding drive cycles and duty cycles were highlighted, evidencing, with respect to the latter, the absence of standard and globally recognized cycles, mainly due to their high complexity and the extreme variability of their operating conditions and tasks. The types of electric vehicle architectures were presented along with the most important technologies related to energy storage systems and motors/generators. It was shown that lithium batteries are currently recognized as being the state of the art for the storage systems,

while the choice of the electric motor is highly dependent on the application, even if much attention has recently been given to switched reluctance motors. Then, the state of the art of electric vehicles and machinery was described, focusing on the construction category, and some common trends were found that can also be extended to other types of off-highway vehicles. After the overview regarding some of the more interesting electric solutions among the different off-highway categories, the current and future technologies related to hydraulics, actuators and energy recovery systems were investigated.

The different topics and the current state of the art were analyzed, giving rise to the following comments:

- In the off-highway machinery industry, the reduction of emission is not the only major driver for electrification. Indeed, the decrease of fuel consumption, the enhancement of productivity and, more generally, the clear convenience in terms of total cost of ownership are key points to successfully breaking into the market. Nonetheless, the political and technical choices of the authorities with respect to the environment and sustainability will be essential, with the presence of economic incentives and/or taxes being important variables to consider.
- The technical concept of mission and duty cycles has always been fundamental aspect of the off-highway industry, and these factors will be even more important for bringing effective, efficient and economically sustainable machinery to the market. Indeed, there are already work environments where battery or tethered electric vehicles represent the best technical and economical compromise, such as underground mining or indoor logistics. The continuous developments and the constant reduction in costs contributes to the introduction of new electric vehicles, even in highly complex work environments, like construction and agriculture.
- There are technical limits to a more widespread electrification within the off-highway machinery industry, and these mainly depend on power demands and minimum operational runtime. Less energy-demanding duty cycles in urban or indoor environments or high profitable businesses like vineyards facilitate the use of electric vehicles, especially in case of the compact ones. Conversely, bigger machinery with more intense duty cycles in more harsh environments is less suitable for battery electrification in the near future, mainly because the operational runtime achievable with the current technology cannot guarantee the minimum number of working hours, and the charging infrastructures are usually very difficult to implement in such contexts.
- Among the common trends, the most evident is the retrofitting of existing vehicles, where the electric motors and the battery pack replace the ICE and the fuel tank, with the rest of the machinery remaining almost unchanged (hydraulics, actuators, overall design, etc.). This strategy allows manufacturers to put functional vehicles on the market in the nearest future, but there is usually some distance to go before they are fully optimized. Indeed, there is generally great room for improvement, especially with respect to hydraulics.
- The application of new technologies regarding hydraulics, actuators and energy recovery systems can greatly boost the efficiency of off-highway vehicles, both electric and ICE-powered ones. On the other hand, the introduction of innovative technologies can greatly increase the upfront costs, frequently exceeding the acceptable cost-benefit ratio, as has already occurred in case of hybrid excavators.

In conclusion, compact vehicles can be an excellent application for boosting the electrification process, mainly because they are usually more suited for zero-emission tasks, while development costs can be more easily minimized. It is certain that, in the immediate future, the demand for zero-emission compact vehicles will increase due to the increasing focus on environmental sustainability; however, in order to design extremely efficient and effective products, manufacturers and researchers still need to devote a great deal of effort towards research and development, especially regarding the implementation of novel, better-connected hydraulics and with respect to the in-depth study of the energy flows during duty cycles. Furthermore, a more widespread development of the electrification

of compact vehicles could be useful for speeding up the development of highly tailored solutions, promptly responding to customers' demands. Indeed, the application of many different types of electric implements and accessories will be easier and faster compared to actual hydraulic systems, with the final goal of achieving modular and highly alterable machinery, capable of completing many types of duty cycles based on their equipment. Eventually, the widespread electrification of compact vehicles would allow for a more comprehensive understanding of the available technologies, reducing their costs and allowing their use on bigger and more energy-demanding machinery, with resulting benefits both in terms of productivity and environmental sustainability.

**Author Contributions:** Investigation, D.B. and S.U.; writing—original draft preparation D.B. and S.U.; data curation D.B.; supervision, S.U.; writing—review and editing P.I. and L.T. All authors have read and agreed to the published version of the manuscript.

**Funding:** This research received no external funding.

**Institutional Review Board Statement:** Not applicable.

**Informed Consent Statement:** Not applicable.

**Data Availability Statement:** The data presented in this study are available on request from the corresponding author. The data are not publicly available due to University of Brescia privacy policy.

**Conflicts of Interest:** The authors declare no conflict of interest.

## Abbreviations

DC	Direct Current
EM	Electric Motor
EMA	Electro-Mechanical Actuator
ICE	Internal Combustion Engine
IM	Induction Motor
IMC	Individual Metering Control
NCA	Lithium Nickel Cobalt Aluminum Oxide
NEDC	New European Driving Cycle
NMC	Lithium Nickel Manganese Cobalt Oxide
OEM	Original Equipment Manufacturer
PMSM	Permanent Magnet Synchronous Motor
PTO	Power Take-Off
SOC	State of Charge
SRM	Switched Reluctance Motor
WLTP	World harmonized Light-duty vehicles Test Procedure

## References

1. The European Commission. *The European Green Deal*; The European Commission: Brussels, Belgium, 2019; Volume 1.
2. Zawieska, J.; Pieriegud, J. Smart City as a Tool for Sustainable Mobility and Transport Decarbonisation. *Transp. Policy* **2018**, *63*, 39–50. [[CrossRef](#)]
3. IEA Global EV Outlook 2019. Available online: <https://www.iea.org/reports/global-ev-outlook-2019> (accessed on 21 January 2021).
4. The European Commission. *Comunicazione Della Commissione Al Parlamento Europeo, Al Consiglio Europeo, Al Consiglio, Al Comitato Economico e Sociale Europeo, Al Comitato Della Regioni e Alla Banca Europea per Gli Investimenti*; European Commission: Brussels, Belgium, 2018.
5. Lajunen, A.; Sainio, P.; Laurila, L.; Pippuri-Mäkeläinen, J.; Tammi, K. Overview of Powertrain Electrification and Future Scenarios for Non-Road Mobile Machinery. *Energies* **2018**, *11*, 1184. [[CrossRef](#)]
6. Dallman, T.; Menon, A. *Technology Pathways for Diesel Engines Used in Non-Road Vehicles and Equipment*; International Council on Clean Transportation (ICCT): Washington, DC, USA, 2016.
7. United States Environmental Protection Agency. Regulations for Emissions from Heavy Equipment with Compression-Ignition (Diesel) Engines, Regulations for Emissions from Vehicles and Engines. Available online: <https://www.epa.gov/regulations-emissions-vehicles-and-engines/regulations-emissions-heavy-equipment-compression#e-cfr> (accessed on 21 January 2021).
8. Emission Standards. Europe: Nonroad Engines. Available online: <https://dieselnet.com/standards/eu/nonroad.php> (accessed on 21 January 2021).

9. Caban, J.; Vrabel, J.; Šarkan, B.; Zarajczyk, J.; Marczuk, A. Analysis of the Market of Electric Tractors in Agricultural Production. *MATEC Web Conf.* **2018**, *244*, 1–10. [CrossRef]
10. Monnay, C. *Potential and Trends in Off-Highway Vehicle Electrification*; Semcon: Gothenburg, Sweden, 2017.
11. Iora, P.G. *Tecnologie per La Mobilità Sostenibile: Veicoli Elettrici, Ibridi e a Fuel Cell*; Società Editrice Esculapio: Bologna, Italy, 2016; ISBN 978-88-7488-994-5.
12. Hegazy, O.; Barrero, R.; Van den Bossche, P.; El Baghdadi, M.; Smekens, J.; Van Mierlo, J.; Vriens, W.; Bogaerts, B. Modeling, Analysis and Feasibility Study of New Drivetrain Architectures for off-Highway Vehicles. *Energy* **2016**, *109*, 1056–1074. [CrossRef]
13. EPA. EPA Nonregulatory Nonroad Duty Cycles, MOVES and Other Mobile Source Emissions Models. Available online: <https://www.epa.gov/moves/epa-nonregulatory-nonroad-duty-cycles#individual> (accessed on 22 January 2021).
14. Meeting, A.; Report, K.N. *Experiences and Visions of an Implement Manufacturer*; Club of Bologna: Bologna, Italy, 2010.
15. Malavatu, J.; Kandke, S.R.; Gupta, S.; Agrawal, B. Design Challenges in Electrification of Off-Highway Applications. In Proceedings of the 2019 IEEE Transportation Electrification Conference (ITEC-India), Bengaluru, India, 17–19 December 2019. [CrossRef]
16. Mastrogiovanni, S. DLG-PowerMix. Available online: [https://www.enama.it/userfiles/PaginaSezione/files/S.\\_Mastrogiovanni\\_DLG.pdf](https://www.enama.it/userfiles/PaginaSezione/files/S._Mastrogiovanni_DLG.pdf) (accessed on 3 March 2021).
17. Brenna, M.; Foiadelli, F.; Leone, C.; Longo, M.; Zaninelli, D. Feasibility Proposal for Heavy Duty Farm Tractor. In Proceedings of the 2018 International Conference of Electrical and Electronic Technologies for Automotive, Milan, Italy, 9–11 July 2018. [CrossRef]
18. Dalboni, M.; Santarelli, P.; Patroncini, P.; Soldati, A.; Concarì, C.; Lusignani, D. Electrification of a Compact Agricultural Tractor: A Successful Case Study. In Proceedings of the 2019 IEEE Transportation Electrification Conference and Expo (ITEC), Detroit, MI, USA, 19–21 June 2019. [CrossRef]
19. Troncon, D.; Alberti, L.; Mattetti, M. A Feasibility Study for Agriculture Tractors Electrification: Duty Cycles Simulation and Consumption Comparison. In Proceedings of the 2019 IEEE Transportation Electrification Conference and Expo (ITEC), Novi, MI, USA, 1 June 2019; IEEE: New York, NY, USA, 2019; pp. 1–6.
20. Bertini, A.; Ceraolo, M.; Lutzemberger, G. Systematic Approach in the Hybridization of a Hydraulic Skid Loader. *Autom. Constr.* **2015**, *58*, 144–154. [CrossRef]
21. Bertini, A.; Ceraolo, M.; Lutzemberger, G. Development of a Hybrid Skid Loader through Modelling. In Proceedings of the 2012 IEEE International Energy Conference and Exhibition (ENERGYCON), Florence, Italy, 9–12 September 2012; pp. 1022–1027. [CrossRef]
22. Alan, C.; Ali, S.; Alaa, H.; Eric, B. Optimal Sizing of an Energy Storage System for a Hybrid Vehicle Applied to an Off-Road Application. In Proceedings of the 2014 IEEE/ASME International Conference on Advanced Intelligent Mechatronics, Besancon, France, 8–11 July 2014; IEEE: New York, NY, USA; pp. 775–780.
23. Nevrlý, J.; Fichta, M.; Jurik, M.; Nemeč, Z.; Koutný, D.; Vorel, P.; Procházka, P. Battery Electric Drive of Excavator Designed with Support of Computer Modeling and Simulation. *Proceedings* **2020**, *58*, 25. [CrossRef]
24. Schneider, S.; Vincenz, D. *SUNCAR Elektrobagger*. Available online: <https://www.aramis.admin.ch/Default?DocumentID=46789&Load=true> (accessed on 3 September 2021).
25. Vauhkonen, N.; Liljeström, J.; Maharjan, D.; Mahat, C.; Sainio, P.; Kiviluoma, P.; Kuosmanen, P. Electrification of Excavator. In Proceedings of the 9th International DAAAM Baltic Conference “INDUSTRIAL ENGINEERING”, Tallinn, Estonia, 24–26 April 2014; pp. 305–310.
26. Salomaa, V.; Minav, T.; Mattila, J.; Pietola, M. Efficiency Study of an Electro-Hydraulic Excavator. Master’s Thesis, Tampere University of Technology, Tampere, Finland, 2017.
27. Casoli, P.; Riccò, L.; Campanini, F.; Bedotti, A. Hydraulic Hybrid Excavator-Mathematical Model Validation and Energy Analysis. *Energies* **2016**, *9*, 1002. [CrossRef]
28. Construction Mechanization Association. *Earth-Moving Machinery—Test Methods for Energy Consumption—Hydraulic Excavators*; JCMAS: Tokyo, Japan, 2010.
29. Lin, T.; Lin, Y.; Ren, H.; Chen, H.; Chen, Q.; Li, Z. Development and Key Technologies of Pure Electric Construction Machinery. *Renew. Sustain. Energy Rev.* **2020**, *132*, 110080. [CrossRef]
30. Liebherr Liebherr Mining Goes Electric—Liebherr. Available online: <https://www.liebherr.com/en/ita/latest-news/news-press-releases/detail/liebherr-mining-goes-electric.html> (accessed on 5 March 2021).
31. Paraszczak, J.; Svedlund, E.; Fytas, K.; Laflamme, M. Electrification of Loaders and Trucks – A Step towards More Sustainable Underground Mining. *Renew. Energy Power Qual. J.* **2014**, *1*, 81–86. [CrossRef]
32. Połom, M. Trends in the Development of Trolleybus Transport in Poland at the End of the Second Decade of the 21st Century. *Pr. Kom. Geogr. Komun. PTG* **2018**, *21*, 44–59. [CrossRef]
33. Tribioli, L.; Chiappini, D.; Vukotić, M.; Miljavec, D. *Performance Evaluation of an Electric Vehicle with Multiple Electric Machines for Increased Overall Drive Train Efficiency*; SAE Technical Paper; SAE International: Warrendale, PA, USA, 2019. [CrossRef]
34. Sobotzik, J. *Electric Drives Potentials on Tractors and Implements*; John Deere: Moline, IL, USA, 2011.
35. Nishanth, F.N.U.; Khamitov, A.; Severson, E.L. Comparison of Linear and Rotary Electric Machine Topologies for a Hybrid Hydraulic Electric Architecture of Off-Highway Vehicles. In Proceeding of the 2020 IEEE Transportation Electrification Conference & Expo (ITEC), Chicago, IL, USA, 23–26 June 2020; pp. 1063–1068. [CrossRef]



36. Jo, D.Y.; Kwak, S.; Kim, N. Development of Fuel-Efficient Construction Equipment. In “Green World with Power Electronics”, *Proceedings of the 8th International Conference on Power Electronics—ECCE Asia, Jeju, Korea, 30 May–3 June 2011*; IEEE: New York, NY, USA, 2011; pp. 31–37.
37. Emadi, A. *Advanced Electric Drive Vehicles*, 1st ed.; CRC Press: Boca Raton, FL, USA, 2014.
38. Nykvist, B.; Nilsson, M. Rapidly Falling Costs of Battery Packs for Electric Vehicles. *Nat. Clim. Chang.* **2015**, *5*, 329–332. [[CrossRef](#)]
39. Ding, Y.; Cano, Z.P.; Yu, A.; Lu, J.; Zhongwei, C. Automotive Li-Ion Batteries: Current Status and Future Perspectives. *Electrochem. Energy Rev.* **2019**, *2*, 1–28. [[CrossRef](#)]
40. Yang, X.G.; Liu, T.; Wang, C.Y. Thermally Modulated Lithium Iron Phosphate Batteries for Mass-Market Electric Vehicles. *Nat. Energy* **2021**, *6*, 176–185. [[CrossRef](#)]
41. Wang, H.; Wang, Q.; Hu, B. A Review of Developments in Energy Storage Systems for Hybrid Excavators. *Autom. Constr.* **2017**, *80*, 1–10. [[CrossRef](#)]
42. Wang, J.; Yang, Z.; Liu, S.; Zhang, Q.; Han, Y. A Comprehensive Overview of Hybrid Construction Machinery. *Adv. Mech. Eng.* **2016**, *8*, 1–15. [[CrossRef](#)]
43. Hui, S.; Lifu, Y.; Junqing, J. Hydraulic/Electric Synergy System (HESS) Design for Heavy Hybrid Vehicles. *Energy* **2010**, *35*, 5328–5335. [[CrossRef](#)]
44. Casoli, D.-I.P.; Riccò, I.L.; Campanini, I.F.; Lettini, I.A.; Dolcin, I.C. Hydraulic Hybrid Excavator: Layout Definition, Experimental Activity, Mathematical Model Validation and Fuel Consumption Evaluation. In Proceedings of the 10th International Conference on Fluid Power (IFK), Dresden, Germany, 8–10 March 2016.
45. Lin, T.; Wang, L.; Huang, W.; Ren, H.; Fu, S.; Chen, Q. Performance Analysis of an Automatic Idle Speed Control System with a Hydraulic Accumulator for Pure Electric Construction Machinery. *Autom. Constr.* **2017**, *84*, 184–194. [[CrossRef](#)]
46. Rizzoni, G. *Fundamentals of Electrical Engineering by Giorgio Rizzoni*, 1st ed.; McGraw-Hill: New York, NY, USA, 2009; ISBN 978-0-07-338037-7.
47. Rajashekar, K. Present Status and Future Trends in Electric Vehicle Propulsion Technologies. *IEEE J. Emerg. Sel. Top. Power Electron.* **2013**, *1*, 3–10. [[CrossRef](#)]
48. Moreda, G.P.; Muñoz-García, M.A.; Barreiro, P. High Voltage Electrification of Tractor and Agricultural Machinery—A Review. *Energy Convers. Manag.* **2016**, *115*, 117–131. [[CrossRef](#)]
49. Mapelli, F.L. The Role of Motor Controllers in the Electrification Process. In Proceedings of the Industrial Vehicle Technology Virtual Expo, London, UK, 9–10 February 2021.
50. Un-Noor, F.; Padmanaban, S.; Mihet-Popa, L.; Nurunnabi Mollah, M.; Hossain, E.; Saponara, S. A Comprehensive Study of Key Electric Vehicle (EV) Components, Technologies, Challenges, Impacts, and Future Direction of Development. *Energies* **2017**, *10*, 1217. [[CrossRef](#)]
51. Yang, Z.; Shang, F.; Brown, I.P.; Krishnamurthy, M. Comparative Study of Interior Permanent Magnet, Induction, and Switched Reluctance Motor Drives for EV and HEV Applications. *IEEE Trans. Transp. Electrif.* **2015**, *1*, 245–254. [[CrossRef](#)]
52. Boldea, I.; Tutelea, L.N.; Parsa, L.; Dorrell, D. Automotive Electric Propulsion Systems with Reduced or No Permanent Magnets: An Overview. *IEEE Trans. Ind. Electron.* **2014**, *61*, 5696–5711. [[CrossRef](#)]
53. Riba, J.R.; López-Torres, C.; Romeral, L.; Garcia, A. Rare-Earth-Free Propulsion Motors for Electric Vehicles: A Technology Review. *Renew. Sustain. Energy Rev.* **2016**, *57*, 367–379. [[CrossRef](#)]
54. Grayson, W. Bobcat’s Electric Excavator Retrofit a First Step Toward an All-Electric Future, Equipment World. Available online: <https://www.equipmentworld.com/alternative-power/battery-electric/video/14972534/bobcats-electric-excavator-retrofit-a-first-step-toward-an-allelectric-future> (accessed on 11 March 2021).
55. *Clean Air Action Plan*; Municipality of Amsterdam: Amsterdam, The Netherlands, 2019; pp. 1–93.
56. Volvo. Volvo CE and Volvo Trucks Customer Deliveries of All-Electric Products. Available online: <https://www.volvoce.com/global/en/news-and-events/press-releases/2020/volvo-ce-and-volvo-trucks-customer-deliveries-of-all-electric-products/> (accessed on 12 March 2021).
57. Wordsworth, S. Wacker Neuson and the Emissions-Free Worksite. Available online: <https://www.ivtinternational.com/videos/video-wacker-neuson-and-the-emissions-free-worksite.html> (accessed on 12 March 2021).
58. Big Buyers Zero-Emission Construction Sites. Available online: <https://bigbuyers.eu/working-groups/past/zero-emission-construction-sites> (accessed on 21 April 2021).
59. ISO. ISO—ISO 6469-3:2018—Electrically Propelled Road Vehicles—Safety Specifications—Part 3: Electrical Safety. Available online: <https://www.iso.org/standard/68667.html> (accessed on 12 March 2021).
60. Bilo, J.; Burghoff, H.-G.; dos Santos, H.; Engbring, J. *48 Volt Electrical Systems—A Key Technology Paving the Road to Electric Mobility*; Zwei: Frankfurt, Germany, 2016.
61. Fischer, H.-M.; Dorn, L. *Voltage Classes for Electric Mobility*; ZWEI: Frankfurt, Germany, 2013.
62. Jenkins, J. High-Voltage EV Battery Packs: Benefits and Challenges. More Voltage, More Better?—Charged EVs. Available online: <https://chargedevs.com/features/high-voltage-ev-battery-packs-benefits-and-challenges-more-voltage-more-better/> (accessed on 12 March 2021).
63. *Global Off-Highway Vehicle Electrification Trends, Forecast to 2030*; Frost and Sullivan: Santa Clara, CA, USA, 2019.
64. JCB. JCB 525-60E, Electric Telehandler. Available online: <https://www.jcb.com/en-gb/products/telescopic-handlers/525-60e-hi-viz> (accessed on 16 April 2021).



65. Ueka, Y.; Yamashita, J.; Sato, K.; Doi, Y. Study on the Development of the Electric Tractor—Specifications and Traveling and Tilling Performance of a Prototype Electric Tractor. *Eng. Agric. Environ. Food* **2013**, *6*, 160–164. [CrossRef]
66. E-mining AG Products, E-Mining AG. Available online: <https://www.emining.ch/en/products> (accessed on 16 April 2021).
67. Friedrichshafen, Z.F. ZF ETRAC Driveline System for Electric Vehicles. Available online: <https://www.oemoffhighway.com/drivetrains/product/21126638/zf-friedrichshafen-ag-zf-etrac-driveline-system-for-electric-vehicles> (accessed on 11 March 2021).
68. *Electrification of Mobile Applications*; Boasch Rexroth AG: Lohr am Main, Germany, 2018.
69. *Market Positioning*; Deutz AG E-DEUTZ: Cologne, Germany, 2018.
70. Buning, E.A. Electric Drives in Agricultural Machinery—Approach from the Tractor Side. *J. Agric. Eng.* **2010**, *47*, 30.
71. CEMA. *European Agricultural Machinery Industry: CEMA Priorities and Key Figures*; CEMA: Brussels, Belgium, 2019; pp. 1–15.
72. Fendt. Fendt E100 Vario, Fendt FutureFarm—Fendt. Available online: <https://www.fendt.com/it/e100-vario> (accessed on 1 April 2021).
73. Rigitrac. Rigitrac SKE 40 Electric—Rigitracs Webseite! Available online: <https://www.rigitrac.ch/produkte-1/rigitrac-ske-40-electric/> (accessed on 1 April 2021).
74. Tractor, M. Monarch Tractor Electric Tractor. Available online: <https://www.monarchtractor.com/> (accessed on 1 April 2021).
75. Farmtrac Farmtrac—Trattori. Available online: <https://www.farmtracitalia.it/trattori> (accessed on 20 April 2021).
76. Van Leeuwen, L.B. Hydrogen or Battery Tractors: What Potential for Sustainable Grape Growing? *IVES Tech. Rev. Vine Wine* **2020**. [CrossRef]
77. Allen, J.; Deere, J. Develops Fully Electric, Autonomous Tractor, Industrial Vehicle Technology International. Available online: <https://www.ivtinternational.com/news/agriculture/john-deere-develops-fully-electric-autonomous-tractor.html> (accessed on 18 May 2021).
78. E-OX EOX—175. Available online: <https://www.e-ox.nl/eox-175> (accessed on 20 April 2021).
79. Pialorsi, R. Stato Dell’arte Dei Veicoli Elettrici e Studio Dell’eletrificazione Di Un Veicolo Industriale Con Trasmissione Meccanica. Master’s Thesis, Università degli Studi di Brescia, Brescia, Italy, 2019.
80. DULEVO Scopri La Nuova Spazzatrice Stradale Elettrica DZero2. Available online: <https://dzero2.dulevo.com/it/index.xhtml> (accessed on 2 April 2021).
81. Boschung Urban-Sweeper S2.0—Electric Street Sweeper Releasing 0 (Zero) Emissions. Available online: <https://www.boschung.com/product/urban-sweeper-s2-0/> (accessed on 2 April 2021).
82. Uberti, S.; Azzini, G.; Beltrami, D.; Tribioli, L.; Iora, P. *Modelling of a 15-KW Electric Utility Vehicle and Range Assessment through Driving Cycle Analysis Based on GPS Experimental Data*; SAE Technical Paper; SAE International: Warrendale, PA, USA, 2020. [CrossRef]
83. Esagono Energia Home—Esagono Energia, S.r.l.—Veicoli Elettrici. Available online: <https://www.esagonoenergia.com/> (accessed on 26 April 2021).
84. Morris, C. Charged EVs, Dennis Eagle’s New Electric Refuse Trucks Hit the Streets, Earn Rave Reviews—Charged EVs. Available online: <https://chargedevs.com/newswire/dennis-eagles-new-electric-refuse-trucks-hit-the-streets-earn-rave-reviews/> (accessed on 21 April 2021).
85. Sullivan, J. Gas Versus Electric Forklifts—Which Is Better? Available online: <https://www.tmhnc.com/blog/gas-versus-electric-forklifts-which-is-better> (accessed on 6 April 2021).
86. Fu, S.; Chen, H.; Ren, H.; Lin, T.; Miao, C.; Chen, Q. Potential Energy Recovery System for Electric Heavy Forklift Based on Double Hydraulic Motor-Generators. *Appl. Sci.* **2020**, *10*, 3996. [CrossRef]
87. Keränen, T.M.; Karimäki, H.; Viitakangas, J.; Vallet, J.; Ihonen, J.; Hyötylä, P.; Uusalo, H.; Tingelöf, T. Development of Integrated Fuel Cell Hybrid Power Source for Electric Forklift. *J. Power Sources* **2011**, *196*, 9058–9068. [CrossRef]
88. Hosseinzadeh, E.; Rokni, M.; Advani, S.G.; Prasad, A.K. Performance Simulation and Analysis of a Fuel Cell/Battery Hybrid Forklift Truck. *Int. J. Hydrogen Energy* **2013**, *38*, 4241–4249. [CrossRef]
89. Yale, H. CLS Cls-Hyster.It—CLS S.p.A.—CGT Logistica Sistemi. Available online: <https://cls-hyster.it/> (accessed on 26 April 2021).
90. Simai Simai—Europe’s Widest Range of Electric Tow Tractors and Platform Trucks. Available online: <https://www.simai.it/en/home-2/> (accessed on 26 April 2021).
91. Sennebogen. SENNEBOGEN 817 E: Compact Material Handler for the Waste Industry—SENNEBOGEN Maschinenfabrik GmbH. Available online: <https://www.sennebogen.com/en/news/news-press/sennebogen-817-e-compact-material-handler-for-the-waste-industry> (accessed on 26 April 2021).
92. Electric Motor Engineering Partnership for the Industrial Full Electric Loader—Electric Motor Engineering. Available online: <https://www.electricmotorengineering.com/partnership-for-the-industrial-full-electric-loader/> (accessed on 20 April 2021).
93. JCB 19C-1. JCB E-TECH, JCB.Com. Available online: <https://www.jcb.com/it-it/products/mini-escavatori/19c-1e> (accessed on 6 April 2021).
94. Tobroco Giant Electric Loaders from Tobroco—Giant Can Be Used All Year Long. Available online: <https://www.tobroco-giant.com/en/products/wheel-loaders/giant-g2200e-x-tra/> (accessed on 6 April 2021).
95. Volvo Prototype Electric Excavator. Available online: <https://www.volvoce.com/global/en/this-is-volvo-ce/what-we-believe-in/innovation/prototype-electric-excavator/> (accessed on 6 April 2021).
96. Zhang, S.; Minav, T.; Pietola, M. Decentralized Hydraulics for Micro Excavator. In Proceedings of the 15th Scandinavian International Conference on Fluid Power, SICFP’, Linköping, Sweden, 7–9 June 2017; pp. 17187–17195. [CrossRef]

97. Zhang, S.; Minav, T.; Pietola, M.; Kauranne, H.; Kajaste, J. The Effects of Control Methods on Energy Efficiency and Position Tracking of an Electro-Hydraulic Excavator Equipped with Zonal Hydraulics. *Autom. Constr.* **2019**, *100*, 129–144. [CrossRef]
98. Arnulfo, S. JCB Dà Il Benvenuto Al 1° Escavatore 100% Elettrico: JCB 19C-1 E-TEC. Available online: <http://www.veicolidalavoro.it/jcb-escavatore-100-elettrico-jcb-19c-1-tec/> (accessed on 26 April 2021).
99. Tobroco Giant G2200E Series, Giant Loaders. Available online: <https://giantloaders.com/products/g2200e-series/> (accessed on 26 April 2021).
100. Volvo Construction Equipment. Volvo CE Unveils 100 Percent Electric Compact Excavator Prototype: Volvo Construction Equipment. Available online: <https://www.volvoce.com/global/en/news-and-events/press-releases/2017/volvo-ce-unveils-100-percent-electric-compact-excavator-prototype/> (accessed on 26 April 2021).
101. Volvo. Volvo CE Unveils the next Generation of Its Electric Load Carrier Concept: Volvo Construction Equipment. Available online: <https://www.volvoce.com/global/en/news-and-events/press-releases/2017/conexpo-vegas-2017/volvo-ce-unveils-the-next-generation-of-its-electric-load-carrier-concept/> (accessed on 21 April 2021).
102. Vukovic, M.; Leifeld, R.; Murrenhoff, H. Reducing Fuel Consumption in Hydraulic Excavators—A Comprehensive Analysis. *Energies* **2017**, *10*, 687. [CrossRef]
103. Minav, T.A.; Heikkinen, J.E.; Pietola, M. Direct Driven Hydraulic Drive for New Powertrain Topologies for Non-Road Mobile Machinery. *Electr. Power Syst. Res.* **2017**, *152*, 390–400. [CrossRef]
104. An, K.; Kang, H.; An, Y.; Park, J.; Lee, J. Methodology of Excavator System Energy Flow-Down. *Energies* **2020**, *13*, 951. [CrossRef]
105. Jensen, S. A Shifting Fluid Power Industry, OEM Off-Highway. Available online: <https://www.oemoffhighway.com/fluid-power/article/21244542/a-shifting-fluid-power-industry> (accessed on 17 February 2021).
106. Ge, L.; Quan, L.; Zhang, X.; Zhao, B.; Yang, J. Efficiency Improvement and Evaluation of Electric Hydraulic Excavator with Speed and Displacement Variable Pump. *Energy Convers. Manag.* **2017**, *150*, 62–71. [CrossRef]
107. Choi, K.; Seo, J.; Nam, Y.; Kim, K.U. Energy-Saving in Excavators with Application of Independent Metering Valve. *J. Mech. Sci. Technol.* **2015**, *29*, 387–395. [CrossRef]
108. Pellegri, M.; Green, M.; Macpherson, J.; McKay, C.; Caldwell, N. Applying a Multi-Service Digital Displacement® Pump to an Excavator to Reduce Valve Losses. In *Fluid Power Future Technology, Proceedings of the 12th International Fluid Power Conference, Dresden, Germany, 12–14 October 2020*; Technische Universität Dresden: Dresden, Germany, 2020; pp. 59–68. [CrossRef]
109. The European Commission. NorrDigi Revolutionary Energy Saver, Norrdigi Project, H2020, CORDIS, European Commission. Available online: <https://cordis.europa.eu/project/id/830085/it> (accessed on 25 March 2021).
110. Gehm, R. Volvo CE and Norrhydro Digital Hydraulics. Available online: <https://www.sae.org/news/2020/12/volvo-ce-and-norrhydro-digital-hydraulics> (accessed on 25 March 2021).
111. Qiao, G.; Liu, G.; Shi, Z.; Wang, Y.; Ma, S.; Lim, T.C. A Review of Electromechanical Actuators for More/All Electric Aircraft Systems. *J. Mech. Eng. Sci.* **2018**, *232*, 4128–4151. [CrossRef]
112. Lotz, T. Best Practices for Electrification of Mobile Machines. Available online: <https://www.oemoffhighway.com/trends/electrification/article/21342313/best-practices-for-electrification-of-mobile-machines> (accessed on 1 April 2021).
113. Wang, L.; Zhao, D.; Li, Y.; Du, M.; Chen, H. Energy Management Strategy Development of a Forklift with Electric Lifting Device. *Energy* **2017**, *128*, 435–446. [CrossRef]
114. He, X.; Xiao, G.; Hu, B.; Tan, L.; Tang, H.; He, S.; He, Z. The Applications of Energy Regeneration and Conversion Technologies Based on Hydraulic Transmission Systems: A Review. *Energy Convers. Manag.* **2020**, *205*, 112413. [CrossRef]
115. Ishida, K.; Higurashi, M. Hybrid Wheel Loaders Incorporating Power Electronics. *Hitachi Rev.* **2015**, *64*, 398–402.
116. Wirtgen Group. HD + 90i PH VO, Rulli Tandem, HAMM. Available online: <https://www.wirtgen-group.com/ocs/it-it/hamm/hd-90i-ph-vo-1878-p/> (accessed on 18 April 2021).
117. He, X.; Liu, H.; He, S.; Hu, B.; Xiao, G. Research on the Energy Efficiency of Energy Regeneration Systems for a Battery-Powered Hydrostatic Vehicle. *Energy* **2019**, *178*, 400–418. [CrossRef]
118. Yu, Y.-X.; Ahn, K.K. *Energy Saving and Control of a Hybrid Hydraulic Excavator Swing System*; IEEE: New York, NY, USA, 2020. [CrossRef]
119. Hitachi Construction Machinery ZH210-5 Hybrid—Hitachi Construction Machinery. Available online: <https://www.hitachim.eu/it/prodotti/escavatori/escavatori-medi/zh210-5-hybrid/> (accessed on 18 April 2021).
120. Edamura, M.; Ishida, S.; Imura, S.; Izumi, S. Adoption of Electrification and Hybrid Drive for More Energy-Efficient Construction Machinery. *Hitachi Rev.* **2013**, *62*, 118–122.
121. Ge, L.; Dong, Z.; Quan, L.; Li, Y. Potential Energy Regeneration Method and Its Engineering Applications in Large-Scale Excavators. *Energy Convers. Manag.* **2019**, *195*, 1309–1318. [CrossRef]
122. Zhao, P.-Y.; Chen, Y.-L.; Zhou, H. Simulation Analysis of Potential Energy Recovery System of Hydraulic Hybrid Excavator. *Int. J. Precis. Eng. Manuf.* **2017**, *18*, 1575–1589. [CrossRef]
123. Lin, T.; Wang, Q.; Hu, B.; Gong, W. Research on the Energy Regeneration Systems for Hybrid Hydraulic Excavators. *Autom. Constr.* **2010**, *19*, 1016–1026. [CrossRef]
124. MMT Italia Hitachi ZH 210-5 Hybrid. Available online: [https://www.mmtitalia.it/macchine\\_edili/marchi/hitachi/modelli/escavatori\\_cingolati/hitachi\\_zh\\_210-5\\_hybrid](https://www.mmtitalia.it/macchine_edili/marchi/hitachi/modelli/escavatori_cingolati/hitachi_zh_210-5_hybrid) (accessed on 26 April 2021).
125. Konecranes Reach Stackers, Konecranes. Available online: <https://www.konecranes.com/equipment/lift-trucks/reach-stackers> (accessed on 26 April 2021).

126. Lajunen, A.; Suomela, J.; Pippuri, J.; Tammi, K.; Lehmuspelto, T.; Sainio, P. Electric and Hybrid Electric Non-Road Mobile Machinery—Present Situation and Future Trends. *World Electr. Veh. J.* **2016**, *8*, 172–183. [[CrossRef](#)]
127. He, X.; Jiang, Y. Review of Hybrid Electric Systems for Construction Machinery. *Autom. Constr.* **2018**, *92*, 286–296. [[CrossRef](#)]
128. Soma, A.; Bruzzese, F.; Mocera, F.; Viglietti, E. Hybridization Factor and Performance of Hybrid Electric Telehandler Vehicle. *IEEE Trans. Ind. Appl.* **2016**, *52*, 5130–5138. [[CrossRef](#)]
129. Truong, D.Q.; Marco, J.; Greenwood, D.; Harper, L.; Corrochano, D.G.; Yoon, J.I. Challenges of Micro/Mild Hybridisation for Construction Machinery and Applicability in UK. *Renew. Sustain. Energy Rev.* **2018**, *91*, 301–320. [[CrossRef](#)]
130. Huria, T.; Lutzemberger, G.; Sanna, G.; Pede, G. Systematic Development of Series-Hybrid Bus through Modelling. In Proceedings of the 2010 IEEE Vehicle Power and Propulsion Conference, Lille, France, 1–3 September 2010. [[CrossRef](#)]
131. Inoue, H. Introduction of PC200-8 Hybrid Hydraulic Excavators. *Komatsu Tech. Rep.* **2008**, *54*, 1–6.
132. Kobelco Europe. HYBRID—Kobelco Construction Machinery Europe B.V. Available online: <https://www.kobelco-europe.com/innovation/hybrid/> (accessed on 8 April 2021).
133. TU Dresden Rigitrac EWD 120. Available online: [https://tu-dresden.de/ing/maschinenwesen/int/ast/ressourcen/dateien/forschung/files/flyer\\_rigitrac.pdf?lang=en](https://tu-dresden.de/ing/maschinenwesen/int/ast/ressourcen/dateien/forschung/files/flyer_rigitrac.pdf?lang=en) (accessed on 8 April 2021).
134. Stoss, K.J.; Sobotzik, J.; Shi, B.; Kreis, E.R. Tractor Power for Implement Operation—Mechanical, Hydraulic, and Electrical: An Overview. *Agric. Equip. Technol. Conf.* **2013**, 1–25.
135. Huddig Tigon Huddig World’s Best Backhoe Loaders Made in Sweden. Available online: <https://www.huddig.com/products/machines/tigon/> (accessed on 8 April 2021).
136. Troncon, D.; Alberti, L.; Bolognani, S.; Bettella, F.; Gatto, A. Electrification of Agricultural Machinery: A Feasibility Evaluation. In Proceedings of the 2019 Fourteenth International Conference on Ecological Vehicles and Renewable Energies (EVER), Monte Carlo, Monaco, 8–10 May 2019; IEEE: New York, NY, USA; pp. 1–7.
137. Troncon, D.; Alberti, L. Case of Study of the Electrification of a Tractor: Electric Motor Performance Requirements and Design. *Energies* **2020**, *13*, 2197. [[CrossRef](#)]
138. Landini Landini REX4 Electra—Evolving Hybrid—Landini. Available online: <https://www.landini.it/en/landini-rex4-electra-evolving-hybrid/> (accessed on 20 April 2021).
139. Li, T.; Huang, L.; Liu, H. Energy Management and Economic Analysis for a Fuel Cell Supercapacitor Excavator. *Energy* **2019**, *172*, 840–851. [[CrossRef](#)]
140. H2ports First Application of Hydrogen Technologies in Port Handling Equipment in Europe. Available online: <https://h2ports.eu/wp-content/uploads/2020/03/H2PORTS-Brochure.pdf> (accessed on 26 August 2021).