



Calhoun: The NPS Institutional Archive
DSpace Repository

Others Look at NPS

Articles and Reports about NPS (External)

2012-04

SE Capstone Project: Building Systems Engineering Education and Workforce Capacity

Systems Engineering Research Center, Stevens Institute of Technology

<http://hdl.handle.net/10945/70119>

This publication is a work of the U.S. Government as defined in Title 17, United States Code, Section 101. Copyright protection is not available for this work in the United States.

Downloaded from NPS Archive: Calhoun



Calhoun is the Naval Postgraduate School's public access digital repository for research materials and institutional publications created by the NPS community. Calhoun is named for Professor of Mathematics Guy K. Calhoun, NPS's first appointed -- and published -- scholarly author.

Dudley Knox Library / Naval Postgraduate School
411 Dyer Road / 1 University Circle
Monterey, California USA 93943

<http://www.nps.edu/library>

SE Capstone Project

Building Systems Engineering Education and Workforce Capacity

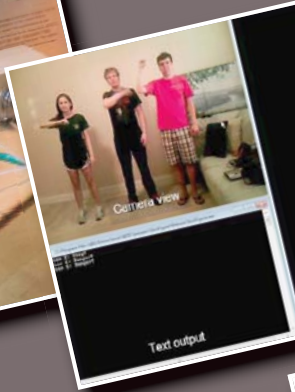
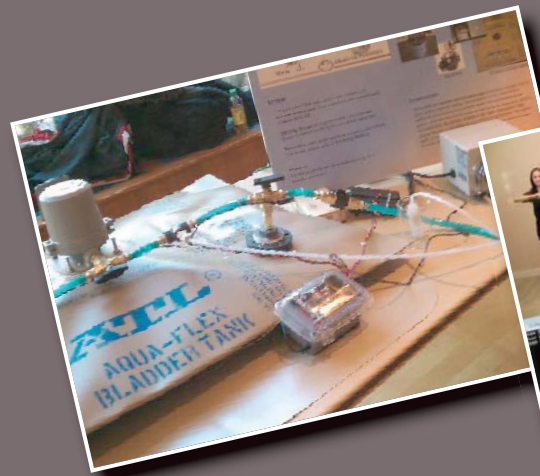
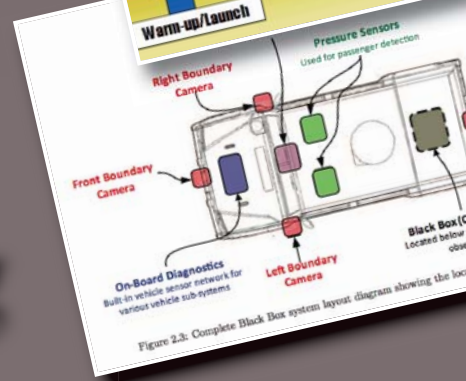

APRIL 2012

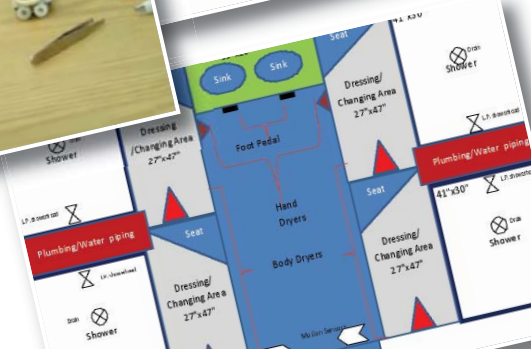

Report Documentation Page

Form Approved
OMB No. 0704-0188

Public reporting burden for the collection of information is estimated to average 1 hour per response, including the time for reviewing instructions, searching existing data sources, gathering and maintaining the data needed, and completing and reviewing the collection of information. Send comments regarding this burden estimate or any other aspect of this collection of information, including suggestions for reducing this burden, to Washington Headquarters Services, Directorate for Information Operations and Reports, 1215 Jefferson Davis Highway, Suite 1204, Arlington VA 22202-4302. Respondents should be aware that notwithstanding any other provision of law, no person shall be subject to a penalty for failing to comply with a collection of information if it does not display a currently valid OMB control number.

1. REPORT DATE APR 2012		2. REPORT TYPE		3. DATES COVERED 00-00-2012 to 00-00-2012	
4. TITLE AND SUBTITLE SE Capstone Project: Building Systems Engineering Education and Workforce Capacity				5a. CONTRACT NUMBER	
				5b. GRANT NUMBER	
				5c. PROGRAM ELEMENT NUMBER	
6. AUTHOR(S)				5d. PROJECT NUMBER	
				5e. TASK NUMBER	
				5f. WORK UNIT NUMBER	
7. PERFORMING ORGANIZATION NAME(S) AND ADDRESS(ES) Stevens Institute of Technology, Systems Engineering Research Center, Castle Point on the Hudson, Hoboken, NJ, 07030				8. PERFORMING ORGANIZATION REPORT NUMBER	
9. SPONSORING/MONITORING AGENCY NAME(S) AND ADDRESS(ES)				10. SPONSOR/MONITOR'S ACRONYM(S)	
				11. SPONSOR/MONITOR'S REPORT NUMBER(S)	
12. DISTRIBUTION/AVAILABILITY STATEMENT Approved for public release; distribution unlimited					
13. SUPPLEMENTARY NOTES					
14. ABSTRACT					
15. SUBJECT TERMS					
16. SECURITY CLASSIFICATION OF:			17. LIMITATION OF ABSTRACT	18. NUMBER OF PAGES	19a. NAME OF RESPONSIBLE PERSON
a. REPORT unclassified	b. ABSTRACT unclassified	c. THIS PAGE unclassified			

Table of Contents

INTRODUCTION.....	1
EXECUTIVE SUMMARY	2
PROJECT OVERVIEW	5
PROMISING PRACTICES	10
IMPACT ON STUDENTS.....	11
PARTICIPATING INSTITUTIONS.....	14
Air Force Institute of Technology.....	15
Auburn University	16
Missouri University of Science and Technology.....	17
Naval Postgraduate School.....	18
Pennsylvania State University Great Valley.....	19
Southern Methodist University.....	20
Stevens Institute of Technology	21
United States Air Force Academy.....	22
United States Coast Guard Academy.....	23
United States Military Academy.....	24
United States Naval Academy.....	25
University of Maryland	26
University of Virginia	27
Wayne State University	28
ACKNOWLEDGEMENTS.....	29



SYSTEMS ENGINEERING Research Center

The Systems Engineering Research Center (SERC) is a University Affiliated Research Center (UARC), competitively awarded by the U.S. Department of Defense to Stevens Institute of Technology in 2008. The SERC leverages the research and expertise of senior lead researchers from over 20 collaborator universities and not-for-profit research organizations throughout the United States, with 300 researchers working on nearly 30 research activities over the past 3 years. SERC researchers have worked with a wide variety of domains and industries and bring views and ideas from beyond the traditional defense industrial base. The SERC is sponsored by the Assistant Secretary of Defense for Research and Engineering, ASD(R&E), and includes strategic sponsors such as the Defense Acquisition University, the U.S. Army, and the U.S. Air Force. Through its collaborative research concept, the SERC embodies the potential to radically improve the application of systems engineering to the successful development, integration, testing and sustainability of complex systems, services and enterprises.

The SERC Vision:

The networked national resource to further systems research and its impact on issues of national and global significance.



This publication is based on research conducted by the SERC on Systems Engineering capstone courses. More details are available in the complete final report on this research, available at www.SERCuarc.org.

Introduction

Our world is overflowing with technology that constantly advances in complexity and interconnections. Global Positioning System (GPS), financial markets, mobile internet, air traffic control, social networking, credit/debit cards, and anti-lock brakes are only a few functions enabled by complex systems of systems. We depend on these systems with little or no conscious concern about their correct behavior. More important, the problems we face on a global scale will require the understanding of systems and solutions that are possibly more complex than we have ever imagined. Systems engineering is a multi-disciplinary practice that uses a holistic, systems approach to make sense of and manage the complexity of problems and solutions. Systems Engineering ensures that systems under development meet the needs of the stakeholders and that associated risks do not outweigh their benefits.

Building Systems Engineering Education and Workforce Capacity, a research study sponsored by the Systems Engineering Research Center (SERC), a University Affiliated Research Center of the United States Department of Defense (DoD), explores responses to a set of current realities within the U.S. education pipeline and labor pool:

- There is evidence that the U.S. is lagging in science, technology, engineering, and mathematics (STEM) education and training. (See, for example, a recent article by Andrew Rotherham in *Time* magazine published May 26, 2011: The Next Great Resource Shortage: U.S. Scientists)
- An article about the 50 best jobs in America by Rosato, Braverman, and Jeffries in the November 2009 *Money* magazine reports an expected 45% increase in systems engineering (SE) jobs in the next decade.

The original research was conceptualized and designed to pilot and evaluate approaches to effectively ameliorate these shortages through the development and delivery of university-level capstone courses. The study focused on increasing positive student experiences with SE through course design, mentor support, real-world project topics, and the use of multi-disciplinary teams. This publication acknowledges the original research and presents key lessons and implications that can be used for SE capstone courses and future research.

“Yes, systems engineering is a very diverse field with what seems like a fast pace and constant change. In addition, it seems like a job that would be challenging both on an intellectual level as well as a practical level. All of these reasons make systems engineering seem like a good career choice to me.”

– Student



Executive Summary

Building Systems Engineering Education and Workforce Capacity assessed the impact of a collection of Systems Engineering (SE) Capstone courses designed to:

1. Engage students in the learning and practice of SE through exposure to authentic Department of Defense (DoD) problems.
2. Explore educational approaches for addressing future DoD and related industry workforce needs in order to inform future investments for the purpose of institutionalizing and scaling up the methods found most effective.

Student outcomes showed improvements in SE and DoD problem awareness and an increase in student interest in and appreciation of the field. Site visits to participating institutions suggested nine promising practices for effective deployment of SE Capstone courses. These practices are now being investigated further in a follow-on study.

Fourteen schools, including six military educational institutions, participated. Follow-on research, in the form of a *Pilot for Scaling Up and Sustaining Effective SE Capstone Practices*, is currently underway, and applies the findings of this project to more schools in order to study best practices for expansion.



Research Goals

- Determine how different course designs, structures, materials, instructional practices, and other inputs—such as the involvement of DoD and industry mentors—impact student acquisition of SE knowledge and career interest in SE.
- Inform the development of a national scale-up effort to substantially expand the number of universities producing graduates with the level of systems thinking needed for the DoD and related defense industry workforce.
- Inform the sponsor about making future investments in SE Capstone courses for this national scale-up effort, e.g., what methods and approaches lead to greater student learning gains and greater SE career interest, particularly interest in DoD problems and careers.

The study also addressed two outcome-oriented questions:

- Do SE Capstone courses increase student awareness of DoD problems?
- To what degree do SE Capstone courses increase student interest in SE careers?

Participants

- More than 360 students were affected by this study.
- Featured 14 educational institutions, 8 civilian and 6 military.
- Approximately 30 DoD and industry mentors took part.
- Approximately 50 faculty participated.

Capstone Topic Areas

Student team projects at participating institutions were required to address at least one of four topic areas illustrating authentic DoD problems (for more detail, see Table 2):

1. Low-cost, low-power computers
2. Expeditionary assistance kits
3. Expeditionary housing systems
4. Immersive training technologies

Participating institutions selected their topic area(s) based on the expertise of participating faculty, institutional resources, and the availability of DoD and local experts, among other considerations.

Fourteen universities collaborated to develop systems engineering capstone courses.

Of the more than 360 students enrolled in the courses, approximately half were undergraduates (fourth-year seniors) and of graduates most were first-years.



Process

Participating institutions each developed an SE Capstone course, which in most cases took the form of an integrative, culminating, project-based course involving teams of students working together on the development of a product or prototype that addressed a real DoD need, such as ecologically-friendly expeditionary housing. Through these courses, participating university faculty developed, piloted, and assessed the efficacy of new course materials, methods, approaches, and strategies to recruit and provide substantive SE learning experiences and to increase student exposure to authentic DoD problems.

Role of Faculty

At the majority of institutions, participating faculty came from at least three separate engineering disciplines, literally embodying the multi-disciplinary nature of a real-world SE team.

Assessment Methods

- Pre/post student surveys measured changes in the level of student SE knowledge, awareness of DoD problem areas, and interest in SE careers.
- Pre/post case study analysis by students measured changes in the level of complexity of student thinking using SE knowledge on a case study analysis of the Bradley Fighting Vehicle.
- Student blog posts provided evidence of cumulative SE knowledge acquisition.
- Customized assessments were used by faculty to assess student outcomes.
- Additional data sources were: principal investigator (PI) reports; sponsor site visit teams; a culminating workshop; papers, posters, and presentations by faculty and students; and performance assessment data in the form of student prototypes and accomplishments in a variety of student competitions.

“I would love being a systems engineer working on complex projects especially in the DoD arena. As an SE I can see the whole picture of the project from the beginning to the end of its life cycle in addition to understanding the system's features inside out.”

– Student

Summary of Key Lessons

The following observations are distilled from the final report on this research, available at www.SERCuarc.org.

Do SE Capstone courses increase student awareness of DoD problems?

- Yes. Researchers observed students identifying more specific types of DoD problems, and increasing their use of SE terminology.

Is the use of industry, DoD, academic, and faculty mentors effective in increasing capstone course learning and student engagement?

- Mentors who participated in design reviews and had regular communication with student teams added significant value to student experiences. Effective use of mentors can be challenging and is being studied in the follow-on project.

To what degree do SE Capstone courses increase student interest in SE careers?

- A majority of both undergraduates and graduate students stated that they might choose careers in SE sometime in the future.
- The entire population demonstrated an increased awareness of general SE careers, SE careers in government, and SE careers in industry.

To what degree were students engaged in the learning and practice of SE?

- 82% of responding students felt their group produced a successful product.
- Post-course, participating students had a good understanding of general SE terminology.
- Analysis of the Bradley Fighting Vehicle case study showed an increase in student ability to identify problems that mapped to specific SE competencies.
- Blogs demonstrated students working through the phases of the SE design process.
- Students enjoyed the real-world nature of the projects and appreciated the SE perspective on their work.
- Overall, a large majority of respondents agreed that SE provided a useful framework and the broad perspective needed to manage complex engineering challenges.

Impacts of This Effort on DoD Workforce Issues

Implementing SE Capstone courses can have an impact on the workforce development issues facing the DoD and defense industry in a variety of ways.

LESSON	IMPLICATION
Implementing effective SE curricula increases student awareness and appreciation of SE research and employment	Increased awareness of SE careers in the student population
SE Capstone courses yield increases in student knowledge and understanding of SE	Graduates entering the workforce with increased SE core competency
Inclusion of mentors can have a positive impact on student experience	Better student outcomes in SE
Nine promising practices for SE capstone courses	Ready guidelines for effective SE curriculum design, development, improvement, and implementation



Investing in the Future

Pilot for Scaling Up and Sustaining Effective SE Capstone Practices, the follow-on research task to this project, studies the effective implementation of SE Capstone courses across a larger number of participating institutions performing a wider variety of roles. A similar number of participating students, faculty, and mentors in six new schools, six returning SERC schools, and four military institutions are taking part in this research. Several of the new schools this year do not currently have systems engineering courses or faculty, providing an important test of the scalability of these methods in a national program. The new schools include some historically black institutions and women's colleges, important areas of recruitment for a broader systems engineering workforce. *Pilot for Scaling Up and Sustaining Effective SE Capstone Practices* investigates expanding the roles of participating institutions into those of sub-team, separate service, and observer/adviser.

The SE Capstone model remains, though several of the student teams are geographically distributed across different schools, providing a more realistic and more challenging working environment. In addition, participating institutions are implementing the promising practices identified here, with the expectation that doing so will improve student outcomes across the

population. The follow-on study will further the discoveries of this project, provide a larger context for understanding the critical elements of the most effective SE educational model, and offer insight into promising practices for both institutionalizing these recommendations and scaling up adoption of SE Capstone courses.



Project Overview

A high rate of growth is expected in SE jobs in the next decade. The July 2010 National Defense Industrial Association (NDIA) white paper on critical SE challenges reported that: “The quantity and quality of SE expertise is insufficient to meet the demands of the government and defense industry.” The paper further outlined certain recommendations to build SE expertise and capacity, particularly highlighting the development of SE expertise through “role definition, selection, training, career incentives, and broadening ‘systems thinking’ into other disciplines.” Further recommendations included: adding an introductory course in SE to all undergraduate engineering and technical management degree programs, and working with major universities to recommend SE curricula to improve consistency across programs in order to achieve standardization of skill sets for graduates. With these industry-wide workforce demands challenging the systems engineering community, *Building Systems Engineering Education and Workforce Capacity* was conceptualized and designed to pilot and evaluate approaches to ameliorating these shortages.

Research Goals

Building Systems Engineering Education and Workforce Capacity, (referred to as the SE Capstone Project, or SE Capstone), aims to understand the methods through which SE learning and career interest may be increased among undergraduate and graduate engineering students. The key research question this program was designed to address is:

What organization of course work (course sequence, course materials, faculty characteristics, student characteristics and other inputs and activities) leads to the largest student gains in (1) SE learning; (2) interest in SE careers; and (3) interest in DoD problems and careers?

Study Process

This research was conducted in the context of "capstone" courses at 14 different schools, in most cases as project-based courses involving teams of students working together on the development of a product or prototype that addresses a real DoD need. Eight civilian universities and six military schools piloted methods, materials, and approaches in courses that embedded and augmented SE knowledge. The Systems Planning, Research Development, and Engineering (SPRDE)-SE and Program Systems Engineering (PSE)

competency model (Table 1) was used as a guideline in defining expected student outcomes. Participating university faculty developed new course materials and other methods and strategies to provide substantive SE learning experiences and increase exposure to authentic DoD problems, such as low-cost, low-power computing devices, expeditionary assistance kits, expeditionary housing systems, and immersive training technologies.

This pilot program was conducted as a first step toward the development of a national scale-up effort to expand the capabilities of universities to produce SE graduates needed for the DoD and related defense industry workforce. It was anticipated that a portfolio of shareable course materials, assessment instruments, and other lessons would be produced in order to accelerate the adoption of effective practices and materials in a national scale up. Analysis of student data from several sources, principal investigator reports, input from sponsors’ site visit teams, and insights gleaned from panels and presentations at a culminating workshop form the basis for the content of the final report and recommendations.

Analytical (13)	<ol style="list-style-type: none"> 1. Technical Basis for Cost 2. Modeling and Simulation 3. Safety Assurance 4. Stakeholder Requirements Definition (Requirements Development) 5. Requirements Analysis (Logical Analysis) 6. Architectural Design (Design Solution) 7. Implementation 8. Integration 9. Verification 10. Validation 11. Transition 12. System Assurance 13. Reliability, Availability, and Maintainability
Technical Management (12)	<ol style="list-style-type: none"> 14. Decision Analysis 15. Technical Planning 16. Technical Assessment 17. Configuration Management 18. Requirements Management 19. Risk Management 20. Technical Data Management 21. Interface Management 22. Software Engineering 23. Acquisition 24. Systems Engineering Leadership 25. System of Systems
Professional (4)	<ol style="list-style-type: none"> 26. Communications 27. Problem Solving 28. Strategic Thinking 29. Professional Ethics

Table 1: SPRDE-SE/PSE Competency Model

Student project teams were required to complete a project in one of the DoD Problem Areas and to produce a prototype product or artifact.

DoD Problem Areas

1. Low-cost, low-power computers leveraging open-source technologies and advanced security to support sustainable, secure collaboration; Portable, renewable power generation, storage, and distribution to support sustained operations in austere environments and reduce dependency on carbon-based energy sources; Portable, low-power water purification;
2. An expeditionary assistance kit based on low-cost, efficient, and sustainable prototypes such as solar cookers, small and transportable shelters, deployable information and communication technologies, water purifiers, and renewable energies. These materials would be packaged in mission-specific HA/DR kits for partner nation use;
3. Develop modular, scalable, expeditionary housing systems that possess "green" electric power and water generation, waste and wastewater disposal, hygiene, and food service capabilities. Systems should be designed to blend in to natural/native surroundings and with minimal footprint;
4. Continued investigation and exploration into the realm of the possible with respect to "Immersive" training technologies. Objective is to flood the training audience environment with the same stimuli that one would experience during actual mission execution. Where possible full sensory overload is desired much the same as experienced in combat. Specific simulation and training areas for development

Virtual Human. Successful modeling of emotions, speech patterns, cultural behaviors, dialogue and gestures.

Universal Language Model. The ability for trainees to seamlessly converse with the Virtual Human.

Virtual Character Grab Controls. The ability for exercise controllers to assume control of virtual characters.

Automated Programming. Cognitive learning models and the ability for exercise controllers to adjust virtual/live simulations.

Low Cost Wireless Personnel Sensors. Facilitates interaction between subjects.

Sensors (e.g., lightweight vests). Facilitate physical stimuli.

Table 2: DoD Problem Areas

“(I would pursue a career in SE because) the projects are always varying, and it's a more philosophical approach to engineering. Maintaining the technical details will be important, but having the flexibility to think about alternative designs based on systems engineering principles is more enticing.”

– Student

Research Methods

Methodology: Measurement of Student Educational Outcomes

The researchers measured impact of the variety of SE Capstone courses on the student outcomes through the administration of three assessments required of all SE Capstone student participants. These common assessments were administered at the beginning (pre-) and end (post-) of their Capstone course experience. These included:

1. Pre/Post Survey, focused on student knowledge of systems engineering, interest in systems engineering careers, and awareness of DoD problem areas.
2. Pre/Post Case Study Analysis [Bradley Fighting Vehicle], a semantic analysis designed to capture growth in SE approach/analysis.
3. Student Blogs were intended to provide qualitative evidence of the progress in level of sophistication of student analysis.

Also, faculty of each participating institution developed customized assessments unique to their courses that used diverse instruments such as:

- Comprehensive Rubrics
- Student Presentations/Briefings for design reviews and Final Project Presentation
- Peer Review
- Team Reports



Participating Institutions and Selection Criteria

A request for proposals was issued and a competitive application process was conducted in order to select SE Capstone partner institutions (Table 3). An independent panel of SE and engineering education experts used a common scoring rubric to evaluate 11 proposals, which resulted in the selection of 8 civilian institutions. A separate process managed by the Office of the Assistant Secretary of Defense for Research and Engineering [ASD(R&E)] resulted in the participation of 4 service academies working under the direction of the Naval Postgraduate School and Air Force Institute of Technology, bringing the total number to 14 partner institutions.

Civilian Universities	Military Institutions
1- Auburn University	1- Air Force Institute of Technology
2- Missouri University of Science and Technology	2- Naval Postgraduate School
3- Pennsylvania State University Great Valley	3- United States Air Force Academy
4- Southern Methodist University	4- United States Coast Guard Academy
5- Stevens Institute of Technology	5- United States Military Academy
6- University of Maryland	6- United States Naval Academy
7- University of Virginia	
8- Wayne State University	

Table 3: Partner Institutions

Timeline

The study ran for 20 months, from March 1, 2010 to October 31, 2011, and followed the timeline below:

Phase 1/Startup (March 1, 2010–May 15, 2010): Provided program requirements and executed subcontracts to enable partner universities to develop materials and conduct program implementation in the Fall 2010 academic semester. Two universities conducted one-semester SE Capstone courses; 11 conducted two-semester courses; and one organized its SE Capstone course over multiple terms.

Phase 2/Pilot Implementation (May 15, 2010–June 30, 2011): Partner institutions developed course materials and assessment instruments (July-September 2010); delivered the courses (August 2010-May 2011); and submitted two interim reports (July 2010 and January 2011) and a final

report (June 2011). Some variation in this schedule was based on the specific calendar for classes at each partner institution.

Phase 3/Analysis, Recommendations & Dissemination (July 1, 2011–October 31, 2011): This phase coordinated a summative workshop for the

“Projects are becoming more and more complex and today’s engineering feats combine so many different disciplines...[it’s] so important to understand systems engineering and be able to operate with different disciplines to form one cohesive project.”

– Student

constituents involved in this study and the follow-on study, and conducted an analysis of results of student assessments and other data and artifacts for submission in a final report.

Figure 1 shows the milestones of each phase:

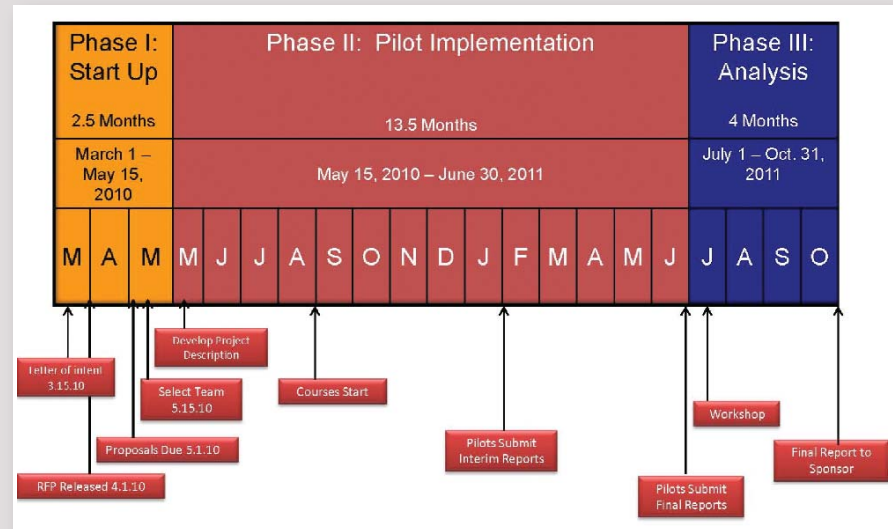

Figure 1: RT19 Project Timeline

Summary of Student Participants

According to final reports submitted by principal investigators, 330 and 257 students participated in study-sponsored SE Capstone courses in the fall 2010 and spring 2011 semesters, respectively. Many institutions enrolled the same students for both semesters, but a few enrolled a new cohort of students in the spring, bringing the total number of students who were affected to more than 360. Approximately half were undergraduates, of whom the majority were fourth-year seniors. Of the graduate students, most were first-year students, with a small percentage of post-graduates participating in roles such as project manager.

While the total number of undergraduates and graduate students was nearly equal across the institutions, a closer look at differences between individual institutions shows that nearly half of the SE Capstone classes were composed entirely of undergraduates. Four institutions enrolled graduate students (including postgraduate students) into the SE Capstones and the remaining three enrolled both undergraduate and graduate students.

Faculty Involvement

According to original proposals and project reports, approximately 50 faculty participated in the development, delivery, and assessment of the SE Capstone courses across the 14 participating institutions. A majority of the universities relied on the expertise of systems engineering faculty to lead or contribute to the conceptualization, development, and implementation of the program, but faculty from other disciplines—particularly mechanical engineering and computer science—were involved as well. At 11 institutions, faculty came from at least three separate engineering disciplines,

All Institutions - Student Participants

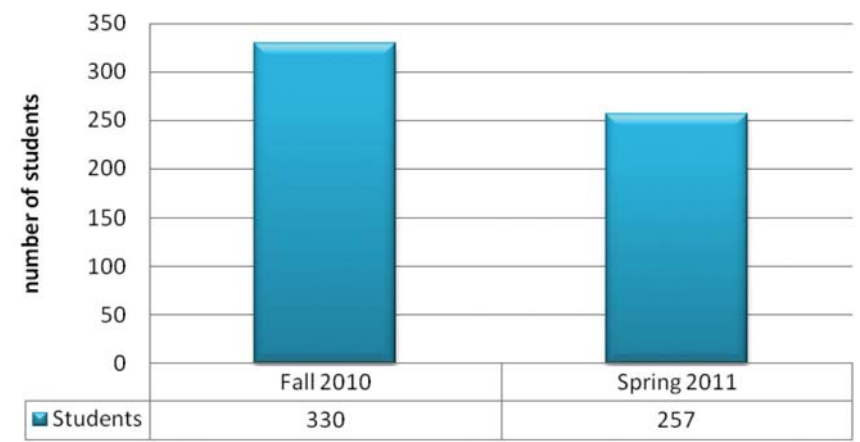

Figure 2: All Institutions – Student Participants

literally embodying the multi-disciplinary character of an authentic systems engineering team. In Figure 3, percentages represent the percentage of the 14 partner institutions that included those types of disciplinary faculty in this project.

Nearly two-thirds of the SE Capstone courses were planned and implemented by teams of two or three faculty members, and four projects included four or more faculty. Only one institution developed a capstone course that was planned and taught by a single faculty member.

Faculty Teams

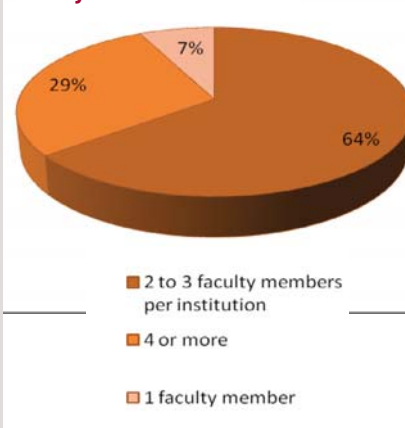

Figure 4: Faculty Teams

Faculty Involvement

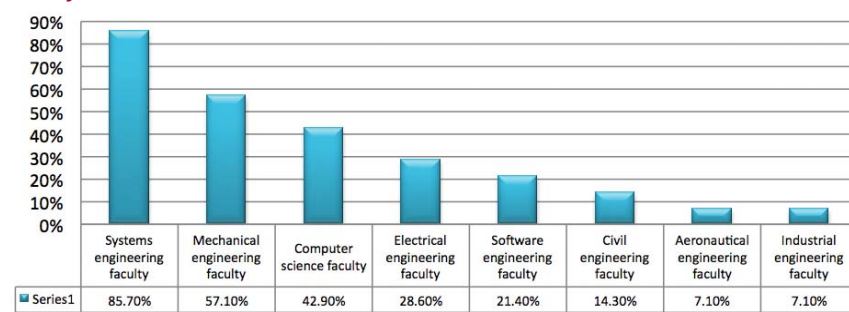

Figure 3: Faculty Involvement

DoD/Industry Mentors

Approximately 30 DoD and industry mentors contributed to the SE Capstone projects. In many cases, mentors were recruited from the project kickoff meeting in August 2010, while ASD(R&E) staff recruited the majority of remaining mentors after the meeting. In some institutions, mentors played multiple roles, such as client and as technical advisor.

Mentors included representatives from industry (such as Boeing, Lockheed Martin, SRI/Sarnoff, Red Gate Group, Ltd., and Northrup Grumman) as well as DoD (Office of Naval Research, U.S. Marine Corps, Naval Surface Warfare Center, Army TARDEC, and retired personnel).



“We came together and made sure that our sub-systems worked cohesively. We didn't just make separate sub-systems in the hopes that they would sync up and work together. We created an entire functioning systems engineering solution that is a huge success.”

– Student

Promising Practices

During spring 2011, ASD(R&E) representatives conducted site visits to all but one of the partner institutions. During these visits they identified a set of nine promising practices that were present in the courses in which students demonstrated the types of professional SE knowledge and skills that align with DoD's explicit or implicit workforce needs.

The representatives presented these practices during the 2011 summative workshop. The follow-on study, *Pilot for Scaling Up and Sustaining Effective SE Capstone Practices*, is now investigating the effectiveness of these practices in scaling up the deployment of SE Capstone courses.



1. Two-semester course sequence.

A fall semester tools, techniques, and approaches SE theory course, followed by a spring semester design project course. The fall course should present a balance of "traditional" SE approaches with automated tools, models, and simulation techniques.

2. Cross-disciplinary faculty and multi-disciplinary student teams.

These provide the best experience for students. Expectations of SE competencies (depth of knowledge/skill development) should be different for undergraduates and graduates. From the student perspective, the "real life experience" (e.g., communication, working with people from different backgrounds) is critical.

3. Regular, direct involvement of mentors with student project teams.

Mentor participation in design reviews is especially recommended. Regular contact, at least via teleconference, is needed to ensure that misunderstandings are quickly caught and corrected. Mentor involvement helps with the engineering process and works to foster SE career awareness and an appreciation for the SE field.

4. Established relationships with nearby DoD commands and facilities.

Leveraging these relationships improves student awareness of DoD problems and opportunities.

5. Creative use of mentors from defense industry contractors and DoD.

Some institutions had built-in relationships, either through past PI industry or military experience, or had connections to other military institutions. Use of such mentors provides an additional, solutions-oriented perspective.

6. Structured design reviews with DoD and industry mentors serving as reviewers.

Iterative reviews supplement faculty expertise and give students the opportunity to learn from their mistakes.

7. Use of SE Ph.D. candidates and advanced graduate students as project advisors.

Project advisors provide peer-level guidance for, and an alternative communication channel with, student teams.

8. Creative imposition of technical, budget, and schedule constraints by faculty to model "real world."

In addition, physical prototypes are considered important for student motivation, in order to demonstrate products for DoD sponsors, and in order to begin to pipeline projects to more advanced testing. Prototypes illustrate the tradeoffs made during the design process. Both software and hardware prototypes are acceptable, including decision-making software.

9. Where possible, established relationships with ROTC units.

ROTC units can provide assistance in requirements analysis, use case testing, and solution viability testing.

Impact on Students

Although the students only received an introduction to systems engineering, they nevertheless greatly appreciated the contribution that a systems engineering perspective made to their projects. In post-course surveys many students reported that this perspective had a positive impact on their projects. They often wrote about how it helped them systematically work through the entire design and creation cycle:



- “Yes, many of the concepts helped in the original planning of the project. It allowed us to systematically go about the design and implementation of our system. While I’m sure we would’ve worked everything out without it, systems engineering provided that general framework for designing our system.”
- “Yes. I think our learning benefited us when we were defining our requirements, developing our conceptual design, and by giving us a procedural and logical way to make decisions.”
- “Yes - the most intangible positive effect that I found was an almost continuous attention to the system-level view and the execution of the systems engineering process.”
- “Absolutely, when we started we first had to define the problem through stakeholder analysis, we then created alternatives, came up with a scoring method, scored each system, compared them for tradeoffs, and gave a recommendation. We followed the Systems Decision Making Process in order to solve the problem.”

There were four main reasons students considered their projects a success, with some students listing more than one reason. Fulfilling customer and system requirements was the most frequently cited reason, closely followed by producing a functional prototype. The other two reasons were: finding solutions to a real-life problem, and using SE concepts/processes.

Here are some sample responses:

- “The most successful part of the project was the learning experience. In every other engineering class I have taken, we have explicitly focused on the development of a single component or small system.” (Used SE concepts/processes)
- “Our ultimate objective was to lower the amount of fuel and water used within the bases. We achieved that goal by designing various systems which work together to lower those numbers significantly.” (Solved real life problems; fulfilled requirements)
- “The most successful aspect of the project was the excellent group dynamic and time management of the team.” (Used SE concepts/processes)
- “While the product is only a proof of concept, we were able to show that the basic design elements of the product would indeed work in the field. Many of the design elements were results of the client’s feedback and with consideration of the Soldier in mind.” (Fulfilled requirements)
- “[Our product] was manufactured by a Coast Guard Unit and was received very positively with our interaction with many different Coast Guard assets.” (Fulfilled customer requirements; solved real life problems)

Reasons for Success

Students cited four reasons for their success:

1. Fulfilled customer and system requirements.
2. Produced a functional prototype.
3. Found solutions to a real-life problem.
4. Used SE concepts/processes.

- “We all worked together and designed a product that we were able to test, demonstrate, and present to many different companies and symposiums effectively.” (Produced a functional prototype)
- “Our group offers a design that will decrease convoys to Forward Operating Bases by 50%.” (Solved real life problems)

80 percent of post-course survey student respondents reported that they would be interested in choosing a career in systems engineering, often after they had spent some time in their own engineering track.

It was notable that money was almost never listed as a reason for choosing SE as a career. The largest number was drawn to systems engineering because they liked being able to see the larger picture of the systems they helped create:

- *“I would choose a career in system engineering because for every project that I am involved with, I like to have an overall understanding of the system. A career in engineering is not just finishing my assignments and making money for the family, it is about delivering a wonderful product that meets customer needs within budget and meets the schedule.”*

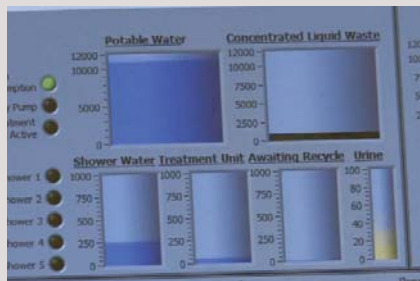

They also liked the variety of projects that engage systems engineers:

- *“In the future I may decide to pursue a career in systems engineering because you're exposed to a wide variety of areas, not just one specific area. The projects in systems engineering vary much more than in individual engineering fields.”*

And finally, they liked the challenges posed by working on a large system, the ability to see the process through from beginning to end, and the interdisciplinary and problem-solving aspects of systems engineering:

- *“Yes (I would pursue a career in SE) because I love working on huge projects and managing a whole lot of people... it's so rewarding in the end to see the final huge project. I learned a lot and I really am considering a career in systems engineering because I had a blast working with all of the people in my group.”*
- *“Yes, systems engineering allows an individual to be a part of many stages in a solutions process. This fact allows for a robust and challenging experience, which appeals to me.”*
- *“Yes, as a systems engineer it's your job to make sure all of the pieces fit together in a project, which is a challenge in itself and one of the things that separates good products from bad product.”*
- *“Yes, it is interesting to be able to break a project down and analyze it based on different factors in order to prove it is a viable and cost effective project.”*
- *“Yes, I enjoy the detailed nature of the process as well as the satisfaction of a good complete design.”*
- *“Due to the fact that systems engineering is an interdisciplinary field and requires a thorough understanding of a number of working principles, I would choose a career in it.”*
- *“Yes. I feel like as an engineer I have struggled to find my niche as I like so many different facets of Mechanical Engineering and engineering in general. SE allows me to learn many different fields and develop a specialization as I develop as a systems engineer.”*

Almost all of the students cited one or more reasons why systems engineering would be applicable and useful to their future career plans and studies, including:

- Practically applying systems engineering concepts such as requirements analysis, lifecycle models, problem definition, and project/risk management to design.
- Working in interdisciplinary teams on complex, real-life problems with tangible customers and outcomes.
- Experiencing firsthand the communication needs and demands of their teams and clients.



Sample responses include:

- *“Yes, regardless [of] what I do in the future, systems engineering has given me a broad perspective on the application of various fields.”*
- *“Yes because projects are becoming more and more complex and today's engineering feats combine so many different disciplines. Therefore it is so important to understand systems engineering and be able to operate with different disciplines to form one cohesive project.”*
- *“Yes, the methods of tracking requirements and specifications will be extremely applicable in the engineering world as design teams become more global. The need to share information and document clearly when and where a decision oriented and why is extremely important in a multinational design system.”*
- *“Yes, they teach very well how teams of people from different backgrounds should communicate and work together. In the real job world almost all teams consist of people from different academic backgrounds so it is very useful.”*
- *“Systems engineering will be applicable to my future plans. I will be joining the military and knowing how the various systems I come into contact with work together is important.”*
- *“Future work will require design and integration of new and legacy systems. In order to accomplish these efforts, an understanding of interfaces, project requirements, system functions, and their interdependencies will be needed to field a system given the anticipated constraints of budget and schedule. The SE approaches and models help focus these efforts.”*
- *“The approaches and models allow you to systematically outline requirements of the customer and then craft out steps to be followed to achieve these requirements. Where changes are made to any of the design requirement, the models would be modified accordingly to align with the customer. Everything about systems engineering is essentially about the customer.”*
- *“[Systems engineering approaches and models] help me to see the big picture of the projects that I am involved in. Proper management of the project saves time and money because it clearly defines the end result, the testing and verification process.”*
- *“I have found the greatest success when working with people with different backgrounds and using a systems engineering approach. This approach includes the management of the project throughout its entire life cycle.”*

Participating Institutions:

Fourteen educational institutions participated, eight civilian and six military

Air Force Institute of Technology



Auburn University



Missouri University of Science and Technology



Naval Postgraduate School



Pennsylvania State University Great Valley



Southern Methodist University



Stevens Institute of Technology



United States Air Force Academy



United States Coast Guard Academy



United States Military Academy



United States Naval Academy



University of Maryland



University of Virginia



Wayne State University



Air Force Institute of Technology

Faculty: David Jacques

Prototypes:

This project involved the design, construction and testing of an Unmanned Air Vehicle with a novel hybrid-electric propulsion system. One of the goals of the project was to demonstrate long-loiter, near silent operations with reduced energy needs. The hybrid-electric propulsion system was designed, built and tested by AFIT students. The airframe, while built by a small business contractor, was fabricated per student specifications in terms of weight, volumetric and aerodynamic performance parameters.

The Hybrid Electric Unmanned Aerial Vehicle (HEV) architecture provides a blueprint for vehicle development, gap analysis, and testing. It also serves as a reference for future HEV development and verification and production of a system intended to provide an enabling concept for covert operations for coalition unmanned air systems. The architecture highlights key operational parameters valued by the war-fighter and serves as a guide in validating performance requirements.

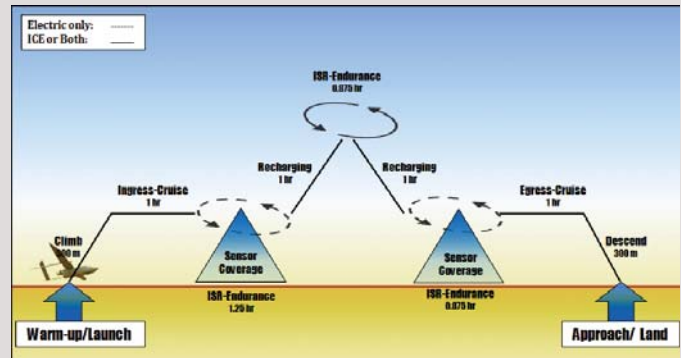

Auburn University

Faculty: David Umphress, Drew Hamilton, Alice Smith

Prototypes: Four teams developed four different prototypes:

Project 1: Augmented Reality Using Android Mobile Phones

This project developed an application for mobile phones that tags geographical points of interest and communicates those tags securely to others within a squad. The phone's onboard camera displays a real-time field of view overlaid with markers for friendly and hostile forces.

Project 2: Augmented Reality via iPod

This project developed an inexpensive networking device that plugs into the standard headphone jack of a mobile phone or MP3 player. It tags geographical points of interest and communicates securely with others in a squad using interoperable open source hardware.

Project 3: Drone Surveillance via Android

This project combined an off-the-shelf robotic vacuum cleaner outfitted with an Xbox Kinect sensor and remote-control radio. The system broadcasts a camera image from drones controlled with Android mobile phones and tablets. The drones follow map coordinates selected from an Android phone and transmit images back to the phone.

Project 4: Platoon Communication via Android

This project used Android devices to allow platoon members to communicate troop movement instructions among themselves, and to communicate air-strike and medevac requests to a headquarters base. Endorsement and validation from active duty Marines played a key role in designing and validating the system.

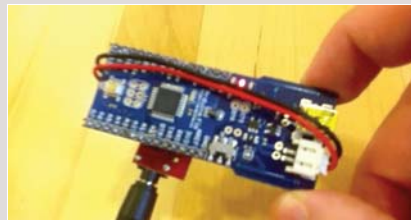

Missouri University of Science and Technology

Faculty: C.H. Dagli, Steven Corns, Ivan Guardiola

Prototypes:

This project developed a lightweight vest with embedded sensors and wireless links to provide environment data and allow excitation of aural or physical feedback signals. The final product provides two main capabilities:

- (1) Haptic feedback system for battlefield training scenarios
- (2) A feedback system that allows soldier interaction with a civilian. For this scenario a second vest was developed so that the soldier can receive positive and negative feedback regarding their interaction with a civilian.

The vest systems are connected through a wireless ad-hoc communication network. Different sets of communication sequences were developed to provide “correct” and “incorrect” responses to civilian interactions.

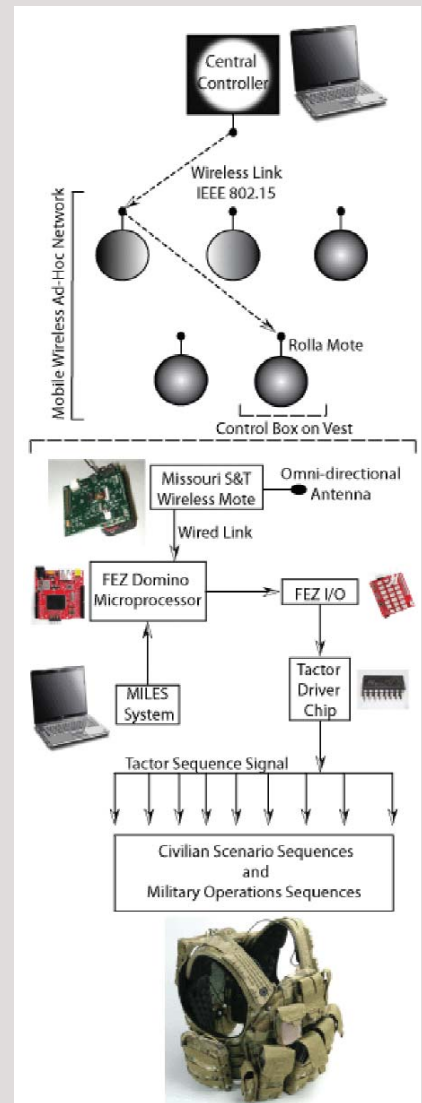

Naval Postgraduate School

Faculty: Clifford Alan Whitcomb, Diana I. Angelis, Gary Oliver Langford, Gregory Alan Miller, Ali Rodgers, Mark Richard Stevens

Prototypes:

This project developed an expeditionary system that includes the situational awareness and pertinent forecasts necessary to support decision makers in preparing for and delivering humanitarian aid during times of crisis. The system provides short-term and long-term survival to those affected, while also meeting the organizational, communication and basic human needs of those providing aid.



NPS Students Improve PACOM's Response

- Readiness to make decisions in first few hours (<3 hrs) to plan to respond to disasters Now: 3 days
- Presence on the ground with appropriate response in first few days (<3 days) Now: 5-7 days
- Partnership with host countries, NGOs, locals

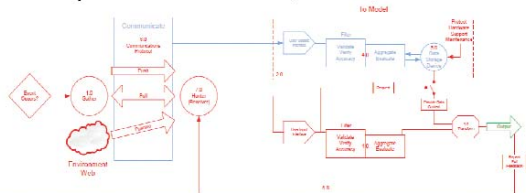

"PACOM is very enthusiastic to work with NPS RT -19 Project for HA/DR"
Dave Brown, J2; Dr. Biff Baker, Jim Ehlert, PACOM 11 Feb 2011

Pennsylvania State University Great Valley

Faculty: James A. Nemes, Sven Bilén, Elizabeth Kisenwether, Robert Capuro, Mary Lynn Brannon

Prototypes:

This project was divided into four teams that contributed separate elements to an expeditionary housing kit.

Team 1 provided automated water purification and storage.

Team 2 was responsible for power generation, including protection mechanisms for backup power.

Team 3 provided local situation awareness capability.

Team 4 was responsible for communications, including local and global satellite capability.

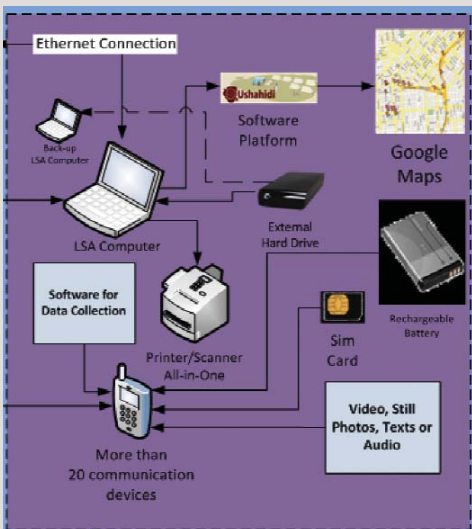
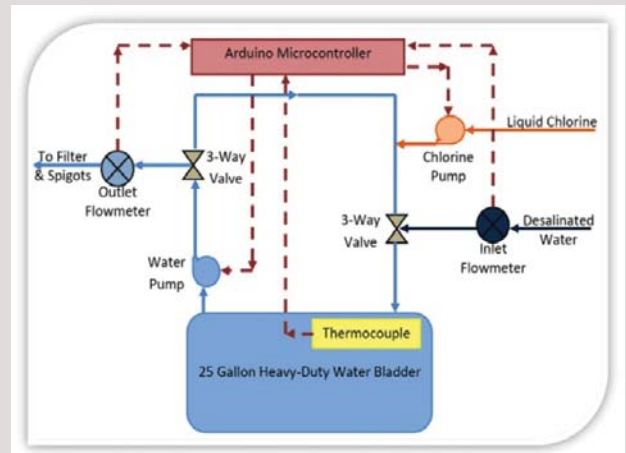

Southern Methodist University

Faculty: LiGuo Huang, Nathan R. Huntoon

Prototypes:

Project 1: Multiple User Motion Capture

This project developed a system for capturing and mapping hand gestures from Marine trainees to their corresponding avatars in a virtual training environment. The final product builds upon the Microsoft Kinect motion tracking hardware and supporting drivers. Body tracking data from the Kinect are analyzed with a series of tests based on communication gestures featured in Virtual Battlespace 2 software. Once a gesture is recognized by a test it is communicated to the virtual training environment.

Project 2: Micro Expression Facial Motion Capture

This project developed a system to capture an actor's face in real time and transfer it onto a 3-D avatar. Using one scientific camera and a process called structured light, the user's image is captured to create a depth map of the face. An edge detection algorithm is then applied and the image is rendered and displayed to the soldier.

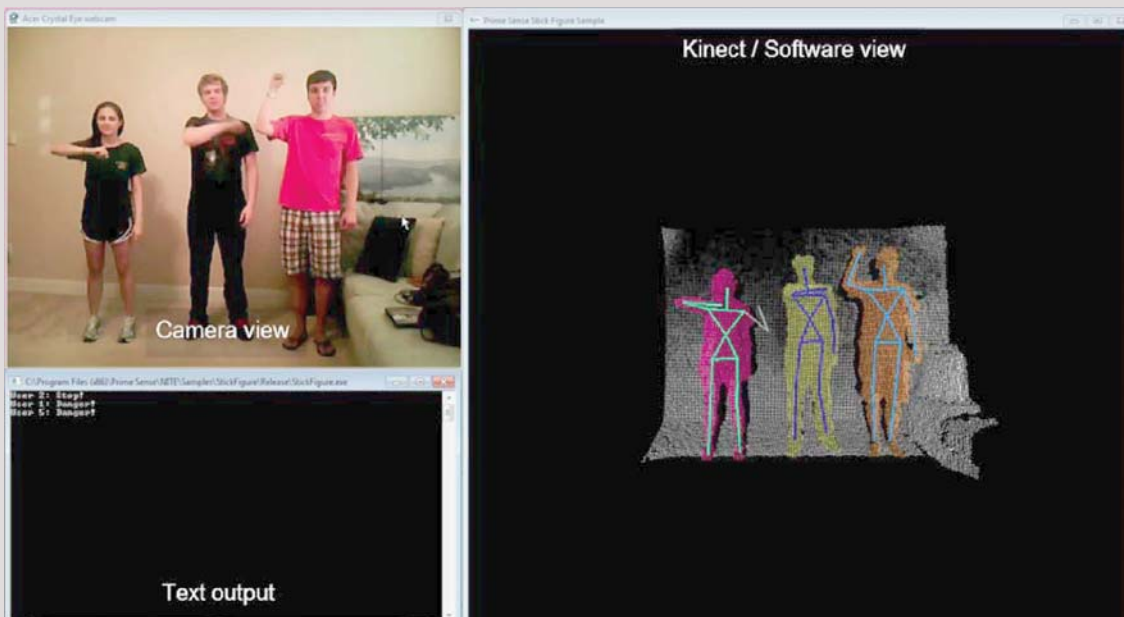

Stevens Institute of Technology

Faculty: Keith Sheppard, Eirik Hole, John Nastasi, Peter Russell

Prototypes:

This project developed a green expeditionary housing system for a 100-person combat outpost during a 6-12 month deployment period. Four relevant primary areas were designed: shelter, energy, water and waste. The team developed an integrated solution adaptable to the local requirements and not dependant on skilled labor to assemble.

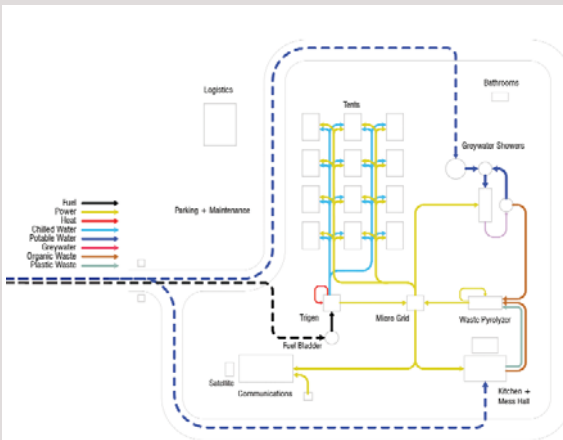

Camp Concept

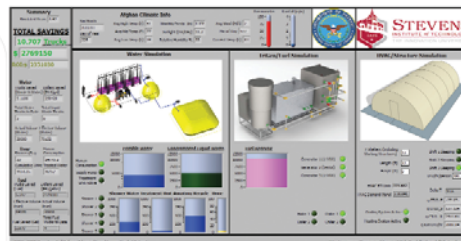

The systems approach taken so far has identified significant potential reductions in both fuel and water dependency, thus minimizing both the size and frequency of supply missions. Such missions are of critical significance in combat zones. The diagram (right) shows reductions over a 6 month period. The performance simulator (above) was developed to track consumption.

Performance Simulation

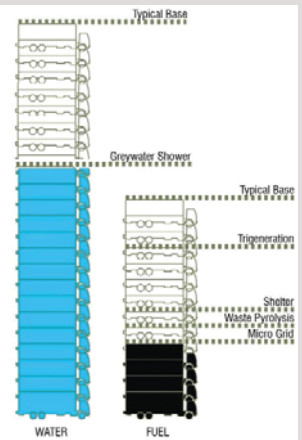

Overall Impact

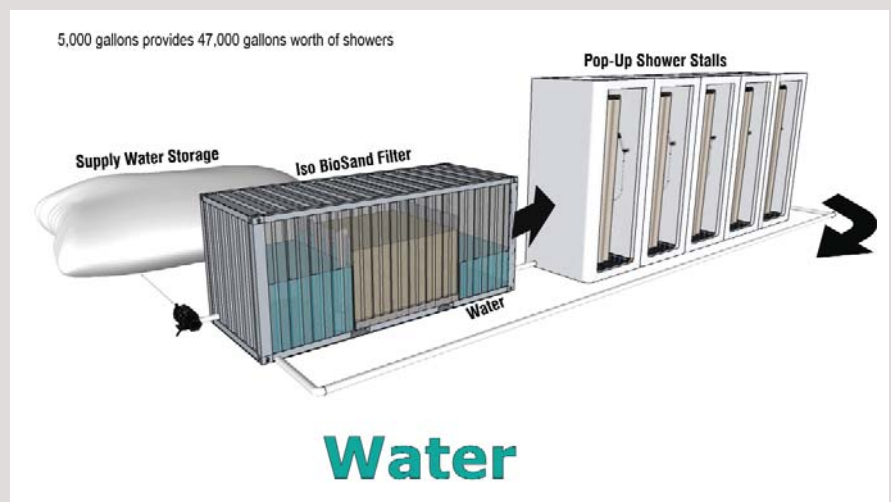

United States Air Force Academy

Faculty: Alan Mundy, LtCol Andrew Laffely USAF

Prototypes:

This project used a systems engineering approach to compare existing portable energy systems and to design a portable solar energy system for deployed military/combat units. The team considered ease of setup/teardown, power delivered, weight, and many other factors that contribute to the level of portability required. Several conceptual designs were drafted and compared to current diesel generators used by the U.S. military in both Iraq and Afghanistan. The team identified areas where diesel generators are superior and areas where solar energy systems are superior.

A combination of solar panels and a battery bank were combined into a smart grid to efficiently distribute power while decreasing cost. This was achieved by monitoring general power usage and determining when to:

- 1) decrease customer energy costs by supplying power from the solar power system during times of peak usage, or
- 2) charge the battery bank when utility power cost is cheapest or when the solar power system can divert its output power to charge the batteries, or
- 3) increase total output power of the system by combining output from the batteries with solar or utility power to satisfy short unexpected increases in customer energy consumption.



United States Coast Guard Academy

Faculty: Ron Adrezin, CAPT Jonathan Russell USCG, Richard Freeman, CDR Charles Hatfield USCG

Prototypes:

Project 1: This project designed an off-the-grid green energy system capable of providing cooling to Coast Guard land units in remote hot climates.

Project 2: This project developed a device that will sufficiently clean the propeller of a small to medium size boat without having the operator enter the water or taking the boat out of the water. The Sparkle Prop consists of 2 rotating brushes that scrape barnacles and other debris into a plastic housing. The housing is able to rotate axially, allowing it to form to the twist of each blade.

Project 3: This project developed a system to improve fuel efficiency by means of regenerative braking. The team designed a simple system that allows "bolt-on" installation and compatibility with future projects. It also maintains the full function of the original gasoline drive system if the hybrid system fails.

Project 4: This project developed an inexpensive, portable and user-friendly hull inspecting device (HID) that functions when a vessel is moving at a speed of 3 knots or less. The HID looks for any damage to the hull or parasitic devices below the water line.

Project 5: This project designed a modification of the flare tube launch mechanism for the Casa HC-144 Ocean Sentry aircraft. The current device is difficult to remove or reconfigure. The new design uses a base mount with four quick release pins for reconfiguration or removal.



United States Military Academy

Faculty: LCOL Steven Henderson USA

Prototypes:

This project analyzed current augmented/virtual reality immersive training systems and proposed new system designs in order to identify the best system that meets the following criteria:

- 1) Stimulates all sensory inputs required to achieve training objectives
- 2) Fits comfortably and securely enough to eliminate SIM sickness
- 3) Allows soldiers to train key combat tasks and develop better decision making

During pursuit of this goal, the cadet team analyzed 3 existing immersive training technologies and designed 2 new systems.



United States Naval Academy

Faculty: CAPT Kevin Rudd USNR

Prototypes:

Project 1: Improving Surge Power Capabilities

This project studied the dynamic nature of expeditionary power grids and its impact on fuel consumption in expeditionary or humanitarian-relief camps of approximately 150 people. The students demonstrated the feasibility of dynamic load balancing between two power sources.

Project 2: Personnel Tracking

This project developed a personnel tracking system to replace paper logs and report with mobile devices connected to a dedicated server system. The students implemented a basic application on a mobile device (Apple iPod Touch) that combines the barcode information on student identification cards with manually entered status information and wirelessly updates the personnel status database on a remote server.

Project 3: Portable Low-Power Water Purification

This project studied best approaches to provide water in expeditionary or humanitarian relief camps of approximately 150 people. The team researched current systems being used in expeditionary camps as well as other potential implementation options.

Project 4: Portable Renewable Sea-Based Power

This project designed and built a linearly-moving wave-action electrical power generator. The team first constructed a quarter-scale prototype model and then designed individual components to meet performance objectives.

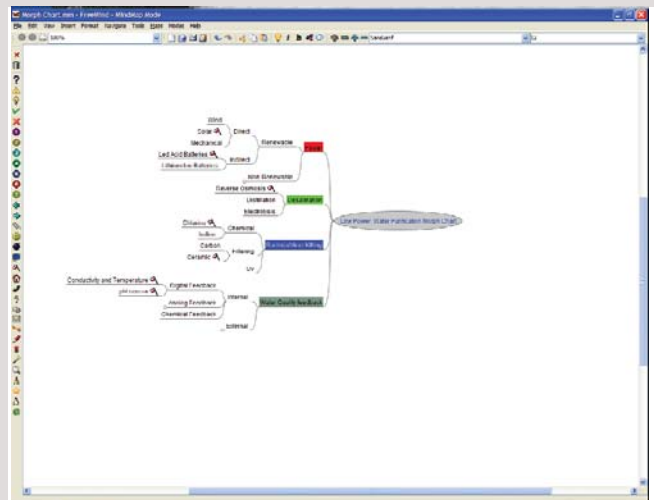
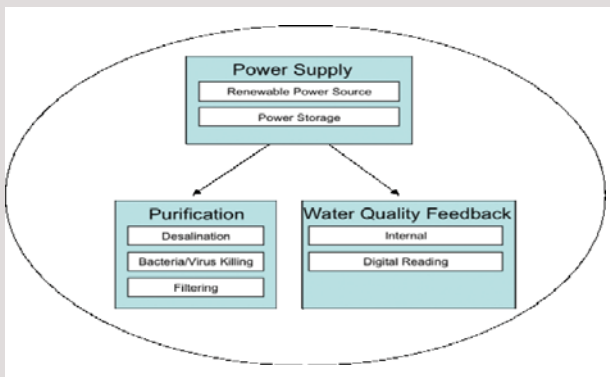

University of Maryland

Faculty: John Baras, Mark Austin

Prototypes:

Project 1: Black Box Design

This project designed a rugged black box with features that combine a flight data recorder, a cockpit voice recorder and an on-board diagnostics recorder. The system uses a solid-state drive in order to withstand extreme acceleration and provides enough space to record at least 24 hours of audio and video.

Project 2: Wireless Sensor Networks for Perimeter Security

This project developed a wireless sensor network to track intruders and monitor a secure area. Motion sensors are used to detect intrusion into the secure area and to monitor movement. A camera records an image of any intruder.

Project 3: Border Security

This project developed an efficient border security system by focusing on independent but coordinated surveillance and detection techniques. The project used the border between the U.S. and Mexico as an example in developing the system.

Project 4: Smart Tire System

This project designed a smart tire system for automobiles. It employs sensors within tires so that the vehicle control systems can react to changing conditions and reduce the probability of accidents. The sensors must endure harsh conditions within the tires while transmitting information reliably to the vehicle control systems.

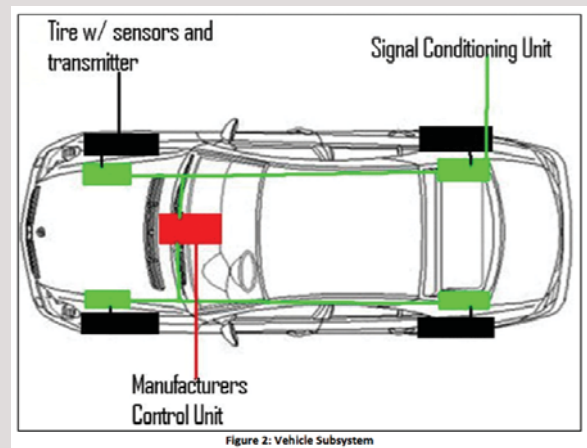
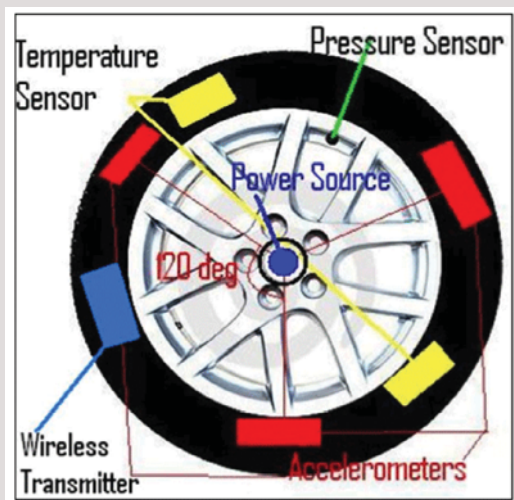
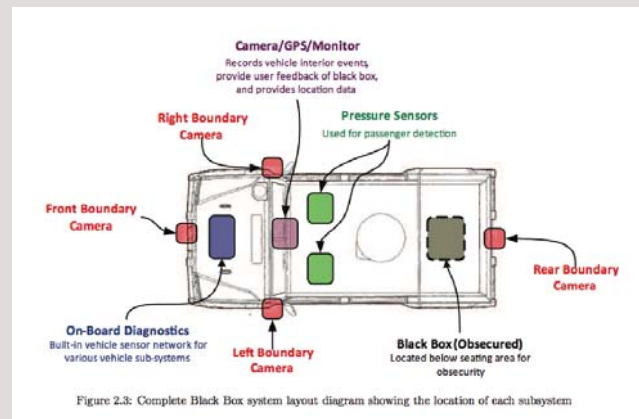
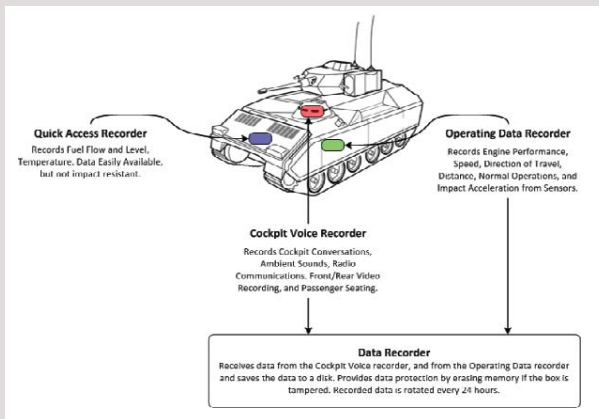

University of Virginia

Faculty: William Scherer, Reid Bailey, Garrick E. Louis, Gregory J. Gerling

Prototypes:

Project 1: Rapid Assessment of Water Quality after Natural Disasters

The Rapid Adaptive Needs Assessment kit aids in water quality assessment after emergencies like natural disasters. The kit is comprised of a smart phone, data-logger, and probes to test turbidity, total dissolved solids (TDS), pH, dissolved oxygen, and temperature. The kit samples water at determined intervals and records the data internally. The smart phone transmits the data to the appropriate military base. Users can monitor the database to determine which water sources are safe and which sources are experiencing significant changes in quality over time.

Project 2: Using Electro-active Polymers to Simulate the Sense of Light Touch and Vibration in a Virtual Reality Environment

This project constructed a tactile feedback system using electro-active polymers to create light touch and vibratory sensation to the fingertips, and DC motors to constrict the distal digit for a virtual reality environment. This hand tracking method ties absolute tracking of the user's palm with relative tracking of individual fingers. The tracking system was verified using experiments designed to confirm the accuracy and usability of the device.

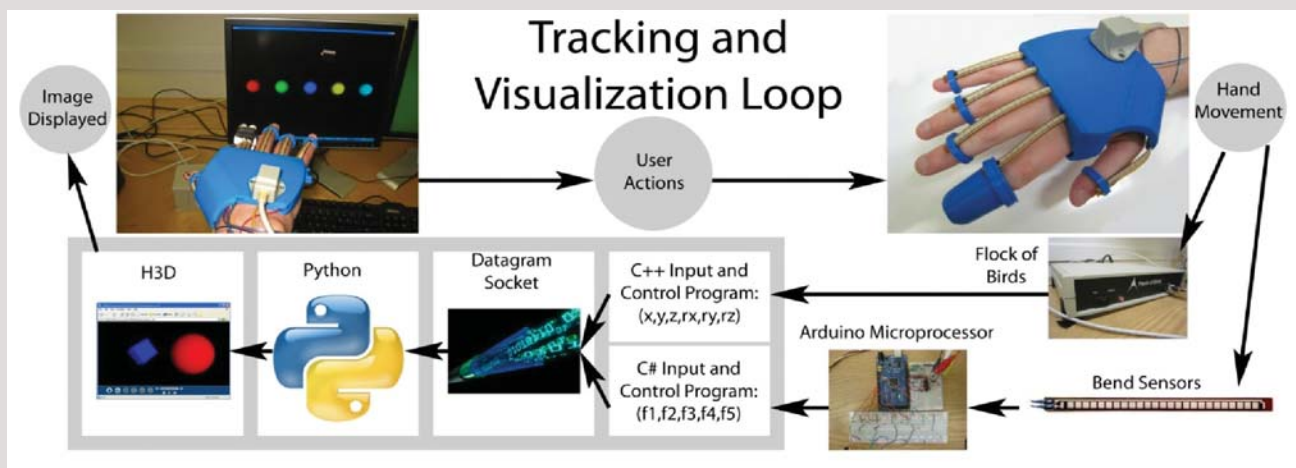

Wayne State University

Faculty: Walter Bryzik, Kyoung-Yun Kim, Darin Ellis, Dean Pichette, Golam Newaz, Gene Rivin, Ming-Chia Lai, Kristi Verbeke

Prototypes:

Project 1: Solar Powered Field Medical Facility

This project designed a disaster relief medical facility that runs completely on alternative energy, a solar power system with backup fuel cell generator. The final product uses solar power as its source of energy during daylight hours and performs electrolysis of water to generate hydrogen. The hydrogen is used as source of fuel for the fuel cell that provides energy at night.

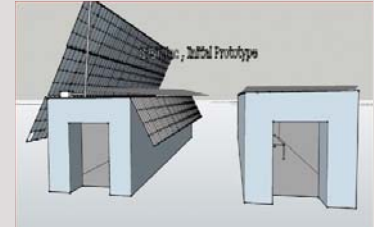

Project 2: Manual Power Generator

This project designed a portable bicycle-type generator to provide electrical power for small devices.

Project 3: Mobile Sanitation Station

This project designed a portable sanitation station, including toilets and showers, to be used when clean water is not readily available.

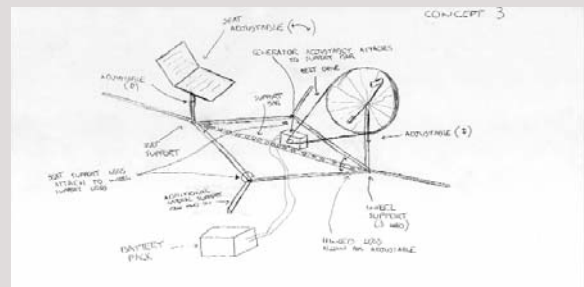

Project 4: Wind Powered Generator

This project designed an emergency power generator that produces electricity from wind power. The generator has physical characteristics and packaging that would enable it to be quickly deployable from a helicopter so as to be completely independent of road transport.

Project 5: PEAK Installation

This project designed a functional Pre-Positioned Expeditionary Assistance Kit (PEAK) that can provide humanitarian relief services for ten people in the early days of a natural or man-made crisis. The kit includes:

- Water purification and storage for drinking and hygiene purposes
- Climate-controlled shelter
- Cooker
- Power generation for the entire kit utilizing a renewable energy source
- Back-up fossil fuel power generator

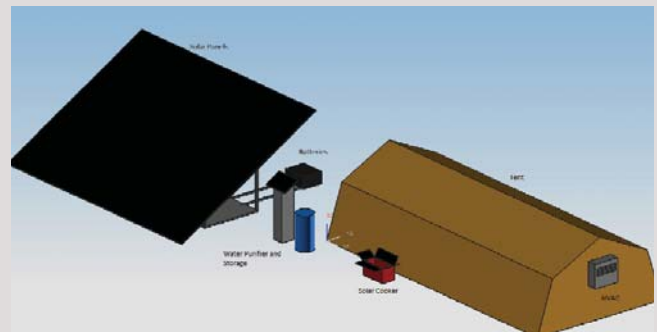
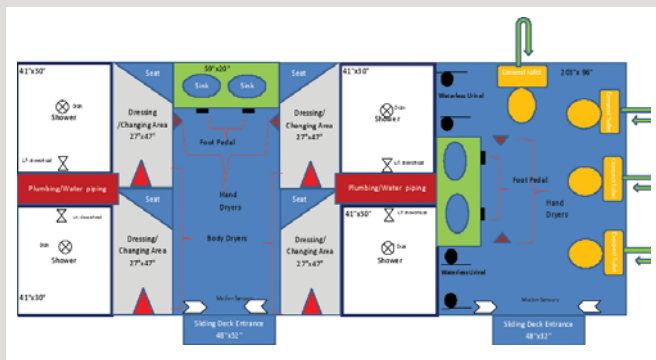
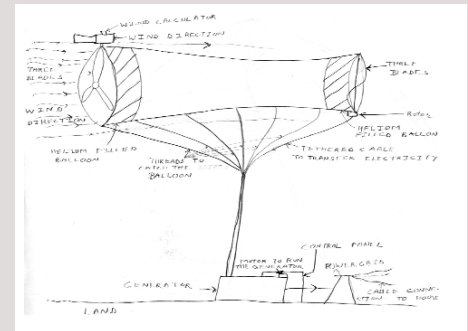



SYSTEMS ENGINEERING
Research Center

Building Systems Engineering Education and Workforce Capacity

ACKNOWLEDGEMENTS

This publication acknowledges the original research conducted by the SERC research team and the contributions by the SERC sponsors, as well as the many faculty, students, and mentors who participated.

Research Team:

Stevens Institute of Technology
Elisabeth McGrath
Christian Jurado
Mark Ardis

Columbia University – Teachers College
Susan Lowes
Sophie Lam

Collaborating Schools:

Air Force Institute of Technology: David Jacques
Auburn University: David Umphress, Alice Smith, John Hamilton
Missouri University of Science and Technology: Cihan Dagli, Steven Corvis, Ivan Guardiola
Naval Postgraduate School: Dave Olwell, Clifford Whitcomb, Diana Angelius, Gary Langford, Gregory Miller, Ali Rodgers, Mark Stevens
Pennsylvania State University Great Valley: James Nemes, Sven Bilen, Elizabeth Kirsenswether, Robert Capuro, Mary Brannon
Southern Methodist University: LiGuo Huang, Nathan R. Huntoon
Stevens Institute of Technology: Keith Sheppard, Eirik Hole, John Nastasi, Peter Russell
United States Air Force Academy: Alan Mundy, LtCol Andrew Laffely USAF
United States Coast Guard Academy: Ronald Adrezin, Richard Freeman, CDR Charles Hatfield USCG, CAPT Jonathan Russell USCG
United States Military Academy: LCOL Steven Henderson USA
United States Naval Academy: CAPT Kevin Rudd USNR
University of Maryland: John Baras, Mark Austin
University of Virginia: William Scherer, Reid Bailey, Garrick E. Louis, Gregory J. Gerling
Wayne State University: Walter Bryzik, Darin Ellis, Kyoung-Yun Kim, Dean Pichette, Golam Newaz, Gene Rivin, Ming-Chia Lai, Kristi Verbeke

Sponsors:

Assistant Secretary of Defense for Research and Engineering:
Laura Adolfie, G. Richard Freeman, Don Gelosh, Scott Lucero, Caryl Rowland, John Seely

April 2012



SYSTEMS ENGINEERING Research Center

The SERC offices are located at:
Stevens Institute of Technology
The Babbio Center
Hoboken, NJ 07030
Phone: 201-216-8300

For more information about the SERC,
please visit the SERC website at
www.SERCuarc.org

The SERC Collaborators

University or Research Organization

- 1 Stevens Institute of Technology
- 2 University of Southern California
- 3 Air Force Institute of Technology
- 4 Auburn University
- 5 Carnegie Mellon University
- 6 Fraunhofer Center at University of Maryland
- 7 Georgetown University
- 8 Georgia Institute of Technology
- 9 Purdue University
- 10 Missouri University of Science and Technology
- 11 Naval Postgraduate School
- 12 North Carolina Agricultural & Technical State University
- 13 Pennsylvania State University
- 14 Southern Methodist University
- 15 Texas A&M University
- 16 Texas Tech University
- 17 University of Alabama in Huntsville
- 18 University of California - San Diego
- 19 University of Maryland
- 20 University of Massachusetts Amherst
- 21 University of Virginia
- 22 Wayne State University

