



Calhoun: The NPS Institutional Archive
DSpace Repository

Faculty and Researchers

Faculty and Researchers' Publications

1988-12

Impulsive Loading from a Bare Explosive Charge in Space

Falcovitz, Joseph; Fuhs, Allen E.

AIAA

Falcovitz, Joseph, and Alien E. Fuhs. "Impulsive loading from a bare explosive charge in space." *Journal of Spacecraft and Rockets* 25.6 (1988): 400-404.
<http://hdl.handle.net/10945/69590>

This publication is a work of the U.S. Government as defined in Title 17, United States Code, Section 101. Copyright protection is not available for this work in the United States.

Downloaded from NPS Archive: Calhoun



Calhoun is the Naval Postgraduate School's public access digital repository for research materials and institutional publications created by the NPS community. Calhoun is named for Professor of Mathematics Guy K. Calhoun, NPS's first appointed -- and published -- scholarly author.

Dudley Knox Library / Naval Postgraduate School
411 Dyer Road / 1 University Circle
Monterey, California USA 93943

<http://www.nps.edu/library>



Impulsive Loading from a Bare Explosive Charge in Space

Joseph Falcovitz* and Allen E. Fuhs†
Naval Postgraduate School, Monterey, California

Consider a planform target subjected to a normal impact of explosive products generated by detonating a bare charge in space. It is suggested that the loading impulse may be approximated by the total momentum of that portion of the fluid which impacts at the target. By assuming an impulsive dynamic response and that the ensuring damage is proportional to the kinetic energy imparted to the structure by the blast, a particularly simple law results: damage $\sim W^2/R^4$ (where W is the charge mass and R the range). This model is an idealization of a solar panel (or antenna) extended in a paddle-like fashion from a relatively rigid and massive core structure. It is also shown that this law implies that no advantage can be realized by rearranging the mass of a single bare charge in a cluster configuration of smaller subcharges that are dispersed and detonated via an idealized "isotropic" scheme.

Nomenclature

C	= coefficient in charge mass/range/damage relationship, $m \cdot kg^{-1/2}$
D_{CJ}	= speed of propagation of detonation wave at CJ point, m/ms
I	= impulse per unit area of target, $kg/m \cdot ms$
\hat{I}	= dimensionless impulse, $\hat{I} = I(R) [4\pi R_0^2 / W(2Q_0)]^{1/2}$
h	= beam thickness, m
L	= length of cantilever beam, m
m	= Lagrange mass coordinate, kg
M_p	= moment per unit length of plastic hinge, MPa/m^2
N	= number of subcharges in a cluster configuration
P	= pressure, MPa
P_s	= surface pressure, MPa
Q_0	= explosive energy per unit mass, MJ/kg
R	= range from center of charge, m
R_0	= radius of spherical charge, m
S	= speed of propagation of shock wave, m/ms
t	= time, ms
U	= flow velocity, m/ms
V	= velocity imparted to target by loading impulse, m/ms
W	= charge mass, kg
Y	= plastic yield stress, MPa
Z	= total momentum of an explosive charge, $kg/m \cdot ms$
α	= coefficient for dynamic pressure recovery
β	= conversion multiplier for scaled impulse in air
γ	= specific heat ratio
γ_{CJ}	= specific heat ratio of explosive products at CJ point
δ	= conversion multiplier for scaled range in air
θ	= plastic rotation angle of cantilever beam
κ	= impact approximation impulse coefficient (presently $\kappa = 1$)
μ	= beam mass per unit area, kg/m^2
ρ	= fluid density, kg/m^3
ρ_p	= beam density, kg/m^3
φ	= mid-area angle of subcharge spherical cap

Introduction

THE advent of space-based weapon systems in our times has raised the prospects of future "Star Wars" conflicts, rendering the potential use of explosive devices against space targets a present-day engineering reality. For obvious reasons, the warhead of choice in space seems to be of the fragmentation type. The effectiveness of fragments is unhampered by the space environment (lack of air may even be helpful). By contrast, bare charges in space are considerably less efficient than in air. We contend that blast effects in space may still be of practical interest, primarily since fragmentation warheads will contribute to the existing—and potentially hazardous—population of space debris.

One may wonder why explosions in air are more effective than in outer space, since in air, as in space, the same amount of chemical energy is released through the detonation process. The explanation is that the difference is in the much larger mass involved in the air blast, relative to the bare charge mass. For a more detailed explanation, we consider the process by which an explosive-driven blast wave is generated in air. The explosive products effectively constitute a rapidly expanding spherical piston (typical initial speed around 6 km/s), which drives an intense shock wave into the surrounding air. At a typical range of $100 R_0$ (and with an air density equal to about $1/1000$ of the charge density), the mass of air entrained by the shock is about 1000 times the charge mass. Thus, the highly concentrated initial explosive energy has spread over a much larger mass than that of the charge, via the mechanism of wave propagation in a compressible media, resulting in an increased momentum.

It is also worthwhile noting that explosive products in space typically attain hypersonic speed prior to impacting at the target. The flow velocity in an air blast is typically subsonic or somewhat supersonic. It is thus expected that the actual gasdynamic interaction between the blast flow and a stationary target will be fundamentally different in these two cases.

An analysis of the blast loading on a target can be performed at any of several levels of complexity. At the simplest level, one consults available compilations of experimental and computational data, which are generally presented in a universally applicable nondimensional form. A comprehensive treatment of explosions in air, including references to a large number of specific studies, is the book by Baker.¹ At the most complex level, one can conduct experimental tests or apply a general-purpose hydrocode in order to study the blast loading

Received May 19, 1986; revision received Jan. 20, 1987. This paper is declared a work of the U.S. Government and is not subject to copyright protection in the United States.

*Senior Research Associate, Space Systems Academic Group. Member AIAA.

†Distinguished Professor (Emeritus); Former Chairman, Space Systems Academic Group. Former President AIAA; Fellow AIAA.

of specific charge/target configurations. A state-of-the-art hydrocode that has been applied to air blast computations is PISCES 2DELK.²

We are not aware of any published experimental or computational studies of blast loading in space. It is possible to adapt a hydrocode such as PISCES 2DELK² to the computation of explosive blast loading in space. However, we propose a much simpler approach using an impact approximation that is deemed suitable for preliminary estimates. This model may also serve as a tentative correlation for detailed experimental or computational data on blast loading in space, when such data become available.

The key idea of the present model is a combination of the assumption that target dynamic response is related primarily to total blast impulse and the physically plausible notion that this impulse is equal to the total momentum of that portion of the expanding explosive products impacting at the target. We clarify the sense in which this simple notion constitutes an approximation to a proper gasdynamic analysis of the interaction between the fluid and the target: we also present an illuminating comparison between impulsive blast loading in air and in space.

In order to demonstrate the charge mass/range/damage relationship implied by our impact blast approximation, we chose a simple target model: a cantilever beam with a rigid, perfectly plastic stress-strain relationship. It represents an extended structural element such as a solar panel or an antenna. We make use of studies conducted by Mentel³ and Bodner and Symonds⁴ that show that, by and large, the effect of accelerating the beam impulsively is to cause a rotation about a plastic hinge at the point of support. The final angle of rotation is generally proportional to the initial kinetic energy, so that equating damage with that angle results in the damage being proportional to the square of the impulse imparted to the target by the blast loading.

Our charge mass/range/damage relationship may imply some far-reaching conclusions when applied to the analysis of a more general configuration than the single-charge/single-target case. We present a simple analysis of a submunition configuration of *N* bare charges, concluding that it seems to have no advantage in efficiency, relative to a single charge of equal mass.

We conclude this introduction by listing the main assumptions made in the present study:

- 1) Blast loading and target response are uncoupled, since typically the target mass is much larger than the mass of that portion of the explosive products impacting it.
- 2) The dynamic target response depends solely on the total (time-integrated) impulse.
- 3) The target is a rigidly supported cantilever.
- 4) The charge is a sphere detonated at its center. The expansion is spherically symmetric.
- 5) The target surface is normal to the local flow vector.
- 6) The target orbital velocity relative to the center of the charge is negligible compared with the velocity of the expanding products.

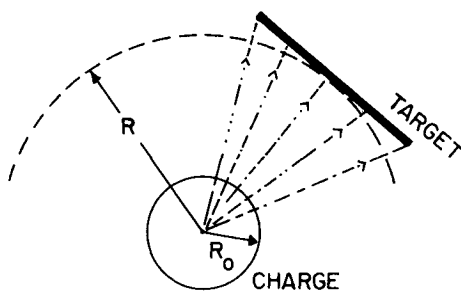

Fig. 1 Impact blast loading.

Impact Blast Loading

Consider the expanding explosive products impacting at a target as shown in Fig. 1. Regarding the fluid as an ensemble of noninteracting particles moving at velocity $U(R,t)$ and assuming a no-rebound normal impact at the surface, the pressure-time history is

$$P_s(t) = \rho(R,t) [U(R,t)]^2 \quad (1)$$

How is this simple impact mechanism related to the actual gasdynamic interaction between the expanding explosive products and the target? When a target is located at a range of at least several charge radii, two features in the freestream of the oncoming fluid are significant: the flow is highly hypersonic (Mach number 20 or higher) and the static pressure is very small, which means that $P + \rho U^2 \approx \rho U^2$. These facts were borne out by a numerical computation we performed for a typical high explosive characterized by the following parameters:

$$\begin{aligned} \rho_0 &= 1800 \text{ kg/m}^3, & D_{CJ} &= 8 \text{ m/ms} \\ \gamma_{CJ} &= 3, & Q_0 &= D_{CJ}^2 / [2(\gamma_{CJ}^2 - 1)] \\ & & &= 4 \text{ MJ/kg} \end{aligned} \quad (2)$$

The spherically expanding flow was computed by integrating the Euler equations for isentropic flow via a high-resolution conservative finite-difference scheme.⁵ The initial conditions were the self-similar flowfield of a just-detonated spherical charge given by Taylor.⁶ The code GRP with which the computation was performed is described and outlined in a recent report.⁷

Consider the flow at a stationary target that begins at the moment of arrival of the expanding explosive products (Fig. 2). A qualitative description of the ensuing flow pattern is made by observing its evolution in time. Immediately following the initial (normal) impact, the fluid is stopped at the target by a backward-propagating shock wave reflected from the surface. Since the target is finite, the fluid between the shock and the surface is accelerated laterally and streamlines

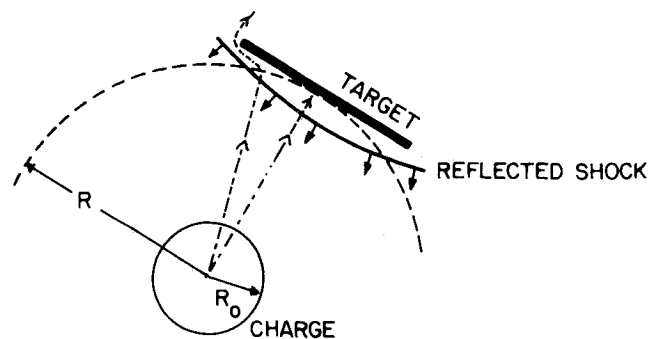

Fig. 2 Shock reflection at impact phase.

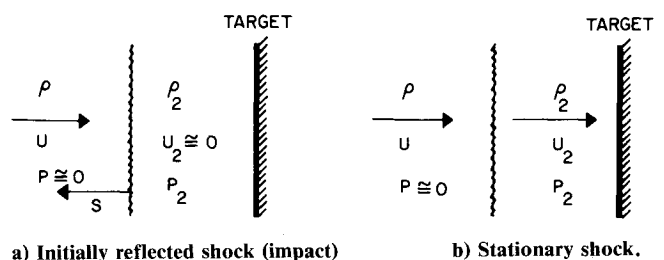

Fig. 3 Limiting cases of shock reflection.

that tend to curve around the target are formed. If the oncoming flow is stationary, the flowfield will evolve toward the familiar configuration of a detached bow shock positioned at a relatively narrow standoff distance from the surface.

Let us find the postshock pressure in these two limiting phases. In the initial phase, the fluid is stopped at the target by a reflected shock (Fig. 3a) and, in the pseudostationary phase (Fig. 3b), the shock is stationary. The governing equations in the reflected shock case are

$$\begin{aligned}\rho(U+S) &= \rho_2 S \\ \rho(U+S)^2 &= P_2 \\ \rho(\gamma+1)/(\gamma-1) &= \rho_2 \quad (\text{strong shock})\end{aligned}\quad (3)$$

where the unknowns are ρ_2 , P_2 , and S .

The equations for the stationary shock case are

$$\begin{aligned}\rho U &= \rho_2 U_2 \\ \rho U^2 &= P_2 + \rho_2 U_2^2 \\ \rho(\gamma+1)/(\gamma-1) &= \rho_2 \quad (\text{strong shock})\end{aligned}\quad (4)$$

where the unknowns are ρ_2 , U_2 , and P_2 . Thus, solving for the postshock pressure in the two cases represented by Eqs. (3) and (4), we get the following pressure recovery expression:

$$\begin{aligned}P_2 &= \alpha \rho U^2 \\ \text{Reflected shock} \quad \alpha &= [(\gamma+1)/2]^2 \\ \text{Stationary shock} \quad \alpha &= 2/(\gamma+1)\end{aligned}\quad (5)$$

Since the gas is not dense, the effective value of γ is probably around 1.4, so that setting $\alpha=1$ is an approximation commensurate with the overall crudeness of the present impact blast model. Furthermore, the flow in the layer between the shock and the target is low subsonic (at least away from the target edges), so that the postshock pressure is a reasonable substitute for the surface pressure. Also, $\alpha=1$ is an appropriate approximation where the flow is so rarefied that it is collisionless. In this limit, $\alpha=1$ corresponds to full thermal accommodation of re-emitted molecules from a presumably cold surface.

The foregoing analysis constitutes a justification of the impact approximation to the surface pressure [Eq. (1)]. Now, we turn to the task of evaluating the impulse defined as the time-integrated surface pressure. Using the impact approximation of Eq. (1), the impulse is given by

$$I(R) = \int_0^\infty P_s(t) dt = \int_0^\infty \rho(R,t) [U(R,t)]^2 dt \quad (6)$$

Let us introduce a Lagrange mass coordinate m that enables a transformation from the Euler system (R,t) to the Lagrange system (m,t) . The differential relation associated with this transformation at constant R is

$$dm = 4\pi R^2 \rho(R,t) U(R,t) dt \quad (7)$$

Since it is assumed that the fluid is not accelerated at any (R,t) in the range of interest for blast loading, the velocity $U(R,t)$ can be regarded as function *solely of the mass coordinate*, so that $U(R,t) = U(m)$. Using Eq. (7), we are then able to cast the impact blast equation (6) in the following simple and physically appealing form:

$$\begin{aligned}I(R) &= Z/4\pi R^2 \\ Z &= \int_0^W U(m) dm\end{aligned}\quad (8)$$

The total momentum Z is thus a constant that can be evaluated for any specific explosive charge by numerical integration. We performed this computation with the code GRP.⁷ In doing so for the typical explosive [Eq. (2)], we found out that Eq. (8) was a good approximation to the total impulse at ranges as low as $R=3R_0$. Furthermore, it was found that Z could be approximated by the maximum attainable momentum for the given charge mass and energy $W(2Q_0)^{1/2}$ to within about 6%. Apparently, the total momentum is not overly sensitive to the exact velocity distribution function $U(m)$, so that assuming a value of Z appropriate to the uniform distribution $U(m) = (2Q_0)^{1/2}$ is a reasonable approximation. Thus, we finally arrive at the following closed-form approximation for the blast impulse:

$$\begin{aligned}I(R) &= \kappa W(2Q_0)^{1/2}/4\pi R^2 \\ \kappa &= 1\end{aligned}\quad (9)$$

where the coefficient κ is retained in order to suggest that its value be determined from detailed experimental or computational data, in the event that such data become available. At present, our best estimate is $\kappa=1$.

There is one comparison, however, that can readily be made with the available data. We refer to impulsive blast loading in air, such as given by Baker (Ref. 1, Fig. 6.3 in the supplement). The comparison is conveniently made with a non-dimensional form of Eq. (9), which is rewritten as

$$\hat{I} = I(R) \frac{4\pi R_0^2}{W(2Q_0)^{1/2}} = \left(\frac{R}{R_0}\right)^2 \quad (10)$$

The air blast data have to be converted to the same normalization scheme as in Eq. (10) before the comparison can be made. Considering the definition of \hat{I} in Eq. (10) and the definition of scaled range and air blast impulse (Table 6.2 of Ref. 1), this conversion is done by multiplying the scaled air impulse and range by the following coefficients (sea-level air is assumed):

Impulse multiplier

$$\beta = 3(2\gamma)^{-1/2} \left(\frac{4\pi}{3}\right)^{1/2} \left(\frac{P_a}{\rho_a Q_0}\right)^{1/6} \left(\frac{\rho_a}{\rho_0}\right)^{1/2} = 0.01204$$

Range multiplier

$$\delta = \left(\frac{4\pi}{3}\right)^{1/2} \left(\frac{\rho_0 Q_0}{P_a}\right)^{1/2} = 67.06 \quad (11)$$

where $\rho_a = 1.3 \text{ kg/m}^3$, $P_a = 0.1 \text{ MPa}$, and $\gamma = 1.4$.

The blast impulses in air and in space are shown in Fig. 4. At ranges larger than about 10 charge radii, we note that the air blast impulse is higher than the space impulse and the gap widens as the range increases. This observation is consistent with the qualitative explanation given in the introduction, which attributed this effect to the increase in the entrained air mass at higher ranges. At ranges lower than 10 charge radii, the air mass is relatively insignificant, so that one may expect the blast impulses in air and in space to be comparable. Indeed, the inverse-square variation of impulse with range is apparent for the air blast at low range. In absolute values, however, the low-range space impulse is higher by a factor of about 1.7. This might be interpreted as indicating that choosing $\kappa=1/1.7$ would be the appropriate "calibration." However, we do not propose to do so, since we are not able to trace the various factors affecting the low-range impulse as given by Baker;¹ they may somehow depend on the presence of air, as well as on other parameters such as target size and the equation of state of the explosion products.

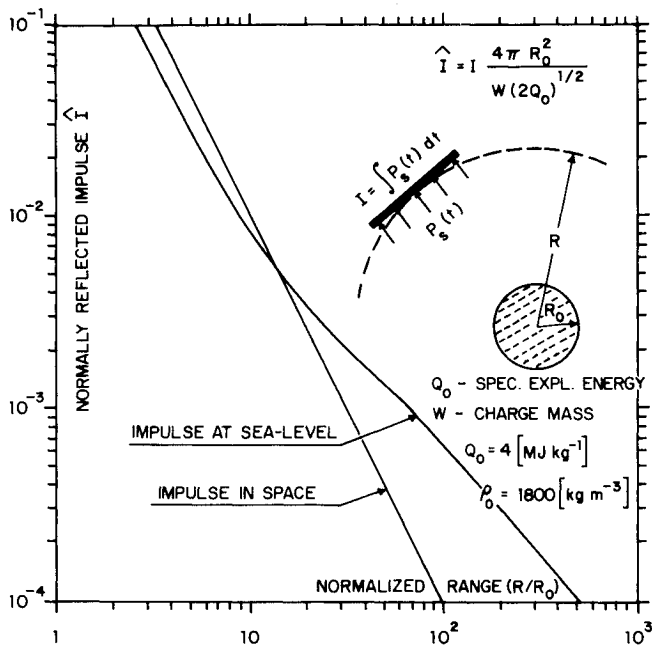

Fig. 4 Impulse of normally reflected blast wave at sea-level and in space.

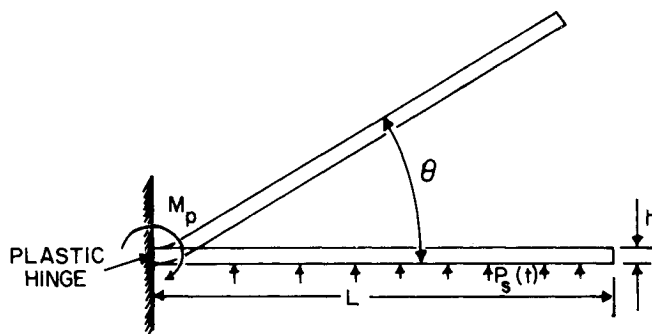

Fig. 5 Cantilever beam with plastic hinge.

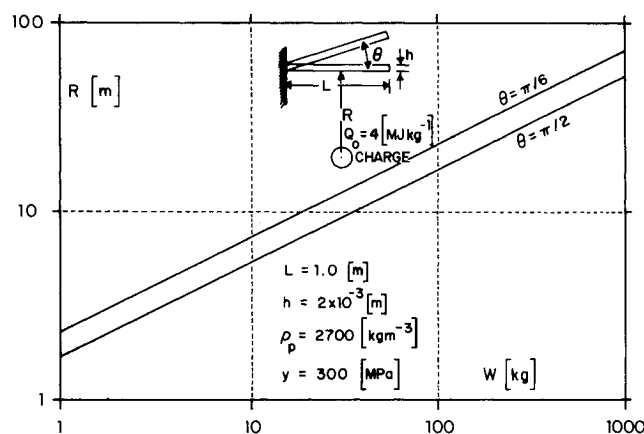

Fig. 6 Charge mass/range/damage curves for cantilever beam.

Target Dynamic Response

For the sake of constructing representative charge mass/range/damage relations from our impact approximation to the blast impulse [Eq. (9)], we suggest a simple idealized structure as the target model. It is a cantilever beam made of a metal characterized by a rigid, perfectly plastic stress-strain relation. This model is supposed to represent an extended spacecraft component such as a solar panel or an antenna. The

core structure is assumed to be much more massive and rigid than the extended structural element, so that the cantilever can be idealized as being rigidly supported. The sole dynamic and structural parameters are hence those of the cantilever.

For this purpose, we make use of an experimental and theoretical investigation of uniform cantilever beams subjected to impulsive loading that was conducted by Mentel.³ Aluminum alloy beams were held in a massive support that was gliding along a rail at speed V until it was abruptly stopped by a very massive anvil. After the system came to rest, the beams were observed to have rotated through an angle θ about the point of support, with little deformation elsewhere (Fig. 5).

The theoretical model suggested by Mentel³ for predicting $\theta(V)$ can be described as comprising two stages. Immediately following the impact, the beam commences rotating rigidly about the support point, with an angular momentum equal to the precollision moment of momentum about that point. This application of the principle of conservation of moment of momentum entails an abrupt redistribution of the velocity in the beam, with the velocity being proportional to the distance from the support and the tip moving at $1.5V$. The angle θ is subsequently determined from the requirement that the rotational kinetic energy be dissipated as plastic hinge work $M_p\theta$. The resulting $\theta(V)$ expression is

$$\theta = \frac{3}{8} \mu L V^2 / M_p \tag{12}$$

We now make one more step in formulating the model, in that we postulate that the angle θ is a measure of damage. Using the following expressions for M_p , μ , and V ,

$$M_p = \frac{1}{4} Y h^2, \quad \mu = \rho_p h, \quad V = I(R) / \mu \tag{13}$$

we get from Eqs. (9) and (12) the following charge mass/range/damage (W - R - θ) relationship:

$$R = C W^{1/2}$$

$$C = \left[\left(\frac{3}{16\pi^2\theta} \right) \left(\frac{LQ_0}{\rho_p Y h^3} \right) \right]^{1/4} \tag{14}$$

Using the data for the typical explosive [Eq. (2)] and the following data for a specific aluminum beam, we get for this sample case:

$$h = 0.002 \text{ m} \quad L = 1.0 \text{ m}$$

$$\rho_p = 2700 \text{ kg/m}^3 \quad Y = 300 \text{ MPa}$$

$$C = 1.85 \theta^{-1/4} \text{ m} \cdot \text{kg}^{-1/2} \tag{15}$$

The charge mass/range/damage relationship corresponding to this sample case is depicted in Fig. 6.

Cluster Configuration

In a cluster configuration, the gain in damage is presumably a result of a favorable design tradeoff between reduced charge mass and reduced range. Can such a gain be achieved for a space system, assuming the charge mass/range/damage law [Eq. (14)] to hold? It can be shown that by adopting some simple strategy of submunition dispersion and initiation, Eq. (14) implies no gain in target damage.

Let us assume, for the sake of a reasonably simple analysis, that dispersion and initiation of subcharges take place according to the following scheme:

- 1) The N subcharges appear to fan out from a common virtual center, moving at equal speeds. At subsequent times, their centers are uniformly distributed over an expanding spherical envelop.

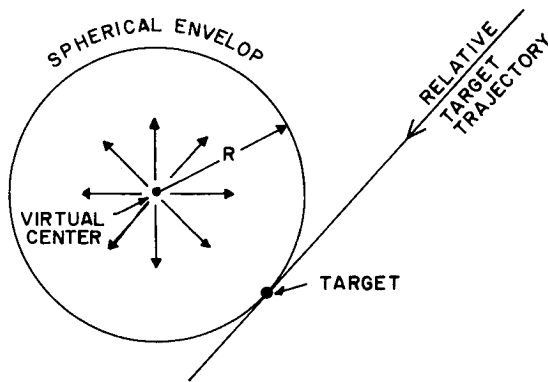

Fig. 7 Target intercept at closest approach.

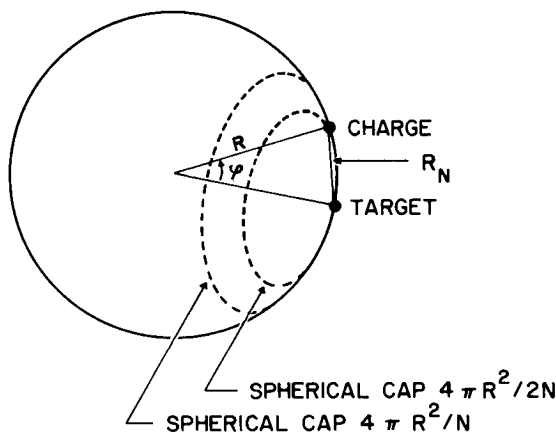

Fig. 8 Spherical cap surrounding the target.

2) The target moves at a constant velocity relative to the virtual center. Its point of closest approach to that center is at range R .

3) The timing for dispersion is chosen so that the target intersects (tangentially) with the spherical envelop at the point of closest approach (Fig. 7). This is also the point at which the blast from a single-charge configuration detonated at the virtual center will have impacted the target.

4) All submunitions are detonated at this "moment of closest approach."

5) It is assumed that each spherical cap of area $4\pi R^2/N$ will contain one, and only one, subcharge. The probability of the charge location on that cap is assumed to be uniformly distributed. The expected location on the cap is hence that latitude line φ dividing the cap into two parts of equal area (Fig. 8).

6) It is assumed that the target is subjected to the blast of a single subcharge, which is located on the mid-area latitude φ of the spherical cap that surrounds the target (Fig. 8).

Since the area of the spherical cap subtended by φ is $4\pi R^2/(2N)$, the angle φ is given by

$$\sin(\varphi/2) = (2N)^{-1/2} \quad (16)$$

We seek a comparison between the deflection θ for a single charge (W, R) and the deflection θ_N in the submunition case [$W_N = W/N$, $R_N = 2R \sin(\varphi/2)$]. From the charge mass/range/damage law [Eq. (14)], using also Eq. (16), we get

$$(\theta_N/\theta) = (W_N/W)^2 (R/R_N)^4 = 1/4 \quad (17)$$

Consequently, there is no potential gain in a tradeoff between charge mass and range for a cluster configuration with the aforementioned dispersion scheme. The factor $1/4$, along with the mass overhead inherent in constructing a multicharge configuration, indicates that, in causing blast damage, a single

charge is more effective than an equal-mass isotropically dispersed cluster.

Discussion and Conclusions

Our analysis pertains to a bare explosive charge initiated at a point of closest approach to the target. We have shown that the loading impulse on a planform target is given by the impact approximation [Eq. (9)], which states that the impulse is proportional to the charge mass and inversely proportional to the range squared. The impulse in space has been compared with impulse in air at sea level. It was found that the two are quite comparable at close range (10 charge radii or less), exhibiting identical variation with range. At far ranges, the impulse in air is the higher one. This is consistent with the notion that spreading the explosive energy over a larger air mass results in larger momentum (and hence reflected impulse).

We then proceeded to develop the charge mass/range/damage law [Eq. (14)] for an impulse-responsive target, which states that blast damage is proportional to the square of the charge mass and inversely proportional to the fourth power of the range. These results were obtained by introducing extensive simplifications in the analysis of the gasdynamic interaction and the dynamic target response. We have further shown that this damage law also implies that no gain can be achieved by an idealized cluster configuration of bare subcharges relative to a single charge of equal total mass.

It is worthwhile noting that all of the assumptions introduced in the course of formulating the impact blast approximation and the structural dynamic response to impulsive loading imply that target damage is overestimated. The only exception is the approximation in setting $\alpha = 1$, which can be readily rectified by assigning to α the reflected shock value given in Eq. (5). Furthermore, we assumed that the pressure at the midpoint of the target is the pressure everywhere on the target. Due to flow around the edges, the average pressure is lower than the midpoint pressure. Also, targets are not everywhere normal to the flow (and the charge/target attitude is not a design parameter). Oblique impact obviously entails reduced target loading. In the area of structural dynamic response, a time-distributed loading function generally delivers less kinetic energy to the structure than an impulsive loading of equal total impulse, resulting in reduced deformation (damage). Thus, while the present model may be regarded as an overestimate when applied to a sure-fail analysis, it is particularly suitable in determining a sure-safe range.

Acknowledgment

The GRP code is a product of mutual research conducted by Prof. M. Ben-Artzi and one of us (J. Falcovitz). Its use in the current study is gratefully acknowledged.

References

- Baker, W.E., *Explosions in Air*, University of Texas Press, Austin and London, 1973.
- Hancock, S.L., "PISCES 2DELK Theoretical Manual," Physics International Co. San-Leandro, CA, Aug. 1985.
- Mentel, T.J., "The Plastic Deformation Due to Impact of a Cantilever Beam with an Attached Tip Mass," *Journal of Applied Mechanics*, 1958, pp. 515-524.
- Bodner, S.R. and Symonds, P.S., "Experimental and Theoretical Investigation of the Plastic Deformation of Cantilever Beams Subjected to Impulsive Loading," *Journal of Applied Mechanics*, 1962, pp. 719-728.
- Ben-Artzi, M. and Falcovitz, J., "An Upwind Second-Order Scheme for Compressible Duct Flows," *SIAM Journal on Scientific and Statistical Computing*, Vol. 7, 1986, pp. 744-768.
- Taylor, G.I., "The Dynamics of the Combustion Products Behind Plane and Spherical Detonation Fronts in Explosives," *Proceedings of the Royal Society of London*, Vol. CC, Ser. A, 1950, pp. 235-247; also *The Scientific Papers of Sir Geoffrey Ingram Taylor*, Vol. III, edited by G.K. Batchelor, Cambridge Press, London, 1963, pp. 465-478.
- Falcovitz, J., "Impulsive Loading from a Bare Explosive Charge in Space," Naval Postgraduate School, Monterey, CA, Rept. NPS72-86-004 CR, Dec. 1986.