

Adrenergic Regulation of Insulin  
Secretion in the Cold Acclimated Rat

By

George Mitri Barody, B.Sc., M.Sc.

Thesis submitted to  
The Department of Human Biology and Health  
University of Surrey,  
in partial fulfillment of the requirements for the  
Degree of Doctor of Philosophy

January 1979

ProQuest Number: 10797621

All rights reserved

INFORMATION TO ALL USERS

The quality of this reproduction is dependent upon the quality of the copy submitted.

In the unlikely event that the author did not send a complete manuscript and there are missing pages, these will be noted. Also, if material had to be removed, a note will indicate the deletion.



ProQuest 10797621

Published by ProQuest LLC (2018). Copyright of the Dissertation is held by the Author.

All rights reserved.

This work is protected against unauthorized copying under Title 17, United States Code  
Microform Edition © ProQuest LLC.

ProQuest LLC.  
789 East Eisenhower Parkway  
P.O. Box 1346  
Ann Arbor, MI 48106 – 1346

To

My parents, their grandchildren and my wife

ACKNOWLEDGEMENTS

I am indebted to Professor P.R. Davis for providing facilities and support for me to carry out this work.

My most sincere thanks are due to Dr. R.J. Howland, who undertook the task of supervising this work, for his unfailing guidance and friendship.

Thanks are due to, Mr. B. Naish and the workshop staff for their advice and assistance in the construction of the perfusion assembly, Mr. P. Scobie-Trumper and the animal house staff for maintenance of the experimental animals, Miss V. Ronaasen for her technical assistance in gas analysis and animal surgery, Pharmacia Diagnostics for their generous aid in the provision of material for the insulin radioimmunoassay, Dr. S. Santana de Sa for her helpful criticisms of the draft of this thesis and Mrs. M. Ellis for typing it.

I am grateful to my brother Elie (Abu-Mitri) for his financial support.

SUMMARY

This investigation was based on the hypothesis that long term cold exposure (cold-acclimation) reduces the overall amounts of insulin secreted by the pancreatic islets of Langerhans of the rat and possibly also reduces insulin synthesis. Evidence was obtained indicating that this effect was mediated through the sympathetic postganglionic terminals at the pancreatic beta-cells. The study was made on isolated perfused pancreases in a purpose-built perfusion system, and an artificial perfusion medium with a fluorocarbon as oxygen carrier were used.

It was confirmed that insulin secretion from the isolated perfused pancreas, in response to glucose stimulation follows a biphasic secretion pattern. Cold-acclimation reduces insulin secretion as a result of alpha-adrenergic activity. This effect was reversed by the action of the alpha-adrenergic antagonist phentolamine. A similar inhibitory effect on insulin release was achieved by perfusion with noradrenaline (40 ng/100 ml), although not to the same extent of inhibition which prevailed during cold-acclimation. The results suggested that the demonstrated alpha-adrenergic inhibition is directly effected by the pancreatic sympathetic fibres rather than by adrenal medullary secretion of catecholamines. Insulin output was measured by radioimmunoassay and the results were statistically analysed and discussed. It was concluded that during cold-acclimation, inhibition of insulin secretion and enhancement of catecholamine secretion enabled the cold-acclimated rat to maintain an adequate supply of thermogenic substrates for peripheral metabolism.

CONTENTS

	<u>page</u>
ACKNOWLEDGEMENTS	1
SUMMARY	2
CONTENTS	3
LIST OF TABLES	6
LIST OF FIGURES	7
INTRODUCTION	9
I.    Preamble	9
II.   Insulin secretion and glucose	10
III.  Cold-acclimation	14
IV.   Catecholamines, the nervous system and insulin release	18
V.    Insulin release rhythms	26
VI.   Perfusion techniques for the study of insulin secretion	27
VII.  Fluorocarbons as oxygen carriers	30
VIII. The oxygenator	31
IX.   Assay of insulin	32
MATERIALS AND METHODS	34
I.    Experimental animals	34
1.  The normal rats	34
2.  The cold-acclimated rats	35
II.   The pancreas perfusion apparatus	37
1.  General principles of isolated organ perfusion	37
2.  Construction	38
3.  Operation of apparatus during perfusion	45
4.  Cleaning the perfusion apparatus	48
III.  Perfusion media	49
IV.   Preparation and isolation of the pancreas for perfusion	53

	<u>page</u>
ACQUISITION AND PROCESSING OF DATA	58
I.    Glucose analysis	58
II.   Insulin assay	59
III.  Evaluation of oxygen uptake	61
IV.   Volume of flow of perfusates	62
V.    Calculations and statistical analyses	63
1.    Glucose concentration	63
2.    Insulin secretion rate	63
3.    The Student-t-test	64
RESULTS	66
I.    Insulin assay standard curve	66
II.   Oxygen uptake	68
III.  Insulin secretion in the main control group	68
IV.   Insulin secretion in cold-acclimated animals	73
V.    Noradrenaline dose-response effect on insulin secretion	76
VI.   Insulin secretion after cold-acclimation and in the presence of noradrenaline and phentolamine in the perfusates	80
VII.  Insulin secretion after phentolamine treatment during the last week of cold- acclimation of rats	84
VIII. Insulin secretion after bilateral adrenal demedullation of rats at the beginning of the last week of cold-acclimation	87
IX.   Summary of statistical analyses of the results	90
DISCUSSION	94
I.    General observations	94
II.   Discussion of the general observations	95
III.  1.    The secretory dynamics of insulin	95
2.    Effect of cold-acclimation on insulin secretion	100
3.    Effect of noradrenaline perfusion on insulin secretion	105
4.    Effect of phentolamine treatment during cold-acclimation	109
5.    Alpha-adrenergic regulation of insulin secretion	113

	<u>page</u>
REFERENCES	123
RELEVANT REFERENCES NOT CITED IN THE TEXT	152
APPENDICES	
Appendix 1 : The oxygenator	157
Appendix 2 : The temperature meter unit	158
Appendix 3 : The drop recorder unit	159
Appendix 4 : The oxygen dissociation curve of FX-80.	160



List of Tables

	Page
Table 1. Data obtained from outflow of perfused pancreases of the main control set of rats	69
Table 2. Data obtained from outflow of perfused pancreases of the cold-acclimated set of rats	74
Table 3. Data obtained from outflows of pancreases perfused with different noradrenaline (NA) concentrations	77
Table 4. Data obtained from outflow of pancreases, in the presence of both noradrenaline and phentolamine	82
Table 5. Data obtained from outflow of perfused pancreases of cold-acclimated rats treated with phentolamine during the last week of cold-acclimation	85
Table 6. Data obtained from outflow of perfused pancreases of cold-acclimated rats subjected to bilateral adrenal demedullation performed at the beginning of the last week of cold-acclimation.	88

List of Figures

	Page
Figure 1. The perfusion assembly	39
Figure 1a. Detail of main water bath of Fig. 1.	40
Figure 2. Schematic diagram of perfusion assembly	41
Figure 3 (a) Schematic diagram of the rat dorsal aorta	
(b) Schematic diagram of the isolated perfused unit	55
Figure 4. Insulin standard curves	67
Figure 5. Histogram of insulin secretion rates in the main control group	70
Figure 6. Histogram of insulin secretion rates in the cold-acclimated rat	75
Figure 7. Comparative summary of noradrenaline dose-effect on insulin secretion rates	78
Figure 8. Histogram of insulin secretion rates from pancreases of cold-acclimated rats, perfused in the presence of noradrenaline and phentolamine	83
Figure 9. Histogram of insulin secretion rates of pancreases of rats treated with phentolamine during the last week of cold-acclimation	86

## (List of Figures, continued)

	Page
Figure 10. Histogram of insulin secretion rates of pancreases of rats subjected to bilateral adrenal demedullation during the last week of cold-acclimation	89
Figure 11. Photomicrographs of sections of normal rat adrenal (a) and regenerating demedullated adrenal (b)	92
Figure 12. Comparative summary of basal and glucose stimulated insulin secretion rates of the main control and the experimental sets.	93

## INTRODUCTION

### I. Preamble

This introduction presents and discusses evidence concerning the dynamics of glucose-induced insulin secretion as well as other factors influencing insulin release from the beta-cells of the islets of Langerhans, especially the catecholamines and the autonomic nervous system. Both short- and long-term cold exposures, are unique in their direct and indirect stimulatory effects on metabolism. Cold exposure has been shown to enhance the activity of the sympathetic nervous system and consequently to increase levels of catecholamine secretion.

The objectives of the present investigation are to study the secretory dynamics of the isolated perfused pancreas of the cold-acclimated rat, in relation to catecholamine and glucose sensitivity and to verify the source of the effective catecholamines. Thus, the principal hypothesis put forward will be that long-term cold exposure (cold-acclimation) reduces the overall amounts of insulin released and possibly in addition, reduces the level of insulin synthesis, and that this effect is due to the increased noradrenaline secretion of the adrenergic nerve endings in the vicinity of the beta-cells of the pancreas.

For this investigation a perfusion system was built in order to permit continuous monitoring of relevant physiological parameters. Insulin production was measured by a radio-immunological method.

It is hoped that the results will yield a better understanding of the regulation of thermogenic metabolism in long-term cold.

## II. Insulin secretion and glucose

Increased local glucose concentration is one of the major physiological stimuli for insulin secretion from the pancreatic beta-cells. Many investigators in this field have demonstrated that changes of glucose concentrations, both in vivo and in vitro, induce parallel changes in insulin release from the pancreatic islet tissue (Coore and Randle, 1964b; Grodsky and Bennett, 1963; Malaisse, Malaisse-Lagae, and Wright, 1967a; Mangay, DeRuyter, Tonber, Croughs, Schopman and Lenquin, 1967; Metz, 1960; Sussman, Vaughan and Timmer, 1966). In the isolated perfused pancreas, sudden increases of glucose concentration are followed by an immediate release of insulin (Curry, Bennett and Grodsky, 1968a,b; Grodsky, Batts, Bennett, Vcella, McWilliams and Smith, 1963; Sussman et al., 1966). Detailed analysis of the actions of hypo- and hyper-glycaemia have been performed on the isolated and perfused rat pancreas, after exclusion of all extrapancreatic tissue (stomach, spleen, duodenum and jejunum) by the technique described by Sussman et al. (1966) and Loubatières, Mariani and Chapal (1970 a,b). Such a preparation permitted a conclusive exploration of the dynamics of the secretion of insulin not afforded by other isolated pancreatic tissue preparations such as isolated islets, slices or tissue fragments; with this approach, the following facts have been established:

1. In the absence of glucose in the perfusion medium, the isolated perfused rat pancreas secretes insulin at a basal rate of less than 2 ng/min. The reported work does not clarify the osmolar effects of the absence of glucose.

2. In the presence of increasing concentrations of glucose, the insulin secretion pattern of the pancreas is markedly different.

It was shown that if the isolated and perfused rat pancreas is submitted to continuous perfusion by a physiological medium containing 17 mmol/l glucose, there appears an immediate acute intense phase of insulin secretion lasting approximately five to six minutes. If the perfusion of glucose continues, a second phase of insulin secretion follows, rising to a plateau that is directly related to the concentration of glucose. The relationship established between the concentration of glucose in the medium and the quantity of insulin secreted shows that in response to the change of glucose concentration from 4.44 mmol/l to 16.65 mmol/l, the corresponding change in the secretion rate of insulin is from 4 ng/min. to about 200 ng/min.

3. When glucose is removed from the perfusion medium, the insulin secretion rate falls and rapidly attains the level of basal secretion, even after glucose has been continuously supplied for sixty minutes. This suggests

that glucose or its metabolites have a stimulating effect of very short duration on insulin secretion and that these stimulating substances are probably rapidly destroyed, metabolised or removed.

Thus, it is well established that glucose stimulates insulin release from the pancreas. This raises the important question of whether glucose also stimulates insulin biosynthesis and if so, by what mechanism and whether such a mechanism has any effect on the process of insulin release. Current investigations centre on the hypothesis that some direct or indirect product of glucose metabolism provides the stimulus (Mayhew, Wright and Ashmore, 1969). Indeed, investigators have shown a three to four fold increase in the rate of incorporation of radioactive amino acids into insulin following the perfusion of glucose in the concentration range of 3-28 mmol/l (Clark and Steiner, 1969; Howell and Taylor, 1966; Lin and Haist, 1969; Morris and Korner, 1970; Steiner, Cunningham, Spigelman and Aten, 1967; Tanese, Lazarus, Devrim and Recant, 1970). (The degree of stimulation of radioactive amino acid incorporation into insulin ranged between three- and four-fold in the different experiments). When islets are stimulated maximally by glucose, insulin makes up as much as fifty per cent or more of the total protein synthesized (Steiner et al., 1967). Mannose stimulates insulin

biosynthesis, but less strongly than glucose, whereas fructose, ribose and xylitol have no effect (Lin and Haist, 1969). Mannoheptulose, an inhibitor of glucose phosphorylation and of insulin secretion (Ashcroft and Randle, 1968; Coore and Randle, 1964a), also inhibits insulin biosynthesis (Lin and Haist, 1969). Pyruvate, a readily oxidized substrate, does not stimulate insulin biosynthesis, nor does it overcome the inhibitory effects of mannoheptulose, indicating that increased availability of energy is not the basis of the biosynthetic stimulus of glucose (Lin and Haist, 1969). However, other observations indicate that insulin secretion and synthesis involve oxidative metabolism of glucose and energy production. Glucose-stimulation is blocked by anoxia, potassium cyanide and 2,4-dinitrophenol (Coore and Randle, 1964b; Malaisse, Malaisse-Lagae, and Wright, 1967a), which implicates the necessity of oxidative processes. In view of the metabolic blocking action of 2-deoxyglucose in the utilization of glucose-6-phosphate it is suggested that the glucose-stimulated insulin release occurs after the formation and further metabolism of glucose-6-phosphate (Kilo, Devrim, Baily and Recant, 1967). Whether receptors for glucose or its various metabolites exist to account for the stimulus to both biosynthesis and secretion of insulin remains to be determined.



Various lipid metabolites are claimed to stimulate insulin secretion. However, in many cases their insulintropic effect is relatively modest and is only apparent under favourable experimental conditions. Short-chain fatty acids (octanoate, valerate, butyrate, propionate, but not acetate) exhibit a mild stimulatory effect on insulin release in rat, rabbit and pig (Horino, Machlin, Hertelendry & Kipnis, 1968; Malaisse and Malaisse-Lagae, 1968). Thus, these acids have been shown to enhance glucose-induced insulin secretion from pancreatic tissue or isolated islets from fetal and adult rats in vitro (Gagliardino and Martin, 1966; Montague and Taylor, 1968). Whether lipid metabolites play a significant role in the regulation of insulin secretion under physiological conditions remains to be ascertained. Nevertheless, it has been proposed that their stimulation of insulin secretion could function during starvation in the control and maintenance of a low but vital concentration of plasma insulin which is necessary to prevent the development of fatal ketoacidosis (Madison, Mebane, Unger and Lockner, 1964; Seyffert and Madison, 1967). A similar vital role could prevail during cold exposure which shows a marked mobilization of lipid metabolites.

### III. Cold-acclimation

Energy metabolism and associated phenomena during exposure to cold have been the subject of considerable research. Short term exposure to cold results in an immediate and apparent shivering thermogenesis, while long term exposure culminates in an altered steady state of non-shivering thermogenesis affected by corresponding physiological changes. The term "cold-acclimation" is restricted

to designate the effects of prolonged exposure to chronic cold, where this is the only factor being changed, whereas "cold-acclimatization" is used to describe seasonal changes in which multiple environmental effects are involved, i.e. where temperature is not the only variable factor (Hart, 1960, 1962).

The development of cold-acclimation requires a period of time usually estimated to be from two to six weeks by many observers (Chin & Cheng, 1976; Chowder, Siegel, Conforti & Baranes, 1977; Depocas, 1959a, 1959b, 1960b; Guernsey and Stevens, 1977; Himms-Hagen, 1972; Jansky, 1973; Kennedy, Hammond and Hamolsky, 1977; LeBlanc and Nadeau, 1961; Maekubo, Moriya and Hiroshige, 1977; Smith, 1962). During this time there is a gradual increase in cold resistance together with an increase in food consumption and an elevation of basal metabolic rate (Baker and Sellers, 1953). Peripheral and sometimes central temperature are also elevated and there is a decrease in shivering and an increase in non-shivering heat production with the associated physiological and biochemical changes (Foster, Frydman and Usher, 1977; Hart, 1960; Smith, 1962).

Depocas (1959a, 1962) and Depocas and Masironi (1960) reported a constant finding that the cold-acclimated rats had a higher concentration of plasma glucose, and a larger pool size of glucose than the normal or warm-acclimated rats. They also reported an increase in turnover rate of body glucose when liver glycogen reserves are depleted which implies that exposure to cold results in effective stimulation of gluconeogenesis.

This evidence militates against a preferential oxidation of fatty acids in the metabolic response to cold (suggested earlier by Kayser, 1937; and Page and Chenier, 1953).

In a more recent study, Himms-Hagen (1972) demonstrated that the white adipose tissue serves as a store of readily mobilized free fatty acid substrates for thermogenesis in other tissues during cold-acclimation. It has been shown that brown adipose tissue which is markedly hypertrophied during this period is the site for this thermogenic process (Dawkins and Hull, 1964; Hardman and Hull, 1970; Horwitz, 1971; Hull and Segal, 1965; Smith, 1962; Smith and Horwitz, 1969). Furthermore, Beck, Zaharko and Kalser (1967) reported that rats exposed for two to seven weeks to severe cold ( $5 \pm 2^{\circ}\text{C}$ ) exhibited, in comparison with control rats, significant decreases in serum glucose. Similarly, Himms-Hagen (1972) reported that the principal, but not the only substrate utilized during cold exposure and cold-acclimation is lipid. The concentration of free fatty acid in the blood was observed to be higher than normal suggesting increased lipolysis and free fatty acid release. The cellular oxidation of plasma free fatty acid is increased as is their turnover rate and the store of triglycerides in the white adipose tissue decreases (Masironi and Depocas, 1961).

As mentioned earlier, the cold-acclimated animal undergoes various adaptive adjustments during this acclimation period in which the replacement of shivering thermogenesis by non-shivering thermogenesis occurs. There is considerable evidence that the

adaptation to non-shivering thermogenesis is associated with a very marked enhancement of the thermogenic response to noradrenaline and adrenaline (Depocas & Secours, 1960; Hannon, 1963; Himms-Hagen, 1972; Hsieh and Carlson, 1957; Jansky, 1973). Euler (1971) reported that during exposure to cold, a clear reaction of the animal is in many cases a greatly increased concentration of noradrenaline in both blood and urine. Similarly, Nathanielsz (1969) observed that cold exposure is a very potent stimulus to the sympathetic nervous system for there is an increase in catecholamine synthesis and secretion which is mainly in the noradrenaline fraction. Thus, it is possible that the changes induced by cold are attributed to reduced availability of insulin in the white adipose tissue, to both reduced availability of insulin and increased availability of noradrenaline in the heart and to increased release of noradrenaline in brown adipose tissue (Himms-Hagen, 1972). Baker and Ashworth (1958) showed that the amount of insulin extractable from the pancreas of rats was decreased by exposure to cold ( $1.5^{\circ}\text{C}$ ) for a period of fifty days, at the same time there was an increased sensitivity to insulin after cold-acclimation which might have been the result of a decreased availability following a reduced requirement for insulin. Perhaps the prolongation of this reduced requirement then resulted in the reduction of the insulin content of the pancreas. Beck et al. (1967), Howland (1967) and Howland and Nowell (1968) demonstrated that rats exposed for two to seven weeks to severe cold exhibited, in comparison with controls, significant decreases in serum glucose and immunoassay insulin levels.

#### IV. Catecholamines, the nervous system and insulin release

A remarkably wide variety of compounds can influence the secretion of insulin in intact animals. Compounds which stimulate its secretion include glucose (Ashcroft and Randle, 1968 a,b; Depocas, 1959 a,b; Grodsky, Curry, Bennett and Rodrigo, 1968; Kilo, Long, Bailey, Koch and Recant, 1962; Lerner, 1977; Nowell and Howland, 1966; Snyder, Kashket and O'Sullivan, 1970), free fatty acids (Horwitz, 1971; Seyfert and Madison, 1967), Ketone bodies (Balasse, Couturier and Frenckson, 1967; Goberna, Tamarit, Osorio, Fussganger, Tamarit & Pfeiffer, 1974; Madison et al., 1964; Malaisse and Malaisse-Lagae, 1968; Pi-Sunyer, Campbell and Hashim, 1970), amino acids (Basake, Lopez, Viktora and Wolff, 1971; Floyd, Fajans, Conn, Knopf and Rull, 1966; Floyd, Fajans, Pek, Thiffault, Knopf and Conn, 1970), intestinal hormones such as pancreozymin (Mahler and Weisberg, 1968), secretin (Deckert, 1968) and gastrin (Dupre, Curtis, Unger, Waddell, and Beck, 1969; Unger, Ketterer, Dupre and Eisentraut, 1967), and other hormones such as glucagon (Campbell and Rastogi, 1966; Deckert, 1968; Devrin and Recant, 1966; Karam, Grasso, Wegienka, Grodsky and Forsham, 1966; Ketterer, Eisentraut and Unger, 1967; Porte, 1967 b; Samols, Marri and Marks 1965, 1966), and adrenocorticotrophic hormone (ACTH) (Sussman and Vaughan, 1967). That parasympathetic stimulation also increases insulin secretion is indicated by the atropine-sensitive stimulatory effect of administered parasympathomimetic compounds in vivo (Kajinuma, Kaneto, Kuzuya and Nakao, 1968) and in vitro (Malaisse, Malaisse-Lagae, Wright and Ashmore, 1967 b) and by the increase in insulin secretion produced by vagal stimulation both in vitro and in vivo (Bergman and Miller, 1973; Daniel and

Henderson, 1967; Frohman, Ezdinli and Javid, 1966, 1967; Kaneto, Kosaka and Nakao, 1967; Kaneto, Kajinuma, Kosaka and Nakao, 1968). The sensitivity of the insulinogenic response to these different stimuli varies according to the species, which might be a purely anatomical effect involving nerve terminals distribution.

Any effective regulatory influence of endogenous catecholamines must be considered against this background of multiplicity of stimuli to insulin secretion. Activation of the sympathetic nervous system would be expected not only to produce an inhibition of insulin secretion but also to produce an increase in the concentrations in blood of several metabolites such as glucose, free fatty acids and ketone bodies, which may stimulate insulin secretion. The physiological function of this inhibition of insulin secretion becomes apparent when considered as prevention of the enhancement of insulin secretion that would normally occur in response to raised concentrations of these metabolites. This inhibition by the catecholamines allows the pancreas to respond to the increased concentrations of those metabolites in the blood due to an ingestion of a meal in a different way from that when it responds to the increased concentrations of the metabolites in the blood due to the sympathetic-mediated stress reactions

In order to discuss the possibility of a role for sympathetic tone in the basal regulation of insulin secretion, evidence for which comes mainly from the use of blocking agents, it is necessary first to consider briefly the effects of blocking agents on the

secretion of insulin in the intact animal. Infusion of adrenaline or noradrenaline inhibits the rise in plasma insulin that would otherwise occur in response to hyperglycaemia, produced either by the catecholamines themselves or by administration of glucose (Campbell and Rastogi, 1966; Hertelendy, Machlin, Gordon, Horino and Kipnis, 1966; Karam et al., 1966; Kris, Miller, Wherry and Mason, 1966; Porte, Graber, Kuzuya and Williams, 1966; Porte and Robertson, 1973; Porte and Williams, 1966; Potter, Wilson and Ellis, 1977). Alpha-adrenergic blockade with phentolamine prevents the inhibition and permits a rise in plasma insulin concentration (Kansal and Buse, 1967; Porte, 1967 a); whereas Beta-adrenergic blockade (with propranolol) potentiates the inhibition (Porte, 1967 b). The reported result that alpha-adrenergic agonists inhibit insulin release was made by many investigators (Buse, Allan, Kuperminc and Buse, 1970; Cerasi, Effendic and Luft, 1969; Malaisse et al., 1967 b; Yajima, Hosokawa and Ui, 1977).

Attempts to assess the extent to which catecholamines exert a tonic inhibitory effect on insulin secretion under basal conditions have employed the alpha-receptor blocking agent phentolamine. Phentolamine does raise plasma insulin concentration (Bressler, Gordon and Bredel, 1969; Frohman et al., 1967; Werrback, Gale, Goodner and Conway, 1970), and potentiates the rise in insulin concentration produced by glucose (Buse et al., 1970; Cerasi et al., 1969) or by theophylline (Turtle and Kipnis, 1967 b). This can be interpreted as evidence for a continuous basal inhibition of

insulin secretion by the catecholamines. However, it should be remembered that phentolamine also has other effects in intact animals. It raises plasma free fatty acids concentration (Boshart, Will, Pirre and Ringler, 1965) and raises plasma lactate concentration by producing activation of muscle glycogenolysis (Salvador, April and Lemberger, 1968); both effects apparently due to increased catecholamine secretion, principally from the adrenal medulla (Boshart et al., 1965; Salvador et al., 1968). Phentolamine also raises plasma corticosterone concentration in rats (Govier, Lovenberg and Sjoerdsma, 1969). Thus, phentolamine may not only prevent endogenous catecholamines inhibiting secretion of insulin, but may at the same time cause the appearance in the blood of free fatty acids which can stimulate insulin secretion. That a hypoglycemia results (Salvador et al., 1968) is probably due to the increased secretion of insulin. However, it is not clear to what extent the increased insulin secretion can really be attributed to reduction of sympathetic tone and to what extent it is due to stimulation of insulin secretion by the raised free fatty acids concentration. Unfortunately, the use of beta-receptor blocking agents to prevent the rise in plasma free fatty acids concentration would not be helpful in resolving this question because these agents also block the rise in insulin secretion produced by a variety of other stimuli, including the administration of phentolamine (Bressler et al., 1969).



A great deal of evidence has now accumulated supporting the hypothesis that both the sympathetic and the parasympathetic nervous systems share the capacity to make 'time adjustments' to insulin secretion rates. The islets of Langerhans are provided with a rich sympathetic and parasympathetic innervation (Woods and Porte, 1974). Frohman et al. (1966,1967) have shown that stimulation of the vagus nerve in anaesthetized dogs is followed by an increase in serum immunoreactive insulin. Vagotomy alone is accompanied by a decrease in insulin level and no change in blood glucose. Stimulation of the distal end of the sectioned vagus nerve leads to a prompt rise in portal insulin and a small rise somewhat later in peripheral plasma insulin; the rise in insulin was blocked by atropine. Such studies of vagal stimulation and vagotomy, indirectly indicate that cholinergic innervation of the islets may regulate insulin release (Chowers, Lavy and Harpen, 1966; Daniel and Henderson, 1967; Kaneto et al., 1967; Loubatières-Mariani, Chapal, Alric and Loubatières, 1973; Miller and Whittenberger, 1968; Nelson, Blachard, Cocchiara and Labat, 1967).

On the other hand, the demonstration that both adrenaline (Loubatières et al. 1970 a; Porte et al., 1966) and noradrenaline (Porte and Williams , 1966) inhibit the release of insulin from the beta-cell which is induced by glucose, glucagon and tolbutamide is clearly relevant since noradrenaline is the neurochemical transmitter secreted at sympathetic nerve endings which are known to be plentiful in the islets of Langerhans and possibly to

25

terminate at the beta-cells (Lacy, 1967; Woods and Porte, 1974). Simultaneous intravenous infusion of a glucose load with noradrenaline resulted in a lower immunoreactive insulin concentration than expected during the infusion of noradrenaline, but returned to normal (or higher) values after the noradrenaline infusion was stopped (Porte and Williams, 1966).

Stimulation of the splanchnic nerve inhibits glucose-induced insulin release (Bloom, Edwards and Vaughan, 1973; Kaneto, Kajinuma, Hayashi and Kosaka, 1974). Although little is known of the local concentration of noradrenaline at sympathetic effector sites after stimulation of sympathetic nerves, conceivably these concentrations are similar to the concentration of noradrenaline in the plasma (Porte and Williams, 1966). Euler (1971) reported that noradrenaline released from sympathetic nerve terminals is known to appear in the blood. Thus, the level of noradrenaline in the blood could therefore serve as an indicator of the rate of transmitter release (Benedict, Fillenz, Stanford and Valero, 1977).

These observations support the hypothesis that the sympathetic nervous system plays a tonic role (through the action of noradrenaline) in the regulation of insulin release.

That this noradrenaline is from extra-adrenal origin is shown in adrenalectomized rats which excreted as much noradrenaline as intact animals on exposure to cold (Leduc, 1961 a,b; LeBlanc and Nadeau, 1960) or more than the controls (Johnson, Schönbaum & Sellers, 1966). Moore, Calvert & Brody (1961) reported that after cold-acclimation the increased content of catecholamines in the adrenal medulla is not necessarily accompanied by increased secretion of

these amines. Furthermore, as far as the studies performed on adrenalectomized human patients are concerned (Sacca, Perez, Carteni and Rengo, 1977), it is important to mention that the removal of the adrenal glands does not assure the elimination of all catecholamine-producing chromaffin tissue deposits. An increase in the urinary content of adrenaline has been observed in many species after adrenal medullectomy in response to various stimuli including insulin-induced hypoglycemia (Armin and Grant, 1959; DeBodo and Altszuler, 1958; Vendsalu, 1960), and cold exposure (Leduc, 1961 a,b). In all these conditions it must be assumed that catecholamines are derived from extra adrenal sources which seem able to respond to the various stimuli. Although the role of noradrenaline in the homeostatic response to insulin-induced hypoglycemia is not fully understood, the aforementioned studies strongly suggest the possibility that an excess of noradrenaline in demedullated animals, particularly that released from post-ganglionic neurons at the intra hepatic and intra pancreatic levels may be of great importance in facilitating the re-establishment of metabolic equilibrium following insulin hypoglycemia (Sacca et al., 1977). These studies performed on adrenodemedullated rats provide evidence that the integrity of the sympathetic nervous system is essential for an efficient homeostatic response in situations such as insulin-induced hypoglycemia or cold-exposure.

Catecholamines are thought to have a direct effect on the secretion of insulin through their influence on the activity of the beta-cell adenylyclase (Cyclic AMP) system. It has been accepted

that beta-adrenergic stimulation of the beta-cell enhances insulin secretion by activation of this system, raising the cyclic AMP concentration within the cell and that alpha-adrenergic stimulation inhibits insulin secretion by antagonizing this rise of the cyclic AMP (Porte and Robertson, 1973). Adrenaline, in the presence of theophylline, prevented the accumulation of cyclic AMP, but when an alpha-adrenergic blocker (Phentolamine) was added, normal accumulation of the nucleotide occurred; beta-adrenergic blockade did not antagonise the action of adrenaline (Turtle and Kipnis, 1967 a). This suggests that production of cyclic AMP is reduced to a low level when an alpha-adrenergic stimulation is applied. Comparing these observations with the parallel effects upon insulin secretion suggests that the cyclic AMP level in beta-cells can modify the rate of insulin release.

That cyclic AMP has effects on ion flux, which in turn affect insulin release, may be considered as another site of action of the catecholamines on insulin secretion (Hales, 1970; Rasmussen and Tenenhouse, 1968), whereby, it is suggested that the effects of cyclic AMP may be mediated by an effect of the nucleotide to increase the concentration of ionized calcium in cytoplasm; whatever their primary site of action, the inhibitory effect of catecholamines is apparently mediated ultimately through a decreased uptake of calcium ions by the beta-cells (Case and Clausen, 1973; Malaisse, Brisson, Malaisse-Lagae, 1970; Malaisse, Malaisse-Lagae, 1970). Finally, the addition of adrenaline to an incubation medium and the omission of calcium ions (Grotsky & Bennett, 1966) from

the medium are the only two experimental conditions known to suppress, in vitro, the insulintropic effect of all agents so far investigated.

V. Insulin release rhythms

Plasma insulin levels in mammals are the end result of the effects of different mechanisms. Though plasma glucose levels play an important direct role, hormones and other factors also influence the pancreatic secretion of insulin. Considering the existence, in the rat, of a diurnal rhythm which might affect insulin secretion (Allen and Kendall, 1967), Jolin and Montes (1973) demonstrated that plasma insulin levels show higher values during daytime with a maximum at 1700 h. These spontaneous oscillations of plasma insulin levels are not merely a consequence of those of the glucose level. Circadian periodicity of ACTH (Clayton, Librik, Gardener & Guillmen, 1963), and glucocorticoids (Allen & Kendall, 1967) secretion levels have been reported in rats and these hormonal fluctuations could well affect the pancreatic secretion of insulin thereby modifying the levels of glucose and insulin in plasma. It is noteworthy to mention that the noradrenaline levels did not show any significant daily variations (Benedict et al., 1977 b). Thus, measurements of plasma insulin and glucose levels may give misleading results if control and experimental groups of animals are not examined at the same time of the day.

21

On the other hand, Howland and Nowell (1968) demonstrated seasonal changes of plasma insulin concentration in the rat; whereby, maximum concentrations were recorded in June and minimum concentrations in November. When the increase of plasma insulin following a glucose load was expressed as a percentage of the fasting plasma insulin concentration, it was found that the response to glucose loading, in terms of insulin secretion, was greater during the winter than the summer months. The rat, maintained in artificial cold however, displayed a very low response in January, concomitant with a high insulin sensitivity recorded at this time. The decrease of plasma insulin content, seasonally and in response to a low environmental temperature, is thought to be related to a proposed endogenous cycle of islet beta-cells activity and the winter-enhanced secretory capacity of the beta-cells was related to the increased turnover of glucose in the cold-exposed animal (Howland, 1967).

VI. Perfusion techniques for the study of insulin secretion

Insulin secretion has been examined both in vivo and in vitro. Of the two basic procedures carried out in vitro, the first, introduced by Anderson and Long (1947), involves perfusion of the rat's isolated pancreas with diluted blood or synthetic medium; whereas the second, involves media of known composition in which pieces of pancreatic tissue, isolated islets or explants of cultured pancreatic tissue are incubated (Coore and Randle, 1964 b;

Hellerstrom, 1964; Malaisse et al., 1967-a; Malaisse, Malaisse-Lagae and Mayhew, 1967 c; Malaisse, Malaisse-Lagae, Lacy and Wright, 1967 d).

Two groups of investigators are mainly credited for recent work obtained with the perfused pancreas. Sussman et al. (1966) used pancreatic tissue completely separated from surrounding organs while Grodsky et al. (1963) and Loubatières, Mariani, Chapal and Portal (1967) left the stomach, spleen, and duodenum attached. Diluted blood or bicarbonate buffered medium was infused through the aorta or coeliac axis, and effluents were collected from the hepatic portal vein. These media were either recycled or allowed to collect after a single passage, substances under study being incorporated in recycled media or injected as a "pulse" for a single passage through the tissue. Insulin output from the perfused pancreas was represented either in absolute units or in terms of its concentration in the effluent medium.

Although perfusates made up of whole or diluted blood have been considered to be optimally physiological, certain changes that occur in blood in a perfusion circuit result in a few disadvantages such as:

1. plasma lipoproteins might be denatured at the fluid/air and fluid/glass interfaces. This results in the formation of fat emboli which increase vascular resistance (Belzer et al., 1968).

2. glass and rubber surfaces stimulate platelet aggregation.
3. the essential addition of anti-coagulants to blood, such as heparin, have some metabolic effects. Citrates and other chelating agents reduce the availability of certain important ions such as calcium and magnesium.
4. haemolysis of red blood cells usually occurs in the perfusion apparatus and this is known to cause insulin destruction (Grodsky et al., 1963).

Nevertheless, blood contains all essential factors for proper organ function, and most of the listed disadvantages are being minimized by the use of better oxygenators, connecting tubing, and more suitable vasodilators.

In synthetic perfusion media the maintenance of colloid osmotic pressure is accomplished by the use of plasma substitutes or expanders such as albumin, gelatine or dextran which was used by Grodsky et al., (1963) for pancreas perfusion experiments. The simple exposition of Starling's law is that blood circulating through a capillary bed loses fluid to the interstitial space when the hydrostatic pressure within the capillary exceeds the sum of the external tissue pressure and the colloid osmotic pressure within the lumen of the vessel. Since the hydrostatic pressure drops between the arterial and venous ends of the capillary, fluid



is lost at the former end and then regained at the latter end of the capillary. In perfusion experiments, the artificial medium and perfusion pressure, as well as the venous pressure should be selected to achieve a similar balance, so that net fluid loss from the vascular compartment does not occur.

#### VII. Fluorocarbons as oxygen carriers

It would seem preferable to produce a standardized synthetic medium, which does not contain blood, that could be used in organ perfusion.

Recently, oxygen-carrying fluorocarbon suspensions have become available for use to overcome most problems associated with the fragile red blood cell (Gollan and Clark, 1966; Sloviter and Kamimoto, 1967).

Fluorocarbons are generally regarded as biologically inert compounds (Clark and Gollan, 1966). They have high diffusion coefficients for gases. A liquid fluorocarbon "FX-80", composed predominantly of perfluorobutyl-tetrahydrofuran and its isomers (3M Co.), has a relatively high solubility for oxygen and carbon-dioxide and when saturated with oxygen, it contains 0.63 ml of the dissolved gas per ml suspension (Sloviter and Kamimoto, 1967). These workers also demonstrated that "FX-80" in a dispersed colloidal suspension (by sonication) adequately carries out the essential functions of the erythrocyte in perfusing the rat brain, and recommended it for perfusion studies of other organs.

Geyer, Monroe and Taylor (1968) reported that certain fluorocarbons in a protein-free mixture can be formulated to function well in place of blood in the living intact rat on a short term basis and concluded that fluorocarbons and high-molecular weight micellar substances hold promise for perfusion used both in vivo and in vitro. On the other hand, Gollan, McDermott, Duggen and Musil (1972) reported that fluorocarbon emulsions proved to be inefficient in delivering oxygen to the tissues of intact animals. The reason for this is probably due to the presence of protein molecules in concentrations as low as 2 µg/100 ml, which change interfacial tension at water-fluorocarbon interfaces (Rosenberg, 1971). In isolated organs the blood is usually washed out initially with a large volume of perfusate, and the content of protein to be selectively absorbed on the fluorocarbon microparticles is probably too low to interfere with the delivery of a large volume of dissolved oxygen to a small mass of tissue (Gollan et al., 1972). Nevertheless, as other similar compounds become available, still better preparations for such uses might be possible.

#### VIII. The oxygenator

An efficient reliable oxygenator is an essential requirement of an organ perfusion apparatus. The perfusion medium reaching the organ should contain enough oxygen to fully supply the need of the tissue under investigation.

There are various types of oxygenator which vary as to their efficiency, adequacy and ease of use. These oxygenators used in perfusion of a wide range of organs have been fully described and reviewed by Norman (1968) and Ross (1972), including: (i) bubblers, (ii) falling columns, (iii) films, (iv) rotating chambers, (v) rotating discs or cylinders, (vi) membrane oxygenators.

The rotating cylinder oxygenator or screen oxygenator is generally used for small organ perfusions where haemoglobin-free media are used. A plastic-coated mesh cylinder revolves about its long axis within the chamber, carrying a film of the medium up into the gas filled compartment above. Excessive gas loss usually takes place in this oxygenator and the inflow oxygen tension may not be the same as that of the medium leaving it. Cleaning is difficult. This oxygenator has been successfully used in perfusion of the pancreas as employed by many investigators.

#### IX. Assay of insulin

Initial attempts to assay insulin were based upon the biological activity of the hormone, a method which proved to be lacking in sensitivity. Yalow and Berson (1960) developed the radioimmunoassay procedure and a sensitive assay technique was found in the various modifications thereafter.

As summarized by Mayhew et al. (1969), a constant amount of anti-insulin serum is allowed to react with an excess of insulin, a constant trace amount of which is radioactively labelled with

$^{131}\text{I}$  or  $^{125}\text{I}$ . At the end of the period of incubation two forms of insulin can be discerned: part of the hormone is bound by antibodies in the anti-insulin serum, and the excess remains free in solution; the two forms are termed "bound" and "free" insulin. Several techniques have been used to separate and measure the amounts of bound and free insulin in all such incubated mixtures (Beck, Zaharko, Roberts, McNeil, King, and Blankenbaker, 1964; Grodsky and Forsham, 1960; Hales and Randle, 1963; Herbert, Lau, Bottleib & Bleicher, 1965; Karam, Grodsky & Forsham, 1963; Mitchell and Byron, 1967; Morgan and Lazarow, 1963; Wright, Makulu, Malaisse, Roberts & Yu, 1968; Zaharko and Beck, 1968).

From the relative amounts of radioactivity associated with the free and bound fractions of insulin obtained with samples and with standard solutions of insulin, the insulin contents of the samples can be determined. Meaningful results should take into consideration species differences concerning anti-insulin sera, standard insulin references and unknown insulin samples.

## MATERIALS AND METHODS

### I. Experimental animals

Wistar albino rats (Rattus norvegicus) were used, because most reported works on cold-acclimation and isolated pancreas perfusion experiments were done on them, as well as the ease of obtaining and maintaining these animals. The rats were all males because they keep a less variable endocrine physiology than females. The average age of the rats was three months at the time they were sacrificed and they weighed between two and three hundred grams. They were separated into two main categories:

1. The normal rats.
2. The cold-acclimated rats (which had been continuously exposed to a low temperature ( $4^{\circ}\text{C}$ ) for a period of six weeks and thus had been fully acclimated to cold (Chin and Cheng, 1976; Chowers et al., 1977; Depocas, 1959 a,b; Guernsey and Stevens, 1977; Himms-Hagen, 1972; Jansky, 1973; Kennedy et al., 1977; Maekubo et al., 1977; Smith, 1962).

#### 1. The normal rats

Forty two rats with average body weight of 245 g were kept two in a cage (20 cm x 30 cm x 50 cm) in the animal house, at room temperature  $22^{\circ}\text{C}$ , with a constant twelve hour photoperiod from 0800 hours G.M.T. to 2000 hours G.M.T.; they were given food (Spratt's Small Animals Diet No. 1) and water ad libitum. They were fasted for twenty

hours before experiment. Twelve of these rats were used to study the effect of glucose stimulation on insulin release from the isolated-perfused pancreas. This comprised the Main Control Set.

Thirty rats were used to establish a noradrenaline dose-response effect on insulin release by glucose stimulation from the isolated-perfused pancreas. The different noradrenaline doses were included in the perfusion media accordingly, and for each dose six experimental perfusion replicates were done. These comprised the noradrenaline control set.

## 2. The cold-acclimated rats

The cold-acclimated rats were used in four different experimental sets as follows:

- i. Six rats with average body weight  $296.25 \pm 1.54g$ , were put three in a cage (30 cm x 40 cm x 70 cm) and kept, in a constant temperature-room at  $4^{\circ}C \pm 2^{\circ}$  with the same photoperiod as the normal rats, for a period of six weeks. They were given food and water ad libitum, and were fasted for twenty hours before the experiment. This set of rats was used to study the effect of glucose stimulation on insulin release from the isolated-perfused pancreas after cold-acclimation.
- ii. Six rats with average body weight  $208.83 \pm 2.09 g$ , were acclimated to the cold, as previously described,

and were used to study the effect of glucose stimulation on insulin release from the isolated-perfused pancreas in the presence of both nor-adrenaline and phentolamine.

iii. Six rats with average body weight  $208.00 \pm 1.63$  g, were acclimated to the cold, the same as the previous sets except that on the fifth week of acclimation they were given subcutaneous injections of phentolamine ( $25 \mu\text{g}$  in  $0.25$  ml normal saline - Malaisse *et al.*, 1967 b), twice per twenty four hours at 0900 hours and 2100 hours G.M.T., for a period of seven days. They were given food and water ad libitum and were fasted for twenty hours before experiment to investigate the effect of glucose stimulation on insulin release from the isolated-perfused pancreas after phentolamine treatment.

iv. Six rats with average body weight  $205.08 \pm 1.48$  g, were acclimated to the cold, as previously described, but on the fifth week of cold-acclimation they underwent bilateral adrenal-demedullation, after which they were put back in the cold room to complete the six weeks period. They were given food and water ad libitum and a normal saline solution for drinking after the operation. They were fasted for twenty hours before experiment which studied the effect of glucose stimulation on insulin release from the isolated-perfusion pancreas after a week of adrenal-demedullation.

## II. The pancreas perfusion apparatus

### 1. General principles of isolated organ perfusion:

The successful development of techniques for isolated organ perfusion is based on the realisation that the maintenance of organ viability is essential both in the period between cessation of blood flow through the organ, and replacement of blood with an appropriate perfusion medium, and also during the perfusion process, where every effort must be made to maintain the organ under physiological conditions.

Considerations in the design of a perfusion system should come as close as possible to meet the following criteria:

- i. The experimenter must have control over the perfusion medium flow and perfusion pressure.
- ii. The concentration of the stimulatory substances in the perfusing medium must be under experimental control.
- iii. The composition of the perfusing medium, apart from the experimentally varied concentrations of stimulatory substances should be kept constant.

On those grounds, it is concluded that the only certain methods of maintaining control over perfusate composition would be to prepare a large volume of perfusate and pump it through the test organ in a single pass making additions of metabolites or drugs as demanded by the experimental schedule.



The advantages of the perfused pancreas preparations over other techniques used in vitro, such as isolated islets, slices or tissue fragments, are summarized by Loubatières, Mariani, Chapal and Portal (1967) as follows:

- i. Superficial and deep islets are equally provided with oxygen and nutrients, which are constantly replaced. Substrates and effectors arrive at the cell in the same physiologically normal way.
- ii. The islets remain in normal anatomical relationship with other cells and tissues of the organ, including blood vessels and intrinsic nerves.
- iii. The maintenance of the cellular integrity of the tissues can be confirmed at the end of an experiment by microscopic study.
- iv. There is the possibility of a control and an experimental period of study in the same pancreas.

2. Construction:

The pancreas perfusion apparatus is shown in Fig. (1), and its diagrammatic representation is in Fig. (2):

The main water bath (1) was made of perspex boards, one centimeter thick, and dimensions 25 cm x 25 cm x 40 cm. It was heated by the electric heating unit (2)

Figure 1. The perfusion assembly. (For further details of the main water bath and contents see Fig.1a, overleaf).

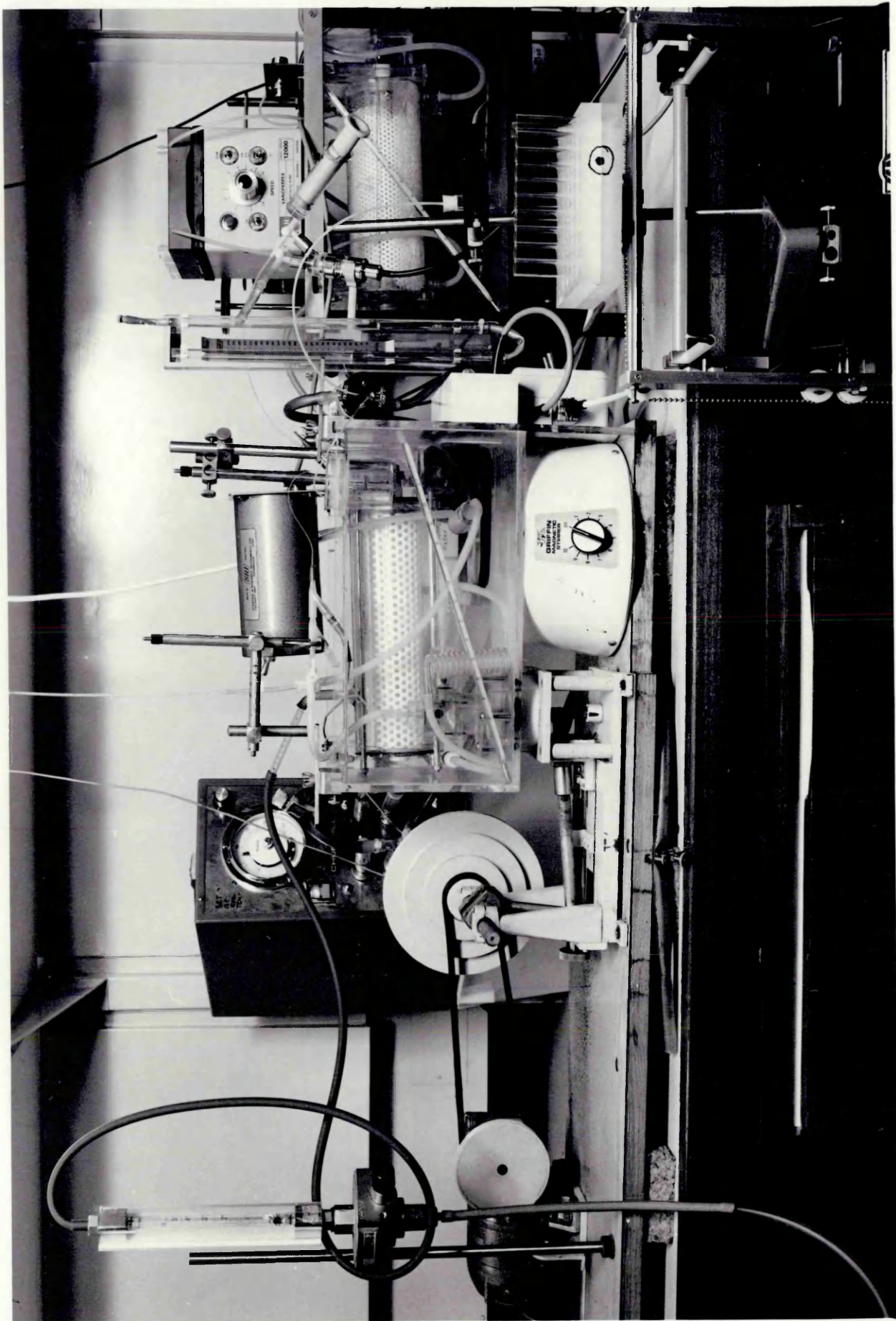
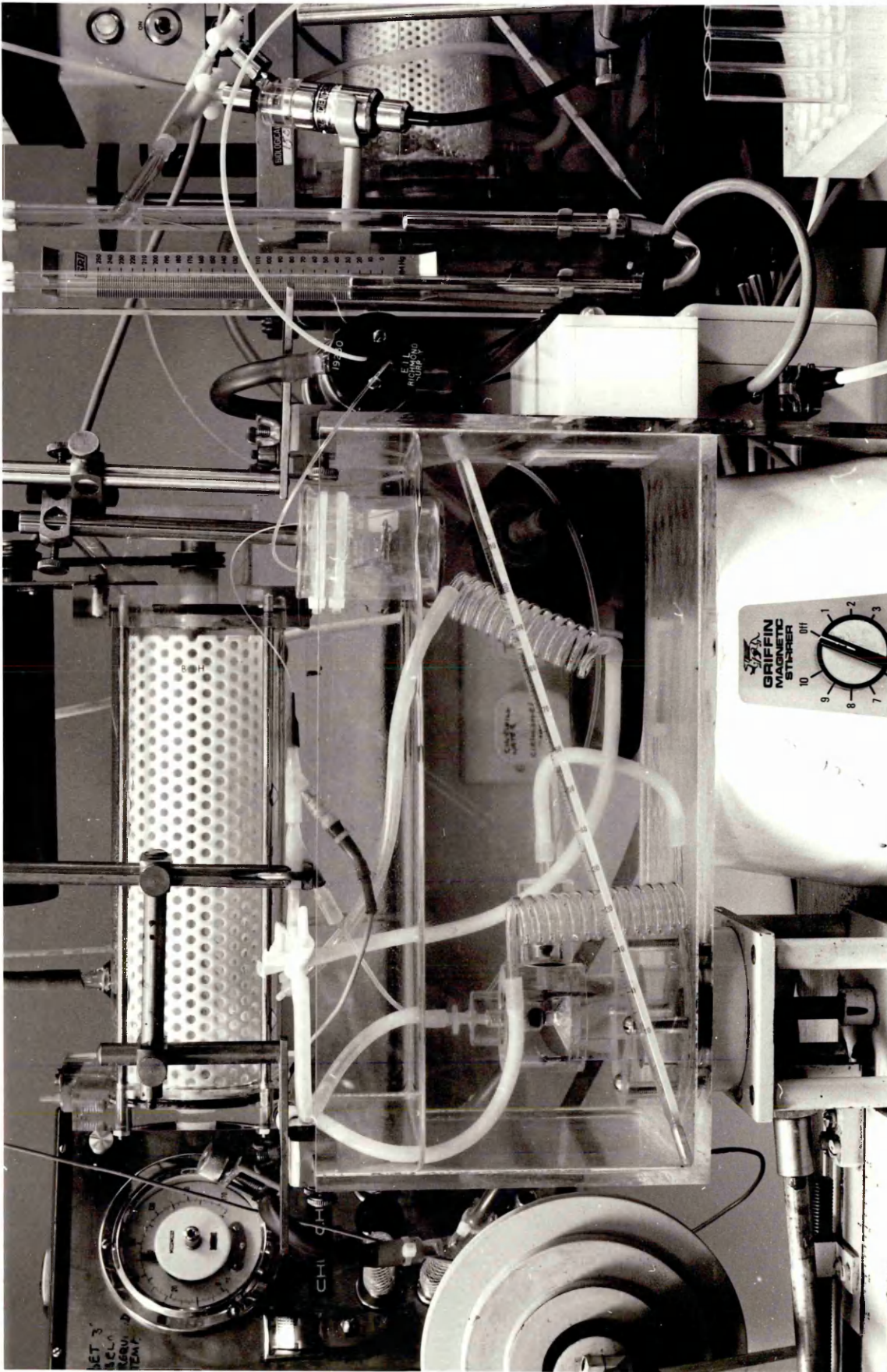

Figure 1a. Detail of the main water bath of the perfusion  
assembly



**Audio Visual Aids Unit**  
University of Surrey

**Neg. No.** 4075B/8

Key to numbers:

1.	Main water bath	12.	Drive belt	23.	Thermister
2.	Heating unit	13.	Peristaltic pump	24.	Luer-fitting tip of Y-tube
3.	Thermostat	14.	Glass-coil heat exchanger	24a.	Head of coeliac cannula
4.	Magnetic stirrer	15.	Bubble trap	25.	Perfusion chamber
5.	Oxygenator	16.	" "	26.	Oxygen electrode
6.	"	17.	Three-way tap	27.	Drop counter
7.	Electric motor	18.	" "	28.	Fraction collector
8.	Glass-coil heat exchanger	19.	Millipore filter holder	29.	Electronic temperature meter
9.	Dale-Schuster pump	20.	Polythene Y-tube	30.	PO <sub>2</sub> meter
10.	Stroke-volume monitor	21.	Mercury manometer	31.	Drop recorder unit
11.	Electric motor	22.	Pressure transducer	32.	EMMA (multichannel amplifier) and ultra-violet recorder.
				33.	Mercury thermometer.
				34.	Collection tubes.

Figure 2. Schematic diagram of the perfusion assembly.

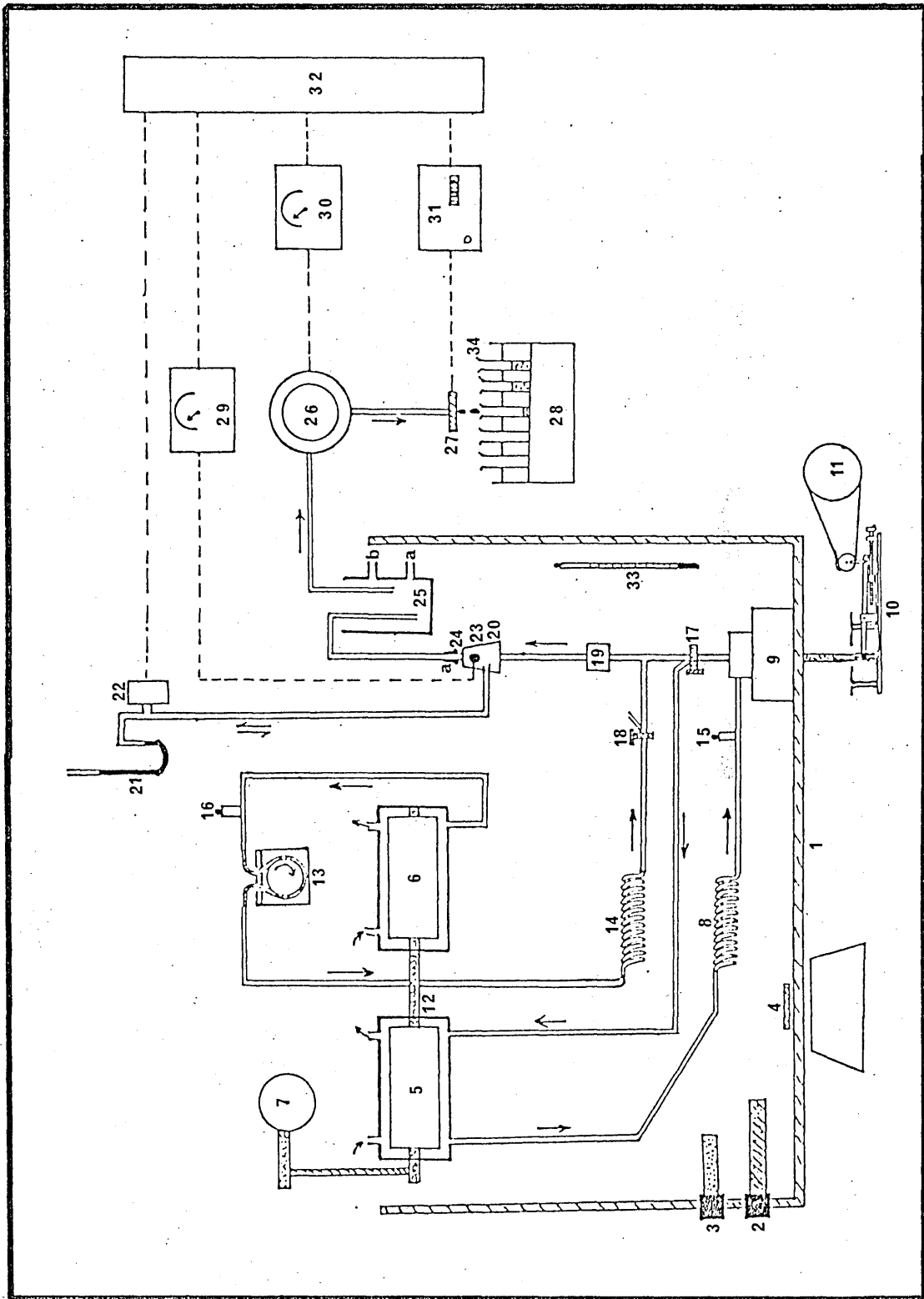



(220 volts, 700 Watts; SRI), and the temperature was maintained at a constant range ( $37.5^{\circ}\text{C} \pm 0.4^{\circ}$ ) by the thermostat (3) (Type T.S., N.C.  $\pm 20^{\circ}\text{C}$ , A.E.I. Ltd.). The uniformity of the bath temperature was ensured through continuous vigorous mixing of the water by the magnetic stirrer (4). Two rotating screen-cylinder oxygenators (5) and (6), contained separately in perspex jackets as perfusate reservoirs, were immersed in the bath (these rotating-screen cylinder oxygenators were a modification of that described by Ambeck, Beck Industries Inc., see Appendix 1). The first oxygenator (5) was run by an electric motor (7) (200-250 volts, S.R.I., Cat. No. 116). The cylinder revolved at forty revolutions per minute about its long axis. An outlet from this oxygenator's reservoir was connected by a silicon-rubber tube (internal diameter 2 mm) to a glass-coil heat exchanger (8) (internal diameter 3 mm; 12 turns, 2 mm apart; coil diameter 20 mm.) which lead to the pulsatile Dale-Schuster pump (9) (Dale and Schuster, 1928) with a variable stroke-volume monitor (10) and was driven by an electric motor (11). The pump ran at 145 strokes per minute. The second oxygenator (6) was connected through a drive belt (12) to the centre axis of oxygenator (5) and revolved the same; an outlet from its reservoir was connected to the peristaltic pump (13) (LKB, Varioperspex 12000, 240 volts) which was connected by a silicon-rubber tube (internal diameter 2 mm) to a glass-coil heat exchanger (14) which is the same as (8). Two bubble traps

(15) and (16) of 10 ml capacity were included in the circuit immediately before pumps (9) and (13) respectively. These bubble traps were used as safeguards against possible inclusion of air bubbles in the perfusates, although no frothing or foaming ever occurred in the oxygenators. They were included before both pumps in order to avoid dampening down the pulsatile pressure gradients in front of the pumps. A Millipore filter holder (19) (Swinex-25) contained a 0.22  $\mu$ m Millipore filter which removed any dust or large particle inclusions from the perfusates.

At position (20) the pumped perfusates entered a polythene Y-tube (internal diameter, 2 mm) which connected the main flow line on one side to a mercury manometer (21) and a Statham-type pressure transducer (22) (S.E. Laboratories, S.E. 4-81, Mk 2); the other limb of the Y-tube carried the main flow past the thermister (23) (A solid glass bead N.T.C. Thermister Type U<sub>23</sub>) which was connected to an electronic temperature metre (29) (Appendix 2). The perfusate flow continued into the main perfusion luer-fitting tip (24) which accommodated the coeliac cannula (24a) (Portex, Nylon Intravenous Cannula, external diameter 0.63 mm, 2 FG, 30 cm long, Green Luer).

The glass perfusion chamber (25) (Pyrex, 50 ml beaker; with a lower inlet (25a) and an upper outlet (25b): which served to exchange a normal saline solution used to bathe the isolated-perfused pancreas) was partly immersed in the water bath.

An oxygen electrode (26) (a modification of the  $PO_2$ -electrode of a Blood Gas Analyser, Model 48C, EIL Ltd.) led into a drop counter (27) connected to the electronic drop recorder (31) (Appendix 3).

An automatic fraction collector (28) (Microcol T80, Gilson, Anachem Ltd.) was modified to be a moving-tube rack instead of a moving dropper. An Electro-Medical Multi-channel Amplifier (EMMA, SE4001, SE IABS, Ltd.) together with an ultra-violet recorder (SE 3006, SE IABS, Ltd.) (32) were used to record outputs from all of:

- i. The pressure transducer (22).
- ii. Temperature displayed on the electronic temperature meter (29).
- iii. Partial pressure of oxygen from meter (30) of Blood Gas Analyser.
- iv. Drop interval displayed on the electronic drop-recorder (31).

Two three-way taps (K-75a, Robineta 3 direction, Dreiweghahn) were included in the circuit, tap (17) on the outlet from pump (9) and tap (18) immediately after glass-coil heat exchanger (14). The functions of the two taps will be described later. A mercury thermometer (33) ( $-10^{\circ}\text{C}$  to  $+110^{\circ}\text{C}$ ) was used to check the thermister-meter temperature readings. All connecting tubes used in the circuit were silicon-rubber tubes of internal diameter 2mm.

3. Operation of apparatus during perfusion:

The system of pancreas perfusion used was a once-through technique, i.e. the perfusates were not recycled through the preparation.

With the main bath (1) Fig. (2), already at  $37.5^{\circ}\text{C}$ , the two oxygenator reservoirs (5) and (6) were filled with normal saline solution and rotation was commenced. The two pumps (9) and (13) were put on, and the saline solution was let to circulate throughout all the glass and silicone-rubber tubes for thirty minutes, at the end of which the saline was removed. 130 ml of the basal perfusion medium (described later) were then put in the oxygenator reservoir (6) and 130 ml of stimulation perfusion medium (described later) were put in the oxygenator reservoir (5). These volumes of media partly filled the reservoirs and immersed the lower one third of the perforated screen-cylinders. Oxygenation was started. The gas supply ( $\text{O}_2 : \text{CO}_2, 95\% : 5\%$ )

was delivered at a rate of 200 ml/min. by passing it through a rotameter-type gas flow meter (Caplato Ltd.) then was passed into a humidifier (a 250 ml flask, containing 150 ml of normal saline), after which the humidified gas mixture went into an inlet in the oxygenator (5), from where it passed into the second oxygenator (6) and finally vented through an outlet on the second oxygenator. Pump (9) was started and tap (17) was turned away from the main flow direction and was connected through its third outlet by a silicon-rubber tube (17a) back to oxygenator (5), thus keeping the stimulation perfusion medium recirculating. Pump (13) was started at the same time and tap (18) was kept opened towards the main flow direction up to the luer-fitting outlet (24) where the flow entered a connecting cannula (Portex, Nylon Cannula, o.d. 2 mm, 80 cm long, yellow luer at both ends) which was connected in turn back to the oxygenator (6) and thus the basal perfusion medium was kept recirculating. For thirty minutes, both perfusion media were separately kept circulating by which time they were equilibrated with the oxygen and carbon dioxide.

The coeliac axis cannulation was completed, the connecting cannula was joined to the coeliac cannula, and the basal perfusion medium started perfusing the pancreas.

Once the cannulation of the hepatic portal vein was completed and the perfusate out-flow started, the connecting cannula was removed altogether and the coeliac cannula (24a) was joined directly to the main perfusion outlet (24). The outlet of the hepatic portal cannula was connected to the oxygen electrode (26) from where the flow was directed into the drop counter (27) and then into the sample collection tubes (34) (polythene, 0.5" x 3", round bottom tube, L./072, Luckham Ltd.) in the automatic fraction collector (28).

Perfusion was kept running as such for twenty minutes in order to achieve complete stabilisation. Collection of samples then started, one tube every five minutes. The basal perfusion medium was kept perfusing the pancreas to collect the first five tubes, after which tap (18) was closed and tap (17) was opened to the main flow thus starting the perfusion with the stimulation perfusion medium. This permitted the collection of fifteen tubes, making a total of twenty tubes in one hundred minutes. Perfusion pressure was kept at  $85 \pm 10$  mm Hg, depending on flow resistance of the preparation, to maintain an average outflow of 2.5 ml/5 min. Sample tubes were immediately removed and frozen at  $-10^{\circ}\text{C}$  for later analysis. All sample collection was done between 1600 and 1800 hours G.M.T. (It was reported that the mean concentration of insulin in plasma measured at 1730 hours is very stable - Okajima and Ui, 1978).

A once-through normal saline solution at 37.5°C, and flow-rate of 6 ml/min. entered the perfusion chamber (25) at its lower inlet (25a) and was drained out from the upper outlet (25b); this provided a stable, warm and wet surrounding for the perfused pancreas and washed out pancreatic and other enzymes that might have been released in the chamber.

At the termination of each experiment, the perfused preparation was removed from the perfusion setup and a 10% methylene blue solution was injected through the coeliac cannula until it flowed out of the hepatic portal cannula. The pancreatic tissue stained with methylene blue was microdissected and removed, blot-dried by lightly pressing it between filter papers for five minutes and then was weighed. This was designated as the wet weight of the perfused pancreas.

#### 4. Cleaning the perfusion apparatus:

After each experiment the whole assembly was disassembled and all glassware, perspex, silicon-rubber tubing and cannulae were rinsed with tap water overnight and then washed with detergent and thoroughly rinsed with tap water, followed by distilled water and left to dry.

### III. Perfusion media

In general, a selected perfusion medium must meet certain requirements in order to achieve normal function of an organ in vitro; such a medium has to supply all the essential factors which the organ receives in vivo, taking special care not to introduce any harmful effectors. Thus, an optimum medium has to accomplish the following:

- i. a sufficient oxygen-carrying capacity
- ii. an adequately buffered physiological pH, usually 7.4, i.e. arterial pH.
- iii. a physiological concentration of the principal ions (such as in Krebs-Henseleit bicarbonate medium (1932) as cited in Ross (1972)).
- iv. a sufficient colloidal osmotic pressure, especially in the absence of blood, to balance the hydrostatic and tissue pressures.

The perfusion medium which was chosen for this investigation was Krebs-Henseleit bicarbonate medium (1932), which was described by Dawson, Elliott, Elliott and Jones (1969) and Ross (1972), and was used by many researchers with various alterations (Curry et al., 1968-a,b; Loubatières et al., 1967; Sussman et al., 1966); it was made up of the following stock solutions:

- |                                 |  |
|---------------------------------|--|
| 1. NaCl (0.154 mol/l)           | 4. $\text{KH}_2\text{PO}_4$ (0.154 mol/l)                  |
| 2. KCl (0.154 mol/l)            | 5. $\text{MgSO}_4 \cdot 7\text{H}_2\text{O}$ (0.154 mol/l) |
| 3. $\text{CaCl}_2$ (0.11 mol/l) | 6. $\text{NaHCO}_3$ (0.154 mol/l).                         |



All salts were analytical quality (Analar, BDH). The sodium bicarbonate solution was bubbled with 100% CO<sub>2</sub> gas for one hour in order to convert any carbonate to bicarbonate ions, before preparing the following mixture: 100 parts (volume) of solution (1) were mixed with 4 parts of solution (2), 3 parts of solution (3), one part of solution (4), one part of solution (5) and 21 parts of solution (6). Thus, the final concentration of solutes in the solution were: 118.5 mmol/l NaCl, 4.7 mmol/l KCl, 2.5 mmol/l CaCl<sub>2</sub>, 1.2 mmol/l KH<sub>2</sub>PO<sub>4</sub>, 1.2 mmol/l MgSO<sub>4</sub>·7H<sub>2</sub>O and 24.9 mmol/l NaHCO<sub>3</sub>. In case any turbidity of the solution was observed, it was reversed and cleared by bubbling a 5% CO<sub>2</sub> gas (CO<sub>2</sub>:O<sub>2</sub>, 5%:95%) for ten minutes.

To this solution the following were added:

- a. Dextran (Clinical grade, average Mol. Wt. 83300, Sigma Chemical Co.) at a final concentration of 4 gm/100 ml solution (Grodsky et al., 1963) for the maintenance of colloid osmotic pressure.
- b. Adenosine (Anhydrous, Mol. Wt. 267.2, Sigma Chemical Co.) at a final concentration of 1.5 mmol/l (Davis and Mephram, 1971, 1974), which maintains the integrity of the endothelial cells (Salzman, Chambers

and Neri, 1966) and acts as a vasodilator of blood vessels (Davis and Mephram, 1971, 1974; Wolf and Berne, 1956).

c. Glucose (D (+) glucose-Dextrose, Mol. Wt. 180.16, Analar, Searle Co.) at the following final concentrations:

1. 5.0 mmol/l in the basal perfusion medium, which is considered as a weak non-stimulatory concentration of glucose in rats (Loubatières-Mariani et al., 1973; Malaisse et al., 1967 a,b).
2. 18.87 mmol/l in the stimulation perfusion medium, which is a very potent stimulatory concentration of glucose in rats reported by many investigators (Curry et al., 1968-a,b; Curry, 1971; Grodsky et al., 1963; Loubatières-Mariani et al., 1973; Malaisse et al., 1967 a,b).

Perfusate mixtures were filtered through a Whatman No. 1 filter paper in order to remove any dust or insoluble particles. To two separate 26 ml volumes of basal perfusion medium and stimulatory perfusion medium, 0.5 ml of FX-80 (perfluoro-2-butyl tetrahydrofuran, ICN pharmaceuticals, Inc.) were added. Each volume with the added FX-80 was subjected to ultrasonic disintegration (Sloviter and Kamimoto, 1967) for two minutes with an MSE 150 Watts (20 K Hz) disintegrator fitted with a 3.2 mm exponential probe.

The resulting suspension was homogenous and milky; and upon microscopic examination it showed uniform dispersal of FX-80 into droplets 6-9  $\mu$  in diameter, which was stable for two hours or more. These separate suspensions of FX-80 were returned to the basal and stimulatory perfusion media respectively, making the final volume of each 130 ml. No serum albumin was included in the perfusates because it was observed, in pilot experiments, that its absence did not affect the secretory response of the perfused pancreas, confirming the remark made by Joost, Beckmann, Holze, Lenzen, Poser and Hasselblatt (1976).

The basal and the stimulatory perfusion media were put separately in the two screen oxygenators, and both were oxygenated by a humidified gas mixture ( $O_2:CO_2$ , 95%:5%) for thirty minutes prior to the start of perfusion. Inflow and outflow pH of both media was the same (7.3), thus the buffer capacity was adequate. Both media, the basal and the stimulatory, were used in perfusing all the pancreases of this research; furthermore, in the five sets of experiments designed to establish a noradrenaline dose-response effect, the following noradrenaline (Levophed) concentrations, per 100 ml solution, were each simultaneously included in both media : 5 ng, 20 ng, 40 ng, 80 ng and 100 ng. It has been reported that the circulating noradrenaline level in normal rats is  $25 \pm 3$  ng/100 ml (Grobecker, Sarrvedra, McCarty, Chiveh and Kopin, 1977), whereas Benedict et al., (1977 b) reported that the noradrenaline content of plasma in rats is  $188 \pm 8$  ng/100 ml. Other relative works report the injection of 40  $\mu$ g or 50  $\mu$ g noradrenaline per 100 g intact rat (Holak, Baldys, Jarzab,

Wystrychowsky and Skrzypek, 1978; Kuroshima, Doi, Yahata and Ohno, 1977). Finally, in the set of experiments performed to study the simultaneous effects of noradrenaline and phentolamine, on the cold-acclimated rat pancreas, both the basal and the stimulatory perfusion media were used with the addition of 100 ng noradrenaline and 50 µg phentolamine (Rogitine, CIBA) per 100 ml of each of the media (Malaisse et al., 1967 b)

#### IV. Preparation and isolation of the pancreas for perfusion

To isolate and perfuse an organ, especially the rat pancreas, is relatively a tedious technique. Nevertheless, the complexity of such a perfusion is becoming reduced as simpler designs of isolation procedures and perfusion apparatus become available. Grodsky et al., (1963) introduced the technique of perfusing the isolated pancreas in a block of tissue including all of the pancreas, stomach, spleen and duodenum; this technique was adopted by many investigators (Basake, et al., 1971; Loubatières et al., 1967, 1973; Penhos, Wu, Basake, Lopez and Wolff, 1969). Thus, the aim of the preparation was to isolate in one physiological unit all of: the pancreas, the duodenum, the spleen and the stomach, after proper cannulation of the coeliac axis and the hepatic portal vein.

A rat, fasted for twenty hours, was weighed and then anaesthetized by intraperitoneal injection with Nembutal (pentobarbitone sodium, 60 mg Nembutal/ml, Abbot Labs. Ltd.) at a dose of 5.5 mg/100 gm bodyweight, (Ross, 1972).

With the rat supine and its limbs extended, a mid-line incision was made through the skin and the abdominal wall from the pubis to the manubrium sterni, along the linea alba. The cut abdominal wall was slightly retracted laterally. A cotton wool pad dampened with warm normal saline was placed over the abdominal organs to prevent drying. The dorsal aorta Fig. (3) was located in the lumbar region posterior to the renal arteries and was separated from the inferior vena cava and connective tissue for a short distance (approx. one centimeter) where a loose ligature (1) Fig. (3) was placed. By displacing the intestine, the stomach and the spleen to the right side of the animal, the dorsal aorta was located anterior to the left renal artery where the superior mesenteric artery and the coeliac axis branch. The area was cleaned of fat tissue, and a loose ligature (2) was placed around the aorta between the superior mesenteric artery and the coeliac axis. A third ligature (3) was placed around the aorta anterior to the coeliac axis in the vicinity of the crura of the diaphragm. The superior adrenal artery was located and ligated by ligature (4). Three branches from the coeliac axis: the left gastric artery, the right gastric artery and the hepatic artery were located and ligated by three ligatures (5, 6, 7). Blood vessels of the spleen were collected in three adjacent groups and tied within three ligatures (8, 9, 10). Two loose ligatures (11) and (12) were placed around the gastro-hepatic ligament.

At this stage, ligature (3) was firmly tied and, immediately, a small incision was made in the wall of the aorta posterior to ligature (1) and a cannula (Portex, Nylon Intravenous Cannula, external

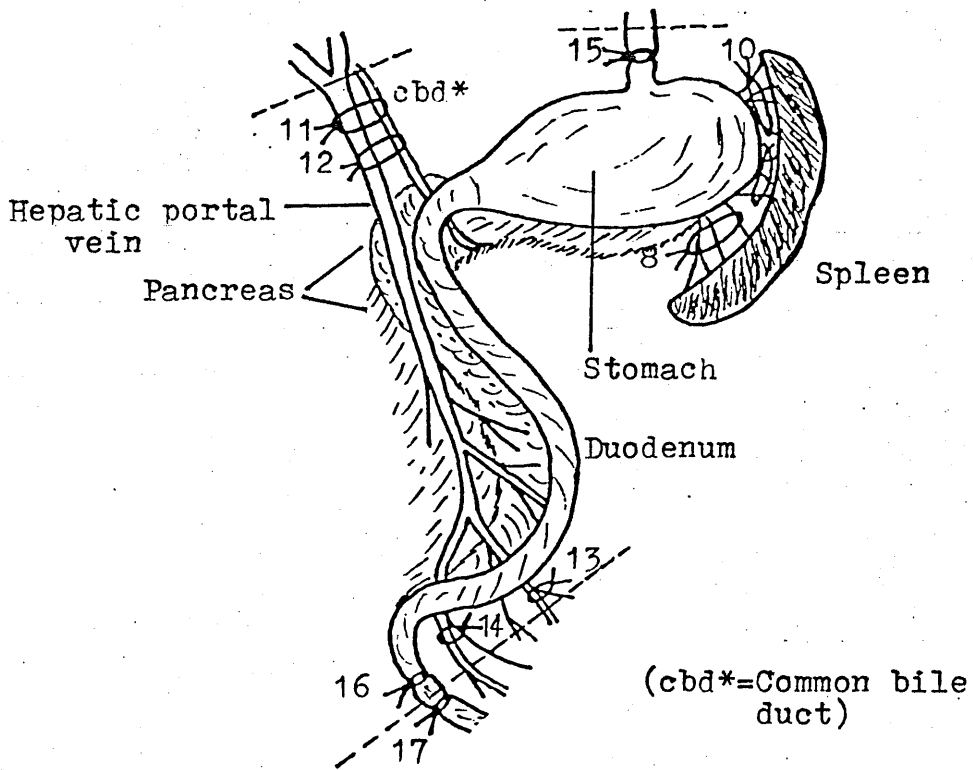
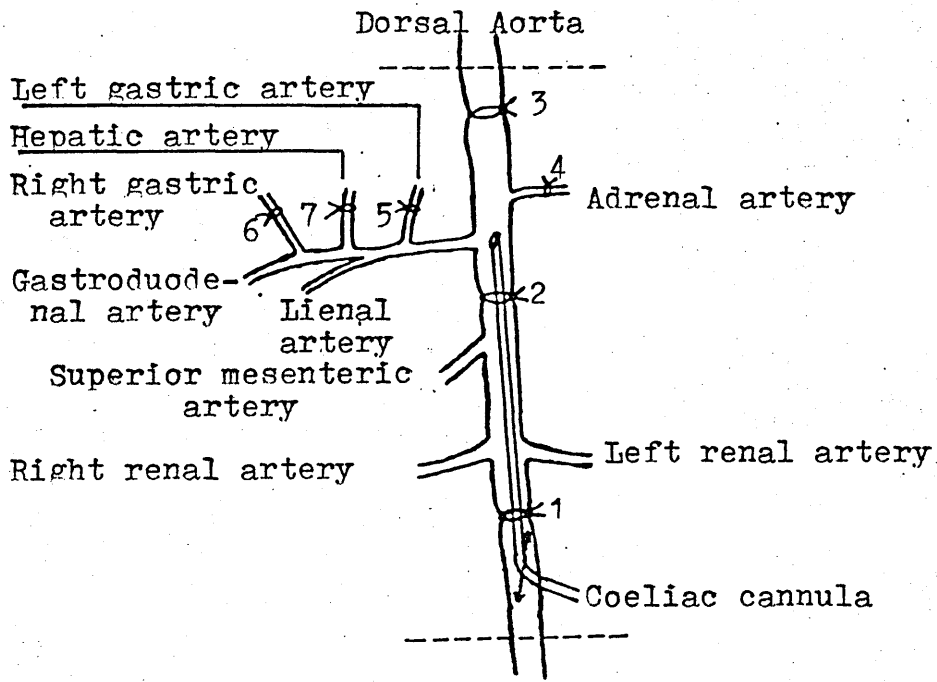

Figure 3. Schematic diagrams of the rat dorsal aorta and the major arteries (a), and the isolated perfused unit (b), for ligatures (1-17) refer to text. (----) indicates position of cuts.

diameter 0.63 mm, Luer mount), cut to 15 cm length, was introduced forward inside the aorta, till its tip reached the origin of the coeliac axis, Ligatures (1) and (2) were then tied and 0.1 ml (2 I.U.) heparin (Heparin, 1000 I.U. per ml; diluted 1:50 in normal saline) was introduced (Penhos et al., 1969) into the cannula, which was then connected to the main flow of the basal perfusate from the perfusion main output tip, by a thick cannula (Portex, Nylon Cannula, external diameter 2mm, 80 cm long, Luer connector at both ends).

A slit was made in the wall of the hepatic portal vein, between ligature (11) and the entry of the hepatic portal vein into the liver. Once it was ensured that a perfusate outflow was taking place from this slit, a 15 cm cannula (Portex, the same as the aortic cannula but no luer fitting) was introduced for a distance of about 5 mm inside the portal vein. The two ligatures (11) and (12) were tightened and tied. A slit was made in the wall of the common bile duct between ligature (12) and the pancreas in order to allow outflow of any exocrine secretion from the pancreas and prevent possible local oedema. Two ligatures (13) and (14) were placed around the major vessels leading into the hepatic portal vein from the parts of the intestines beyond the duodenum.

The oesophagus was ligated close to the stomach and cut distally (15). Two ligatures (16) and (17) were placed and tied around the junction of the duodenum and the jejunum, and a cut inbetween the two ligatures was made.

The aorta was separated posterior to ligature (1) and anterior to ligature (3), and the segment between these two points was freed of all dorsal attachments, thus the pancreas, the duodenum, the stomach, the spleen, the aortic segment with its coeliac cannula and the hepatic portal vein and its cannula were isolated in one block. The whole unit was washed twice with warm normal saline solution and transferred to the main perfusion chamber in the water bath. The coeliac cannula was connected directly to the main perfusion flow tip, after the removal of the thick connecting cannula. The entire operation took thirty to forty minutes, with a maximum of two minutes anoxia during the coeliac axis cannulation.

The viability of the isolated perfused pancreas was assessed according to the following criteria:

- 1) The positive secretory response of the perfused pancreas to a glucose load.
- 2) Arterio-venous oxygen differences.
- 3) Glucose uptake by the perfused pancreas (and other tissues).
- 4) Increasing vascular resistance (a sign of failure of the perfusion - this usually happened after at least one hundred minutes of perfusion).
- 5) The physical appearance of the perfused pancreas and peristaltic movements of the duodenum.



## ACQUISITION AND PROCESSING OF DATA

### I. Glucose analysis:

Determinations of the glucose concentrations in both the basal and the stimulatory perfusion media were carried out prior to perfusion in every experiment as well as all the samples collected individually and in duplicates. The method used was a commercial kit form of the enzymatic glucose oxidase technique (GOD-PERID Method, The Boehringer Corporation, London, Ltd.), which is summarized as follows: 0.1 ml (measured by Eppendorf Microlitre Pipette, 100  $\mu$ l) of unknown glucose solution was added to 1ml of distilled water and 0.1 ml of this diluted solution was incubated for thirty minutes at 37°C, with 5 ml of reagent (100 mmol/l phosphate buffer pH = 7.0; 20  $\mu$ g peroxidase (POD)/ml; 180  $\mu$ g glucose oxidase (GOD)/ml; 1.0 mg Azinoethyl-benthiazoline sulphonate (PERID)/ml). Glucose is oxidised by the specific enzyme of glucose oxidase (GOD) to gluconolactone which, in aqueous solution in the presence of peroxidase (POD), is converted to gluconic acid:

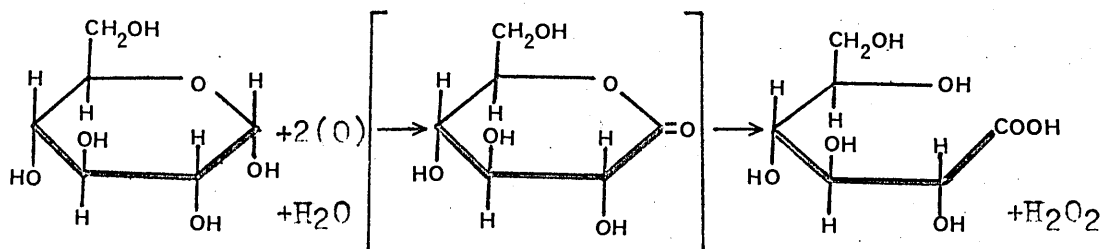

the hydrogen peroxide (H<sub>2</sub>O<sub>2</sub>) produced in the above reaction oxidises the chromogen (PERID) to form a dye:

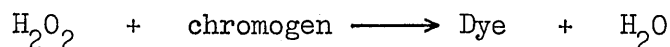

the intensity of the dye is proportional to the glucose concentration and was measured at a wavelength of 640 nm in a Beckman Spectrophotometer (DB-GT, Beckman Instruments, INC.). The standard curve for glucose was linear up to values of 19.43 mmol/l.

## II. Insulin assay:

Determinations of insulin concentrations in the collected samples of each experiment were done in duplicate by a Sephadex-adsorbed-antibody radioimmunoassay method (Phadebas Insulin Test-Pharmacia Diagnostics) where the separation of bound from unbound insulin is carried out by the specific antibodies coupled by covalent linkages to a solid phase which is the activated sephadex particles suitable for radioimmunoassay (Wide & Porath 1966); after incubation the bound and free antigen are separated by centrifugation.

Each Phadebas Insulin Test Kit contains the following reagents:

- (1) Sephadex-Anti-Insulin Complex, antibodies raised in guineapigs (Lyophilized).
- (2) Insulin standard 320  $\mu$ U/ml after reconstitution (Lyophilized).
- (3) Insulin  $^{125}\text{I}$  : 8 ng; about 3  $\mu$ Ci (at date of manufacture (Lyophilized).
- (4) Buffer substance, 4.2 gm (dry powder).
- (5) Phadebas Decanting-Aid-solution: 5 ml diluted to 250 ml using normal saline solution.

To prepare the standard curve, the insulin standard solution (320  $\mu$ U/ml) is diluted with buffer solution to obtain suitable concentrations within the range 5-320  $\mu$ U/ml; performed by serial double

dilutions using the standard stock solution to obtain the following standard concentrations: 320, 160, 80, 40, 20, 10 and 5  $\mu\text{U}/\text{ml}$ . The buffer is used as "zero" insulin sample. Plastic tubes (Polythene, LP4 round bottom tube, L./072, Luckham Ltd.) were used for the following test procedure:

- (1) 0.1 ml of standards 5-320  $\mu\text{U}/\text{ml}$  and "zero" insulin was pipetted into tubes (Set I) each in duplicate.
- (2) 0.1 ml of unknowns was pipetted into tubes (Set II) each in duplicate.
- (3) 0.1 ml of the insulin  $^{125}\text{I}$  solution was pipetted into each of the tubes of sets I and II.
- (4) 1.0 ml Sephadex Anti-Insulin complex suspension was pipetted into each of the tubes of Sets I and II.
- (5) The tubes of both sets were stoppered and maintained overnight at room temperature on a rotary incubator which served to keep the particles in suspension.
- (6) Tubes of both sets were centrifuged at 2000 Rev./min. in a refrigerated centrifuge (Mistral 2L, MSE), for two minutes at  $4^{\circ}\text{C}$ , in order to remove droplets from the stoppers.
- (7) 1.5 ml of phadebas decanting-aid solution (used to speed up and facilitate precipitation) were added to all tubes of both sets.

(8) Tubes of both sets were centrifuged at 2000 Rev./min. for five minutes and at 4°C. The supernatants were decanted to the last drop.

(9) Radioactivity in tubes of both sets, as well as two tubes each containing 0.1 ml  $^{125}\text{I}$  solution (total activity) was determined by using a Well-type gamma-counter (Gamma Sample Counter, GTL 300-500, Wallac Decem Series). The anode tension was 1.086 KV, the discriminator level was 2.18 volts, and the channel width (counting window) was 1.8 volts. The efficiency of the counter was 55%. The counting time of each sample was 240 seconds.

### III. Evaluation of oxygen uptake:

The oxygen carrying capacity of the perfusion media was assessed after an oxygen dissociation curve was established for a given amount of perfusion medium containing the oxygen carrier FX-80 (perfluoro-2-Butyl tetrahydrofurans). The amount of oxygen taken up, i.e. the oxygen content of the medium in terms of  $\text{ml}(\text{O}_2)/100 \text{ ml}$  (medium) was related to the partial pressure of the oxygen ( $\text{PO}_2$ ) equilibrated with it.

The perfusion medium was put in the oxygenator of the perfusion setup kept at a bath temperature of 37.5°C and was oxygenated by a humidified gas mixture ( $\text{O}_2:\text{CO}_2, 2\%:5\%, 93\% \text{N}_2$ ) for twenty five minutes after which a 2 ml sample was analysed for total oxygen content by the Van Slyke method. The same procedure

was repeated for different gas mixtures containing 3.5, 5, 6.5, 8, 21 and 40% oxygen while keeping the CO<sub>2</sub> percentage constant at 5%, the rest was N<sub>2</sub>. Total oxygen content of each sample was determined and expressed in (ml) of oxygen per (100 ml) perfusion medium at s.t.p. An oxygen dissociation curve was constructed accordingly by plotting total oxygen content versus corresponding partial pressures of oxygen (Appendix 4).

Prior to the start of perfusion in each experiment, partial pressures of oxygen in the perfusion media were measured by the oxygen electrode and these readings were considered to represent the arterial oxygen tension; the venous oxygen tensions were measured throughout the whole perfusion process by passing the venous outflow through the oxygen electrode. The arterial and the venous oxygen tensions were expressed in mm Hg, at 37.5°C .

#### IV. Volume flow of perfusates:

The volume of each sample was calculated as the product of the number of drops collected for that sample by the volume of one drop, which was estimated after repeated precise measurements of the volume of one hundred drops of perfusion media passed through the same dropper head and was confirmed by comparison of weights of equal volumes of the same medium.

V. Calculations and statistical analyses:

1. Glucose concentration:

Calculation of the glucose concentration of the prepared perfusion media as well as the collected samples was based on the comparison of the optical density (E) of the unknown samples with the optical density of the standard (5.55 mmol/l), hence the glucose concentration was calculated from the expression 
$$\frac{E \text{ (sample)}}{E \text{ (standard)}} \times 5.55$$

The results were expressed in (mmol/l). The reported concentrations of glucose in each experiment were the averages of duplicates of each sample.

Differences between glucose concentrations of perfusing media and corresponding samples collected from each experiment, represented the glucose uptake by the perfused block of tissue. Uptake was presented as millimoles glucose per gram tissue per hour (mmol/g/h).

2. Insulin secretion rate:

The count rate (CR) of radioactivity for each of the standards was expressed as a percentage of the <sup>MCR</sup>maximum count rate (MCR) of the "zero" insulin sample after the subtraction of the background counts. The percentage values obtained for the insulin standards were plotted against the logarithm of insulin concentration on semi-logarithmic graph paper, thus a standard curve was constructed. Similarly, the average count rate for each of

the unknowns was expressed as a percentage of (MCR) in the same way as for the standards. The concentration of insulin was read from the standard curve ( in  $\mu\text{U}/\text{ml}$ ) for each of the unknown samples. The insulin secretion rate of each sample collected was expressed as micro units of insulin per gram of wet weight of pancreas per five minutes (sample collection time) i.e.  $\mu\text{U}/\text{g}/5 \text{ min.}$ , which was calculated as follows: 
$$\frac{C \times V}{W} \text{ per } 5 \text{ min.}$$

where C = insulin concentration ( $\mu\text{U}/\text{ml}$ ); V = volume of sample (ml), W = Wet weight of pancreas (g). Results of each experiment were plotted in a histogram of insulin secretion rate versus time. The results of each set of experiments were analysed statistically by grouping replicate samples and calculating their means and standard errors of the means (s.e) and were plotted in a histogram of the mean value of insulin secretion rate of each sample  $\pm$  s.e. versus time in minutes.

### 3. The student-t-test:

The final analysis of the research, intended to compare the means of data obtained from the different sets of experiments performed with different conditions and/or different experimental parameters, was the student-t-test for matched paired samples (two tailed test), which compared two mean values of insulin secretion rates of comparable standing and showed whether they were significantly different or not, taking into consideration their variances.

The critical significances point in these analyses was taken at probability  $p \leq 0.05$ , at the corresponding degrees of freedom (df) of the number of replicates of each value concerned.



## RESULTS

The results of the six sets of experiments are presented here in the order in which the different categories of experimental animals were discussed earlier. A typical insulin assay standard curve and a general comment on the measurement of oxygen uptake are included prior to the experimental results.

### I. Insulin assay standard curve:

Standard curves of insulin concentration versus percentage activity were plotted on semilogarithmic graph paper and all conformed to the typical pattern shown in Fig. (4). Standards of 320  $\mu\text{U}$  insulin/ml showed  $25 \pm 1.5$  (Mean  $\pm$  s.e.) % of total radioactivity bound and the 5  $\mu\text{U}$  insulin/ml showed  $90.5 \pm 1.0$  (Mean  $\pm$  s.e.) % of total radioactivity bound. None of the experimental samples fell outside the above range of standards.

The standard insulin used was porcine insulin Fig. (4) and the insulin antibody of the sephadex-anti insulin complex was raised in guineapigs. A rat standard insulin sample  $20.7 \pm 3$  I.U./mg (generously supplied by Mr. R. L. Cooper, Diagnostics Division, Pharmacia (G.B.) Ltd.) was tested for cross reactivity with the Sephadex-anti insulin complex of the insulin assay kit. The examination showed a higher binding capacity by the rat insulin than that of the porcine insulin for values more than 20  $\mu\text{U}/\text{ml}$ , and lower for values less than 20  $\mu\text{U}/\text{ml}$  Fig. (4). Results of insulin concentrations in all the experiments were expressed in micro

% Activity bound

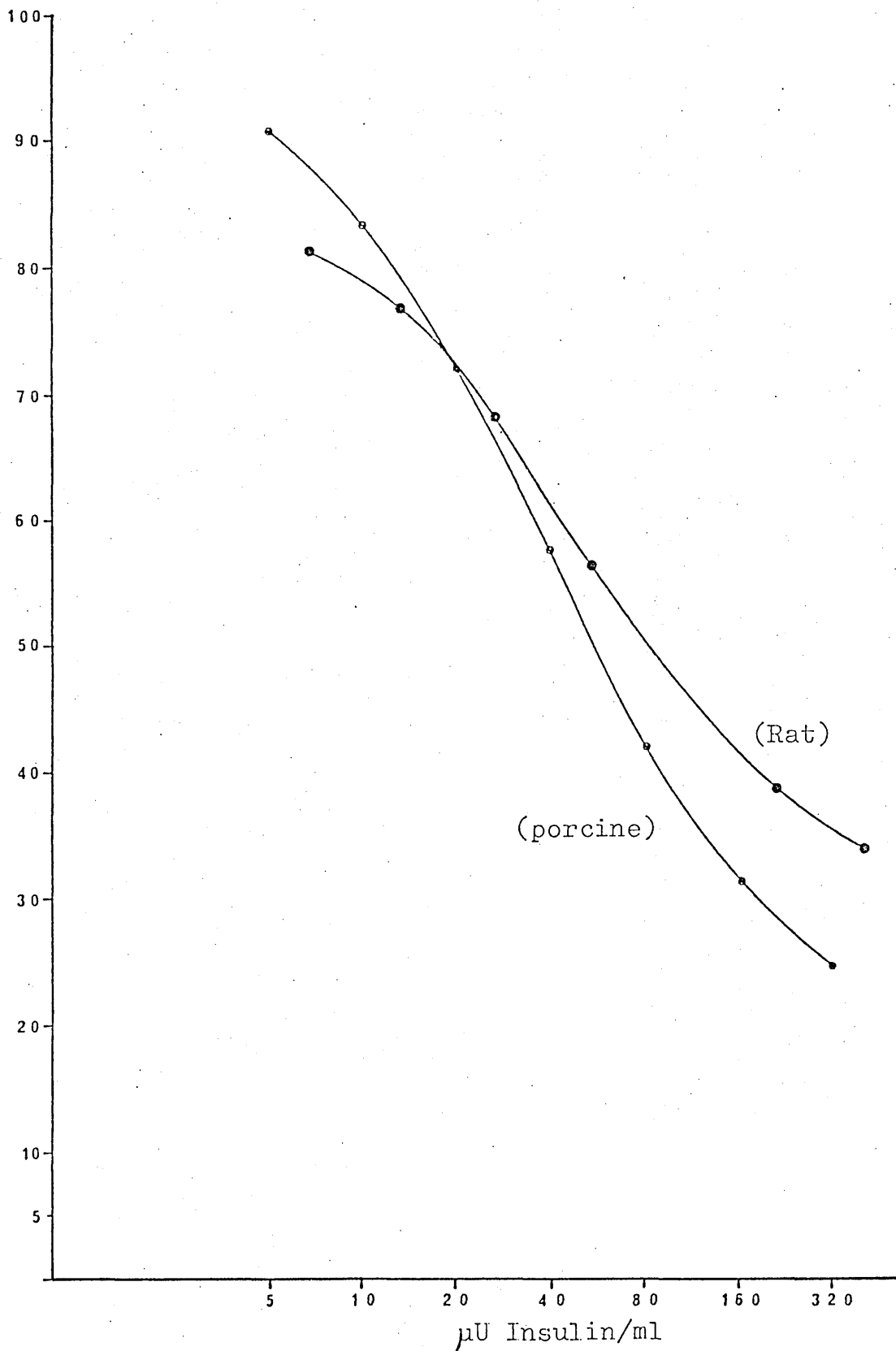

Figure 4. Standard curves for rat and porcine insulin as obtained from radioimmunoassay.

international units of insulin per millilitre perfusate ( $\mu\text{U}/\text{ml}$ ) as equivalents of porcine insulin. This reflects relative change of insulin concentration values and serves the purpose of the investigation adequately.

## II. Oxygen uptake:

In all the pancreas perfusion experiments performed, the "arterio-venous" (i.e. input-output) oxygen tension differences ranged between 240 and 260 mm Hg. The perfusate "arterial" (input) oxygen tension, after thirty minutes of equilibration with  $\text{O}_2:\text{CO}_2$  (95%:5%), ranged between 345 and 365 mm Hg (Mean  $\pm$  s.e. = 360 mm Hg  $\pm$  2.6); on the other hand the "venous" (output) oxygen tension was 106 mm Hg  $\pm$  2.3. Precise values of oxygen uptake by the perfused block of tissue were not calculated because this arterio-venous oxygen tension difference did not demonstrate a net oxygen delivery with reference to the oxygen dissociation curve constructed for the perfusion media with (FX-80) as the oxygen carrier (Appendix 4). Nevertheless, oxygen carried physically in a dissolved form in the perfusion medium seems to have been enough to sustain the perfused block of tissue in a normal physiological state for a total perfusion period of two hours and exhibiting uptake of glucose, insulin release in response to glucose stimulation and peristaltic movements of the duodenum.

## III. Insulin secretion in the main control group:

Results of the main control groups, i.e. from non cold-exposed animals, of pancreas perfusion experiments are summarized

Table 1: Data obtained from outflow of perfused pancreases of the main control set of rats

Sample	Volume ml	Glucose concentration mmol/l	Insulin concentration $\mu$ U/ml	Insulin secretion rate $\mu$ U/g/5 min.
1	2.15 $\pm$ 0.03	3.71 $\pm$ 0.17	38.75 $\pm$ 5.09	94.51 $\pm$ 11.68
2	2.14 $\pm$ 0.04	3.67 $\pm$ 0.17	38.58 $\pm$ 6.07	94.34 $\pm$ 14.16
3	2.14 $\pm$ 0.04	3.83 $\pm$ 0.28	39.78 $\pm$ 6.51	97.43 $\pm$ 15.57
4	2.145 $\pm$ 0.04	4.07 $\pm$ 0.27	39.63 $\pm$ 5.48	97.15 $\pm$ 12.89
5	2.15 $\pm$ 0.03	4.34 $\pm$ 0.22	41.33 $\pm$ 5.25	101.38 $\pm$ 11.92
6	2.12 $\pm$ 0.04	4.85 $\pm$ 0.33	47.58 $\pm$ 7.21	115.50 $\pm$ 4.64
7	2.14 $\pm$ 0.03	9.11 $\pm$ 0.69	59.20 $\pm$ 7.16	144.61 $\pm$ 15.51
8	2.15 $\pm$ 0.03	12.55 $\pm$ 0.69	73.17 $\pm$ 4.98	179.44 $\pm$ 8.57
9	2.15 $\pm$ 0.04	12.29 $\pm$ 0.64	60.50 $\pm$ 4.47	148.22 $\pm$ 7.39
10	2.12 $\pm$ 0.03	13.73 $\pm$ 0.58	57.33 $\pm$ 7.05	139.09 $\pm$ 10.53
11	2.13 $\pm$ 0.02	13.96 $\pm$ 0.53	63.33 $\pm$ 6.59	153.82 $\pm$ 9.09
12	2.15 $\pm$ 0.03	13.85 $\pm$ 0.40	67.88 $\pm$ 4.08	166.43 $\pm$ 3.60
13	2.15 $\pm$ 0.03	13.79 $\pm$ 0.44	62.75 $\pm$ 4.67	154.36 $\pm$ 9.74
14	1.95 $\pm$ 0.04	13.31 $\pm$ 0.69	65.13 $\pm$ 8.95	144.80 $\pm$ 12.45
15	2.15 $\pm$ 0.03	13.36 $\pm$ 0.65	54.42 $\pm$ 6.99	133.99 $\pm$ 16.09
16	2.15 $\pm$ 0.03	13.11 $\pm$ 0.62	55.90 $\pm$ 5.99	137.21 $\pm$ 12.92
17	2.14 $\pm$ 0.04	13.95 $\pm$ 0.62	61.92 $\pm$ 8.10	151.22 $\pm$ 16.92
18	2.13 $\pm$ 0.03	13.20 $\pm$ 0.60	55.87 $\pm$ 6.03	136.25 $\pm$ 11.28
19	2.15 $\pm$ 0.03	13.31 $\pm$ 0.68	58.90 $\pm$ 7.07	144.73 $\pm$ 14.10
20	2.15 $\pm$ 0.03	13.38 $\pm$ 0.62	58.59 $\pm$ 5.83	143.96 $\pm$ 12.92

- i) In all cases, n = 6
- ii) Mean body weight of animals = 246.33  $\pm$  8.34 g
- iii) Mean wet weight of pancreas = 0.875  $\pm$  0.40 g
- iv) All values are expressed as the mean and the standard error of the mean.

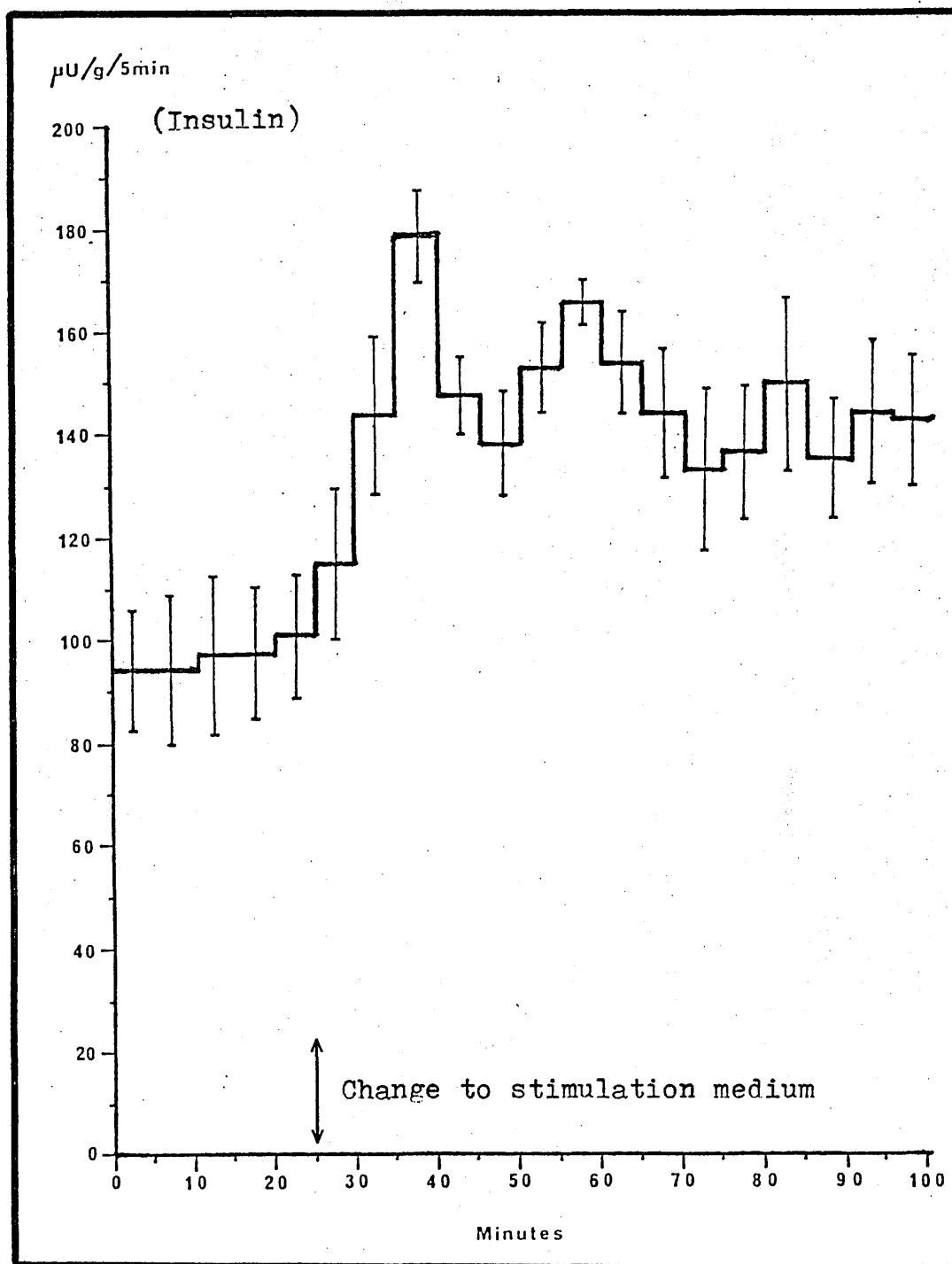

Figure 5. Histogram of insulin secretion rates vs. time, in the main control group, showing the basal rate and the biphasic insulin secretion rates in response to glucose stimulation. Values are the means of six samples and the vertical bars represent the standard errors of the means in each case.

in Table (1) and Fig. (5). Six rats with body weight  $246.3 \pm 8.3$  (s.e.m.) g were used to prepare the perfusion assembly with a mean pancreatic wet weight of  $0.875 \pm 0.040$  g. The average perfusion flow rate was  $2.13 \pm 0.01$  ml/5 min. and the perfusion pressure ranged between 80 and 94 mm Hg. Glucose concentration in the basal perfusion medium was  $3.92 \pm 0.11$  mmol/l ( $70.63 \pm 1.98$  mg%); and in the stimulation (i.e. high glucose concentration) perfusion medium, glucose concentration was  $13.54 \pm 0.13$  mmol/l ( $243.97 \pm 2.34$  mg%).

The basal insulin secretion rate (at zero to twenty five minutes perfusion time) ranged between  $94.34 \pm 14.16$   $\mu$ U/g/5 min. and  $101.38 \pm 11.92$   $\mu$ U/g/5 min., i.e. in the first five samples collected during the 25 min. of basal medium perfusion. Following a change from basal to stimulation medium, the insulin secretion rate increased and perfusion with the stimulation medium was maintained for a further 75 minutes, after which the experiment was concluded. The expected biphasic secretion pattern of insulin (Basake et al., 1971; Bennett, Curry and Curry, 1973; Cerasi and Luft, 1967; Curry, 1971; Füssganger, Hinz, Goberna, Jaros, Karsten, Pfeiffer & Raptis, 1969; Gerhards and Ruel, 1974; Grodsky et al., 1963, 1970; Katada and Ui, 1977; Kidson and Lazarus, 1973; Lenzen and Hasselblatt, 1974; Lerner, 1977; Loubatières, Alric, Mariani and Chapal, 1972; Loubatières and Loubatières-Mariani, 1974; Pfeiffer, Füssganger, Hinz and Raptis, 1970) is evident after a glucose load of 8.33 mmol/l or more was applied, Fig. (5). A peak pulse of insulin release  $179.44 \pm 8.57$   $\mu$ U/g/5 min. (mean  $\pm$  s.e.) was

achieved within five minutes of the stimulation medium reaching the pancreas. This first phase of insulin release was followed by a drop in the rate of release to  $139.09 \pm 10.53 \mu\text{U/g/5 min.}$ , after which the second phase commenced and remained within the range  $133.99 \pm 16.09$  to  $166.43 \pm 3.60 \mu\text{U/g/5 min.}$  during the period of observation. The insulin secretion rates of both phases are significantly greater than that seen during perfusion with the basal medium ( $p < 0.001$ ). In response to glucose stimulation, insulin released in the first phase of secretion, which lasted for approximately five minutes, is about 10% of that released during the observed fifty minutes of the second phase.

Glucose uptake by the block of perfused tissue (which included the major part of the pancreas, a segment of the duodenum and some fat in close association with the pancreatic tissue) was observed to differ, depending on whether the basal medium or the stimulation medium was perfusing the block of tissue. The glucose uptake was estimated from the following values:

- a - Average glucose concentration in basal medium .....  $4.506 \text{ mmol/l.}$
- b - Average glucose concentration in stimulation medium .....  $16.750 \text{ mmol/l.}$
- c - Average glucose concentration in the first five samples .....  $3.924 \text{ mmol/l.}$
- d - Average glucose concentration in the last ten samples .....  $13.540 \text{ mmol/l.}$

- e - Average volume of samples  
 ..... 2.132 ml/5 min.
- f - Average wet weight of perfused tissue  
 ..... 2 g.

Glucose uptake from basal medium =  $7.445 \times 10^{-3}$  mmol/g/hour;  
 and glucose uptake from the stimulation medium =  $4.106 \times 10^{-2}$   
 mmol/g/hour.

#### IV. Insulin secretion in cold-acclimated animals:

The rats, undergoing cold-acclimation at  $4^{\circ}\text{C}$ , tolerated the low temperature successfully, mortality rate being 4%. Results of the pancreas perfusion experiments from the cold-acclimated rats are summarized in Table (2) and Fig. (6).

Six rats of average body weight of  $4.39.5 \pm 7.9$  g were used to prepare the isolated perfused pancreases which had a mean wet weight of  $1.119 \pm 0.0941$  (s.e.m.) g. Average perfusion flow rate was  $1.14$  ml/5 min and the perfusion pressure ranged between 90 and 95 mm Hg. Glucose concentration in the basal perfusion medium was  $4.25$  mmol/l, and in the stimulation perfusion medium glucose concentration was  $15.91$  mmol/l. The basal rate of insulin release ranged between  $19.50 \pm 6.61$   $\mu\text{U/g/5 min.}$  and  $25.70 \pm 5.59$   $\mu\text{U/g/5 min.}$  The biphasic pattern of insulin release in response to glucose stimulation is evident: the first phase of release peaked at  $38.60 \pm 5.02$   $\mu\text{U/g/5 min.}$  and occurred within 15 minutes of the shift into the high glucose load of the stimulation medium; the second phase of insulin release appeared ten to fifteen minutes after the first phase and ranged between  $27.10 \pm 3.51$   $\mu\text{U/g/5 min.}$  and



Table 2: Data obtained from outflow of perfused pancreases of the cold-acclimated set of rats

Sample	Volume ml	Glucose concentration mmol/l	Insulin concentration $\mu$ U/ml	Insulin secretion rate $\mu$ U/g/5 min.
1	1.24 $\pm$ 0.13	3.32 $\pm$ 0.15	24.80 $\pm$ 8.83	23.30 $\pm$ 5.88
2	1.20 $\pm$ 0.13	3.42 $\pm$ 0.15	21.90 $\pm$ 9.46	19.50 $\pm$ 6.61
3	1.18 $\pm$ 0.13	3.55 $\pm$ 0.11	24.48 $\pm$ 9.41	20.90 $\pm$ 5.39
4	1.20 $\pm$ 0.13	3.65 $\pm$ 0.13	26.88 $\pm$ 10.01	23.80 $\pm$ 5.67
5	1.26 $\pm$ 0.14	3.85 $\pm$ 0.19	28.37 $\pm$ 10.20	25.70 $\pm$ 5.59
6	1.18 $\pm$ 0.13	5.01 $\pm$ 0.53	31.92 $\pm$ 9.85	28.40 $\pm$ 4.94
7	1.12 $\pm$ 0.13	7.34 $\pm$ 0.83	35.13 $\pm$ 9.65	29.90 $\pm$ 4.94
8	1.13 $\pm$ 0.15	12.75 $\pm$ 0.50	44.66 $\pm$ 9.53	38.60 $\pm$ 5.02
9	1.16 $\pm$ 0.16	12.91 $\pm$ 0.37	35.95 $\pm$ 10.43	30.70 $\pm$ 4.41
10	1.12 $\pm$ 0.14	13.22 $\pm$ 0.34	33.08 $\pm$ 10.22	27.90 $\pm$ 4.33
11	1.10 $\pm$ 0.14	13.46 $\pm$ 0.26	31.10 $\pm$ 10.08	25.50 $\pm$ 4.49
12	1.09 $\pm$ 0.15	13.63 $\pm$ 0.34	34.33 $\pm$ 10.84	27.10 $\pm$ 3.51
13	1.11 $\pm$ 0.14	13.51 $\pm$ 0.34	35.13 $\pm$ 10.16	29.60 $\pm$ 4.41
14	1.10 $\pm$ 0.15	13.05 $\pm$ 0.54	33.63 $\pm$ 10.37	27.10 $\pm$ 3.67
15	1.07 $\pm$ 0.15	13.84 $\pm$ 0.33	35.37 $\pm$ 10.23	27.90 $\pm$ 3.76
16	1.08 $\pm$ 0.14	13.85 $\pm$ 0.26	37.12 $\pm$ 10.00	30.40 $\pm$ 4.86
17	1.08 $\pm$ 0.13	13.14 $\pm$ 0.34	37.83 $\pm$ 9.59	31.30 $\pm$ 5.31
18	1.09 $\pm$ 0.13	13.11 $\pm$ 0.35	32.33 $\pm$ 9.24	26.90 $\pm$ 4.78
19	1.11 $\pm$ 0.13	13.34 $\pm$ 0.29	34.61 $\pm$ 9.52	29.36 $\pm$ 3.95
20	1.09 $\pm$ 0.13	13.22 $\pm$ 0.36	33.80 $\pm$ 8.95	28.15 $\pm$ 3.75

- i) In all cases, n = 6
- ii) Mean body weight of animals = 439.5  $\pm$  7.92 g
- iii) Mean wet weight of pancreas = 1.1185  $\pm$  0.094 g
- iv) All values are expressed as the mean and the standard error of the mean.

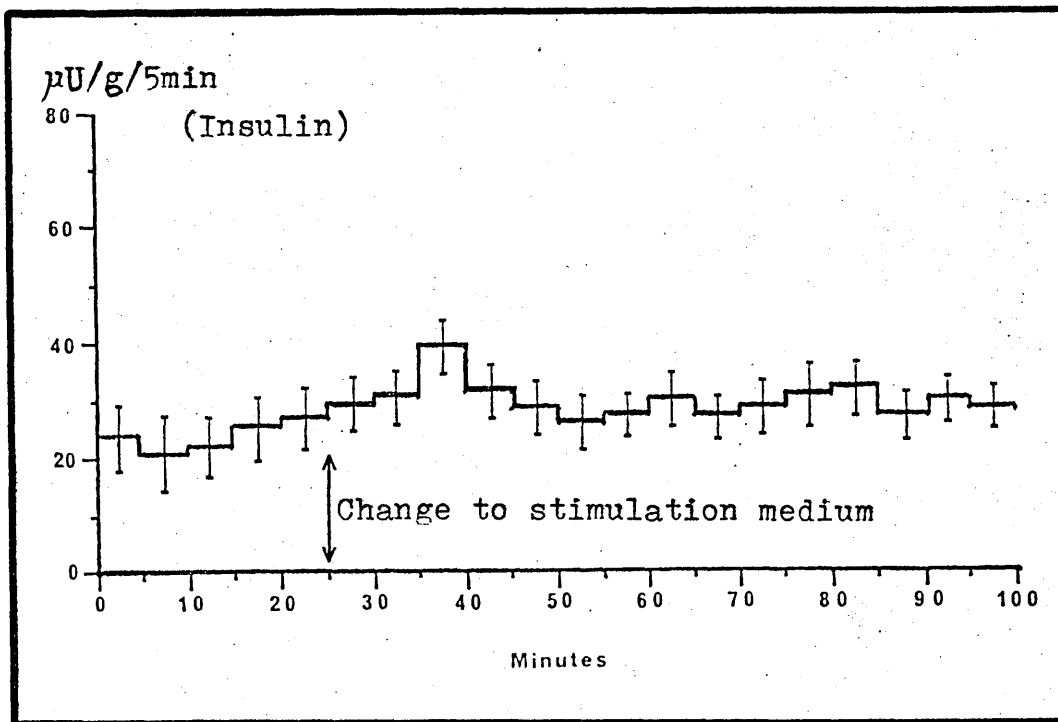

Figure 6. Histogram of insulin secretion rates vs. time, in the cold-acclimated group, showing the basal rate and the effect of glucose stimulation on insulin release. Values are the means of six samples, and the vertical bars represent the standard errors of the means, in each case.

31.30 ± 5.31 µU/g/5 min. The differences between the insulin secretion rate at the peak of the first phase and those of the basal rate of release were highly significant (p < 0.001) and the differences between the rate of insulin release of the peak of the second phase and all samples of the basal rate were significant (p < 0.05). Insulin released in the first phase after glucose stimulation was about 12% of that released during the second phase for 45 minutes.

Glucose uptake by the block of perfused tissue was 4.717 x 10<sup>-3</sup> mmol/g/hour from the basal medium and 1.713 x 10<sup>-2</sup> mmol/g/hour from the stimulation medium.

V. Noradrenaline dose-response effect on insulin secretion

The purpose of this set of experiments is to study the effect of locally applied noradrenaline on insulin release from the pancreatic islets and to evaluate quantitatively the amount of noradrenaline needed for maximal effect.

Results of the five sets of experiments, each set comprising six preparations and at a different noradrenaline concentration in the perfusion media, are summarized in Table (3) and Fig. (7).

With the noradrenaline concentration at 5 ng/100 ml of perfusate, the insulin release in response to glucose load followed the general biphasic pattern Fig. (7-a). The basal insulin secretion rate during the perfusion of the basal medium ranged between 85.2 ± 0.6 µU/g/5 min. and 97.7 ± 7.5 µU/g/5 min.

Table 3: Data obtained from outflow of pancreases perfused with different noradrenaline (NA) concentrations. Pancreases were isolated from normal control rats

Sample	5ng(NA)/100 ml	20ng(NA)/100 ml	40ng(NA)/100 ml	80ng(NA)/100 ml	100ng(NA)/100 ml
Insulin Secretion Rates $\mu\text{U/g/5 min.}$					
1	90.5	76.4	59.8	52.4	52.8
2	85.2	62.8	59.7	51.7	52.4
3	94.5	70.7	63.5	51.4	53.6
4	92.8	69.0	58.2	51.5	52.7
5	89.7	72.2	58.2	52.5	53.4
6	91.0	79.2	60.2	55.7	53.2
7	97.7	92.8	73.4	56.6	54.1
8	129.6	100.6	86.2	58.9	55.0
9	87.9	81.6	69.4	59.0	55.1
10	99.3	81.8	70.6	63.0	55.5
11	103.2	87.7	72.5	69.9	56.2
12	105.8	91.2	67.3	74.5	56.7
13	121.7	93.7	75.5	73.9	59.3
14	115.7	95.3	75.6	72.2	61.6
15	114.9	94.0	77.4	64.2	62.3
16	126.4	95.1	76.2	73.3	63.2
17	129.9	95.4	77.2	72.2	62.7
18	128.6	94.4	77.1	74.2	63.1
19	143.2	92.2	75.8	72.7	63.4
20	145.6	92.7	75.0	72.7	63.5
	2.2	+ 2.0	+ 4.1	+ 1.4	+ 1.4
	0.6	+ 1.7	+ 4.7	+ 1.4	+ 1.7
	8.2	+ 0.7	+ 4.2	+ 0.8	+ 1.7
	5.2	+ 2.0	+ 2.1	+ 1.0	+ 1.3
	2.3	+ 2.1	+ 4.8	+ 1.2	+ 1.2
	5.3	+ 5.4	+ 1.2	+ 2.1	+ 2.6
	7.5	+ 2.5	+ .06	+ 2.0	+ 2.4
	4.7	+ 2.4	+ 2.0	+ 2.8	+ 2.3
	1.0	+ 1.5	+ 2.3	+ 1.9	+ 1.9
	10.1	+ 3.5	+ 1.1	+ 2.1	+ 1.6
	10.4	+ 3.1	+ 1.5	+ 3.0	+ 1.6
	9.0	+ 2.7	+ 1.7	+ 3.7	+ 2.4
	8.0	+ 2.9	+ 1.6	+ 1.1	+ 4.1
	7.4	+ 1.8	+ 2.5	+ 1.5	+ 4.5
	1.4	+ 1.3	+ 2.0	+ 1.5	+ 6.1
	8.4	+ 2.2	+ 2.0	+ 1.5	+ 6.1
	5.5	+ 0.8	+ 2.5	+ 0.9	+ 5.3
	3.5	+ 0.9	+ 2.6	+ 1.0	+ 5.8
	10.7	+ 0.6	+ 1.4	+ 0.6	+ 5.7
	5.5	+ 0.5	+ 1.8	+ 1.2	+ 5.1
				+ 0.5	+ 6.3

i) In all cases, n = 6

ii) All values are expressed as the mean and standard error of the mean.

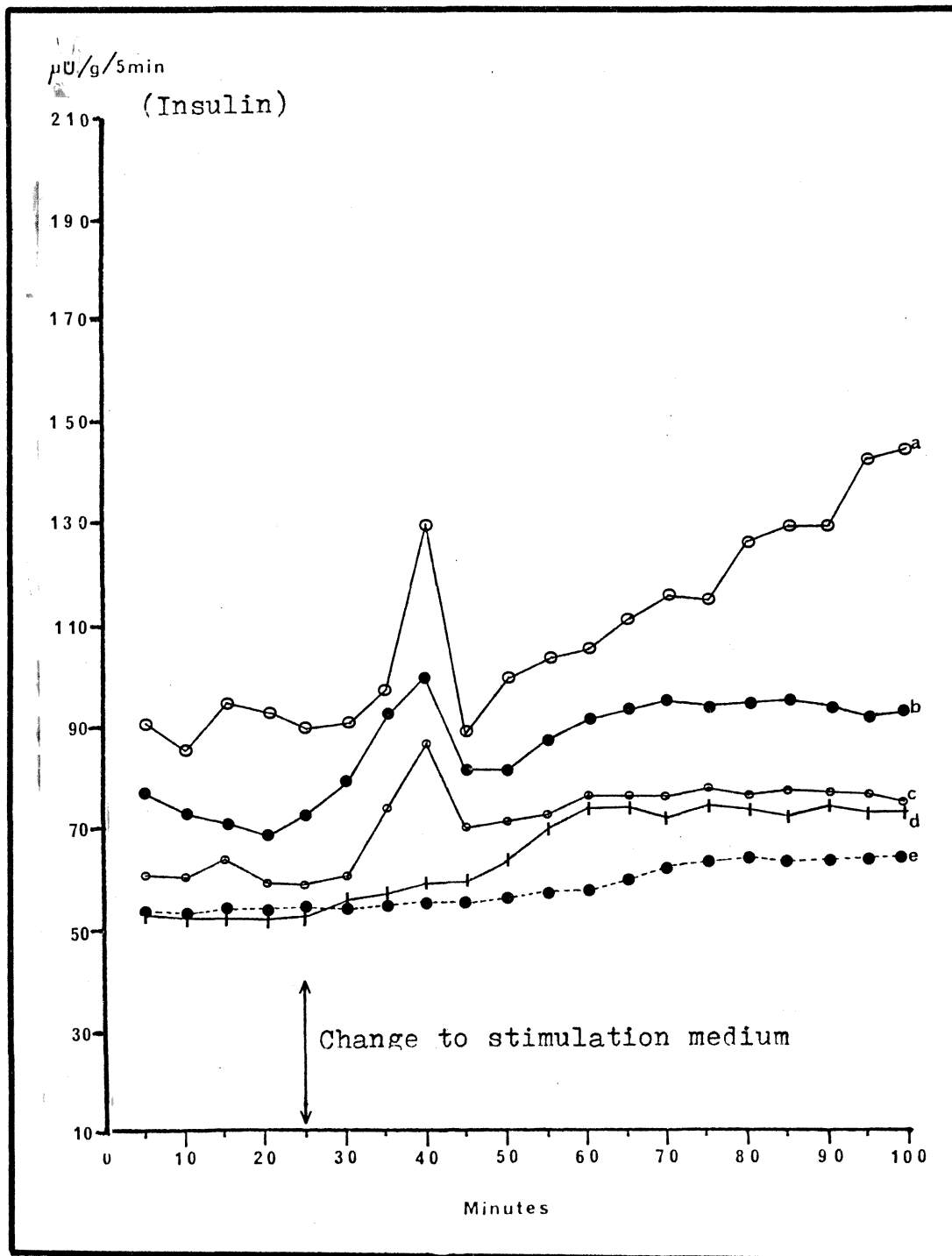

Figure 7. Noradrenaline dose-effect on insulin secretion rates basal and in response to glucose stimulation. Noradrenaline concentrations included in both perfusion media were:  
 (a) 5, (b) 20, (c) 40, (d) 80 and (e) 100 ng/100 ml.  
 Each point represents the mean of six samples.

The first phase of insulin release, in response to glucose stimulation, peaked at  $129.6 \pm 4.7 \mu\text{U/g/5 min.}$ , which subsided after five minutes. The second phase of insulin release ranged between  $103.2 \pm 10.4 \mu\text{U/g/5 min.}$  and  $145.6 \pm 5.5 \mu\text{U/g/5 min.}$  The overall result, by point to point comparison, was a slight suppression of insulin release in comparison with the normal control set. Nevertheless, the first six samples which denoted the basal insulin release were found to be not significantly different ( $p \geq 0.5$ ) from the normal control set; the first phase of insulin release on the next four samples, were significantly lower than the control ( $p < 0.02$ ); the second phase of insulin release on the last eight samples were not significantly different ( $p \geq 0.5$ ) from the control.

Increasing the noradrenaline concentration to 20 ng/100 ml perfusate Fig. (7-b), and to 40 ng/100 ml perfusate Fig. (7-c), resulted in a further suppression of insulin release, but the biphasic pattern of insulin release was still persistent. The basal insulin release, during the perfusion with 20 ng/100 ml noradrenaline, was not significantly different from the control; whereas with 40 ng/100 ml noradrenaline infusion the basal insulin release was significantly lower than the control ( $p < 0.04$ ). Insulin secretion rates in response to glucose stimulation in the presence of either 20 ng or 40 ng noradrenaline per 100 ml perfusion media, were all significantly lower than the control (both phases of release) ( $P < 0.01$ ).

When the noradrenaline concentration was increased to 80 ng/100 ml perfusate, Fig. (7-d), and still higher to 100 ng/100 ml perfusate, Fig. (7-e), the pattern of insulin release was completely changed. The biphasic pattern was abolished and there was no evidence of a sharp first phase of release. However during the 80 ng noradrenaline per 100 ml perfusion, the glucose loads of 16.14 and 16.32 mmol/l had an overall stimulating effect which resulted in a slight increase in the rate of insulin release ranging between  $63.0 \pm 2.1$  and  $72.7 \pm 0.5$   $\mu\text{U/g/5 min.}$  These insulin secretion rates were significantly higher than the basal insulin secretion rates of the same set ( $p < 0.02$ ). During the 100 ng noradrenaline per 100 ml perfusion, the stimulated insulin secretion rates ranged between  $55.5 \pm 1.6$  and  $63.5 \pm 6.3$   $\mu\text{U/g/5 min.}$ , which in comparison with the basal secretion rates of the same set that ranged between  $51.4 \pm 0.8$  and  $53.4 \pm 1.2$   $\mu\text{U/g/5 min.}$ , were slightly higher ( $p < 0.05$ ). All values of insulin secretion rates of both sets of experiments at 80 ng and 100 ng noradrenaline per 100 ml perfusate, were significantly lower than corresponding values (basal, first and second phases) of insulin secretion rates of the main control group ( $P < 0.001$ ).

VI. Insulin secretion after cold-acclimation and in the presence of noradrenaline and phentolamine in the perfusates

Following the noradrenaline dose-response control experiments, the next set was performed with noradrenaline (100 ng/100 ml) in both the basal and the stimulation media, together with phentolamine

(50  $\mu\text{g}/100\text{ ml}$ ) the alpha-adrenergic antagonist, which was expected to abolish the inhibitory effect of noradrenaline on insulin release from the pancreatic islets.

Results of this set of experiments are summarized in Table (4) and Fig. (8). Six rats with an average body weight of  $309 \pm 6.2\text{ g}$  were used to prepare the pancreas perfusions. The average wet weight of the perfused pancreases was  $0.871 \pm 0.044\text{ g}$ . The average perfusion flow rate was  $1.90 \pm 0.02\text{ ml}/5\text{ min}$ . The perfusion pressure ranged between 92 and 108 mm Hg. Glucose concentration in the basal medium was  $4.15\text{ mmol}/\text{l}$  and in the stimulation medium was  $15.14\text{ mmol}/\text{l}$ . The basal rate of insulin secretion ranged between  $28.35 \pm 7.39\text{ }\mu\text{U}/\text{g}/5\text{ min}$ . and  $38.17 \pm 6.53\text{ }\mu\text{U}/\text{g}/5\text{ min}$ . Stimulation with the glucose load resulted in a first phase of insulin release which peaked at  $51.38 \pm 7.96\text{ }\mu\text{U}/\text{g}/5\text{ min}$ . and then subsided to lead into a second phase of insulin release ranging between  $38.72 \pm 8.82\text{ }\mu\text{U}/\text{g}/5\text{ min}$ . and  $47.82 \pm 7.51\text{ }\mu\text{U}/\text{g}/5\text{ min}$ . Thus, the general biphasic secretion pattern of insulin once again became evident. The differences between the mean values of the peak of the first phase and those of the basal secretion rate are highly significant ( $p < 0.001$ ), and the differences between the mean values of the second phase of insulin release and those of the basal range are significant ( $p < 0.05$ ). Insulin released in the first phase after glucose stimulation was about 13.4% of that released during the second phase of release for forty five minutes. Glucose uptake by the block of perfused tissue was calculated to be  $2.46 \times 10^{-3}\text{ mmol}/\text{g}/\text{hour}$  from the basal perfusion medium and  $1.255 \times 10^{-2}\text{ mmol}/\text{g}/\text{hour}$  from the stimulation medium.



Table 4: Data obtained from outflow of pancreases  
in the presence of both noradrenaline and  
phentolamine in both perfusion media. Pancreases were isolated  
from cold-acclimated rats

Sample	Volume ml	Glucose concentration mmol/l	Insulin concentration $\mu$ U/ml	Insulin secretion rate $\mu$ U/g/5 min.
1	1.97 $\pm$ 0.06	3.91 $\pm$ 0.09	13.12 $\pm$ 3.14	30.23 $\pm$ 7.37
2	1.95 $\pm$ 0.05	3.93 $\pm$ 0.07	12.57 $\pm$ 3.22	28.35 $\pm$ 7.39
3	1.87 $\pm$ 0.07	3.96 $\pm$ 0.08	13.35 $\pm$ 3.17	29.05 $\pm$ 7.10
4	1.94 $\pm$ 0.09	3.92 $\pm$ 0.06	15.02 $\pm$ 2.74	33.50 $\pm$ 6.08
5	1.98 $\pm$ 0.08	3.95 $\pm$ 0.05	15.77 $\pm$ 2.56	35.82 $\pm$ 5.96
6	1.92 $\pm$ 0.09	6.61 $\pm$ 0.18	17.28 $\pm$ 2.95	38.17 $\pm$ 6.53
7	1.89 $\pm$ 0.06	11.25 $\pm$ 0.26	21.37 $\pm$ 3.61	46.43 $\pm$ 7.68
8	1.90 $\pm$ 0.06	13.76 $\pm$ 0.25	23.60 $\pm$ 3.81	51.38 $\pm$ 7.96
9	1.87 $\pm$ 0.05	14.08 $\pm$ 0.25	19.43 $\pm$ 2.96	41.77 $\pm$ 6.08
10	1.93 $\pm$ 0.07	14.08 $\pm$ 0.24	16.38 $\pm$ 3.06	35.97 $\pm$ 6.41
11	1.89 $\pm$ 0.04	14.06 $\pm$ 0.24	16.73 $\pm$ 3.25	36.10 $\pm$ 6.65
12	1.93 $\pm$ 0.04	14.06 $\pm$ 0.25	17.45 $\pm$ 3.90	38.22 $\pm$ 8.16
13	1.88 $\pm$ 0.04	14.05 $\pm$ 0.23	21.75 $\pm$ 3.97	46.43 $\pm$ 7.80
14	1.88 $\pm$ 0.04	13.98 $\pm$ 0.26	22.18 $\pm$ 3.64	47.82 $\pm$ 7.51
15	1.91 $\pm$ 0.06	14.03 $\pm$ 0.25	21.68 $\pm$ 3.88	37.65 $\pm$ 8.21
16	1.88 $\pm$ 0.04	14.03 $\pm$ 0.27	20.97 $\pm$ 3.74	46.00 $\pm$ 8.08
17	1.87 $\pm$ 0.04	13.98 $\pm$ 0.27	18.60 $\pm$ 4.63	39.05 $\pm$ 8.98
18	1.87 $\pm$ 0.06	14.02 $\pm$ 0.25	19.17 $\pm$ 4.27	40.98 $\pm$ 8.74
19	1.83 $\pm$ 0.05	14.06 $\pm$ 0.26	18.75 $\pm$ 4.76	39.55 $\pm$ 9.76
20	1.85 $\pm$ 0.04	14.06 $\pm$ 0.25	18.20 $\pm$ 4.24	38.72 $\pm$ 8.82

- i) In all cases, n = 6
- ii) Mean body weight of animals = 309  $\pm$  6.21 g
- iii) Mean wet weight of pancreas = 0.871  $\pm$  0.044 g
- iv) All values are expressed as the mean and the standard error of the mean.

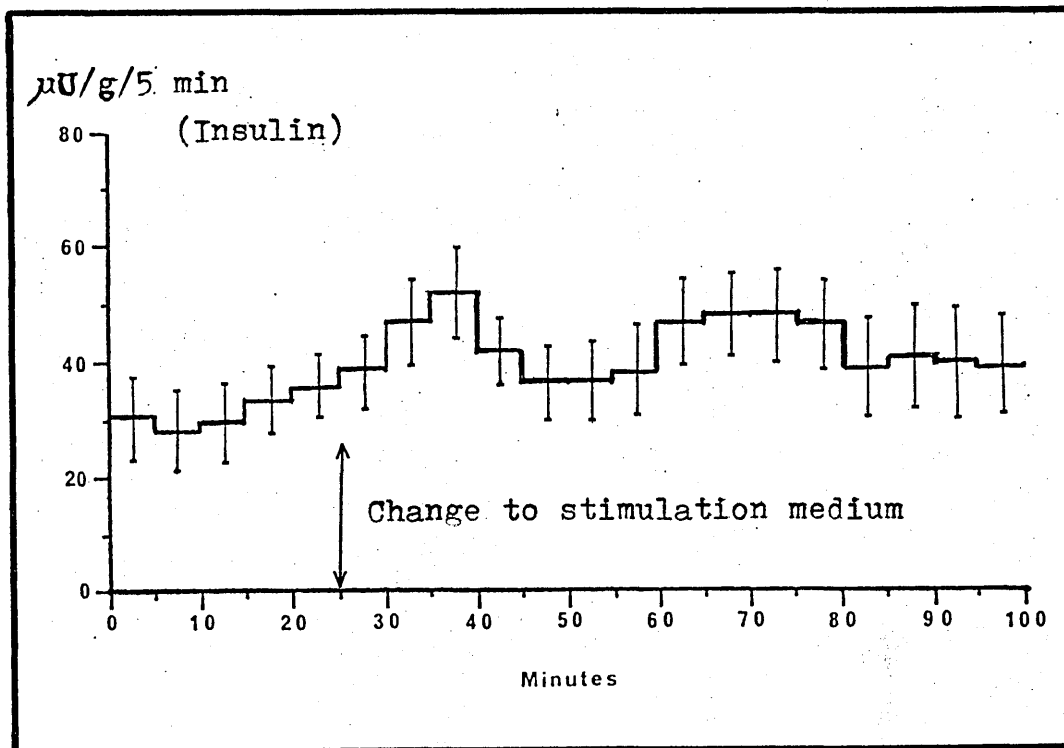

Figure 8. Effect of noradrenaline (100 ng/100 ml) and phentolamine (50  $\mu$ g/100 ml) on basal and glucose-stimulated insulin secretion rates in the cold-acclimated rat pancreas. Values are the means of six samples, and the vertical bars represent the standard errors of the means in each case.

VII. Insulin secretion after phentolamine treatment during the last week of cold-acclimation of rats

Results are summarized in Table (5) and Fig. (9). The pancreases of six rats with an average body weight of  $301.67 \pm 5.33$  g, were isolated and perfused for this set of experiments. The average wet weight of the pancreases was  $0.671 \pm 0.041$  g. The average perfusion rate was  $1.51 \pm 0.03$  ml/5 min. and the perfusion pressure ranged between 82 and 95 mm Hg. Glucose concentrations in the basal medium and in the stimulation medium were  $4.485$  mmol/l and  $16.94$  mmol/l respectively.

The basal rate of insulin release ranged between  $34.07 \pm 3.13$   $\mu$ U/g/5 min. and  $43.43 \pm 8.30$   $\mu$ U/g/5 min. In response to glucose stimulation, the insulin release followed the general biphasic pattern: the first phase of release peaked at  $72.18 \pm 10.04$   $\mu$ U/g/5 min. The second phase ranged between  $59.52 \pm 9.79$  and  $84.62 \pm 7.50$   $\mu$ U/g/5 min. The differences between the values of both phases of insulin release and the range of the basal rate of insulin release are all highly significant ( $p < 0.001$ ). Insulin released in the first phase was about 9.3% of that released during the second phase for fifty minutes.

Glucose uptake by the block of perfused tissue was calculated to be  $4.626 \times 10^{-3}$  mmol/g/hour from the basal perfusion medium and  $2.475 \times 10^{-2}$  mmol/g/hour from the stimulation medium.

Table 5: Data obtained from outflow of perfused pancreases  
of cold-acclimated rats treated with phentolamine during  
the last week of cold-acclimation

Sample	Volume ml	Glucose concentration mmol/l	Insulin concentration $\mu$ U/ml	Insulin secretion rate $\mu$ U/g/5 min.
1	1.63 $\pm$ 0.19	3.82 $\pm$ 0.11	16.13 $\pm$ 3.09	34.07 $\pm$ 3.13
2	1.61 $\pm$ 0.18	3.80 $\pm$ 0.11	18.23 $\pm$ 5.25	37.17 $\pm$ 7.05
3	1.55 $\pm$ 0.20	3.81 $\pm$ 0.11	20.70 $\pm$ 6.46	41.08 $\pm$ 8.74
4	1.55 $\pm$ 0.19	3.79 $\pm$ 0.10	19.83 $\pm$ 5.74	39.20 $\pm$ 7.75
5	1.55 $\pm$ 0.20	3.85 $\pm$ 0.11	21.77 $\pm$ 6.10	43.43 $\pm$ 8.30
6	1.61 $\pm$ 0.19	7.08 $\pm$ 0.58	24.77 $\pm$ 6.04	51.52 $\pm$ 8.97
7	1.55 $\pm$ 0.18	12.09 $\pm$ 0.53	28.13 $\pm$ 7.54	57.45 $\pm$ 11.16
8	1.55 $\pm$ 0.17	13.21 $\pm$ 0.28	35.43 $\pm$ 7.91	72.18 $\pm$ 10.04
9	1.54 $\pm$ 0.17	13.96 $\pm$ 0.22	25.75 $\pm$ 5.20	53.62 $\pm$ 6.59
10	1.51 $\pm$ 0.18	13.98 $\pm$ 0.20	30.35 $\pm$ 7.13	59.52 $\pm$ 9.79
11	1.50 $\pm$ 0.19	13.99 $\pm$ 0.16	31.97 $\pm$ 7.30	61.15 $\pm$ 9.75
12	1.51 $\pm$ 0.18	14.32 $\pm$ 0.31	35.83 $\pm$ 7.27	71.37 $\pm$ 9.03
13	1.42 $\pm$ 0.12	14.12 $\pm$ 0.17	34.62 $\pm$ 6.01	68.23 $\pm$ 7.38
14	1.43 $\pm$ 0.11	14.20 $\pm$ 0.20	39.57 $\pm$ 6.22	79.25 $\pm$ 9.11
15	1.43 $\pm$ 0.12	14.38 $\pm$ 0.23	39.68 $\pm$ 6.69	79.03 $\pm$ 8.74
16	1.43 $\pm$ 0.11	14.36 $\pm$ 0.21	42.02 $\pm$ 7.07	94.23 $\pm$ 7.79
17	1.46 $\pm$ 0.11	14.14 $\pm$ 0.15	40.20 $\pm$ 5.07	84.62 $\pm$ 7.50
18	1.48 $\pm$ 0.11	14.42 $\pm$ 0.24	39.55 $\pm$ 6.20	82.48 $\pm$ 7.39
19	1.45 $\pm$ 0.11	14.23 $\pm$ 0.17	39.12 $\pm$ 5.04	82.15 $\pm$ 7.20
20	1.47 $\pm$ 0.11	14.15 $\pm$ 0.14	39.40 $\pm$ 5.21	83.37 $\pm$ 7.26

- i) In all cases, n = 6
- ii) Mean body weight of animals = 301.67  $\pm$  5.33 g
- iii) Mean wet weight of pancreas = 0.671  $\pm$  0.041 g
- iv) All values are expressed as the mean and the standard error of the mean.

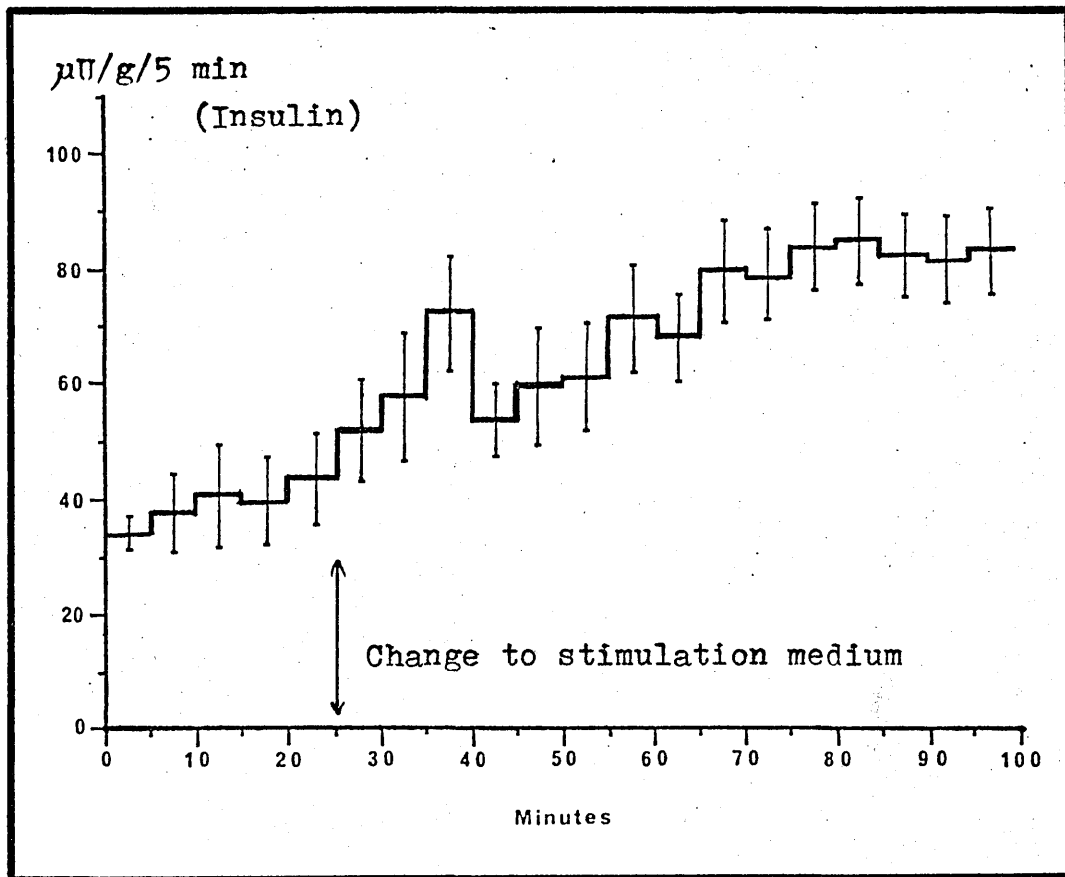

Figure 9. Effect of phentolamine treatment during the last week of cold-acclimation on the basal and the glucose-stimulated insulin secretion rates. Values are the mean of six samples and the vertical bars represent the standard errors of the means in each case.

VIII. Insulin secretion after bilateral adrenal demedullation of rats at the beginning of the last week of cold-acclimation

Results are summarized in Table (6) and Fig. (10). Six rats with an average body weight of  $301.08 \pm 4.38$  g were used in this set of experiments. Mortality rate after bilateral adrenal demedullation was 8.3%. The average wet weights of the perfused pancreases was  $0.839 \pm 0.014$  g. The average perfusion rate was  $2.127 \pm 0.009$  ml/5 min. and the perfusion pressure ranged between 85 and 94 mm Hg. Glucose concentrations in the basal medium and in the stimulation medium were 4.135 mmol/l and 16.425 mmol/l respectively.

The basal rate of insulin release ranged between  $14.92 \pm 0.77$  and  $21.78 \pm 2.98$   $\mu\text{U/g/5 min}$ . Insulin release in response to glucose stimulation after the shift into the stimulation medium perfusion exhibited the previously described biphasic pattern: the first phase of insulin release peaked at  $41.72 \pm 2.79$   $\mu\text{U/g/5 min}$ ; the second phase of the biphasic response ranged between  $25.05 \pm 6.38$  and  $37.77 \pm 5.67$   $\mu\text{U/g/5 min}$ . Both phases of insulin release had their values significantly higher than those of the basal secretion rate ( $p < 0.001$ ). Insulin released in the first phase was 13.3% of that released during the second phase for fifty minutes.

Glucose uptake by the block of perfused tissue was  $7.210 \times 10^{-3}$  mmol/g/hour from the basal medium and  $3.531 \times 10^{-2}$  mmol/g/hour from the stimulation medium.

Table 6: Data obtained from outflow of perfused pancreases of cold-acclimated rats subjected to bilateral adrenal demedullation performed at the beginning of the last week of cold-acclimation

Sample	Volume ml	Glucose concentration mmol/l	Insulin concentration $\mu$ U/ml	Insulin secretion rate $\mu$ U/g/5 min.
1	2.16 $\pm$ 0.09	3.57 $\pm$ 0.13	8.28 $\pm$ 0.99	21.78 $\pm$ 2.98
2	2.15 $\pm$ 0.11	3.56 $\pm$ 0.13	7.97 $\pm$ 0.78	20.72 $\pm$ 2.31
3	2.14 $\pm$ 0.10	3.60 $\pm$ 0.14	5.80 $\pm$ 0.23	14.92 $\pm$ 0.77
4	2.10 $\pm$ 0.09	3.55 $\pm$ 0.12	7.40 $\pm$ 0.73	18.52 $\pm$ 1.59
5	2.12 $\pm$ 0.09	3.57 $\pm$ 0.13	6.82 $\pm$ 0.73	17.17 $\pm$ 1.27
6	2.16 $\pm$ 0.13	6.57 $\pm$ 0.33	10.62 $\pm$ 1.27	27.92 $\pm$ 4.16
7	2.14 $\pm$ 0.13	10.70 $\pm$ 0.45	16.17 $\pm$ 0.57	41.72 $\pm$ 2.79
8	2.12 $\pm$ 0.13	12.92 $\pm$ 0.19	14.25 $\pm$ 2.21	36.68 $\pm$ 6.71
9	2.11 $\pm$ 0.13	13.37 $\pm$ 0.18	11.82 $\pm$ 3.02	30.87 $\pm$ 8.82
10	2.09 $\pm$ 0.13	13.38 $\pm$ 0.15	9.18 $\pm$ 1.60	23.82 $\pm$ 4.96
11	2.11 $\pm$ 0.14	13.58 $\pm$ 0.20	9.62 $\pm$ 2.23	25.05 $\pm$ 6.38
12	2.12 $\pm$ 0.15	13.78 $\pm$ 0.27	10.22 $\pm$ 2.44	26.53 $\pm$ 6.92
13	2.12 $\pm$ 0.16	13.81 $\pm$ 0.24	11.38 $\pm$ 2.07	29.82 $\pm$ 6.19
14	2.13 $\pm$ 0.16	13.63 $\pm$ 0.17	11.48 $\pm$ 1.84	29.85 $\pm$ 5.55
15	2.13 $\pm$ 0.17	13.72 $\pm$ 0.18	12.98 $\pm$ 1.82	33.62 $\pm$ 5.76
16	2.13 $\pm$ 0.18	13.70 $\pm$ 0.18	13.12 $\pm$ 1.25	33.97 $\pm$ 4.83
17	2.17 $\pm$ 0.21	13.74 $\pm$ 0.16	14.30 $\pm$ 1.44	37.77 $\pm$ 5.67
18	2.13 $\pm$ 0.18	13.62 $\pm$ 0.16	12.58 $\pm$ 1.70	32.27 $\pm$ 5.56
19	2.10 $\pm$ 0.17	13.63 $\pm$ 0.15	12.32 $\pm$ 1.43	30.92 $\pm$ 4.45
20	2.11 $\pm$ 0.18	13.65 $\pm$ 0.14	13.22 $\pm$ 1.57	33.93 $\pm$ 5.70

- i) In all cases, n = 6
- ii) Mean body weight of animals = 301.08  $\pm$  4.38 g
- iii) Mean wet weight of pancreas = 0.830  $\pm$  0.014 g
- iv) All values are expressed as the mean and the standard error of the mean.

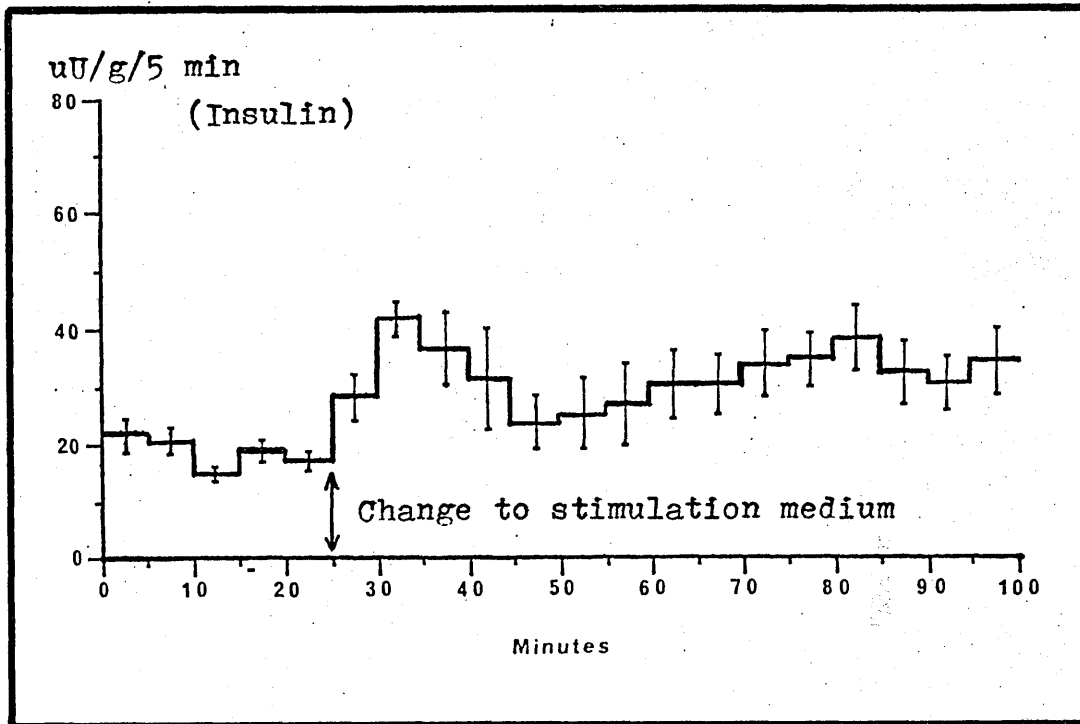

Figure 10. Effect of bilateral adrenal demedullation at the beginning of the last week of cold-acclimation on the basal and the glucose-stimulated insulin secretion rates. Values are the means of six samples and the vertical lines represent the standard errors of the mean in each case.



90

Comparative light microscopic examination of sections of the normal adrenals and the demedullated adrenals were made and these showed complete removal of the medullary tissue in all the animals of the latter group. Photographs of a typical example of each group are shown in Fig. (11).

IX. Summary of the statistical analyses of the results

Results of insulin secretion rates of the five different sets of experiments are summarized in Fig. (12), where point-to-point comparisons were made with the assistance of (t) values of the student t-test for matched paired samples, two-tailed test.

All values of insulin secretion rates before and during glucose stimulation in the main control set (MC) are significantly higher than all insulin secretion rates of the cold-acclimated (CA), the cold-acclimated with noradrenaline and phentolamine perfusion (CANP) and the cold-acclimated with adrenal demedullation (CADM) sets (all:  $p < 0.001$ ); the insulin secretion rates of (MC) are significantly higher than insulin secretion rates of the cold-acclimated-phentolamine treated (CAPT) set ( $p < 0.01$ ).

Values of insulin secretion rates before and during glucose stimulation in the (CA) set are not significantly different from values of insulin secretion rates in (CANP) and (CADM) sets. But those same values of (CA) set, when compared with insulin secretion rates in the (CAPT) set, the level of difference prior to glucose stimulation is not significant, while during glucose stimulation,

values of insulin secretion rate in the (CAPT) set are significantly different (higher) from those of the (CA) set ( $p < 0.02$ ).

Values of insulin secretion rates in the (CAPT) set are significantly different (higher) from values of insulin secretion rates in the (CADM) set, prior to glucose stimulation ( $p < 0.05$ ), and during glucose stimulation ( $p < 0.02$ ).

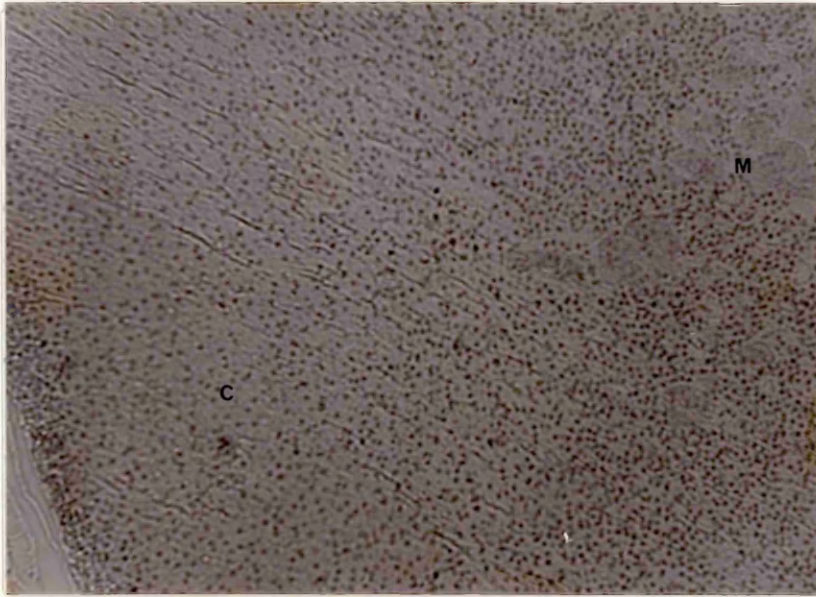

(a)

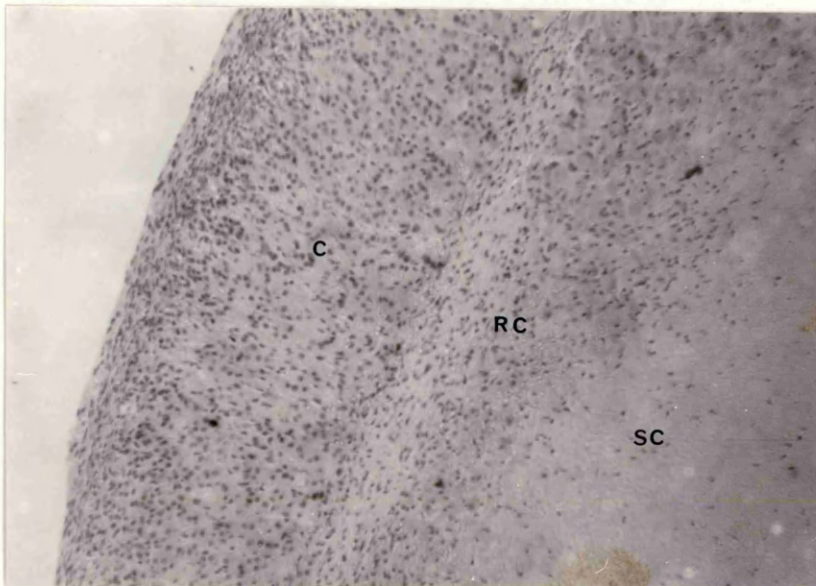

(b)

Figure 11. Photomicrograph of adrenal gland (a) and demedullated adrenal gland (b) of the rat. Stained haematoxyline eosine, 100X. Key to labels: (c) cortical cells, (M) medullary cells, (RC) regenerating cortical cells, (SC) fibrous scar tissue.

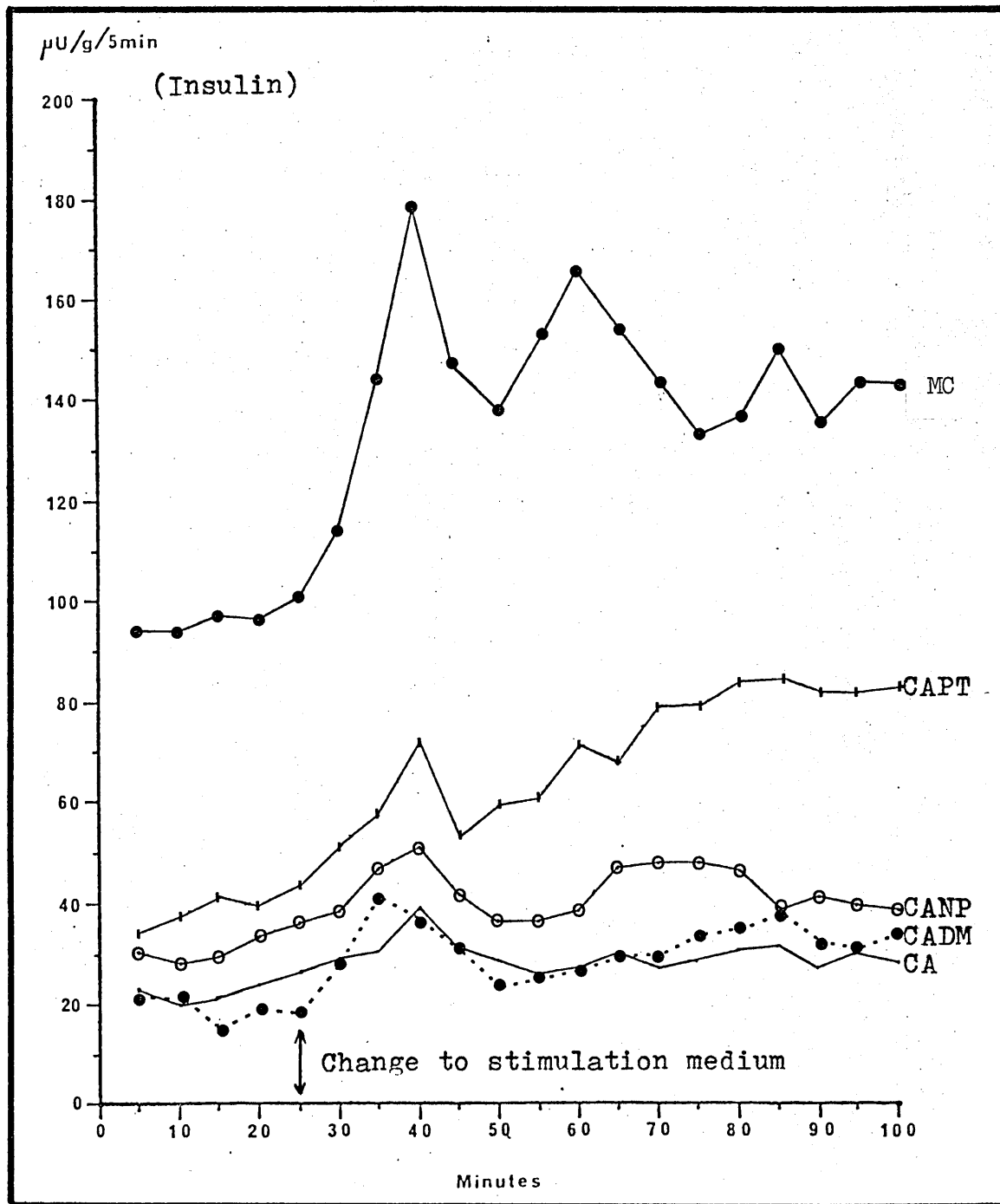

Figure 12. Comparative summary of basal and glucose stimulated insulin secretion rates of the main control and the experimental sets of rats: (MC) main control; (CAPT) cold-acclimated-phenolamine treated; (CANP) cold-acclimated, noradrenaline and phenolamine infused; (CADM) cold-acclimated, bilateral adrenal demedullated; (CA) cold-acclimated.

94

## DISCUSSION

### I. General observations

The physiology of cold exposure and cold-acclimation has become a subject of great importance. It has been shown that cold-acclimation alters basic metabolic interactions which involve heat energy exchanges in the body of homeotherms. An effect of cold-acclimation on the normal secretion range and pattern of insulin from pancreatic islets has been proposed for this investigation. Cold, as a stimulus, has been shown to increase plasma noradrenaline content (Benedict, Fillenz and Stanford, 1977 a; DesMarais and Dugal, 1951; Euler, 1971; Himms-Hagen, 1972; LeBlanc and Nadeau, 1961; Nathanielsz, 1969; Sellers, Flattery, Shum and Johnson, 1971; Shum, Johnson and Flattery 1969). Furthermore, it has been demonstrated that an increase in catecholamine levels may inhibit net or overall insulin secretion from the pancreatic islets (Buse et al., 1970; Cerasi et al., 1969; Malaisse et al., 1967 b; Yajima et al., 1977).

From the results of the present investigations it is possible to make certain general observations with respect to the effect of cold-acclimation on insulin secretion from the beta-cells of the islets of Langerhans of the pancreas, as well as, the regulatory influence of alpha-adrenergic receptors and sympathomimetics on insulin secretion:

1. Insulin secretion, from the isolated perfused pancreas, in response to a glucose stimulus exhibits a biphasic secretion pattern which is considered to involve storage compartments of insulin in the beta-cells of the pancreatic islets.
2. Cold-acclimation reduces insulin secretion in the rat. This reduction might be a partial inhibition of insulin release in response to glucose stimulation and/or a suppression of insulin synthesis in the beta-cells.
3. Insulin release from the isolated perfused pancreas is inhibited by the perfusion of high doses of noradrenaline.
4. The reduction of insulin secretion is an alpha-adrenergic effect which is reversed by the action of the alpha-adrenergic antagonist, phentolamine.
5. The regulatory effect of the alpha-adrenergic terminals in the beta-cells of the pancreatic islets is controlled directly by the sympathetic postganglionic fibres rather than by adrenal medullary secretion of catecholamines.

## II. Discussion of the general observations

### 1. The secretory dynamics of insulin:

The insulin secretion response to glucose stimulation indicates that the insulin release is multiphasic. As the

70

glucose concentration of the perfusing medium reaching the beta-cells is suddenly raised and kept at a high level (16 mmol/l), the secretory response of these cells exhibits a biphasic release of insulin. The same observation has been reported by many workers (Basake et al., 1971; Curry et al., 1968 a; Curry, 1971; Fussganger et al., 1969; Grodsky et al., 1963, 1970; Grodsky, Bennett, Smith and Schmid, 1967; Hellerstrom, Andersson, Gummarsson and Bern, 1974; Loubatières et al., 1970 a; Loubatières-Mariani et al., 1973). Some evidence of a biphasic response to glucose in vivo in man has been obtained by Cerasi and Luft (1967), who measured insulin concentration in plasma after administration of an intravenous glucose load.

In the present study, a peak of insulin release ( $179.44 \pm 8.57 \mu\text{U/g/5 min.}$ ) denoting the first phase, was observed after the change to perfusion with the stimulatory glucose load. This first phase Fig. (5) was followed by a low, but higher than basal ( $94.34 \pm 14.16 \mu\text{U/g/5 min.}$ ) insulin output. The second phase of insulin release was manifested as an overall increase in the rate of insulin release and ranged between 133.99 and  $166.43 \mu\text{U/g/5 min.}$  This relatively high rate of hormone release was maintained for as long as the glucose load is present and within the time limit of the experiment.

The glucose load stimulus was intended to be a sharp square wave of increase, but after glucose content analyses of the collected samples it was shown that the total rise in glucose concentration continued for a period of five to ten minutes.

This was because after the shift into the stimulation perfusion medium, the high glucose concentration underwent some dilution with the volume of the normal perfusion medium already filling the main perfusing head, the arterial cannula and the trunk of the coeliac axis. Thus, insulin release in the first phase was gradual for a short time but eventually reached the peak within five minutes once the glucose load was 8.325 mmol/l (150 mg/100 ml) or more. Curry (1971) showed a comparable effect on insulin release in response to a slow-rising glucose stimulus (30-300 mg/100 ml; duration 82 minutes) in the isolated perfused rat pancreas.

The multiphasic insulin secretion pattern probably indicates the existence of two pools of insulin (Curry et al., 1968 a,b; Grodsky et al., 1968; Porte and Pupo, 1969). Grodsky et al. (1970) have proposed a two-compartment model to account for the biphasic pattern of insulin release in response to glucose or tolbutamide stimulation. The essential feature of the model is the suggestion that only a small proportion (or compartment) that is, 2%, of pancreatic insulin is available for rapid release and that the remainder (the larger) compartment is released at a much slower rate. The initial rapid response lasts for some five minutes and is superimposed on a more protracted rise in the rate of insulin release over sixty minutes of perfusion. In the results presented here, the total amount of insulin released in the first phase was calculated to be about 10% of that released during the second phase over a period of fifty minutes. However, if the suggested superimposed initial rapid response of insulin release (which lasts for some five



minutes) is taken into consideration, then the net value of insulin released as such is calculated to be 1.8% of that released during the second prolonged phase.

The significance of the first phase of insulin release is obscure since it can be stimulated, in the absence of glucose, by sudden changes of concentrations of solutes in the perfusion medium, and that this first phase does not occur in response to a very slowly rising stimulus (glucose or otherwise) (Curry, 1971). Thus this first pool or compartment of insulin could serve as a safeguard against sudden increases in glucose concentration and it probably functions without a discriminatory mechanism for glucose.

The second phase of insulin release is glucose dependent and it could involve a second pool or compartment but it has not yet been ascertained whether the beta-cell receptors react primarily to the total amount of glucose which is presented, to the rate of change in plasma glucose or to a combination thereof (Curry, 1971). Nevertheless, there is a specific mechanism which results with insulin secretion being stimulated by a metabolite (Gagliandino, 1966) or possibly a product resulting from the metabolism of glucose which can also be supplied by other metabolizable sugars (Grodsky et al., 1963).

Glucose seems to stimulate insulin synthesis which is released in response to prolonged glucose stimulation during the second phase. In a set of four isolated perfused pancreas experiments (the results of which are not reported here) streptomycin and penicillin were included in the perfusion media at a final concentration of 100 U/ml each.

99

This resulted in a partial reduction of insulin release in response to glucose stimulation throughout the second phase of release, with no significant change in the first phase. This could be interpreted as the result of inhibition of insulin synthesis by the protein synthesis inhibitor streptomycin and thus it could be concluded that the second pool or compartment of insulin involves newly synthesised insulin as well as prestored insulin, in contrast to the first pool or compartment which stores insulin for immediate release. Gotfredsen (1976) included penicillin and streptomycin (100 U/ml each) in the perfusion media of the isolated perfused pancreas, but did not comment on the use of those antibiotics especially in relation to the second phase of insulin release. Curry et al. (1968 b) showed that puromycin had no apparent effect on the first phase but there was a reduced output of insulin in the second phase in response to glucose stimulation.

Glucose uptake by the perfused block of tissues was observed to be in direct proportion to glucose concentration perfusing the tissues. From the results of glucose uptake in this set of experiments, the average amount of glucose taken up by the tissues from the high glucose concentration media is 5.5 times that taken up from the normal low glucose concentration media. These results are in agreement with those of Snyder et al. (1970) who reported that glucose uptake from 16.65 mmol/l glucose medium was 4.8 times more than the uptake from 3.33 mmol/l glucose medium by isolated rat islets.

This increased value of glucose uptake correlates with the increased insulin release rate of the second phase, but it is not certain whether this glucose is completely metabolised before exerting its action as a stimulant for insulin release and synthesis. Nor is it certain what proportion is responsible for which mechanism. Furthermore, in the present study, the glucose uptake values, together with arterio-venous oxygen tension differences, served as reliable indicators of the viability of the isolated perfused pancreas.

The precise sequence of events leading to the release of insulin by the pancreatic beta-cell in response to glucose stimulation remains an open question for further investigation.

## 2. Effect of cold-acclimation on insulin secretion

The insulin secretory response to glucose stimulation in the isolate perfused pancreas of the cold-acclimated rat, showed a very significant total reduction of insulin release in comparison with the normal controls ( $p < 0.001$ ) at all points. The biphasic secretion pattern was still evident, Fig. (6). The basal insulin secretion rate was about 23.3% of that in the normal; the peak of the first phase in response to glucose stimulation was about 21.5% of the normal and the range of the second phase of release was comparably reduced. There are a number of possible reasons for the total reduction in insulin release in response to cold stress. It could be either the result of reduced sensitivity of the beta-cell to glucose stimulation or an overall reduction of compartment

size of both pools of insulin in the beta-cell, which, in other words, might mean a reduction in insulin synthesis.

Beck et al., (1967), Howland (1967) and Howland and Nowell (1968) demonstrated that rats exposed for (2-7) weeks to severe cold exhibited a significant decrease in serum immuno-assayable insulin levels. The fact that basal insulin release rate is reduced after cold-acclimation, supports the contention that there is an overall reduction of stored insulin and thus, a reduction in insulin synthesis. This total insulin reduction is accompanied by an increased insulin sensitivity in the cold-acclimated rat (Mansour and Hewitt, 1954; Depocas, 1961; Howland, 1967; Smith, 1962), and a decrease in pancreatic-extractable insulin (Baker and Ashworth, 1958) as well as, a reduction in the availability of insulin at the various centres of metabolic activity (Himms-Hagen, 1972). However, these observations do not rule out the possibility of a reduced response of the beta-cells to glucose stimulation which involves a very complicated mechanism influenced by many factors identified and characterized in terms of inhibition or enhancement of this glucose-induced insulin release. Little is known of their precise site of action in the beta-cell. It has been proposed that there are glucoreceptors, on the beta-cell, which involve two sites of mechanism: a substrate site and a regulatory site (Randle, Ashcroft and Gill, 1968). As

mentioned previously, the insulin secretory response to glucose is biphasic, but it is not clear whether the same glucoreceptor mechanism is involved in the two phases of the secretory response. The suggestion for the operation of the substrate site mechanism comes from the observation that sugars readily metabolized by mammalian tissues (e.g. glucose, mannose, and fructose) elicit insulin release, while non metabolizable sugars (e.g. galactose) do not stimulate release of insulin (Coore and Randle, 1964 a,b; Grodsky et al., 1963). The regulator site mechanism is still very hypothetical and needs further studies to establish the mechanism of this effect and its potential for a glucoreceptor mechanism.

During cold-acclimation the main reaction of many animals (including the rat) is a greatly increased secretion of noradrenaline (and adrenaline), as shown by many investigators (Basake et al., 1971; Benedict et al., 1977 a; Leduc, 1961 a,b; Nathanielsz, 1969; Roy, Sellers, Flattery and Sellers, 1977; Sellers et al., 1971; Shum et al., 1969). This enhanced secretion of catecholamines is of great importance in relation to insulin secretory mechanisms of the beta-cells of the pancreas, as well as in the overall process of cold-acclimation.

Having demonstrated that high noradrenaline concentrations inhibit insulin release in response to glucose stimulation (discussed in the next section) which is in accordance with the work of Porte and Pupo (1969), it might

be proposed that the reduction of insulin secretion after cold-acclimation is due to the inhibitory effect of nor-adrenaline released in response to the cold stress and that this inhibition is acting on one or both effector mechanisms of insulin secretion and synthesis. The mechanism of inhibition of the insulin release as seen in this investigation will therefore involve the alpha-adrenergic receptors of the pancreatic beta-cells. Although it seems probable that this action involves the inhibition of adenosine triphosphate (ATP) formation (Malaisse and Malaisse-Lagae, 1970 a), there could be an additional inhibitory effect on calcium ion uptake which is suspected by Hales and Milner (1968) and Hales (1970) to play an important role in the process of insulin release. The sites of action of other inhibitions may be glucose phosphorylation, calcium ion flux and ATP formation, all of which are more or less related to both mechanisms of insulin synthesis and release.

Although the synthesis of noradrenaline rises at the beginning of the development of the cold-acclimation up to four times the normal, a gradual decline takes place over several weeks to a level about double the precold-exposure value (Leduc, 1961 b; Sellers et al., 1971; Shum et al., 1969). Nevertheless, the inhibitory influence on insulin release is observed to be still effective after six or more weeks of cold exposure, although a reduced sensitivity to nor-adrenaline is reported to be prevailing by that time (Raff, 1976).

The fact that noradrenaline suppresses insulin secretion (and possibly synthesis) is very noteworthy since this catecholamine, which is released from sympathetic nerve endings, lying in close proximity to beta-cells of the pancreatic islets (Lacy, 1957, 1967; Shorr and Bloom, 1970), may be of greater significance in modulating insulin release during the cold stress, than is adrenaline which originates primarily from the adrenal medulla and which was shown by many investigators to increase during cold-acclimation as well (Depocas, 1960 a; Hammond and Hammolsky, 1970; Leduc, 1961 a,b; Malaisse et al., 1967 b; Smith, 1962). It is therefore, very probable that the influences of noradrenaline (directly and indirectly) and adrenaline (indirectly) make cold-acclimation possible in the presence of an insulin deficiency, together with other metabolic changes and mechanisms, such as increased mobilisation of free fatty acids, reduced dependence on glucose as the main metabolite and the involvement of new thermogenic centres such as brown adipose tissue. The increased lipolysis in white fat, where less inhibition of triglyceride lipase helps the process of triglyceride hydrolysis and thus mobilization, all of which require the presence of higher levels of catecholamines. It has been demonstrated that some of the diabetic rats undergoing prolonged cold exposure, do survive and exhibit

certain criteria of cold-acclimation (Poe, White, and Davis, 1963), indicating that at least a "normal" amount of insulin is not an absolute necessity for cold-acclimation and suggesting that some compensatory mechanism might be involved.

This altered steady state, achieved after cold-acclimation in rats, which is characterised by increased secretion of catecholamines and reduced availability and secretion of insulin is very much similar to conditions prevailing during exercise where there is suppression of insulin secretion (Ahlborg, Felig, Hagenfeldt, Hendler and Wahren, 1974; Ahrens, Bishop and Berdanier, 1972; Berdanier and Moser, 1972; Harvey, Faloon and Unger, 1974; Wright and Malaisse, 1968) as well as enhancement of catecholamine secretion (Chin and Evonuk, 1971; Galbo, Holst and Christensen, 1971; Haggendal, Hartley and Saltin, 1970; Yajima et al., 1977). Both these effects contribute in the mobilization and increase of glucose and free fatty acids which are needed during exercise and also, comparably, during cold stress.

3. Effect of noradrenaline perfusion on insulin secretion

The perfusion of noradrenaline into the isolated perfused rat pancreas resulted in an inhibition of insulin secretion in response to glucose stimulation. This inhibition is dose-dependent.



At low concentrations of noradrenaline, ranging between (5 ng and 40 ng) per 100 ml of perfusion medium the biphasic secretion pattern of insulin persisted, although the insulin secretion rate fell with the increase of noradrenaline concentration. At (80 ng and 100 ng) per 100 ml perfusion medium, the basal insulin secretion rate was the same and constant Fig. (7), but the first phase of insulin release in response to glucose stimulation was completely abolished, which indicates that inhibition of the first phase is an alpha-adrenergic phenomenon. Furthermore, the second phase of insulin release showed an overall reduction in comparison with the control group ( $p < 0.001$ ), but it exhibited a slight increase over the basal secretion rate prior to glucose stimulation ( $p < 0.05$ ), which might indicate a dual effect of alpha-adrenergic inhibition and a probable second mechanism which over-rides the total inhibitory influence of noradrenaline.

It is well established that the adrenergic receptors of the beta-cell of the pancreatic islets play an important role in the regulation of insulin secretion, and it is accepted that the activation of the alpha-adrenergic receptors result in an inhibition of this secretion (Loubatières et al., 1967, 1970 a; Loubatières and Loubatières-Mariani, 1974; Malaisse et al., 1967 b; Porte, 1967 a, 1969; Porte et al., 1966; Sumi and Ui, 1975).

Porte and Williams (1966) demonstrated that noradrenaline has an inhibitory action upon glucose stimulated insulin secretion although it is considerably weaker in this action than is adrenaline. This difference in the degree of inhibition produced, may be due to the varying potency of these two catecholamines as alpha-adrenergic receptor stimulators (Day, 1975). Nevertheless, the perfusion of noradrenaline resulted in an inhibition of insulin release from the isolated perfused pancreas of normal rats which approached that inhibited level produced by the effect of cold-acclimation on rats. However, the main difference between the two situations is the presence of a first phase of insulin release in response to glucose stimulation in the isolated perfused pancreas of the cold-acclimated rat, whereas this first phase was abolished by the perfusion of high doses of noradrenaline in the presence of glucose load. This indicates a difference between the direct effect of exogenous noradrenaline on alpha-adrenergic receptors of the pancreatic beta-cells of normal rats and the effect resulting from gradual change during the process of cold-acclimation. During acclimation, noradrenaline secretion increases at the onset of the cold stress and subsides later but remains higher than the normal.

In the set of experiments with the isolated perfused pancreas (after cold-acclimation) where both the basal and the stimulatory perfusates included, simultaneously, noradrenaline and phentolamine (the alpha-adrenergic antagonist), the results

show that the pattern and amounts of insulin secretion rates, compared with those of the cold-acclimated set, exhibited no significant differences ( $p \geq 0.5$ ). These results indicate that there exists a distinct gradual change of mechanism relating the regulatory effect of adrenergic receptors with the net process of insulin secretion from the beta-cells during the process of cold-acclimation.

Malaisse et al., (1967 b) demonstrated that adrenaline and noradrenaline inhibit insulin secretion from pieces of rat pancreas incubated with glucose 8.325 mmol/l, and suggested that this inhibitory effect is mediated through alpha-receptors for it is blocked by alpha- but little affected by beta- blocking agents. The same inhibitory effect was demonstrated in man (Porte et al., 1966), in dog (Porte, Girardier, Seydoux, Kanazawa and Posternak, 1973), in rat (Loubatières-Mariani, Chapal, Ribes and Loubatières, 1977), and in rabbit (Coore and Randle, 1964).

Buse et al., (1970) reported that endogenous catecholamines have an inhibitory action upon glucose induced insulin secretion in man; yet in many patients with elevated plasma levels of catecholamines (Vance, Buchanan, O'Hara, Williams and Porte, 1969) and in those in metabolic stress states in which catecholamine levels may be expected to be increased, basal insulin concentrations are either normal or increased. The explanation for this finding is probably

related to the remark that long-term steady state responses to glucose are not inhibited by adrenaline and noradrenaline. Such observations and studies support the previous suggestion that basal insulin concentrations are secreted from a pool that is functionally distinct from the storage pool(s) for glucose stimulated insulin responses.

Finally, there exist some discrepancies in the response of beta-cells to their activation by different adrenergic stimulating agents, observed not only between the different animal species but also within the same species (Loubatières-Mariani et al., 1977), depending on the age of the animals under experiment. Thus all experimental animals in this investigation were chosen from the same age group in order to eliminate such inconsistencies. Similarly, each whole set of experiments was performed during a period of ten to fifteen days in order to avoid any possibility of effect of seasonal variation on noradrenaline plasma levels, or to noradrenaline sensitivity (Leduc, 1961 a,b).

#### 4. Effect of phentolamine treatment during cold-acclimation

Treatment of the rats during the last week of cold-acclimation with subcutaneous injections of phentolamine (the alpha-adrenergic antagonist) resulted in a pronounced elevation of insulin secretion compared with that of the

cold-acclimated set, in response to glucose stimulation, ( $p < 0.02$ ). But, this increase did not restore the insulin secretion rates up to the values of the normal control set.

The basal insulin secretion rates after phentolamine treatment are not statistically different from the basal rates of insulin release exhibited in the cold-acclimated set and this indicates that basal insulin, although reduced after cold-acclimation, is not strictly modulated by endogenous catecholamines. Thus it is not influenced by the alpha-adrenergic action of phentolamine on catecholamines and in particular noradrenaline, which supposedly inhibits insulin secretion as a result of cold-acclimation. It is therefore suspected that there exists a distinct mechanism that regulates basal insulin release (and possibly synthesis), and that it might involve a different storage pool of insulin in the beta-cells. Such a finding supports the same hypothesis of the existence of insulin storage pools discussed earlier (Grotsky, 1972 a,b; Porte and Pupo, 1969).

In response to glucose stimulation, the pattern of insulin release in this set of experiments is biphasic, Fig. (9). The first phase peak is significantly greater than that of the cold-acclimated set ( $p < 0.02$ ), and at the same time it is significantly less than the peak value of the first phase of the normal control set ( $p < 0.001$ ). Similarly, the second phase of insulin release has all its values significantly

111

higher than those of the second phase values of the cold-acclimated set ( $p < 0.01$ ) and at the same time they are significantly lower than those of the normal control group ( $p < 0.01$ ).

From these results, and in view of the report by Malaisse et al., (1967 b) and Porte (1967 b), it is evident that phentolamine blocked the inhibitory effect of nor-adrenaline upon insulin secretion in response to glucose stimulation. Similar actions of alpha-adrenergic blockers during exercise are reported by Harvey et al. (1974). These results support the hypothesis that insulin release in response to glucose stimulation involves pools or compartments different from those involved in the basal release of insulin. Porte (1969) demonstrated that alpha-adrenergic blocking agents can suppress the inhibitory effect of endogenously secreted catecholamines and thus Bressler et al., (1968) and Buse et al., (1970) suggested that it may seem logical that in vivo the alpha-adrenergic blocking agents tend to increase the basal or the glucose-stimulated levels of circulating insulin. Buse et al. (1970) showed that pre-treatment of normal subjects with phentolamine resulted in a significantly greater insulin response in comparison with controls, the mean plasma insulin levels being 38% greater in the experimental group, five minutes after glucose injection. Despite this greater insulin response, the blood glucose levels were similar in these two groups suggesting that counter-regulatory mechanisms may have been brought into action by the increased insulin release during alpha-blockade.

112

Adrenaline retains its glycogenolytic actions during alpha-blockade (Porte, 1967 a) and may also stimulate glucagon secretion (Gerish, Karam and Forsham, 1973; Gerish, Langlois, Noacco, Schneider and Forsham, 1974).

Such studies as well as the work by Robertson and Porte (1974) support the conclusion that endogenous catecholamines modulate the insulin secretory response to glucose stimulation. Similarly, Potter et al., (1977) reported that alpha-adrenergic agonists inhibit insulin release, a finding which agrees with the above mentioned studies that demonstrated phentolamine to be without effect on basal insulin levels when given alone, suggesting that basal insulin secretion is not modulated by endogenous alpha-adrenergic activity. This is also in agreement with the results of the present investigation, where exogenous alpha-adrenergic blockade did not have an effect on basal insulin secretion. Furthermore, Efendic, Cerasi and Luft (1973) and Imura, Kato, Ikeda, Morimoto and Yawata (1971) found no effect of phentolamine upon basal insulin levels. Udenfriend (1968) reported that alpha-adrenergic blockage resulted in more catecholamines being synthesized in sympathetically innervated tissues than during exercise or exposure to cold and explained these observed effects of phentolamine postulating that the resulting hypotension influences the baroreceptors which activate the appropriate centers in the central nervous system to increase sympathetic activity. It is this increased

sympathetic nerve activity (in the presence of receptor blockade) which liberates noradrenaline (and adrenaline) and thereby brings about a simultaneous increase in their synthesis. Such an increase in noradrenaline synthesis could very well have happened in the phentolamine treated rats in this set of experiments but the overall effect did not show an inhibitory influence, and instead, the insulin secretory response to glucose stimulation increased.

#### 5. Alpha-adrenergic regulation of insulin secretion

It is established that the process of cold-acclimation in rats results in a reduction of insulin secretion, both on the basal secretion and on the response to glucose-stimulation, and that this phenomenon is mediated through the effect of catecholamines (mainly noradrenaline). Many workers have demonstrated this inhibitory effect of the catecholamines upon insulin secretion, and have indicated that adrenaline is a more potent inhibitor of insulin secretion than noradrenaline. Furthermore, it is well established that the process of cold-acclimation increases endogenous catecholamine synthesis, both in the adrenal medulla (adrenaline and noradrenaline) and in the adrenergic nerve endings (noradrenaline).

So in order to verify the hypothesis that was put forward that this reduction of insulin secretion is brought into effect by the action of noradrenaline and that it is



mediated through the sympathetic nerve fibres, the effect on insulin secretion of bilateral adrenal demedullation, during the last week of cold-acclimation was studied. The results show that there are no significant differences in insulin secretion rates between this studied set of experiments and the cold-acclimated set ( $p \geq 0.50$ ). Basal insulin secretion rates in both sets were almost identical Fig. (12). Both experimental sets exhibited the biphasic insulin secretion pattern in response to glucose stimulation, peak values of the first phase of insulin release were identical, as well as both ranges of the second phase. These results clearly demonstrate that catecholamines originating from the adrenal medulla were not responsible for the inhibitory effect on insulin secretion and/or synthesis in the beta-cells of the pancreatic islets.

Leblanc and Nadeau (1961) demonstrated that after adrenalectomy the quantity of noradrenaline in the urine remained essentially unchanged in both the adrenalectomized and the normal rats. This indicates that noradrenaline secretion occurs outside the adrenals. Similarly, Hsieh, Carlson and Gray (1957) demonstrated that urinary noradrenaline is from extra-adrenal origin in adrenalectomized rats. In this context, it is also pertinent to recall that in demedullated animals, the urinary excretion of noradrenaline has been found to be elevated at rest and its increase following cold exposure was greater than in

controls (Johnson et al., 1966). Furthermore, Leduc (1961 a,b) reported that increase of adrenaline excretion induced by cold exposure was mainly due to an increased secretion from the adrenal medulla whilst the increased noradrenaline output resulted from an increased release from the adrenergic nerve endings.

Thus it might be concluded that noradrenaline originating from sympathetic postganglionic nerve endings is the effective catecholamine which inhibits insulin secretion during cold-acclimation. Phentolamine treatment during the last week of cold-acclimation which resulted in an increased insulin secretion in response to glucose stimulation, supports this conclusion. Phentolamine blocked the inhibitory effect of noradrenaline on insulin secretion. This blockade was very specific in action and it involved only the mechanism of insulin release in response to glucose stimulation and did not alter the basal insulin secretion rate. This basal insulin might be coming from a distinct pool with a specific release mechanism. It seems therefore that the regulatory influence of the sympathetic nervous system on the beta-cells is closely associated with glucose stimulation and involves a related insulin storage pool, although the hyperactivity of the alpha-adrenergic terminals associated with the beta-cells modulate the general synthetic and release mechanism of insulin during cold-acclimation. The total reduction in insulin secretion

rates observed during cold-acclimation is, thus, controlled directly by the sympathetic postganglionic fibers rather than by adrenal medullary secretions of catecholamines. Roy et al., (1977) suggested that the increased excretion of noradrenaline, adrenaline and metabolites is indicative of increased sympathetic activity and because of its extent, is highly suggestive of increased synthesis of catecholamines. Nevertheless, adrenaline could play as important a role as noradrenaline, but only after exhaustion or failure of the noradrenaline reserves. It was shown that after a drug-induced decrease of noradrenaline, adrenaline excretion increases, which indicates that the two hormones can replace each other in their thermogenic as well as other effects (Jansky, 1973). Besides all the above evidence, some specific laboratory studies on rats have shown that the catecholamines in the adrenal venous effluents after cold-acclimation are largely composed of noradrenaline and that the total output of catecholamines greatly exceeds control values (Smith, 1962). Such an increase in total catecholamines due to cold-acclimation could be of vital importance in activating the proper homeostatic mechanisms involved in the process of cold-acclimation. They might concern other target organs that have to do with various metabolic and thermogenic processes other than the beta-cells of the Islets of Langerhans of the pancreas, such as the liver, the muscles, the brown adipose tissue and the circulatory system.

Hart (1963) pointed out that in cold-acclimated rats, the control of cold thermogenesis shifts during cold-acclimation to the sympathetic autonomic system. The present results of the bilateral adrenal demedullation experiments exclude the effect of adrenal catecholamines on the beta-cells. These results indicate a direct effect of neural input upon insulin secretion. In order to demonstrate this direct neural response, an attempt was made to study the effect of sympathetic postganglionic stimulation on insulin release. However this proved to be unfruitful because of the difficulty in locating and tracing the fine postganglionic fibres to the rat pancreas. Porte et al. (1973) were able to demonstrate the direct sympathetic nervous effect on insulin release in the pancreas of the dog. Similarly, stimulation of the splanchnic nerve (in the calf) inhibits glucose induced insulin release (Bloom et al., 1973). Furthermore, pancreatic sympathectomy in rats, as reported by Sacca et al., (1977), resulted in a severe hypoglycemia due to increased insulin release. However, this was only a functional pancreatic sympathectomy which they defined as adrenal demedullation with intraperitoneal reserpine injection (2 mg/Kgm).

Fluorescence microscopy has been used to demonstrate adrenergic nerve fibres in islets of several mammalian species (Cegrell, 1963) and in the rat (Woods and Porte, 1974). Further evidence suggesting that the autonomic nervous system may be involved in the fine regulation of insulin secretion is

the demonstration of increased insulin secretion following vagal stimulation (Frohman et al., 1966, 1967; Kaneto et al., 1967).

In a brief summary of the mechanism associated with the adrenergic regulation of insulin secretion, it is pertinent to mention that the beta-cells of the pancreatic islets are equipped with an adenylyl cyclase-cyclic AMP-phosphodiesterase system. Turtle and Kipnis (1967 a) reported that alpha- and beta- adrenergic stimulation respectively decrease and increase the cyclic AMP content of the pancreatic beta-cells in vitro. Catecholamines are considered to affect the activity of this system (Porte and Robertson, 1973). In this connection it is argued that although beta-stimulation could increase insulin secretion via an accumulation of cyclic AMP within the beta-cell, alpha-stimulation inhibition of insulin secretion occurs via a mechanism independent of any action it may have to reduce the cyclic AMP concentration. It is proposed that alpha-adrenergic inhibition of insulin secretion may be mediated by a reduction of islet calcium ion uptake as demonstrated by Malaisse et al., (1970). Adrenaline (and noradrenaline) which inhibit glucose-induced insulin secretion (Milner and Hales, 1968, 1969), also inhibited glucose-induced ( $^{45}\text{Ca}^{++}$ ) uptake (Malaisse-Lagae & Malaisse, 1971), while insulinotropic agents were found to stimulate calcium uptake. Cyclic AMP

concentrations within the beta-cell are then seen as being maintained by a beta-adrenergic mechanism, whilst an alpha-adrenergic mechanism prevents the complete expression of this effect upon insulin secretion, possibly by inhibiting the calcium ion accumulation within the beta-cell. Although the potentiation of glucose-stimulated insulin release by cyclic AMP is specific regarding the adenosine moiety (Lernmark, 1974), the mechanism by which the adenylcyclase system affects insulin release is not fully understood, but it has been suggested that cyclic 3',5'-AMP could activate glycogen phosphorylase in beta-cells (Malaisse et al., 1967 c). This suggestion is based on the following observations: pancreatic tissue from normoglycemic rats, containing no detectable glycogen in the islet tissue, does not secrete insulin in the absence of glucose, and the stimulant effects of glucose and theophylline are reduced or abolished by mannoheptulose and 2-deoxyglucose. Furthermore, tissue obtained from rats made hyperglycemic with infusion of glucose, and containing glycogen within the islet tissue, responds to theophylline even in the absence of glucose. This stimulant effect is inhibited by 2-deoxyglucose but not by mannoheptulose, a result that suggests that the glucose normally used by the isolated pancreatic tissue is extracellular. In tissue from hyperglycemic rats, theophylline could stimulate glycogen phosphorylase and so provide an intracellular source

of glucose from stored glycogen. But since no such glycogen store is present in normal islets, this could not be the only operative mechanism.

The present results suggest that the alpha-adrenergic terminals of the sympathetic nervous fibres may be intimately involved in the mechanism, which control insulin secretion in the normal and the cold-acclimated rat pancreas. Stimulation of the sympathetic system and the release of catecholamines particularly noradrenaline, at adrenergic nerve terminals, are characteristics of cold stress. The high rate of loss of heat due to cold, necessitates a hyper active thermogenic process which utilizes larger quantities of glucose and free fatty acids than normal. This increased need for nutrients is supplied by the action of the catecholamines on the liver and the peripheral depots of fat, and thus thermogenic centres are able to use efficiently either glucose or fatty acids, without any change in plasma insulin concentration (which is, evidently, low during cold-acclimation). However, should the level of insulin increase for any reason, the release of these nutrients from the liver and fat cells would be impaired as insulin suppresses both the release of glucose from the liver (Franckson, Arnould, Malaisse and Conrad, 1964; Larner, Villar-Palasi and Richman, 1959; Norman, Pierguilio, Reid, Lester and Hechter, 1959), and of free fatty acids from fat depots (Halperin & Denton, 1969; Jungas and Ball, 1963, 1964; Mahler, Stafford, Tarrant and Ashmore, 1964; Toomey, Shaw, Reid and Young, 1970). This antilipolytic effect of insulin

on adipose tissue is, undoubtedly, one of the most important physiological actions of this hormone. That anti lipolysis is not simply due to reesterification of newly hydrolysed triglyceride fatty acids comes from the observation that the release of glycerol, as well as free fatty acid release, is decreased by the presence of insulin (Jungas and Ball, 1963, 1964). Since triglycerides are usually hydrolyzed to glycerol and free fatty acids within the adipocyte (Butcher, 1966), (and the fatty acids can be reesterified), glycerol release gives a more accurate reflection of the rates of lipolysis than does free fatty acid release (Chlouverakis, 1967). Insulin may inhibit the release of free fatty acids from adipose tissue by two mechanisms: a direct antilipolytic effect not dependent on glucose, and one that promotes intracellular reesterification of free fatty acids via the production of increased amounts of alpha-glycerol phosphate, secondary to augmented glucose metabolism (Blecher, 1968). Although not in complete agreement (Lisch et al., 1973; Mahler et al., 1964), most workers have found that insulin also inhibits basal lipolysis, i.e., the rate of glycerol release observed in the absence of added lipolytic hormones (Chlouverakis, 1967; Fain, 1967; Fain, Kovacev and Scow, 1966); The important role of insulin as an antilipolytic agent is further illustrated by the observation that lipolysis appears to be sensitive to very low levels of insulin (Fain et al., 1966). It is pertinent



to mention here that a large number of hormones are known to stimulate the release of free fatty acids from adipose tissue. These include adrenaline, noradrenaline, glucagon, ACTH, TSH, glucocorticoids, and growth hormone.

Thus, with all the preceding arguments and experimental results put together, it might be concluded that during cold-acclimation, by inhibiting insulin secretion, the catecholamines (especially noradrenaline released at the sympathetic nerve endings) are better able to sustain an altered metabolic steady state, and to maintain an adequate supply of nutrients for general body metabolism.

12)

REFERENCES

- 1 - Ahlborg, G., Felig, P., Hagenfeldt, L., Hendler, R. & Wahren, J. (1974) Substrate turnover during prolonged exercise in man, splanchnic and leg metabolism of glucose, FFA and amino acids. Journal of Clinical Investigation, 53, 1080-1090.
- 2 - Ahrens, R. A., Bishop, C. L. & Berdanier, C. D. (1972) Effects of age and dietary carbohydrate sources on the responses of rats to forced exercise. Journal of Nutrition, 102, 241-247.
- 3 - Allen, C. & Kendall, J. W. (1967) Maturation of the circadian rhythm of plasma corticosterone in the rat. Endocrinology, 80, 926-930.
- 4 - Anderson, E. & Long, J. A. (1947) The effect of hyperglycemia on insulin secretion as determined with the isolated rat pancreas in a perfusion apparatus. Endocrinology, 40, 92-97.
- 5 - Armin, J. & Grant, R. T. (1959) Further observations on vasoconstrictor substances in blood of rabbit and man. Journal of Physiology, 138(3), 401-416.
- 6 - Ashcroft, S. J. H. & Randle, P. J. (1968 a) Glucose metabolism and insulin secretion by pancreatic islets. The Lancet, 1, 278-280.
- 7 - ----- (1968 b) Glucose-6-phosphate activity of mouse pancreatic islets. Nature (London), 219, 857-858.

- 8 - Baker, D. G. & Sellers, E. A. (1953) Carbohydrate metabolism in the rat exposed to low environmental temperature. American Journal of Physiology, 174(3), 459-461.
- 9 - Baker, D. G. & Ashworth, M. A. (1958) Effect of exposure to cold on the islets of Langerhans in the rat. American Journal of Physiology, 192, 597-598.
- 10 - Balasse, E., Couturier, E. & Franckson, J. R. M. (1967) Influence of sodium beta-hydroxybutyrate on glucose and free fatty acid metabolism in normal dogs. Diabetologia, 3, 488-493.
- 11 - Basake, J. C., Lopez, N. L., Viktora, J. K. & Wolff, F. W. (1971) Insulin secretion studied in the perfused rat pancreas. Diabetes, 20, 449-456.
- 12 - Beck, L. V., Zaharko, D.S., Roberts, N., McNeil, T., King, C. & Blankenbaker, R. (1964) Insulin assay by combined use of I<sup>131</sup>-labelled insulin, anti-insulin serum and insulinase. Life Sciences, 3, 545-550.
- 13 - Beck, L. V., Zaharko, D. S. & Kalser, S. C. (1967) Variation in serum insulin and glucose of rats with chronic cold exposure. Life Sciences, 6, 1501-1506.
- 14 - Belzer, F. O., Ashby, B. S. & Huang, J. S. (1968) Etiology of rising perfusion pressure in isolated organ perfusion. Annals of Surgery, 168, 382-391.
- 15 - Benedict, C. R., Fillenz, M. & Stanford, S. C. (1977 a) Plasma noradrenaline levels during exposure to cold. Journal of Physiology (London), 269(1), 47p-48p.
- 16 - Benedict, C. R., Fillenz, M., Stanford, C. & Valero, I. (1977 b) Plasma noradrenaline levels as a measure of noradrenaline release. British Journal of Pharmacology, 60, 287p.

- 17 - Bennett, L. L., Curry, D. & Curry, K. (1973) Differences in insulin release in response to glucose and to butamide stimulation. Proceedings of the Society for Experimental Biology and Medicine, 144(2), 436-439.
- 18 - Berdanier, C. & Moser, P. B. (1972) Metabolic responses of adrenalectomized rats to exercise. Proceedings of the Society for Experimental Biology and Medicine, 141, 490-493.
- 19 - Bergman, R. N. & Miller, R. E. (1973) Direct enhancement of insulin secretion by vagal stimulation of the isolated pancreas. American Journal of Physiology, 225(2), 481-485.
- 20 - Blecher, M. (1968) Action of insulin on a glucose transport mechanism in the plasma membrane of the isolated adipose cell participation of membrane phospholipids and cyclic adenosine monophosphate in the transport processes. Endocrinology, 5, 145-.
- 21 - Bloom, S. R., Edwards, A. V. & Vaughan, J. A. (1973) The role of the sympathetic innervation in the control of plasma glucagon concentration in the calf. Journal of Physiology (London), 233, 457-466.
- 22 - Boshart, C. R., Will, L., Pirre, A. & Ringler, I. (1965) The effects of reserpine, guanethidine and other autonomic drugs on free fatty acids mobilization induced by phentolamine. Journal of Pharmacology and Experimental Therapeutics, 149, 57-64.
- 23 - Bressler, R., Cordon, M. V. & Bredel, K. (1969) Studies on the role of adenyl cyclase in insulin secretion. Archives of Internal Medicine, 123, 248-251.
- 24 - Buse, M. G., Allan, D., Kuperminc, D. & Buse, J. (1970) Effect of alpha-adrenergic blockade on insulin secretion in man. Metabolism, 19, 219-225.

- 25 - Butcher, R. W. (1966) Cyclic 3', 5'-AMP and the lipolytic effects of hormones on adipose tissue. Pharmacological Reviews, 18, 237-241.
- 26 - Campbell, J. & Rastogi, K. S. (1966) Effects glucose and epinephrine on serum insulin and insulin secretion in dogs. Endocrinology, 79, 830-835.
- 27 - Case, R. M. & Clausen, T. (1973) The relationship between calcium exchange and enzyme secretion in the isolated rat pancreas. Journal of Physiology (London), 235(1), 75-102.
- 28 - Cegrell, L. (1963) Adrenergic nerves and monoamine-containing cells in the mammalian endocrine pancreas. Acta Physiologica Scandinavica Suppl., 314, 17-23.
- 29 - Cerasi, E. & Luft, R. (1967) The plasma insulin response to glucose infusion in healthy subjects and in diabetes mellitus. Acta Endocrinologica, 55, 278-345.
- 30 - Cerasi, E. & Luft, R. E. (1969) The effect of an adenosine-3'-5'-monophosphate diesterase inhibitor (aminophylline) on the insulin response to glucose infusion in prediabetic and diabetic subjects. Hormone & Metabolic Research, 1, 162.
- 31 - Cerasi, E., Effendic, S. & Luft, R. (1969) Role of adrenergic receptors in glucose-induced insulin secretion in man. The Lancet, 2, 301-302.
- 32 - Chin, A. K. & Evonuk, E. (1971) Changes in plasma catecholamine and corticosterone levels after muscular exercise. Journal of Applied Physiology, 30, 205-207.
- 33 - Chiu, D. T. J. & Cheng, K. K. (1976) Circulatory changes in cold-acclimation and cold stress. Clinical and Experimental Pharmacology and Physiology, 3, 449-452.

- 34 - Chlouverakis, C. (1967) Factors affecting the inhibitory action of insulin on lipolysis in a glucose-free medium. Endocrinology, 81, 521-526.
- 35 - Chowers, I., Lavy, S. & Harpen, L. (1966) Effect of insulin administered intracisternally on the glucose level of the blood and the cerebrospinal fluid in vagotomized dogs. Experimental Neurology, 14, 383-389.
- 36 - Chowers, I., Siegel, R. A., Conforti, N. & Baranes, L. (1977) The effects of acclimation to alternating environmental temperature on metabolic and endocrine responses in guinea pigs, during acute heat and cold exposure. International Journal of Biometeorology (Netherl.), 21(1), 64-74.
- 37 - Clark, L. C. & Gollan, F. (1966) Survival of mammals breathing organic liquids equilibrated with oxygen at atmospheric pressure. Science, 152, 1755-1756.
- 38 - Clark, J. L. & Steiner, D. F. (1969) Insulin biosynthesis in the rat: demonstration of two proinsulins. Proceedings of the National Academy of Sciences (US), 62, 278-285.
- 39 - Clayton, G. W., Librik, L., Gardener, R. L. & Guillmen, R. (1963) Studies on the circadian rhythm of pituitary adrenocorticotrophic release. Journal of Clinical Endocrinology, 23, 975-980.
- 40 - Coore, H. G. & Randle, P. J. (1964 a) Inhibition of glucose phosphorelation by mannoheptulose. Biochemical Journal, 91, 56-59.
- 41 - ----- (1964 b) Regulation of insulin secretion studied with pieces of rabbit pancreas incubated in vitro. Biochemical Journal, 93, 66-78.
- 42 - Curry, D. L., Bennett, L. L. & Grodsky, G. M. (1968 a) Dynamics of insulin secretion by the perfused rat pancreas. Endocrinology, 83, 572-584.

- 43 - ----- (1968 b) Multiphasic insulin secretion by the isolated perfused rat pancreas. Federation Proceedings, 27, 496.
- 44 - Curry, D. L. (1971) Insulin secretory dynamics in response to slow rise and square-wave stimuli. American Journal of Physiology, 221(1), 324-328.
- 45 - Dale, H. H. & Schuster, E. H. J. (1928) The Dale-Schuster perfusion pump. Journal of Physiology, 64(4), 356.
- 46 - Daniel, P. M. & Henderson, J. R. (1967) Effect of vagal stimulation on plasma insulin and glucose levels in blood. Journal of Physiology, 192, 317-327.
- 47 - Davis, S. R. & Mephram, T. B. (1971) Perfusion of the isolated guinea-pig mammary gland. Journal of Physiology, 222, 13p-14p.
- 48 - ----- (1974) Amino acid and glucose uptake by the isolated perfused guinea-pig mammary gland. Quarterly Journal of Experimental Physiology, 59, 113-130.
- 49 - Dawkins, M. J. R. & Hull, D. (1964) Brown adipose tissue and the response of new-born rabbit to cold. Journal of Physiology, 172, 216-238.
- 50 - Dawson, R. M. C., Elliott, D. C., Elliott, W. H. & Jones, K. M. (1969) In Data for Biochemical Research, ed. Dawson, R. M. C., 2nd ed., pp. 507. Clarendon Press: Oxford.
- 51 - Day, J. L. (1975) The metabolic consequences of adrenergic blockade. Metabolism: Clinical & Experimental, 24, 987-996.
- 52 - DeBodo, R. C. & Altszuler, N. (1958) Insulin hypersensitivity and physiological insulin antagonists. Physiological Reviews, 38, 389-444.

- 53 - Deckert, T. (1968) Stimulation of insulin secretion by glucagon and secretin. Acta Endocrinologica, 57, 578-584.
- 54 - Depocas, F. (1959 a) Turnover of plasma glucose in anaesthetized warm- and cold-acclimated rats exposed to cold. Canadian Journal of Biochemistry and Physiology, 37, 175-181.
- 55 - ----- (1959 b) The pool size, turnover rate, and oxidation rate of body glucose in anaesthetized warm- and cold-acclimated rats exposed to a warm environment. Canadian Journal of Biochemistry and Physiology, 37, 285-295.
- 56 - ----- (1960 a) Calorigenesis from various organ systems in the whole animal. Federation Proceedings, 19(5), 19-24.
- 57 - ----- (1960 b) Glucose metabolism in warm- and cold-acclimated rats. Federation Proceedings, 19(5), 106-109.
- 58 - ----- (1961) Hypothermia and effects of cold. British Medical Bulletin, 17, 1-73.
- 59 - ----- (1962) Body glucose as fuel in white rats exposed to cold: results with fasted rats. American Journal of Physiology, 202(5), 1015-1018.
- 60 - Depocas, F. & Masironi, R. (1960) Body glucose as fuel for thermogenesis in the white rat exposed to cold. American Journal of Physiology, 199, 1051-1055.
- 61 - Depocas, F. & Secours, V. (1960) The calorogenic response of cold-acclimated white rats to infused noradrenaline. Canadian Journal of Biochemistry and Physiology, 38(2), 107-114.
- 62 - Des Marais, A. & Dugal, L. P. (1951) Circulation peripherique et teneur des surrenales en adrenaline et en arterenol (noradrenaline) chez le rat blanc expose au froid. Canadian Journal of Medical Sciences, 29, 90-99.



- 130
- 63 - Devrin, S. & Recant, O. L. (1966) Effect of glucagon on insulin release in vitro. The Lancet, 2, 1227-1228.
- 64 - Dupré, J., Curtis, J. D., Waddell, R. W., Unger, R. H. & Beck, J. C. (1969) Effects of secretin, pancreozymin or gastrin on the response of the endocrine pancreas to administration of glucose or arginine in man. Journal of Clinical Investigation, 48, 745-757.
- 65 - Efendic, S., Cerasi, E. & Luft, R. (1973) Effect of blockade of the alpha-adrenergic receptors on insulin response to glucose infusion in prediabetic subjects. Acta Endocrinologica, 74, 542-547.
- 66 - Euler, U. S. V. (1971) Adrenergic neurotransmitter functions. Science, 173, 202-206.
- 67 - Fain, J. N., Kovacev, V. P. & Scow, R. O. (1966) Antilipolytic effect of insulin in isolated fat cells of the rat. Endocrinology, 78, 773-778.
- 68 - Fain, J. N. (1967) Adrenergic blockade of hormone induced lipolysis in isolated fat cells. Annals of (NY) Academy of Sciences, 139, 870-890.
- 69 - Floyd, J. C. jr., Fajans, S. S., Conn, J. W., Knopf, R. F. & Rull, J. (1966) Stimulation of insulin secretion by amino acids. Journal of Clinical Investigation, 45, 1487-1502.
- 70 - Floyd, J. C. jr., Fajans, S. S., Pek, S., Thiffault, C., Knopf, R. F. & Conn, J. W. (1970) Synergistic effect of essential amino acids and glucose upon insulin secretion in man. Diabetes, 19, 109-115.
- 71 - Foster, D. O., Lorraine Frydman, M. & Usher, J. R. (1977) Nonshivering thermogenesis in the rat. I: The relation between drug-induced changes in thermogenesis and changes in the concentration of plasma cyclic AMP. Canadian Journal of Physiology and Pharmacology, 55(1), 52-64.

- 72 - Franckson, J. R., Arnould, Y., Malaisse, W. & Conrad, V. (1964) Glucose metabolism in the normal anaesthetized dog injected successively with anti-insulin serum and insulin. Diabetes, 13, 532-541.
- 73 - Frohman, L. A., Ezdinli, E. Z. & Javid, R. (1966) Effect of vagal stimulation on insulin secretion. Diabetes, 15(7), 522.
- 74 - ----- (1967) Effect of vagotomy and vagal stimulation on insulin secretion. Diabetes, 16, 443-448.
- 75 - Fussganger, R. D., Hinz, M., Goberna, R., Jaros, P., Karsten, C., Pfeiffer, E. F. & Raptis, S. (1969) Comparative studies on the dynamics of insulin secretion following HB419 and tolbutamide on the perfused isolated rat pancreas and the perfused isolated islets of Langerhans. Hormone and Metabolic Research Suppl., 1, 34-40.
- 76 - Gagliardino, J. J. & Martin, J. M. (1966) Studies on the mechanism of insulin release. Metabolism, 15(12), 1068-1075.
- 77 - Galbo, H., Holst, J. J. & Christensen, N. J. (1975) Glucagon and plasma catecholamine responses to graded and prolonged exercise in man. Journal of Applied Physiology, 38, 70-76.
- 78 - Gerhards, E. & Ruel, M. (1974) Insulin secretion of the isolated perfused pancreas of the chinese hamster. Acta Endocrinologica, 76(2), 302-318.
- 79 - Gerish, J. E., Karam, J. H. & Forsham, P. H. (1973) Stimulation of glucagon secretion by epinephrine in man. Journal of Clinical Endocrinology and Metabolism, 37, 479-481.
- 80 - Gerish, J. E., Langlois, M., Noacco, C., Schneider, V. & Forsham, P. H. (1974) Adrenergic modulation of pancreatic glucagon secretion in man. Journal of Clinical Investigation, 53, 1441-1446.

- 81 - Geyer, R. P., Monroe, R. G. & Taylor, K. (1968) Survival of rats totally perfused with fluorocarbon-detergent preparation. In Organ Perfusion and Preservation, ed. Norman, J. C. Ch. 9, pp.85-96. New York:Appleton-Century-Crofts.
- 82 - Goberna, R., Tamarit, J.jr., Osorio, J., Fussganger, R., Tamarit, J. & Pfeiffer, E. (1974) Action of beta-hydroxy butyrate, acetoacetate and palmitate on the insulin release in the perfused isolated rat pancreas. Hormone and Metabolic Research, 6(4), 256-260.
- 83 - Gollan, F. & Clark, L. C.jr. (1966) Organ perfusion with fluorocarbon fluid. Physiologist, 9, 191-192.
- 84 - Gollan, F., McDemott, J., Dugger, A. & Musil, G. (1972) Experimental study of perfusion of rabbits with fluorocarbon fluid in the acute asanguineous state. Resuscitation, 1, 235-246.
- 85 - Gotfredsen, C. F. (1976) Dynamics of sulfonyleurea-induced insulin release from isolated perfused rat pancreas. Diabetologia, 12, 339-342.
- 86 - Govier, W. C., Lovenberg, W. & Sjoerdsma, A. (1969) Studies on the role of catecholamines as regulators of tyrosine aminotransferase. Biochemical Pharmacology, 18, 2661-2666.
- 87 - Grobecker, H., Saavedra, J. M., McCarty, R., Chiueh, C. C. & Kopin, I. J. (1977) Dopamine-beta-hydroxylase activity and catecholamine concentrations in plasma: experimental and essential hypertension. Postgraduate Medical Journal, 53(3), 43-48.
- 88 - Grodsky, G. M. & Forsham, P. H. (1960) Immunochemical assay of total extractable insulin in man. Journal of Clinical Investigation, 39, 1070-1079.
- 89 - Grodsky, G. M., Batts, A., Bennett, L., Vcella, C., McWilliams, N. & Smith, D. (1963) Effects of carbohydrates on secretion of insulin from isolated rat pancreas. American Journal of Physiology, 205, 638-644.

- 90 - Grodsky, G. M. & Bennett, L. L. (1963) Insulin secretion from the isolated pancreas in the absence of insulinogenesis. Proceedings of the Society for Experimental Biology and Medicine, 114, 769-771.
- 91 - ----- (1966) Cation requirements for insulin secretion in the isolated perfused pancreas. Diabetes, 15, 910-913.
- 92 - Grodsky, G. M., Bennett, L. L., Smith, D. F. & Schmid, G. G. (1967) Effect of pulse administration of glucose or glucagon on insulin secretion in vitro. Metabolism, 16, 222-233.
- 93 - Grodsky, G. M., Curry, D. L., Bennett, L. L. & Rodrigo, J. J. (1968) Factors influencing different rates of insulin release in vitro. Acta Diabetologica Latina, 5(1), 140-161.
- 94 - Grodsky, G. M., Landahl, H., Curry, D. & Bennett, L. (1970) In vitro studies suggesting a two-compartmental model for insulin secretion. In Structure and Metabolism of the Pancreatic Islets, ed. Falkmer, S., Hellman, B. & Taljedal, I.-B. pp.409-420. Oxford:Pergamon Press.
- 95 - Grodsky, G. M. (1972 a) A threshold distribution hypothesis for packet storage of insulin. II: Effect of calcium. Diabetes, 21(2), 584-593.
- 96 - ----- (1972 b) A threshold distribution hypothesis for packet storage of insulin and its mathematical modeling. Journal of Clinical Investigation, 51, 2047-2059.
- 97 - Guernsey, D. L. & Stevens, E.D. (1977) The cell membrane sodium pump as a mechanism for increasing thermogenesis during cold-acclimation in rats. Science (U.S.A.), 196, 908-910.

- 98 - Haggendal, J., Hartley, L. H. & Saltin, B. (1970) Arterial noradrenaline concentration during exercise in relation to the relative work levels. Scandinavian Journal of Clinical and Laboratory Investigation, 26, 337-342.
- 99 - Hales, C. N. & Randle, P. J. (1963) Immunoassay of insulin with insulin antibody precipitate. Biochemical Journal, 88, 137-146.
- 100 - Hales, C. N. & Milner, R. D. G. (1968) Cations and the secretion of insulin from rabbit pancreas in vitro. Journal of Physiology (London), 199, 177-187.
- 101 - Hales, C. N. (1970) Ion fluxes and membrane function in beta-cells and adipocytes. Acta Diabetologica Latina, 7(1), 64-75.
- 102 - Halperin, M. L. & Denton, R. M. (1969) Regulation of glycolysis and L-glycerol 3-phosphate concentration in rat epididymal adipose tissue in vitro. Biochemical Journal, 113, 207-214.
- 103 - Hammond, R. P. & Hamolsky, M. W. (1970) Thyroid-catecholamine interactions: studies on brown adipose tissue. Federation Proceedings, 29, 2326.
- 104 - Hannon, J. P. (1963) Cellular mechanisms in the metabolic acclimatization to cold. In Temperature- Its Measurement and Control in Science and Industry, ed. Hardy, J. D. volume 3, Ch. 41, pp.469-484. New York: Reinhold.
- 105 - Hardman, M. J. & Hull, D. (1970) Fat metabolism in brown adipose tissue in vivo. Journal of Physiology, 206, 263-273.
- 106 - Hart, J. S. (1960) Energy metabolism during exposure to cold. Federation Proceedings, 19(5), 15-19.

- 107 - ----- (1962) Physiological responses to cold in nonhibernating homeotherms. In Temperature- Its Measurement and Control in Science and Industry, ed. Hardy, J. D. volume 3, Ch. 35, pp. 373-406. New York: Reinhold.
- 108 - Harvey, W. D., Faloon, C. R. & Unger, R. H. (1974) The effect of adrenergic blockade on exercise-induced hyperglucagonemia. Endocrinology, 94, 1254-1258.
- 109 - Hellerström, C. (1964) A method for the microdissection of intact pancreatic islets of mammals. Acta Endocrinologica, 45, 122-132.
- 110 - Hellerström, A., Andersson, R., Gunnarsson, C. & Berne, K. A. (1974) Cytophysiology and metabolism of pancreatic beta-cell. Endocrinologia Experimentalis, 8, 115-126.
- 111 - Herbert, V., Lau, K. S., Gottlieb, C. W. & Bleicher, S. J. (1965) Coated charcoal immunoassay of insulin. Journal of Clinical Endocrinology, 25, 1375-1384.
- 112 - Hertelendy, F., Machlin, L. J., Gordon, R., Horino, M. & Kipnis, D. (1966) Lipolytic activity and inhibition of insulin release by epinephrine in the pig. Proceedings of the Society of Experimental Biology (N.Y.), 121, 675-677.
- 113 - Himms-Hagen, J. (1972) Lipid metabolism during cold exposure and during cold-acclimation. Lipids, 7, 310-323.
- 114 - Holak, H., Baldys, A., Jarzab, B., Wystrychowski, A. & Skrzypek, J. (1978) Changes in serum (TSH) level after intraventricular injection of various neuromediators in rats. Acta Endocrinologica, 87, 279-282.
- 115 - Horino, M., Machlin, L. J., Hertelendy, F. & Kipnis, D. M. (1968) Effect of short-chain fatty acids on plasma insulin in ruminants and non-ruminant species. Endocrinology, 82, 118-128.

- 116 - Horwitz, B. A. (1971) In Nonshivering Thermogenesis,  
Proceedings of the Symposium, pp.221. Amsterdam:  
Swets & Zeitlunger.
- 117 - Howell, S. L. & Taylor, K. W. (1966) Effects of glucose  
concentration on incorporation of ( $^3\text{H}$ ) Leucine into  
insulin using isolated mammalian islets of Langerhans.  
Biochimica et Biophysica Acta, 130, 519-521.
- 118 - Howland, R. J. (1967) Seasonal variations in the activity of  
the islets of Langerhans of heterothermic and homeothermic  
mammals. Thesis: University of Hull.
- 119 - Howland, R. J. & Nowell, N. W. (1968) Seasonal changes of  
plasma insulin concentration in the rat. Journal of  
Endocrinology, 40, vi-vii.
- 120 - Hsieh, A. C. & Carlson, L. D. (1957) Role of adrenaline and  
noradrenaline in chemical regulation of heat production.  
American Journal of Physiology, 190, 243-246.
- 121 - Hsieh, A. C., Carlson, L. D. & Gray, J. (1957) Role of the  
sympathetic nervous system in the control of chemical  
regulation of heat production. American Journal of  
Physiology, 190(2), 247-251.
- 122 - Hull, D. & Segall, M. M. (1965) The contribution of brown  
adipose tissue to heat production in the new-born rabbit.,  
Journal of Physiology, 181, 449-457.
- 123 - Imura, H., Kato, Y., Ikeda, M., Morimoto, M. & Yawata, M. (1971)  
Effects of adrenergic blocking or stimulating agents on  
plasma G.H., immunoreactive insulin and blood FFA levels in  
man. Journal of Clinical Investigation, 50, 1069-1079.

- 124 - Jansky, L. (1973) Non-shivering thermogenesis and its thermoregulatory significance. Biological Reviews, 48, 85-132.
- 125 - Johnson, G. E. Schonbaum, E. & Sellers, E.A. (1966) Cold exposure: pharmacologic investigation of the compensatory mechanisms in the maintenance of normothermia. Federation Proceedings, 25, 1216-1219.
- 126 - Jolin, T. & Montes, A. (1973) Daily rhythm of plasma glucose and insulin levels in rats. Hormone Research, 4, 153-156.
- 127 - Joost, H. G., Beckmann, J., Holze, S., Lenzen, S., Poser, W. & Hasselblatt, A. (1976) Inhibition of insulin and glucagon release from the perfused rat pancreas by cyproheptadine (Periactinol, Nuran). Diabetologia, 12, 201-206.
- 128 - Jungas, R. L. & Ball, E. G. (1963) Studies on the metabolism of adipose tissue, XII: The effects of insulin and epinephrine on FFA and glycerol production in the presence and absence of glucose. Biochemistry, 2, 383-388.
- 129 - ----- (1964) Studies on the metabolism of adipose tissue. XVII: In vitro effects of insulin upon the metabolism of the carbohydrate and triglyceride stores of adipose tissue from fasted-refed rats. Biochemistry, 3, 1696-1702.
- 130 - Kajinuma, H., Kaneto, A., Kuzuya, T. & Nakao, N. (1968) Effects of metacholine on insulin secretion in man. Journal of Clinical Endocrinology and Metabolism, 28, 1384-1388.
- 131 - Kaneto, A., Kosaka, K. & Nakao, K. (1967) Effects of stimulation of the vagus nerve on insulin secretion. Endocrinology, 80, 530-536.
- 132 - Kaneto, A., Kajinuma, H., Kosaka, K. & Nakao, K. (1968) Stimulation of insulin secretion by parasympathomimetic agents. Endocrinology, 83, 651-658.



- 133 - Kaneto, A., Kajinuma, H., Hayashi, M. & Kosaka, K. (1974)  
Effect of splanchnic nerve stimulation on glucagon and  
insulin secretion. Endocrinologia Japonica, 20(6),  
609-617.
- 134 - Kansal, P. C. & Buse, M. G. (1967) The effect of adrenergic  
blocking agents on plasma insulin and blood glucose during  
urethane or epinephrine induced hypoglycemia. Metabolism,  
16, 548-556.
- 135 - Karam, J. H., Grodsky, G. M. & Forsham, P. (1963) Excessive  
insulin response to glucose in obese subjects as measured  
by immunochemical assay. Diabetes, 12, 197-204.
- 136 - Karam, J. H., Grasso, H. G., Wegienka, L. O., Grodsky, G. M. &  
Forsham, P. (1966) Effects of selected hexoses, of  
epinephrine and of glucagon on insulin secretion in man.  
Diabetes, 15, 571-578.
- 137 - Katada, J. & Ui, M. (1977) Perfusion of the pancreas isolated  
from pertussis-sensitized rats: potentiation of insulin  
secretory response due to beta-adrenergic stimulation.  
Endocrinology, 101, 1247-1255.
- 138 - Kayser, C. (1937) Compt. Rend. Soc. Biol., 126, 701 & 1219,  
(cited by Depocas, 1960 b).
- 139 - Kennedy, D. R., Hammond, R. P. & Hamolsky, M. W. (1977)  
Thyroid cold-acclimated influences on norepinephrine  
metabolism in brown fat. American Journal of Physiology,  
232(6), E565-E569.
- 140 - Ketterer, H., Eisentraut, A. M. & Unger, R. H. (1967) Effect  
upon insulin secretion of physiologic doses of glucagon  
administered via the portal vein. Diabetes, 16, 283-288.
- 141 - Kidson, W. & Lazarus, L. (1973) The glycaemic stimulus to  
early phase insulin release: quantitation of beta-cell  
function. Hormone and Metabolic Research, 5(6), 387-391.

- 142 - Kilo, C., Long, C. L., Bailey, R.M., Kock, M. B. & Recant, L., (1962) Studies to determine whether glucose must be metabolised to induce insulin release. Journal of Clinical Investigation, 41, 1372-1373.
- 143 - Kilo, C., Devrim, S., Bailey, R. & Recant, L. (1967) Studies in vivo and in vitro of glucose-stimulated insulin release. The effects of metabolizable sugars, tolbutamide and 2-deoxyglucose. Diabetes, 16, 377-385.
- 144 - Kris, A. O., Miller, R. E., Wherry, F. E. & Mason, J. W. (1966) Inhibition of insulin secretion by infused epinephrine in rhesus monkey. Endocrinology, 78, 87-97.
- 145 - Kuroshima, A., Doi, K., Yahata, T. & Ohno, T. (1977) Improved cold tolerance and its mechanism in cold-acclimated rats by high fat diet feeding. Canadian Journal of Physiology and Pharmacology, 55, 943-950.
- 146 - Lacy, P.E. (1957) Electron microscopy of the normal islets of Langerhans: Studies in the dog, rabbit, guinea pig and rat. Diabetes, 6, 498-507.
- 147 - ----- (1967) The pancreatic beta-cell. New England Journal of Medicine, 276, 187-192.
- 148 - Larner, J., Villar-Palasi, C. & Richman, D. J. (1959) Insulin stimulated glycogen formation in rat diaphragm. Annals of (N.Y.) Academy of Sciences, 82, 345-353.
- 149 - LeBlanc, J. A. & Nadeau, G. (1961) Urinary excretion of adrenaline and noradrenaline in normal and cold-adapted animals. Canadian Journal of Biochemistry and Physiology, 39, 215-217.
- 150 - Leduc, J. (1961 a) Excretion of catecholamines in rats exposed to cold. Acta Physiologica Scandinavica, 51, 94-95.

- 151 - ----- (1961 b) Catecholamine production and release in exposure and acclimation to cold. Acta Physiologica Scandinavica, 53 (183), 1-101.
- 152 - Lenzen, S. & Hasselblatt, A. (1974) The effect of thyroxine treatment on the dynamics of insulin release from the isolated perfused rat pancreas. Naunyn-Schmiedeberg's Archives of Pharmacology, 282(3), 317-321.
- 153 - Lerner, R. L. (1977) The augmentation effect of secretion on the insulin responses to known stimuli: specificity for glucose. Journal of Clinical Endocrinology and Metabolism, 45, 1-9.
- 154 - Lernmark, A. (1974) Specificity of cyclic-AMP potentiation of glucose-stimulated insulin release. Hormone Research (Basel). 5(4), 227-233.
- 155 - Lin, B. J. & Haist, R. E. (1969) Insulin biosynthesis: effects of carbohydrates and related compounds. Canadian Journal of Physiology and Pharmacology, 47, 791-801.
- 156 - Lisch, H.-J., Sailer, S., Sandhofer, F., Schennech, W. & Braunsteiner, H. (1973) Action of insulin and glucose on the re-esterification rate of free fatty acids in isolated human fat cells. Diabetologia, 9(6), 499-504.
- 157 - Loubatières, A., Mariani, M. M., Chapal, J. & Portal, A. (1967) Action frenatrice de faibles doses d'adrénaline et de noradrénaline sur l'insulino-sécrétion étudiée sur le pancréas isolé et perfusé du rat. Comptes Rendus des Séances-Société de Biologie, 161, 2578.
- 158 - Loubatières, A., Mariani, M. M. & Chapal, J. (1970 a) Insulino-sécrétion étudiée sur le pancréas isolé et perfusé du rat. II: action des catécholamines et des substances bloquant les récepteurs adrénergiques. Diabetologia, 6, 457-466 & 533.

- 159 - ----- (1970 b) Etude physiologique et pharmacologique de l'insulinosécrétion sur le pancréas isolé et perfusé du rat. I: Effects du glucose et des sulfamides hypoglycémisants. Journal of Pharmacology, 1, 7-24.
- 160 - Loubatières, A., Alric, R., Mariani, M. M. & Chapel, J. (1972) Pancréas isolé et perfusé du rat. Fiche Technique Journal de Pharmacologie, 3, 103-108.
- 161 - Loubatières, A. & Loubatières-Mariani, M. M. (1974) In vitro secretion of insulin after glucose sulfonylureas, adrenergic and cholenergic substances studied by isolated perfused rat pancreas. Endocrinologia Experimentalis, 8(2), 75-87.
- 162 - Loubatières-Mariani, M. M., Chapal, J., Alric, R. & Loubatières, A. (1973) Studies of the cholinergic receptors involved in the secretion of insulin using isolated perfused rat pancreas. Diabetologia, 9(6), 439-446.
- 163 - Loubatières-Mariani, M. M., Chapal, J., Ribes, G. & Loubatières, A. (1977) Discrepancies in the response of the insulin secreting cells of the dog and rat to different adrenergic stimulating agents. Acta Diabetologica Latina, 14(3-4), 144-155.
- 164 - Madison, L. L., Mebane, D., Unger, R. H. & Lockner, A. (1964) The hypoglycemic action of ketones. II: Evidence for a stimulatory feedback of ketones on the pancreatic beta-cells. Journal of Clinical Investigation, 43, 408-415.
- 165 - Maekubo, H., Moriya, K. & Hiroshige, T. (1977) Role of ketone bodies in nonshivering thermogenesis in cold-acclimated rats. Journal of Applied Physiology, 42(2), 159-165.
- 166 - Mahler, R., Stafford, W. S., Tarrant, M. E. & Ashmore, J. (1964) The effect of insulin on lipolysis. Diabetes, 13, 297-302.
- 167 - Mahler, R. J. & Weisberg, H. (1968) Pancreozymin and serum-insulin levels. The Lancet, 1, 860-861.

- 168 - Malaisse, W., Malaisse-Lagae, F. & Wright, P. H. (1967 a)  
A new method for the measurement in vitro of pancreatic  
insulin secretion. Endocrinology, 80, 99-107.
- 169 - Malaisse, W., Malaisse-Lagae, F., Wright, P. H. & Ashmore, J. A.  
(1967 b) Effects of adrenergic and cholinergic agents  
upon insulin secretion in vitro. Endocrinology, 80, 975-978.
- 170 - Malaisse, W., Malaisse-Lagae, F. & Mayhew, D. (1967 C) A  
possible role for the adenylcyclase system in insulin  
secretion. Journal of Clinical Investigation, 46, 1724-1734.
- 171 - Malaisse, W., Malaisse-Lagae, F., Lacy, P. E., & Wright, P. H.  
(1967 d) Insulin secretion by isolated islets in presence  
of glucose, insulin and anti-insulin serum. Proceedings of  
the Society for Experimental Biology and Medicine, 124,  
497-500.
- 172 - Malaisse, W. & Malaisse-Lagae, F. (1968) Stimulation of insulin  
secretion by noncarbohydrate metabolites. Journal of  
Laboratory and Clinical Medicine, 72, 438-448.
- 173 - Malaisse, W., Brisson, G. & Malaisse-Lagae, F. (1970) The  
stimulus secretion coupling of glucose-induced insulin  
release. I: Interaction of epinephrine and alkaline  
earth cations. Journal of Laboratory and Clinical Medicine,  
76, 895-902.
- 174 - Malaisse, W. & Malaisse-Lagae, F. (1970) Uptake of Calcium (45)  
by isolated islets of Langerhans. Diabetes, 19, 365.
- 175 - ----- (1970 a) Biochemical, pharmacological, and  
physiological aspects of the adenyl cyclase-phosphodiesterase  
system in the pancreatic beta-cells. In The Structure and  
Metabolism of the Pancreatic Islets, ed. Falkmer, S.,  
Hellman, B. and Taljedahl, I.-B., pp.435-443. Oxford:  
Pergamon Press.

- 176 - Malaisse-Lagae, F. & Malaisse, W. (1971) The stimulus secretion coupling of glucose-induced insulin release. III: Uptake of  $^{45}\text{Ca}$  by isolated islets of Langerhans. Endocrinology, 88, 72-80.
- 177 - Mangay, D., De Ruyter, H. A., Tonber, J. L., Crougns, R. J. M., Schopman, W. & Lequin, R. M. (1967) Rapid rise of insulin concentration in plasma after intravenous administration of sodium tolbutamide. The Lancet, 1, 361-362.
- 178 - Mansour, T. E. & Hewitt, W. F. jr. (1954) Sensitivity to insulin during adrenocortical response to cold stress in rats. Endocrinology, 54(1), 20-25.
- 179 - Masironi, R. & Depocas, F. (1961) Effect of cold exposure on respiratory  $^{14}\text{CO}_2$  production during infusion of albumin-bound palmitate  $1\text{-}^{14}\text{C}$  in white rat. Canadian Journal of Biochemistry and Physiology, 39(2), 219-224.
- 180 - Mayhew, D. A., Wright, P. H. & Ashmore, J. (1969) Regulation of insulin secretion. Pharmacological Reviews, 21(3), 183-212.
- 181 - Metz, R. (1960) The effect of blood glucose concentration on insulin output. Diabetes, 9, 89-93.
- 182 - Miller, R. E. & Whittenberger, J. L. (1968) Effect of vagotomy on venous insulin and glucose concentrations in the conscious monkey. Federation Proceedings, 27, 565.
- 183 - Milner, R. D. G. & Hales, C. N. (1968) Cations and the secretion of insulin. Biochimica et Biophysica Acta, 150, 165-167.
- 184 - ----- (1969) The interaction of various inhibitors and stimuli of insulin release studied with rabbit pancreas *in vitro*. Biochemical Journal, 113, 473-479.

- 185 - Mitchell, M. L. & Byron, J. (1967) Use of enzyme proteolysis for the immuno-chemical measurement of insulin. Diabetes, 16, 656-663.
- 186 - Montague, W. & Taylor, K. W. (1968) Regulation of insulin secretion by short-chain fatty acids. Nature, 217, 853.
- 187 - Moore, K. E., Calvert, D. N. & Brody, T. M. (1961) Tissue catecholamine content of cold-acclimated rats. Proceedings of the Society for Experimental Biology and Medicine, 106, 816-818.
- 188 - Morgan, C. R. & Lazarow, A. (1963) Immunoassay of insulin: two antibody system, plasma insulin levels of normal, sudiabetic and diabetic rats. Diabetes, 12, 115-126.
- 189 - Morris, G. E. & Korner, A. (1970) The effect of glucose on insulin biosynthesis by isolated islets of Langerhans in the rat. Biochimica et Biophysica Acta, 208, 404-413.
- 190 - Nathanielsz, P. W. (1969) Effects of cold (4°C) on catecholamine excretion in the diabetic rat and its relation to autonomic neuropathy. Diabetes, 18, 625-626.
- 191 - Nelson, N. C., Blachard, W. G., Cocchiara, J. C. & Labat, J. A. (1967) Influence of the vagus nerves on pancreatic insulin secretion. Diabetes, 16(12), 852-857.
- 192 - Norman, D., Pierguilio, M., Reid, D., Lester, G. & Hechter, O. (1959) Action of insulin on sugar permeability in rat diaphragm muscle. Journal of General Physiology, 42, 1277-1299.
- 193 - Norman, J. C. (1968) In Organ Perfusion and Preservation, ed. Norman, J. C., pp. 318, 539, 783, 912-914. New York: Appleton-Century-Crofts.

- 14)
- 194 - Nowell, N. W. & Howland, R. J. (1966) The control of blood sugar in the laboratory rat and golden hamster. I: Intravenous glucose tolerance and insulin sensitivity tests. Acta Endocrinologica, 149(153), 149-153.
- 195 - Okajima, F. & Ui, M. (1978) Adrenergic modulation of insulin secretion in vivo dependent on thyroid states. American Journal of Physiology, 234(2), E106-111.
- 196 - Pagé, E. & Chénier, L. P. (1953) Rev. Can. Biol., 12,530.  
(Cited by Depocas, 1960 b).
- 197 - Penhos, J., Wu, C. H., Basake, J., Lopez, N. & Wolff, F. (1969) A rat pancreas-small gut preparation for the study of intestinal factor(s) and insulin release. Diabetes, 18, 733-738.
- 198 - Pfeiffer, E. F., Fussganger, R., Hinz, M. & Raptis, S. (1970) Dynamics of insulin secretion: Comparison of various in vitro preparations. In The Structure and Metabolism of the Pancreatic Islets, ed. Falkmer, S., Hellman, B. & Taljedal, I.-B. pp. 423-443. Oxford: Pergamon Press.
- 199 - Pi-Sunyer, F. X., Campbell, R. & Hashim, S. A. (1970) Experimentally induced hyperketonemia and insulin secretion in the dog. Metabolism, 19, 263-270.
- 200 - Poe, R. H., White, J. W. & Davis, T. R. A. (1963) Alloxan-diabetic rats during acclimation to cold. American Journal of Physiology, 205(1), 184-188.
- 201 - Porte, D. jr., Graber, A.L., Kuzuya, T. & Williams, R. H. (1966) The effect of epinephrine on immunoreactive insulin levels in man. Journal of Clinical Investigation, 45, 228-236.
- 202 - Porte, D. jr. & Williams, R. H. (1966) Inhibition of insulin release by norepinephrine in man. Science, 152, 1248-1250.



- 203 - Porte, D.jr. (1967 a) A receptor mechanism for the inhibition of insulin release by epinephrine in man. Journal of Clinical Investigation, 46, 86-94.
- 204 - ----- (1967 b) Beta-adrenergic stimulation of insulin release in man. Diabetes, 16, 150-155.
- 205 - ----- (1969) Sympathetic regulation of insulin secretion. Its relation to diabetes mellitus. Archives of Internal Medicine, 123, 252-260.
- 206 - Porte, D.jr. & Pupo, A.A. (1969) Insulin response to glucose: evidence for a two pool system in man. Journal of Clinical Investigation, 48, 2309-2319.
- 207 - Porte, D.jr., Girardier, L., Seydoux, J., Kanazawa, Y. & Posternak, J. (1973) Neural regulation of insulin secretion in the dog. Journal of Clinical Investigation, 52, 210-214.
- 208 - Porte, D.jr. & Robertson, R. P. (1973) Control of insulin secretion by catecholamines, stress and sympathetic nervous system. Federation Proceedings, 32, 1792-1796.
- 209 - Potter, D. E., Wilson, L. M. & Ellis, S. (1977) Changes in plasma glucose and insulin levels induced by adrenergic agents in normal and alloxan-diabetic rats. Proceedings of the Society for Experimental Biology and Medicine, 154(3), 337-340.
- 210 - Raff, M. (1976) Self regulation of membrane receptors. Nature, 259, 265-266.
- 211 - Randle, P. J., Ashcroft, J. H. & Gill, J. R. (1968) Carbohydrate metabolism and release of hormones. In Carbohydrate Metabolism and its Disorders, ed. Dickens, F., Randle, P. J. & Whelan, W. J. Volume 1, pp. 427-447. London: Academy Press.

- 213 - Rasmussen, H. & Tenenhouse, A. (1968) Cyclic adenosine monophosphate,  $Ca^{++}$  and membranes. Proceedings of the National Academy of Science (US), 59, 1364-1370.
- 214 - Robertson, R. P. & Porte, D. jr. (1974) Plasma catecholamine responses to intravenous glucose in normal man. Journal of Clinical Endocrinology and Metabolism, 39, 403.
- 215 - Rosenberg, M. D. (1971) Discrimination among dispersion forces at the aqueous-fluorocarbon interface. Federation Proceedings, 30, 1623-1630.
- 216 - Ross, B. D. (1972) In Perfusion Techniques in Biochemistry, ed. Ross, B. D., pp. 23, 41-62, 85-87. Oxford: Clarendon Press.
- 217 - Roy, M. L., Sellers, E. M., Flattery, K. V. & Sellers, E. A. (1977) Influence of cold exposure and thyroid hormones on regulation of adrenal catecholamines. Canadian Journal of Physiology and Pharmacology, 55, 804-812.
- 218 - Sacca, L., Perez, G., Carteni, G. & Rengo, F. (1977) Evaluation of the role of the sympathetic nervous system in the glucoregulatory response to insulin-induced hypoglycemia in the rat. Endocrinology, 101, 1016-1022.
- 219 - Salvador, R. A., April, S. A. & Lemberger, L. (1968) Phentolamine activation of glycogenolysis in rat skeletal muscle. Biochemical Pharmacology, 17, 395-402.
- 220 - Salzman, E. W., Chambers, D. A. & Neri, L. L. (1966) Possible mechanism of aggregation of blood platelets by adenosine diphosphate. Nature (London), 210, 167-169.
- 221 - Samols, E. G., Marri, G. & Marks, V. (1965) Promotion of insulin secretion by glucagon. The Lancet, 2, 415-416.

- 222 - ----- (1966) Inter-relationship of glucagon, insulin and glucose. Insulinogenic effect of glucagon. Diabetes, 15, 855-866.
- 223 - Sellers, E. A., Flattery, K. V., Shum, A. & Johnson, G. E. (1971) Thyroid status in relation to catecholamines in cold and warm environment. Canadian Journal of Physiology and Pharmacology, 49, 268-275.
- 224 - Seyffert, W. A. & Madison, L. L. (1967) Physiological effects of metabolic fuels on carbohydrate metabolism. I: Acute effect of elevation of plasma free fatty acids on hepatic glucose output, peripheral glucose utilization, serum insulin, and plasma glucagon levels. Diabetes, 16, 369-376.
- 225 - Shorr, S. S. & Bloom, S. E. (1970) Fine structure of islet-cell innervation in the pancreas of normal and alloxan-treated rats. Zeitschrift Zellforsch, 103, 12-25.
- 226 - Shum, A., Johnson, G. E. & Flattery, K. V. (1969) Influence of ambient temperature on excretion of catecholamines and metabolites. American Journal of Physiology, 216, 1164-1169.
- 227 - Sloviter, H. A. & Kamimoto, T. (1967) Erythrocyte substitute for perfusion of brain. Nature, 216, 458-460.
- 228 - Smith, R. E. (1962) Cold-acclimation; an altered steady state. JAMA, Clinical Science, 179(12), 110-116.
- 229 - Smith, R. E. & Horwitz, B. (1969) Brown fat and thermogenesis. Physiological Reviews, 49, 330-425.
- 230 - Snyder, P. J., Kashket, S., & O'Sullivan, J. B., (1970) Pentose cycle in isolated islets during glucose-stimulated insulin release. American Journal of Physiology, 219, 876-880.
- 231 - Steiner, D., F., Cunningham, D. D., Spigelman, L & Alten, B. (1967) Insulin biosynthesis: evidence for a precursor. Science, 157, 697-700.

- 232 - Sumi, T., & Ui, M. (1975) Potentiation of the adrenergic beta-receptor-mediated insulin secretion in pertussis-sensitized rats. Endocrinology, 97, 352-358.
- 233 - Sussman, K. E., Vaughan, G. N. & Timmer, R. (1966) An in vitro method for studying insulin secretion in the perfused isolated rats pancreas. Metabolism, 15, 466-476.
- 234 - Sussman, K. E. & Vaughan, G. D. (1967) Insulin release after ACTH, glucagon, and adenosine-3'-5'-phosphate (cyclic AMP) in the perfused isolated rat pancreas. Diabetes, 16, 449-454.
- 235 - Tanese, T., Lazarus, N. R., Devrim, S. & Recant, L. (1970) Synthesis and release of proinsulin and insulin by isolated rat islets of Langerhans. Journal of Clinical Investigation, 49, 1394-1404.
- 236 - Toomey, R. E., Show, W. N., Reid, L. R. & Young, W. K. (1970) Comparative study of the effects of porcine proinsulin and insulin on lipolysis and glucose oxidation in rat adipocytes. Diabetes, 19, 209-\_\_\_\_\_.
- 237 - Turtle, J. R. & Kipnis, D. M. (1967 a) An adrenergic receptor mechanism for the control of cyclic 3'-5'-adenosine monophosphate synthesis in tissue. Biochemical and Biophysical Research Communications, 28, 797-802.
- 238 - ----- (1967 b) Stimulation of insulin secretion by theophylline. Nature (London), 213, 727-730.
- 239 - Udenfriend, S. (1968) Physiological regulation of noradrenaline biosynthesis. CIBA Foundation, Study Group No. 33, 3-11.
- 240 - Unger, R. H., Ketterer, H., Dupre, J. & Eisentraut, A. M. (1967) The effects of secretin, pancreozymin and gastrin on insulin and glucagon secretion in anaesthetized dogs. Journal of Clinical Investigation, 46, 630-645.

- 241 - Vance, J. E., Buchanan, K. D., O'Hara, D., Williams, R. H. & Porte, D. jr. (1969) Insulin and glucagon responses in subjects with pheochromocytoma: effect of alpha-adrenergic blockade. Journal of Clinical Endocrinology, 29, 911-916.
- 242 - Vendsalu, A. (1960) Studies on adrenaline and noradrenaline in human plasma. Acta Physiologica Scandinavica Suppl. 173.
- 243 - Werrback, J. H., Gale, L. C., Goodner, C. J. & Conway, M. J. (1970) Effects of autonomic blocking agents on growth hormone, insulin, free fatty acids and glucose in baboons. Endocrinology, 86, 77-82.
- 244 - Wide, L. & Porath, J. (1966) Radioimmunoassay of proteins with the use of Sephadex-coupled antibodies. Biochimica et Biophysica Acta, 130, 257-260.
- 245 - Wolf, M. M. & Berne, R. M. (1956) Coronary vasodilator properties of purine and pyrimidine derivatives. Circulation Research (N.Y.), 4, 343.
- 246 - Woods, S. C. & Porte, D. jr. (1974) Neural control of the endocrine pancreas. Physiological Reviews, 54, 596-619.
- 247 - Wright, P. H. & Malaisse, W. J. (1968) Effects of epinephrine, stress and exercise on insulin secretion by the rat. American Journal of Physiology, 214, 1031-1034.
- 248 - Wright, P. H., Makulu, D. R., Malaisse, W. J., Roberts, M. N. & Yu, P. Y. (1968) A method for the immunoassay of insulin. Diabetes, 17, 537-546.
- 249 - Yajima, M., Hosokawa, T. & Ui, M. (1977) An involvement of alpha-adrenergic stimulation in exercise-induced hypoglycemia. European Journal of Pharmacology, 43(1), 1-9.

250 - Yalow, R. S. & Berson, S. A. (1960). Immunoassay of endogenous plasma insulin in man. Journal of Clinical Investigation, 39, 1157.

251 - Zaharko, D. S. & Beck, L. V. (1968) Studies for a simplified plasma insulin immunoassay using cellulose powder. Diabetes, 17, 444-457.

Further Relevant References not cited in the Text

- 1 - Andersson, A. (1974) Long-term effects of glucose on insulin release and glucose oxidation by mouse pancreatic islets maintained in tissue culture. Biochemical Journal, 140(3), 377-382.
- 2 - Baird, J. R. C. & Carter, A. J. (1974) Assessment of effects of beta-blocking drugs on blood glucose levels and insulin hypoglycaemia in rats. European Journal of Pharmacology, 25(2), 275-278.
- 3 - Brodie, B. B., Costa, E., Dlabac, A., Nefe, N. H. & Smookler, H. H. (1966) Application of steady state kinetics to the estimation of synthesis rate and turnover time of tissue catecholamine. Journal of Pharmacology and Experimental Therapeutics, 154.
- 4 - Chang, K.-J. & Cuatrecasas, P. (1974) Adenosine triphosphate-dependent inhibition of insulin-stimulated glucose transport in fat cells; possible role of membrane phosphorylation. Journal of Biological Chemistry, 249(10), 3170-3180.
- 5 - Charbon, G. A. (1961) The influence of the vagus nerves on the blood sugar level. Acta Physiologica et Pharmacologica, 10, 119-135.
- 6 - De Jong, A., Strubbe, J. H. & Steffens, A. B. (1977) Hypothalamic influence on insulin and glucagon release in the rat. American Journal of Physiology, 233(5), E380-E388.
- 7 - Depocas, F. & Behrens, W. A. (1976) Effects of handling, decapitation anaesthesia and surgery on plasma noradrenaline levels in the white rat. Canadian Journal of Physiology and Pharmacology, 55, 212-219.

- 8 - Eaton, R. P., Kipnis, D., Karl, I. & Eisenstein, A. (1974) Effects of glucose feeding on insulin and glucagon secretion and hepatic gluconeogenesis in the rat. American Journal of Physiology, 227(1), 101-104.
- 9 - Felts, J. M. & Masoro, E. J. (1959) Effects of cold-acclimation on hepatic carbohydrate and lipid metabolism. American Journal of Physiology, 197, 34-36.
- 10 - Forichon, J., Jomain, M. J., Patricot, M. C. & Minaire, Y. (1977) Tolerance to cold and glucose homeostasis in adrenal-demedullated dogs. Experientia, Suisse, 33(8), 1070-1072.
- 11 - Frankel, B., Gerich, J., Hagura, R., Fauska, R., Gerritsen, G. & Grodsky, G. (1974) Abnormal secretion of insulin and glucagon by the in vitro perfused pancreas of genetically diabetic chinese hamster. Journal of Clinical Investigation, 53(6), 1637-1646.
- 12 - Jarrett, R. J. & Keen, H. (1966) Glucose metabolism of isolated mammalian islets of Langerhans. The Lancet, 1, 633-635.
- 13 - ----- (1968) Oxidation of sugars, other than glucose, by isolated mammalian islets of Langerhans. Metabolism, 17, 155-157.
- 14 - Johnson, D. G., Hayward, J. S., Jacobs, T. P., Collis, M. L., Echerson, J. & Williams, R. H. (1977) Plasma noradrenaline responses of man in cold water. Journal of Applied Physiology (U.S.A.), 43(2), 216-220.
- 15 - Klain, G. J. & Burlington, R. F. (1967) Effect of cold in glucose metabolism of fasted and fasted-refed rats. American Journal of Physiology, 213, 209-214.
- 16 - Klain, G. J. & Hannon, J. P. (1969) Gluconeogenesis in cold-exposed rats. Federation Proceedings, 3, 965-968.



17. - Kosaka, K., Kaneto, A., Ide, T., Fukuchi, S., Kuzuya, T. & Okinaka, S. (1964) Effect of stimulation of the cerebellum on insulin secretion. Endocrinology, 74, 361-365.
- 18 - Loubatières, A., Mariani, M. M. & Chapal, J. (1970) Etude, sur le pancreas isole et perfuse du rat, de l'action des recepteurs cholinergiques sur l'insulin-secretion. Comptes Rendus des Seances-Societe de Biologie, 164(2), 2345.
19. - Malaisse, W. F., Malaisse-Lagae, F., McGraw, E. F. & Wright, P. H. (1967) Insulin secretion in vitro by pancreatic tissue from normal, adrenalectomized and cortisol treated rats. Proceedings of the Society for Experimental Biology and Medicine, 124, 924-928.
- 20 - Masoro, E. J., Cohen, A. I. & Panagos, S. S. (1954) Effect of exposure to cold on some aspects of hepatic acetate utilization. American Journal of Physiology, 179, 451-456.
- 21 - Masoro, E. J., Porter, E. & Patkin, J. (1960) Effect of cold stress lipogenesis by adipose tissue. American Journal of Physiology, 198, 1123-1125.
- 22 - Masoro, E. J. (1966) Effect of cold on metabolic use of lipids, Physiological Reviews, 46, 67-101.
- 23 - Muirhead, M., Inglis, A & Himms-Hagen, J. (1974) Urinary excretion of cyclic AMP by cold-acclimated rats. Canadian Journal of Biochemistry, 52(5), 414-417.
- 24 - Nowell, N. W. & White, D. C. (1963) Seasonal variation of magnesium and calcium in serum of the hypothermic rat. Journal of Applied Physiology, 18(5), 967-969.
- 25 - Penner, P. E. & Himms-Hagen, J. (1968) Gluconeogenesis in rats during cold-acclimation. Canadian Journal of Biochemistry, 46, 1205-1213.

- 26 - Popper, C. W., Chiueh, C. C. & Kopin, I. J. (1977) Plasma catecholamine concentration in unanaesthetized rats during sleep, wakefulness, immobilization and after decapitation. Journal of Pharmacology and Experimental Therapeutics, 202(1), 144-148.
- 27 - Robertson, R. P. & Port E.D.jr. (1973) The glucose receptor; a defective mechanism in diabetes mellitus distinct from the beta-adrenergic receptor. Journal of Clinical Investigation, 52, 870-876.
- 28 - Roizen, M. F., Weise, V., Moss, J. & Kopin, I. J. (1976) Plasma catecholamines: arterial-venous differences and the influence of body temperature. Life Sciences, 16, 1133-1144.
- 29 - Roizen, M. F., Moss, J., Henry, D. P., Weisse, V. & Kopin, I. J. (1978) Effect of general anaesthetics on handling- and decapitation-induced increases in sympatho-adrenal discharges. Journal of Pharmacology and Experimental Therapeutics, 204(1), 11-18.
- 30 - Sawin, C. T. (1969) The sympathetic nervous system and the adrenal medulla. In The Hormones, ed. Sawin, C. T. pp. 79-91. Boston: Little-Brown.
- 31 - Shabaan, A., Turner, D. S. & Marks, V. (1974) The effect of adrenaline on insulin releasing polypeptide (IRP) mediated insulin release in vivo in the rat. Diabetologia, 10, 475-478.
- 32 - Sladek, C. D. & Snarr, J. F. (1974) Concentration-dependent inhibition of hepatic gluconeogenesis by insulin. Proceedings of the Society for Experimental Biology and Medicine, 146(1), 194-199.

- 33 - Starr, J. I. & Rubenstein, A. H. (1975) Insulin, Pro-insulin and C-peptide. Academic Press Publications, pp. 289-315.
- 34 - Wunder, B. A., Dobkin, D. S. & Gettinger, R. D. (1977) Shifts of thermogenesis in the prairie vole Microtus ochrogaster strategies for survival in a seasonal environment. Oecologia-Allemanica, 29(1), 11-26.

## APPENDICES

Appendix 1

Schematic diagram of the screen-cylinder oxygenator

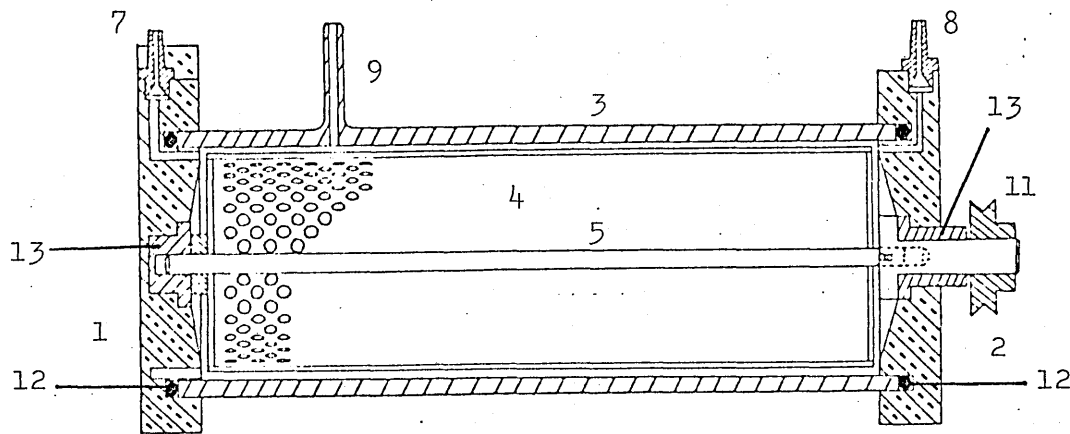

Side View

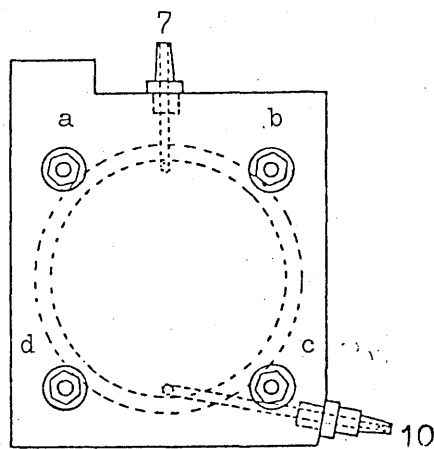

end plate 1

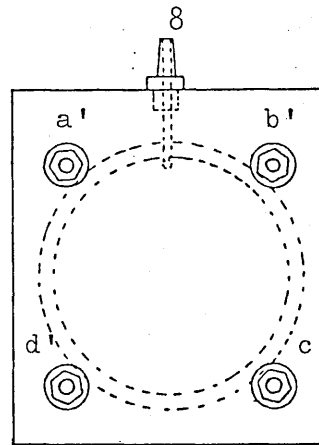

end plate 2

Key to numbers:

- 1 - Perspex end plate 1.
- 2 - " " end plate 2.
- 3 - " " cylinder jacket.
- 4 - Screen cylinder, pore size: 3 mm diameter.
- 5 - Stainless steel shaft.
- 6 - aa', bb', cc', dd': four metal nuts placed at the ends of threaded rods.

- 7 - Gas inlet.
- 8 - Gas outlet.
- 9 - Perfusate inlet.
- 10 - Perfusate outlet.
- 11 - Brass pulley.
- 12 - Rubber O-ring seals.
- 13 - Stainless steel bearing, of the shaft.

Scale 1:2.26

100

Appendix 2

Temperature Meter Unit

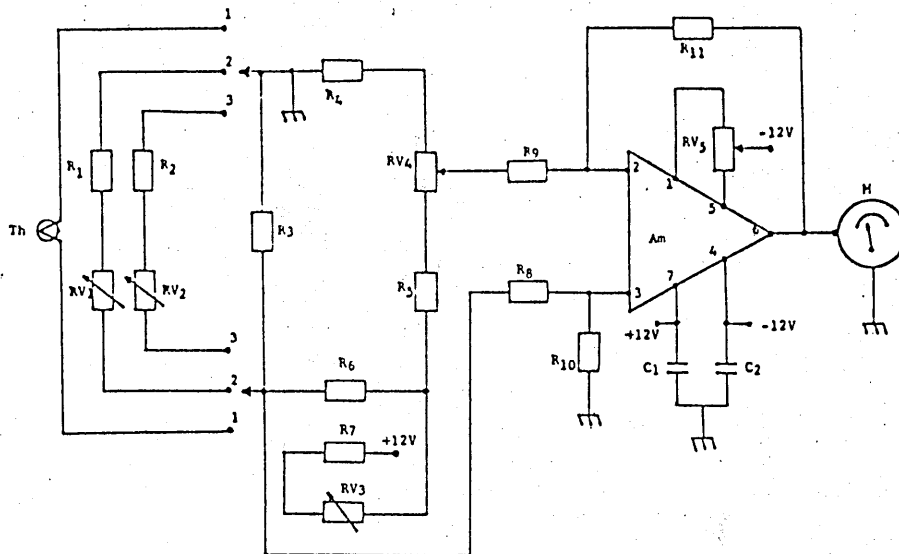

Components list:

$R_{1,3} = 1K2, \frac{1}{2}W, 2\%$ , metal oxide.

$R_2 = 820, \text{ " " " "}$

$R_{4,5} = 470, \text{ " " " "}$

$R_6 = 560, \text{ " " " "}$

$R_7 = 1K5, \text{ " " " "}$

$R_{8,9} = 10K0, \text{ " " " "}$

$R_{10,11} = 27K0, \text{ " " " "}$

$RV_{1,4} = 200, \text{ Lin. carbon}$

$RV_2 = 500, \text{ " "}$

$RV_3 = 5K0, \text{ " "}$

$RV_5 = 10K0, \text{ " "}$

$C_{1,2} = 0.01Z$

Th=Glass bead thermister  
RS-151-029.

Am=Amplifier, 4131T, R.S.

M =Ammeter(100 $\mu$  amps) to  
read 30-40 C in 0.1 units.

Case 2 piece metal case.

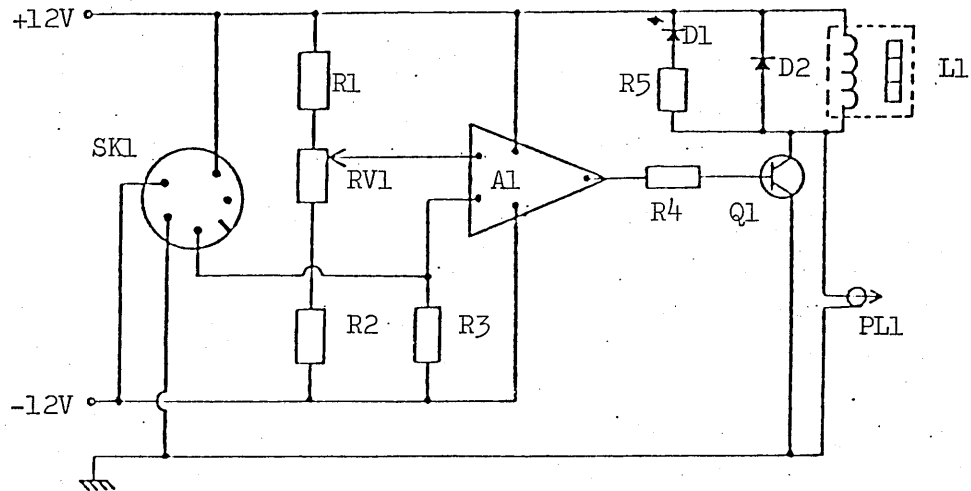
Drop Counter Control Unit

## Components list:

- D1 Min LED indicator, red.  
 D2 1N4148.  
 A1 741 op Amp.  
 Q1 2N3053 s.l., NPN.  
 R1,2 2K7,  $\frac{1}{2}$ w, 2%, metal oxide.  
 R3 3K9,  $\frac{1}{2}$ w, 2%, metal oxide.  
 R4 5K6,  $\frac{1}{2}$ w, 2%, metal oxide.  
 R5 1K0,  $\frac{1}{2}$ w, 2%, metal oxide.  
 RV1 5K0, Lin. carbon.  
 L1 Veeder Root K.J. 1643.  
 SK1 DIN 5-240 socket.  
 PL1 3.5 mm Jack Plug.  
 Case 2 piece metal case.

100  
Appendix 4

Oxygen Dissociation Curve of FX-80

This section presents the details of the oxygen dissociation curve of FX-80 (Perfluoro-2-butyl tetrahydrofuran, ICN Pharmaceuticals Inc.) suspended in Krebs-Henseleit bicarbonate medium by ultrasonic disintegration. The FX-80 suspensions were equilibrated with different oxygen percentages in gas mixtures with constant  $P(\text{CO}_2) = 35.65$  mmHg, for 20 min. each at a fixed temperature  $37^\circ\text{C}$ . Analyses of total oxygen content of 2 ml samples were done by the Van Slyke method. Percentage saturations of oxygen, at the different partial pressures of oxygen used, were calculated and listed in the following table:

Sample	% O <sub>2</sub> in gas phase	P(O <sub>2</sub> ) in gas phase	ml O <sub>2</sub> /2 ml perfusate	ml O <sub>2</sub> /100 ml perfusate at s.t.p.
A	2.2	15.5	0.17	7.7
B	3.8	26.7	0.64	28.9
C	5.4	38.0	0.82	37.0
D	6.6	46.4	0.95	42.8
E	8.3	58.3	1.06	47.8
F	21.8	153.2	1.12	50.5
G	40.3	283.2	1.12	50.5

