

GEOMETRICAL ASPECTS OF THE AZEOTROPIC LIQUID-LIQUID- VAPOUR PHASE EQUILIBRIA

J.A. Labarta*, M.M. Olaya, A. Gómez and A. Marcilla

Dpto. Ingeniería Química, Universidad de Alicante, Apdo. 99, Alicante 03080, Spain.

Abstract

The ternary isobaric liquid-liquid-vapour and liquid-vapour equilibrium can be very complex and may present a wide variety of three-dimensional representations, which sometimes are not very well understood. This paper presents several examples of possible complex spatial behaviours with different kind of azeotropes. These examples have been selected to clarify the expected projections deduced from the binaries and to help in the understanding of these type of equilibrium as well as in the experimental data determination and interpretation.

Keywords: Graphical representations; azeotropic, equilibrium;

1.- Introduction

The graphical representation of the phase equilibrium is a powerful tool in the understanding of the concepts involved in this type of problems and calculations. This tool is widely and correctly used for binary systems, but for ternary and obviously for higher order systems, the situation is not the same. There are some difficulties inherent to the representation of three-dimensional objects, specially when the surfaces involved are complex and intersect each other in curved shapes due to the presence of different kind of azeotropes. Three-dimensional plots are frequently used, but sometimes and probably due to this difficulty in drawing and interpreting them, the figures are oversimplified only presenting the lines that authors need to remark. Thus, other regions in the figures presented are ambiguous

* Author to whom all correspondence should be addressed. Tel.: (34) 965 903 789. Fax: (34) 965 903 826. E-mail: ja.labarta@ua.es

or undefined. Unfortunately, in other cases, errors in the shape or relative position of the important lines or surfaces have been detected in the literature, contributing to the misunderstanding of the equilibrium behaviour. The construction and drawing of such diagrams must be done with care, showing all the equilibrium regions and boundaries with feasible shapes, from the binaries and azeotropic points. Graphical representations done in this way are a useful tool for a systematic study of this type of systems and to obtain valuable experimental data covering all the equilibrium regions. Long time ago, Marsch^[1] said: “erroneous diagrams have appeared because the constructor failed to observe the rules of construction”. Probably due to these reasons the two-dimensional projections are preferred.

The qualitative shape of ternary temperature/composition or enthalpy/composition diagrams in azeotropic systems is not obvious and requires careful thinking and a spatial view. Once they are understood, they definitely help the understanding of the behaviour of the system and the selection of the samples in order to fully and systematically determine all the regions involved in the equilibrium. If graphical representations are not considered serious errors can be made.

The complexity and variety of possible behaviours of the ternary azeotropic liquid-vapour equilibrium are very high. Thus, instead of trying to be extensive in the description of such behaviours, we will show several examples where some selected behaviours are explained in detail. We will provide different projections as well as three-dimensional qualitative representations of the different surfaces and boundaries of the system, which are expected from the behaviour of the corresponding binaries. Finally, we will comment on the importance of the qualitative knowledge of the behaviour of these azeotropic systems both for the selection of the experimental methodology for equilibrium data determination and for process synthesis, design and equilibrium modelling.

2.- Azeotropic liquid-liquid-vapour and liquid-vapour equilibrium

The knowledge of the structure and properties of liquid-vapour and liquid-liquid-vapour phase diagrams for ternary systems is especially interesting for the study of the distillation processes, particularly for the homogeneous and heterogeneous azeotropic distillation. In recent years, many authors have studied the use of the distillation curve maps for the determination of separations feasible by distillation^{[2]-[8]}. These distillation curve maps as well as the boundary lines for the distillation regions can be more easily understood if the three-dimensional qualitative form of the temperature-composition diagram is known. On the other hand, equilibrium data are necessary because equilibrium calculations required for rating or designing the equipment for separation processes use the thermodynamic models with binary parameters obtained from experimental data. However, there are little experimental data available, and these do not include all the possible range of composition^{[9]-[13]}. If the experimental data obtained are grouped in a restricted zone of the phase diagram, the parameters obtained will only be useful in that region, and extrapolation must be done with care. Graphical representations can be useful to obtain the experimental data homogeneously distributed in the overall composition range, searching for data in all the possible regions.

Nevertheless, a difficulty exists for the qualitative representation (and interpretation) of the temperature-composition diagrams for azeotropic liquid-vapour and liquid-liquid-vapour ternary systems, related to the inherent difficulty of representing three-dimensional objects, which gets worse due to the complex shape of the equilibrium surfaces. All these facts have the consequence that, sometimes, the diagrams reported appear incomplete and not very clearly explained.

The possibility of finding different kinds of azeotropic systems is large^[14]. As examples, some types can be referred to:

- 1.- One binary azeotrope of minimum temperature (BAmin): e.g. Ethanol-Water-Acetic Acid.
- 2.- One binary azeotrope of maximum temperature (BAMax) and one saddle ternary azeotrope (TA): e.g. Water-Formic acid-Acetic Acid.
- 3.- Two BAmin, e.g. Ethanol-Water-n-Butanol.
- 4.- Two BAMax and one ternary azeotrope of maximum temperature (TAMax), e.g. Hydrogen Fluoride-Hexafluorosilicic Acid-Water.
- 5.- Two BA: one BAMax and one BAmin, e.g. Butanol- Acetic Acid-Butyl acetate.
- 6.- Two BA: one BAMax and one BAmin, and one TA saddle, e.g. n-Butylamine-Ethanol-Water.
- 7.- Three BAmin, e.g. Butanol-Butyl Acetate-Dibutyl Ether.
- 8.- Three BAmin and one ternary azeotrope of minimum temperature (TAmin) (homogeneous or heterogeneous), e.g. (homogeneous): Methane,Trichloro-Ethanol-Hexane; 2-Propanone-Methanol-Acetic Acid, Methyl ester; Benzene-Cyclohexane-2-Propanol. E.g. (heterogeneous): 2-Propanol-Water-Benzene; Ethanol-Water-Cyclohexane. E.g. (homogeneous with miscibility gap): Ethanol-Acetic Acid, Ethyl Ester-Water; 2-Propanone-Methanol-Cyclohexane ($T < 323$ K); 2-Propanol-Water-Methane, Nitro.
- 9.- Three BA: two BAmin and one BAMax, and one saddle TA, e.g. 2-Propanone-Methane,Trichloro-Methanol; 2-Propanone- Methane, Trichloro-Hexane.
- 10.- Three BA: two BAmin and one BAMax, and one node (not minimum and not maximum) TA, e.g. Ethane,1,2-Dichloro-Water-Formic Acid

3.- Graphical representation of ternary azeotropic systems

In this section we will try to qualitatively illustrate, as examples, the general shape of the temperature-composition diagrams for the liquid-vapour and liquid-liquid-vapour equilibrium in the following ternary azeotropic systems:

- a) One heterogeneous binary azeotrope of minimum temperature, for a system with two components partially miscible.
- b) Three binary azeotropes of minimum temperature (two homogeneous and one heterogeneous) and one minimum homogeneous ternary azeotrope, for a system with two components partially miscible.
- c) Three binary azeotropes (two BA_{min} and one BA_{Max}) and one saddle homogeneous TA.
- d) Three minimum homogeneous binary azeotropes and one ternary azeotrope of minimum temperature.
- e) Three binary azeotropes (two BA_{min} and one BA_{Max}) and one homogeneous node TA of intermediate temperature.
- f) One BA_{Max} and one saddle TA.

For this purpose, several three-dimensional figures have been constructed (Figures 1-5). For examples in Figures 1 and 2, we also show with more detail the different zones of the liquid-liquid-vapour equilibrium, separating their different limiting surfaces (Figures 1b and 2b). In the case 2, the projections on different planes (isothermal and constant composition planes) are also presented in one case (Figure 2c).

Figure 1a shows the liquid-liquid-vapour phase diagram for a ternary system corresponding to the first case with one BA_{min} (heterogeneous, BA₁₂). We can see the detail of all the different regions for the ternary equilibrium diagram: two partially miscible liquids, two partially miscible liquids with their saturated vapour (vapour line) and one liquid with the corresponding vapour in equilibrium. PP is the plate point and LV is the point at the end of

the vapour line, being connected by a horizontal tie line. The vapour line starts at BA_{12} , (heterogeneous binary azeotrope) and ends at LV, lengthways the saturated vapour surface.

Figure 1b shows all the different surfaces limiting the different equilibrium regions. In this way the L-L, the L-L-V and the L-V region have been separated.

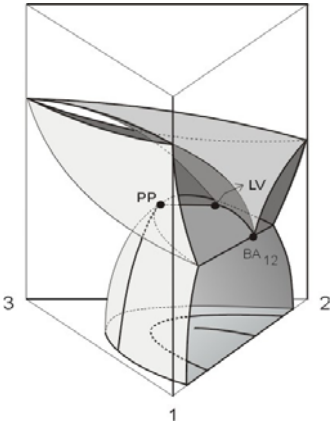

Figure 1a. Temperature-composition diagram of a liquid-liquid-vapour ternary system with one heterogeneous azeotrope.

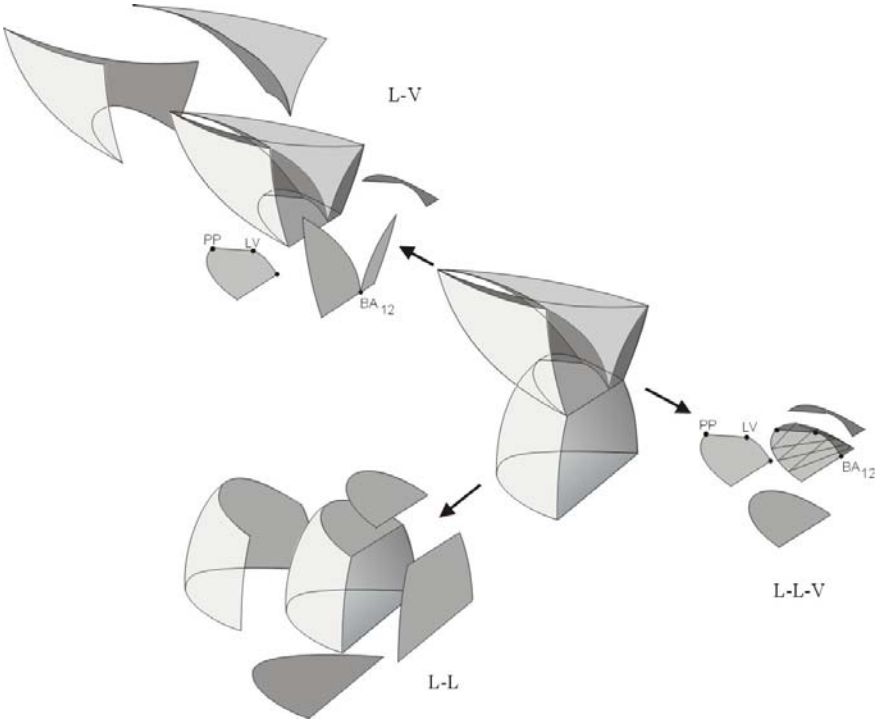

Figure 1b. Different zones and surfaces in the ternary phase diagram from Figure 1a.

Figure 2a shows the liquid-liquid-vapour phase diagram for a ternary system with three binary azeotropes of minimum temperature (two homogeneous, BA_{23} and BA_{13} , and one heterogeneous, BA_{12}) and one minimum homogeneous ternary azeotrope (TA). As can be seen, the saturated vapour surface connects with the surface corresponding to the boiling liquid surface at TA, out of the heterogeneous liquid mixtures zone. Applying the procedure proposed by Foucher et al.^[12] and shown by Seader & Henley^[13], in this diagram there are three boundaries: from the homogeneous binary azeotropes to the ternary azeotrope and from the ternary azeotrope to the heterogeneous binary azeotrope, dividing the overall liquid-vapour and liquid-liquid-vapour equilibrium region into three distillation zones.

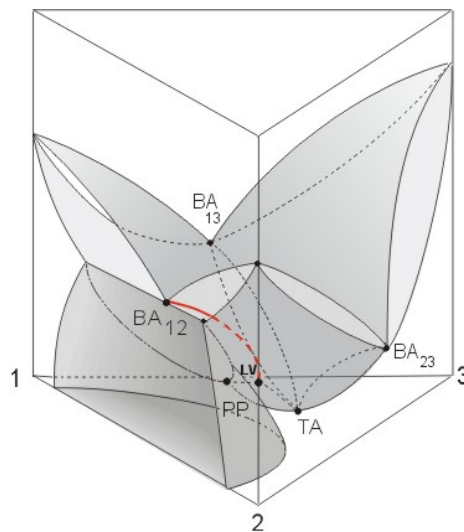

Figure 2a. Temperature-composition diagram of a liquid-liquid-vapour ternary system with three binary azeotropes (two homogeneous, BA_{23} and BA_{13} , and one heterogeneous, BA_{12}) and one homogeneous minimum ternary azeotrope (TA).

Figure 2b shows five zones of the same phase diagram (3 BAmin and 1 TAmin) which have been separated in order to clarify the characteristics of the diagram: the lower zone corresponds to the heterogeneous two-liquid region (components 1 and 2 partially miscible) and their upper limit is the boiling heterogeneous liquid surface (BA_{12} -PP). The second zone corresponds to the liquid-liquid-vapour region and it has as the lower limit, the previous surface (BA_{12} -PP) and as the upper limit, the surface defined by the side of the tie triangles

that connect the two liquid phases and their equilibrium vapour in the vapour line BA_{12} -LV. These tie triangles are horizontal (constant temperature) and the vapour line is a curve contained in the saturated vapour surface. Finally, the upper zone corresponds to the liquid-vapour region. This zone can be divided according to Foucher et al.^[12] or Safrit and Westerberg^[5], into three new regions (Component 1- BA_{12} -TA- BA_{13} , Component 2- BA_{12} -TA- BA_{23} and Component 3- BA_{23} -TA- BA_{13}) separated by the three boundary surfaces that exist in this case, between the ternary azeotrope and the two homogeneous binary azeotropes (BA_{13} -TA and TA- BA_{23}), and between the ternary azeotrope and the heterogeneous binary azeotrope (BA_{12} -TA) in agreement with the valleys and ridges on the boiling point (or the dew point) surface.

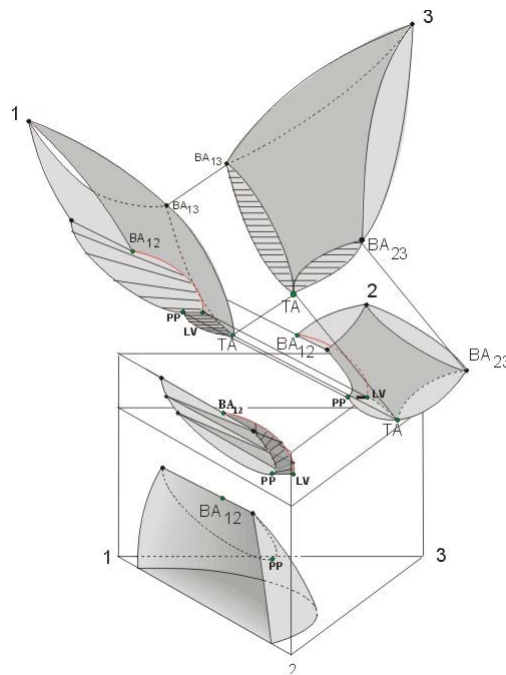

Figure 2b. Separation in different sectors in the temperature-composition diagram shown in Figure 2a (liquid-liquid-vapour ternary system with three binary azeotropes, and one minimum homogeneous ternary azeotrope).

Figure 2c presents the projections on the isothermal planes and the constant composition planes, showing the different zones in each case. Figures 2c2, 2c3 and 2c4 show complex behaviour of the liquid-liquid-vapour equilibrium. It is evident that if the researcher is not

aware of possible existence of these different regions in the equilibrium diagram they are difficult to find or to locate unless casually. In other words, it may be possible to report as a phase equilibrium diagram for a system at a given temperature only the data corresponding to the liquid-liquid equilibrium (i.e. the region L-L in figure 2c2) if the researcher works in this field, or only the region corresponding to the L-V equilibrium if the researcher is working in that area. Very rarely are reported complete sets of data as those needed to fully describe figures of the type shown in figure 2. This practice may have two important consequences:

i) The first one is related to the methodology for obtaining experimental data and situations as those reported for the or liquid-liquid-solid equilibrium^{[15],[16]}, where we have detected different mistakes, systems ambiguously reported or incompletely studied with misleading equilibrium regions. This type of problems can be easily avoided when considering the three-dimensional representation of the equilibrium.

ii) The second aspect may have other type of consequences, and we would like only to mention them in this paper. When correlating the experimental data with any activity coefficient model, multiple solutions can be obtained. A lot of literature dealing on this topic has been written. Many authors correlate single sets of experimental data and a wide variety of parameters can be found for the same system under the same or similar conditions. The variation of the parameters with the temperature has also merit a lot of attention and other authors simultaneous correlate liquid-liquid data with liquid-liquid-vapour data. In other words, it is possible (as in the case of liquid-liquid and liquid-liquid-solid equilibrium)^[16] that a set of parameters reported for a given system would not be capable of reproduce all the equilibrium regions of the system, even at the same temperature where they were obtained, and simply because the system was not studied experimentally in a systematic way. Nevertheless, no attempt has been found in the literature where a complete set of experimental data covering systematically all the equilibrium regions had been correlated by any model.

We believe that the parameters in that way obtained would have more foundations and would represent more adequately the system (as in the case of liquid-liquid-solid equilibrium^[17]). This practice would be of enormous interest in selecting the best set of parameters and their variation with temperature. Also we have note that the best parameters would also provide the simplest way of variation of the Gibbs energy/composition surfaces capable of explaining the behaviour of phase splitting of the system, and this criterion would be used for selecting them.

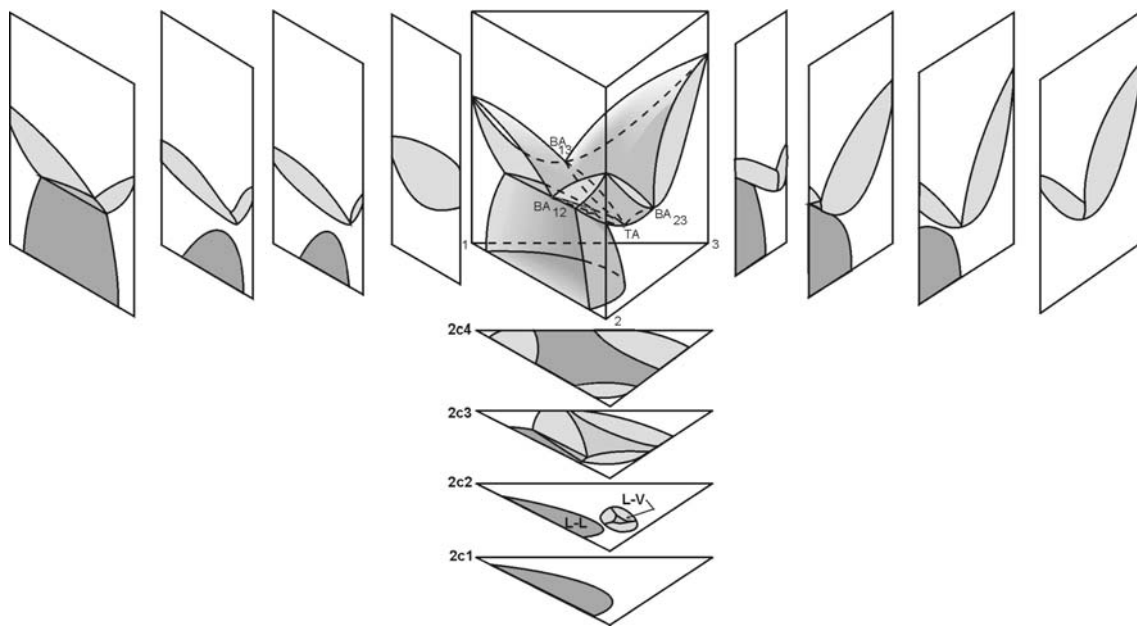

Figure 2c. Different cuts along the three axes (isothermal and constant composition planes) in the temperature-composition diagram shown in Figure 2a (liquid-liquid-vapour ternary system with three binary azeotropes, and one minimum homogeneous ternary azeotrope).

In general, in the case of liquid-liquid-vapour equilibrium (Figures 1-2) we can find the following characteristics:

1.-) One surface (generally not planar but ruled), resulting from the intersection between the saturated liquid surface and the two liquids solubility surface, that contains the points representative of the heterogeneous liquid mixtures at their bubble point. The two liquid phases from each heterogeneous mixture are located at the ends of the corresponding tie line (horizontal, since the temperature is constant), and in the binodal curve that limits the

mentioned surface. The representative point of the vapour in equilibrium with these two liquids is located in the so-called vapour line (BA_{12} -LV). This surface divides the liquid-liquid region from the liquid-liquid-vapour region.

2.-) The vapour line (geometrical location of the points representative of the vapour in equilibrium with the heterogeneous liquid mixtures) starts in the binary heterogeneous azeotrope, BA_{12} , and continues in the saturated vapour surface (it is not a straight line). The contact between the saturated vapour surface and the saturated liquid is produced at the pure components and at the azeotropes. In the case of existence of a ternary azeotrope (TA), this can be out (case b, Figure 2) or within of the heterogeneous liquid mixture zone.

3.-) The last point of the vapour line (LV) corresponds to a vapour in equilibrium with the liquid whose composition is that of the plate point (PP). Therefore, there is a tie line (horizontal) connecting these two points.

4.-) Along the vapour line, and for all the points between the BA_{12} and LV, tie triangles can be built connecting the three representative points of the three phases in equilibrium (two liquids on a tie line on the binodal curve and the vapour, in equilibrium with them, on the vapour line). Therefore, these triangles are also horizontal (constant temperature, Figure 1b and 2b).

5.-) If the system has an heterogeneous ternary azeotrope, the vapour line would intersect to the heterogeneous liquid boiling surface at the point corresponding to the ternary azeotrope composition. In this case the vapour line has two different sections: from the binary azeotrope to the ternary azeotrope and from the ternary azeotrope to the end of the vapour line.

6.-) Boundary surfaces having an extraordinary importance can be distinguish, although they do not correspond to equilibrium surfaces, separating different equilibrium regions with different number of phases. These boundaries limit zones cannot be crossed by simple

distillation, and their projection over the ternary diagram of composition corresponds to the boundary lines of the distillation maps^{[18],[8]}.

Figure 3 represents the diagram of a liquid-vapour ternary system with three binary homogeneous azeotropes (two minimum and one maximum) and one saddle homogeneous ternary azeotrope. In this case we can deduce four boundary lines: the typical boundaries lines that connect the three binary azeotropes with the ternary azeotrope, and a new boundary line that connects the pure component 1 and the saddle ternary azeotrope (line TA-Component 1). A saddle azeotrope is formed at the intercept of a valley and a ridge. In the figure we can also see the residue curves at the different regions in the composition triangle.

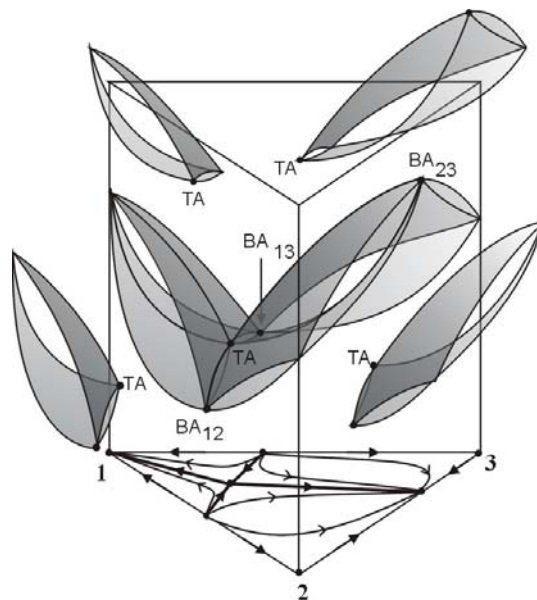

Figure 3. Temperature-composition diagram of a liquid-vapour ternary system with three binary azeotropes (two minimum, BA₁₂ and BA₁₃, and one maximum, BA₂₃) and one saddle ternary azeotrope (TA).

Figures 4 and 5 present different liquid-vapour diagrams whose boundary lines and residue lines are shown in order to illustrate the wide variety of possible behaviours.

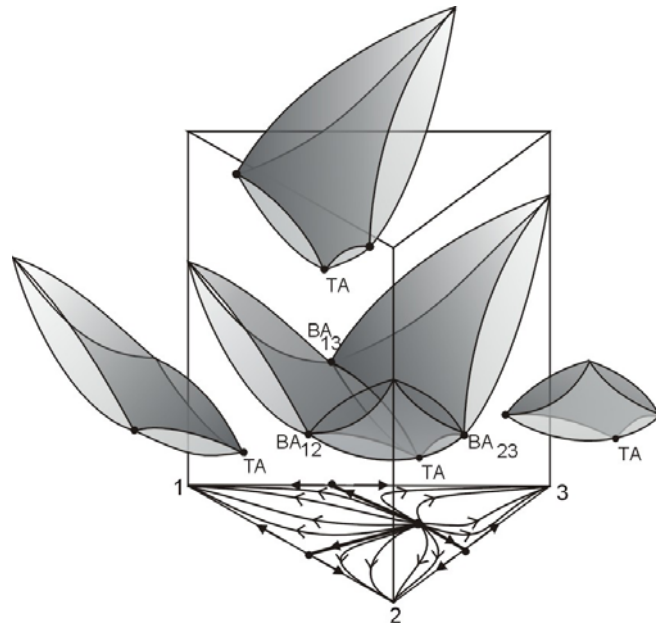

Figure 4. Temperature-composition diagram of a liquid-vapour ternary system with three minimum binary azeotropes and one ternary azeotrope (TA) of minimum temperature.

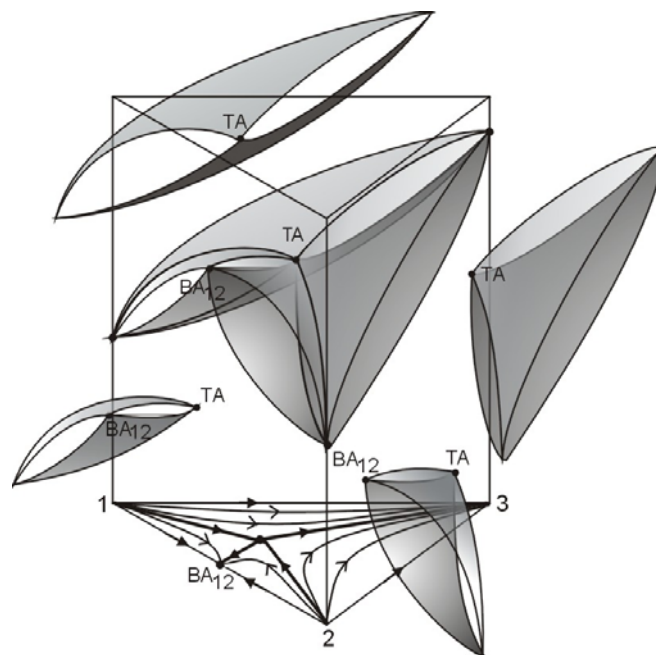

Figure 5. Temperature-composition diagram of a liquid-vapour ternary system with one maximum binary azeotrope and one saddle ternary azeotrope (TA).

Conclusions

The present paper shows some examples where special behaviours are selected to help the understanding of the shapes and the behaviour of the systems, and to clarify some aspects

concerning to the experimental determination and graphical representation of liquid-liquid-vapour equilibrium data, and also emphasise the importance of the knowledge and consideration of the expected qualitative behaviour of the system under study, obtained from the binaries and ternaries azeotropic data.

References

- [1] J.S. Marsch, 1935, Principles of Phase Diagrams (Alloys of Iron Research, Monograph Series), First Edition, McGraw-Hill Book Company, Inc., New York.
- [2] Pham H.N. and Doherty, M. F., 1990, Chem. End. Sci., 45 (7), 1823-1836.
- [3] Pham H.N. and Doherty, 1990, M. F., Chem. End. Sci., 45 (7), 1837-1843.
- [4] Pham H.N. and Doherty, M. F., 1990 Chem. End. Sci., 45(7), 1845-1854.
- [5] Safrit, B.T. and Westerbeg, A.W., 1997, Ind. Eng. Chem. Res., 36, 1827-1840.
- [6] Laroche, L., Bekiaris, N., Andersen, H.W. and Morari, M., 1997, AIChE Journal, 38 (9), 1309-1328.
- [7] Bekiaris, N., Meski, G.A. and Morari, M., 1996, Ind. Eng. Chem. Res., 35, 207-227.
- [8] Widagdo, S. and Seider, W.D., 1996, AIChE Journal, 42(1), 96-130.
- [9] Cairns, B.P. and Furzer, I.A., 1990, Ind. Eng. Chem. Res., 29, 1349-1363.
- [10] Cairns, B.P. and Furzer, I.A., 1990, Ind. Eng. Chem. Res., 29, 1364-1382.
- [11] Stichlmair, J.G. and Herguijuela J.R., 1992, AIChE Journal, 38(10), 1523-1535.
- [12] Foucher, E.R., Doherty, M.F. and Malone M.F., 1991, Ind. Eng. Chem. Res., 30(4), 760-772 and 30, 2364.
- [13] Seader, J.D. and Henley, E.J., 1998, Separation Process Principles, John Wiley & Sons, Inc., New York.
- [14] Gmehling, J.; Menke, J.; Fischer, K. and Krafczyk, J., 1994, Azeotropic Data. VCH Publishers Inc. New York.

- [15] F. Ruiz Beviá F., Marcilla Gomis, A., 1993, Fluid Phase Equilibria, 89, 387-395.
- [16] Marcilla, A., Conesa, J.A., Olaya, M.M., 1997, Fluid Phase Equilibria, 135, 169-178.
- [17] J.A. Reyes, J.A. Conesa, A. Marcilla, M.M. Olaya, 2001, Ind. Eng. Chem. Res., 40, 902-907.
- [18] Doherty, M.F. and Perkins, J.D., 1979, Chem. Eng. Sci., 34, 1401-1414.

Updated references

1. Marcilla A, Reyes-Labarta JA, Olaya MM. Should we trust all the published LLE correlation parameters in phase equilibria? Necessity of their Assessment Prior to Publication. Fluid Phase Equilib. 2017; 433: 243-252.
2. Marcilla A, Olaya MM, Serrano MD, Reyes-Labarta JA. Methods for improving models for condensed phase equilibrium calculations. Fluid Phase Equilib. 2010; 296: 15-24.
3. Marcilla A, Olaya MM, Reyes-Labarta JA. The unavoidable necessity of considering temperature dependence of the liquid Gibbs energy of mixing for certain VLE data correlations. Fluid Phase Equilib. 2018; 473: 17-31.
4. Marcilla A, Olaya MM, Reyes-Labarta JA, Carbonell-Hermida P. Procedure for the correlation of normal appearance VLE data, where the classical models dramatically fail with no apparent reason. Fluid Phase Equilib. 2019; 493: 88-101.
5. Labarta JA, Olaya MM, Marcilla A. GMcal_TieLinesLV: Graphical User Interface (GUI) for the Topological Analysis of G^M Functions for Binary and Ternary (isobaric or isothermal) Vapor-Liquid Equilibrium (VLE) data (including Tie-Lines, Derivatives, Distillation Boundaries etc.). Institutional Repository of the University of Alicante ([RUA](http://hdl.handle.net/10045/122857)). 2022; Available at: <http://hdl.handle.net/10045/122857>.
6. Marcilla A, Olaya MM, Reyes-Labarta JA. Simultaneous VLLE data correlation for ternary systems: Modification of the NRTL equation for improved calculations. Fluid Phase Equilib. 2016; 426, 47-55.
7. Marcilla A, Olaya MM, Reyes-Labarta JA. Comments on the correlation of vapor-liquid equilibrium (VLE) data in azeotropic ternary systems. Fluid Phase Equilib. 2016; 426: 110-118.
8. Marcilla A, Reyes-Labarta JA, Serrano MD, Olaya MM. GE Models and Algorithms for Condensed Phase Equilibrium Data. Regression in Ternary Systems: Limitations and Proposals. Open Thermodyn. J. 2011; 5(Suppl 1-M5): 48-62.

9. Labarta, J.A.; Serrano, M.D.; Velasco, R.; Olaya, M.M.; Marcilla, A. Approximate Calculation of Distillation Boundaries for Ternary Azeotropic Systems. *Ind. Eng. Chem. Res.* **2011**, 50 (12), 7462-7466. DOI: <http://dx.doi.org/10.1021/ie101873>.
10. Labarta, J.A.; Caballero, J.A.; Marcilla, A. Numerical Determination of Distillation Boundaries for Multicomponent Homogeneous and Heterogeneous Azeotropic Systems. *Computer Aided Chemical Engineering.* **2010**, 28(C), 643-648. DOI: [http://dx.doi.org/10.1016/S1570-7946\(10\)28108-7](http://dx.doi.org/10.1016/S1570-7946(10)28108-7).
11. Gómez, A.; Ruiz, F.; Marcilla, A.; Reyes, J.; Menargues, S. Diseño de la separación de mezclas ternarias (I). Conceptos gráficos del equilibrio entre fases. *Ingeniería Química.* 2001; 377: 219-229 (Repositorio Institucional RUA: <http://hdl.handle.net/10045/24715>).
12. Gómez, A.; Ruiz, F.; Marcilla, A.; Reyes, J.; Menargues, S. Diseño de la separación de mezclas ternarias (II). Aplicación de conceptos gráficos a la separación de mezclas azeotrópicas. *Ingeniería Química.* 2001; 379: 253-262 (Repositorio Institucional RUA: <http://hdl.handle.net/10045/24716>).

Figure Captions

Figure 1a. Temperature-composition diagram of a liquid-liquid-vapour ternary system with one heterogeneous azeotrope.

Figure 1b. Different zones and surfaces in the ternary phase diagram from Figure 1a.

Figure 2a. Temperature-composition diagram of a liquid-liquid-vapour ternary system with three binary azeotropes (two homogeneous, BA₂₃ and BA₁₃, and one heterogeneous, BA₁₂) and one homogeneous minimum ternary azeotrope (TA).

Figure 2b. Separation in different sectors in the temperature-composition diagram shown in Figure 2a.

Figure 2c. Different cuts along the three axes (isothermal and constant composition planes) in the temperature-composition diagram shown in Figure 2a (liquid-liquid-vapour ternary system with three binary azeotropes, and one minimum homogeneous ternary azeotrope).

Figure 3. Temperature-composition diagram of a liquid-vapour ternary system with three binary azeotropes (two minimum, BA₁₂ and BA₁₃, and one maximum, BA₂₃) and one saddle ternary azeotrope (TA).

Figure 4. Temperature-composition diagram of a liquid-vapour ternary system with three minimum binary azeotropes and on ternary azeotrope (TA) of minimum temperature.

Figure 5. Temperature-composition diagram of a liquid-vapour ternary system with one maximum binary azeotrope and one saddle ternary azeotrope (TA).