



Recent developments for beam intensity increase operation

T. André, P. Anger, J.L. Baelde, R. Baumgarten, C. Doutressoules, B. Ducoudret, G. Etaix, C. Jamet, C. Mariette, E. Petit, et al.

► To cite this version:

T. André, P. Anger, J.L. Baelde, R. Baumgarten, C. Doutressoules, et al.. Recent developments for beam intensity increase operation. Baron E., Lieuvain M. 15th International Conference on Cyclotrons and their Applications, Jun 1998, Caen, France. IOP Publishing, pp.290-292, 1999. <in2p3-00021786>

HAL Id: in2p3-00021786

<http://hal.in2p3.fr/in2p3-00021786>

Submitted on 27 Nov 2013

HAL is a multi-disciplinary open access archive for the deposit and dissemination of scientific research documents, whether they are published or not. The documents may come from teaching and research institutions in France or abroad, or from public or private research centers.

L'archive ouverte pluridisciplinaire **HAL**, est destinée au dépôt et à la diffusion de documents scientifiques de niveau recherche, publiés ou non, émanant des établissements d'enseignement et de recherche français ou étrangers, des laboratoires publics ou privés.

RECENT DEVELOPMENTS FOR BEAM INTENSITY INCREASE OPERATION

T. André, P. Anger, J.L. Baelde, R. Baumgarten, C. Doutressoulles, B. Ducoudret
 G. Etaix, C. Jamet, C. Mariette, E. Petit, G. Tichoux
 GANIL, BP5027, 14076 CAEN Cedex

The aim of the beam intensity increase operation (THI project) is to multiply the present intensities for lightest ions by a factor of fifteen in order to reach maximum power of six kilowatts [1].

The main objective is the production of large amounts of rare isotopes, either with SISSI (device intended for producing radioactive beams), or with SPIRAL (production and acceleration of radioactive ion beams).

As part of this THI project, new developments have been required such as spiral scanners, for beam profile measurements, and safety system to protect equipments against beam losses.

Other developments are being carried on to improve the high intensity beam operation.

1 Spiral wire beam profile monitors

1.1 Mechanical description.

The spiral wire beam profile monitor (spiral scanner) is made with a tungsten wire, with a spiral shape, rotating in the ion beam. Its rotation axis is at 45° from horizontal and vertical axis (figure 1).

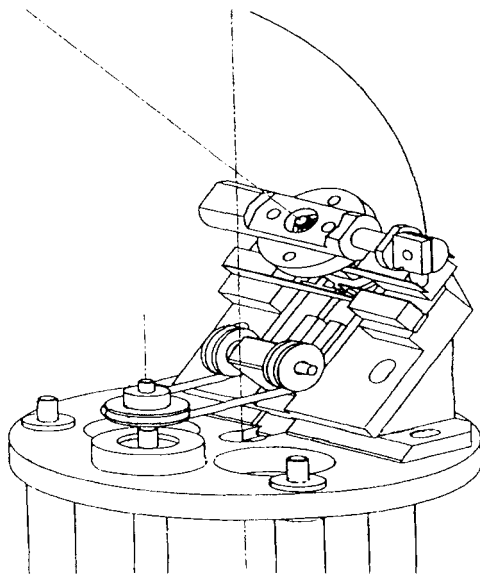

Figure 1

The diameter of the wire is one millimeter. During each turn, the wire realizes an horizontal and a vertical scanning of the beam. Rotation is assured by a synchronous motor and the speed is one turn per second. Transmission of movement from the motor (outside the pipeline) to the spiral scanner (inside the pipeline) is made by a magnetic coupling, which means that no air to vacuum feedthrough is needed. Coding of the wire position is realized with a disk, constituted of slits, and optical fibers to transmit and receive light.

2.1 Beam profile acquisition.

The spiral wire beam profile monitors are used with a beam intensity between 100 nAe and 100 μAe, which means up to 100 watts beam power.

We use a logarithmic current to voltage converter in order to get a great beam intensity dynamic without range changing.

Acquisition of beam profile is made by a VME board, developed at GANIL (figure 2). After treatment, datas are stocked in a double access memory and an interrupt is sent to VME CPU which reads beam profile datas and visualizes them on a workstation (figure 3).

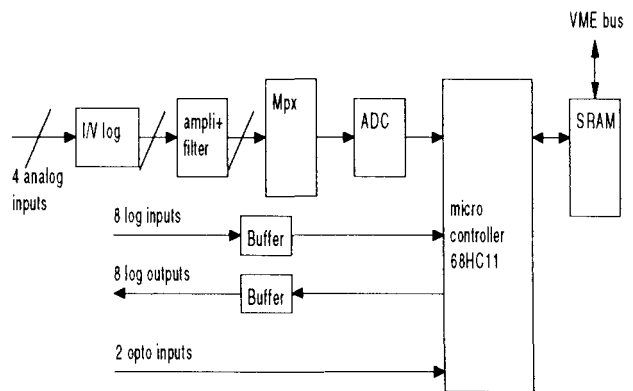

figure 2

L1.DIA.FST42.VE

L1.DIA.FST42.HO

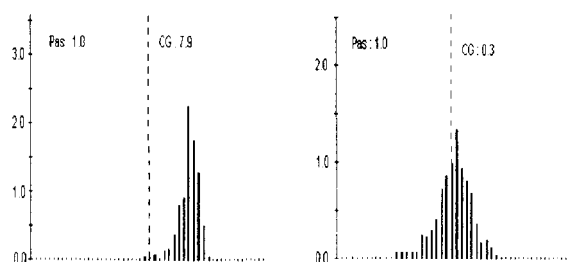

figure 3

2 Beam losses detection .

2.1. Beam losses detectors [2].

Inside the cyclotrons we use existing electrodes installed at the input of the injection and extraction equipments. These electrodes are used for beam losses detection but also for injection and extraction beam tuning. We have 11 of these electrodes for cyclotron CSS1 and 26 for cyclotron CSS2.

Along beam lines we have installed insulated diaphragms at the input and output of dipoles. 18 of them are located in beam line between cyclotrons CSS1 and CSS2, and 10 in beam line after cyclotron CSS2.

Current transformers are used for the beam intensity transmission measurements through beam lines and through cyclotrons. This allows us to detect a fast change in beam transmission along accelerators.

2.2. Detection electronics.

These sensors are connected to logarithmic current to voltage converters and acquired by a VME board, in order to minimize losses during the tuning of the beam [3] and also to ensure a safety action during the high intensity beam production.

Each sensor has its own beam losses threshold memorized in an EPROM on the VME board.

Any sudden loss of intensity is detected by these beam losses sensors and by the beam intensity transmission system, with a reaction time of 10 ms.

When a safety action occurs, an alarm message is sent to the control room to indicate which sensors have triggered.

3 Safety system against beam losses.

Beam losses detectors are connected to a safety system which is composed of fast hardware electronics, an API and a chopper (figure 4).

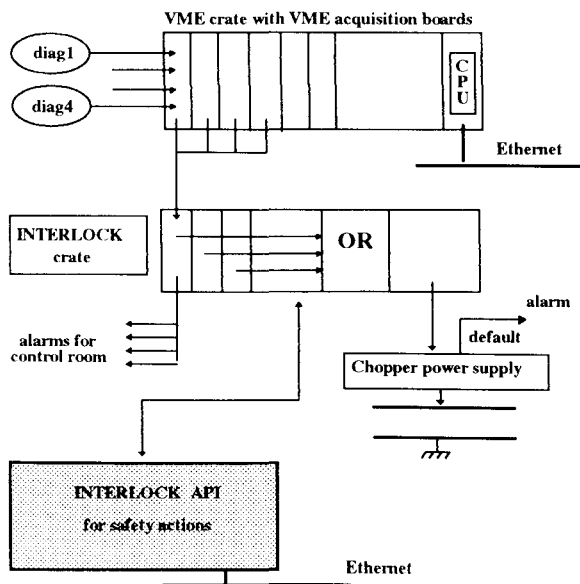

In high intensity beam configuration, beam losses detectors are activated in order to protect equipments against fast beam losses. If needed, the safety system cuts the beam by activating the chopper and orders the insertion of pepperpots. When pepperpots insure a beam power reduction under the critical level, the safety system stops the beam cut by the chopper. In that situation the problem can be analyzed and corrected.

An application program, for the safety system, is available on workstations in the main control room to help in high intensity beam tuning.

The main functions of this application program are :

- The choice of the operation stage (high intensity beam tuning or beam surveillance or beam production). Depending on the operation stage, beam losses detectors are or are not activated in the safety system.
- The display of the beam intensity (and power) at different locations of the accelerator, and the display of beam intensity transmission through beam lines and cyclotrons.
- The visualization of beam losses detectors which trigger off safety action, in order to analyse the reasons of the trigger action and to improve the beam tuning.
- The possibility to activate what we call automatic resetting. This means that if beam losses trigger off a safety action, we reset the memorized beam losses and we send the high intensity beam through accelerators again. This allows us to maintain the high intensity even when electrostatic discharges occur. If the frequency of beam losses triggers is too high, we automatically come back to reduced beam power.

4 On going developments.

4.1. Non interceptive beam intensity measurements.

Currently, beam intensity diagnostics are current transformers AC low frequency with a resolution less than 4nAe. This type of beam instrumentation has the following disadvantages :

- to have a chopped beam (9% of beam cut).
- to be sensitive to low frequency noises (microphonic noise, 50 Hz, ...).

So we decided to study a beam intensity measurement device working on the high frequency structure of the beam (bunch width ~5ns, frequency of 7 to 14 MHz according to the type of ion beam).

We detect the magnetic field with a FCT (Fast Current Transformer manufactured by Bergoz), or the electrical field with a phase probe. To obtain a good signal noise ratio, the signal of these two types of pick up is then treated by a synchronous detection (see figure 5). Then, with a low pass filter we get a voltage proportionnal to the beam intensity.

We can note that 2 low pass filters are available :

- cut off frequency of 3 Hz for beam intensity accessible by control room.
- cut off frequency of 30 Hz for beam losses detection (beam transmission).

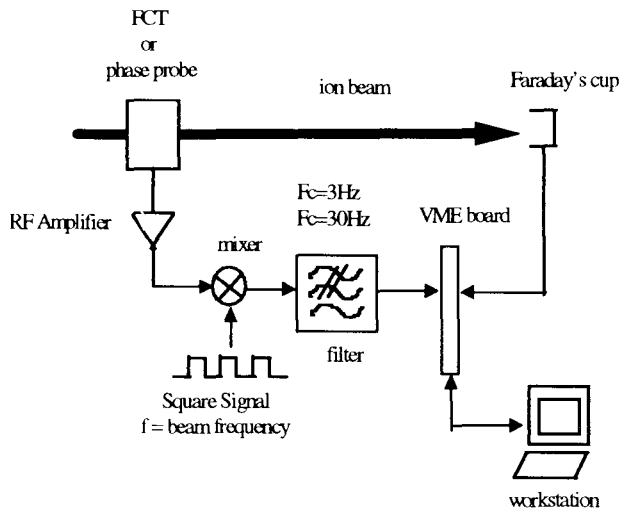

Figure 5

The area of the signal coming from the FCT depends on the average value of the intensity while the area of the signal coming from the phase probe depends not only on the average value of the intensity but also of the speed of ions. Consequently, the probe needs a calibration with a Faraday's Cup for each type of beam.

Results :

FCT

absolute accuracy in theory
resolution : $<4nAe$

Phase probe

accuracy fixed by the accuracy of the Faraday's cup
resolution : $<1nAe$

4.2. Feedback loops.

Feedback loops, in operation at present time (figure 6), are complete analogical loops. They are based on the beam phase measurements and are five in number [4].

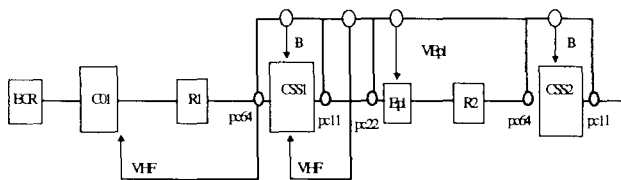

Figure 6

The aim of new feedback loops is to improve the beam stability, and more particularly for the high intensity beam transport.

The two main ideas for that are :

- to increase the number of feedback loops. We think of realizing 10 feedback loops.
- to achieve feedback loops using numerical technics to modify loop parameters more easily according to type of ion beam (better adaptability).

The following figure shows what we intend to develop in the future (figure 7).

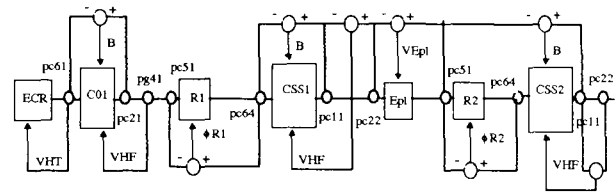

Figure 7

We think of realizing an architecture, based on commercial VME boards, which functions would be :

- the acquisition of signals coming from the beam phase and beam position systems.
- the calculation of corrections to apply to the equipments (magnetic fields and RF voltages of the 3 cyclotrons, RF phases of the 2 rebunchers and the extraction high voltage of the ECR ion source).
- the applying of these corrections.

These numerical feedback loops would be supervised by a workstation, from main control room, through Ethernet connected to VME crate.

5 Conclusions.

High intensity beam tuning have been done for tests (and not for production), so we can point out some conclusions. Concerning beam losses detection and safety system, results are very good and now we are ready to produce high intensity beams in safe conditions.

About the spiral wire beam profile monitor, results are encouraging but we meet some problems with beam intensity instabilities. So some improvements are needed.

For non interceptive beam intensity measurements, very good results are obtained in tests with ion beam. Now we have to industrialize the signal treatment and the connection to the control system.

Concerning new feedback loops, a lot of work is needed to study each of them and to definitely install them.

6 References.

- [1] « Upgrading the Ganil facilities for high intensity heavy ion beams », E. Baron and the Ganil staff. Proceedings of the 14th International Conference on Cyclotrons. Cap Town (1995).
- [2] « Détection des pertes faisceau et système de protection », R. Baumgarten, C. Jamet, E. Petit. Internal report Ganil/602.94/EP.
- [3] « Measuring beam losses in the THI project ». L. David, P. Duneau, E. Lécorché, P. Lermine, E. Lemaître, M. Ulrich. Report GANIL A 97 03.
- [4] « Beam diagnostics at Ganil ». F. Loyer. Report GANIL A 86.01.