



THI safety system

C. Jamet, T. André, P. Anger, J.L. Baelde, C. Doutressoulles, B. Ducoudret,
E. Petit, E. Swartvagher

► **To cite this version:**

C. Jamet, T. André, P. Anger, J.L. Baelde, C. Doutressoulles, et al.. THI safety system. 7th European workshop on beam diagnostics and instrumentation for particle accelerators, Sep 2005, Lyon, France. Joint Accelerator Conferences Website, pp.169-171, 2005. <in2p3-00169968>

HAL Id: in2p3-00169968

<http://hal.in2p3.fr/in2p3-00169968>

Submitted on 5 Sep 2007

HAL is a multi-disciplinary open access archive for the deposit and dissemination of scientific research documents, whether they are published or not. The documents may come from teaching and research institutions in France or abroad, or from public or private research centers.

L'archive ouverte pluridisciplinaire **HAL**, est destinée au dépôt et à la diffusion de documents scientifiques de niveau recherche, publiés ou non, émanant des établissements d'enseignement et de recherche français ou étrangers, des laboratoires publics ou privés.

THI SAFETY SYSTEM

Christophe Jamet, Thierry André, Pascal Anger, J.L. Baelde,
Clément Doutressoulles, Bernard Ducoudret, E. Petit, Eric Swartvagher
GANIL, BP 55027, 14076 Caen Cedex 5, France

Abstract

For several years, GANIL has been allowed to reach a maximum beam power of six kilowatts (400W in normal mode) thanks to the THI system (High Intensity Transport System). Three modes of running are necessary to accelerate a THI beam ("Injector" mode, "tuning" mode and "surveillance" mode). The "surveillance" mode requires a safety system to protect equipment against beam losses. Inside cyclotrons, diagnostics measure beam-loss currents at the injection and extraction devices. Along beam lines, diaphragms measure beam-loss currents at the input and output of dipoles. Current transformers are used for beam transmission measurements through beam lines and the cyclotrons. The safety system controls beam losses and quickly cuts the beam with a chopper if losses exceed thresholds. These thresholds can be seen and changed by software.

INTRODUCTION

The production of exotic ions at GANIL is performed by fragmentation of the projectile in the target of SISSI [5] or/and by the ISOL method with an acceleration of the exotic beams by the cyclotron CIME [3].

Layout of GANIL

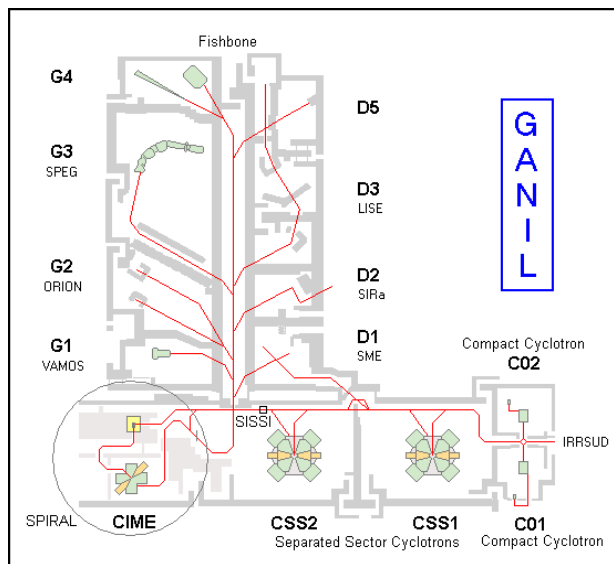

Both devices require high intensity primary beams. Primary beam intensity has been increased up to $15\mu\text{Ae}$ (3kW) for ^{13}C at 95MeV/A and $26\mu\text{Ae}$ (5kW) for ^{36}Ar at 95MeV/A. Therefore, uncooled or unshielded elements can melt very rapidly and must be protect by a safety system.

THI MODES

Three modes of running are necessary to tune a THI beam. C01 or C02 can be chosen to post accelerate the THI beam.

“Injector mode”

This mode permits us to accelerate the beam at the input of SSC1. ($P_{\text{beam}} < 400\text{W}$)

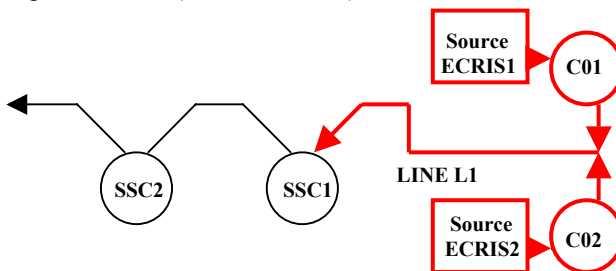

“Tuning mode”

This mode permits us to tune the beam through the accelerators. Beam chopping rates limit the beam power ($P_{\text{beam}} < 400\text{W}$)

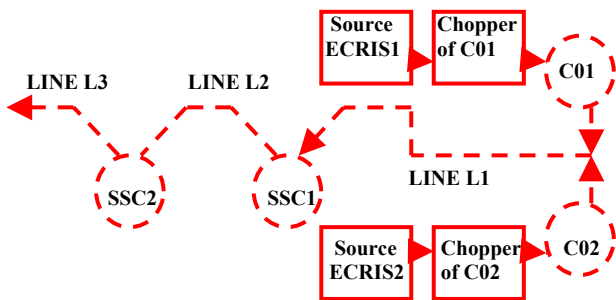

“Surveillance mode”

This mode permits us to tune the beam at a maximum power ($P_{\text{beam max}} = 6\text{kW}$). Beam current average is increased progressively by changing beam-chopping rates. The safety system controls beam losses.

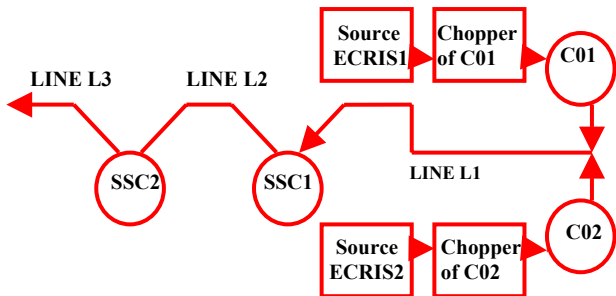

BEAM LOSSES DIAGNOSTICS

Inside cyclotrons, diagnostics measure beam-loss currents at the input of the injection and extraction. Along beam lines, diaphragms detect beam-loss currents at the input and output of dipoles.

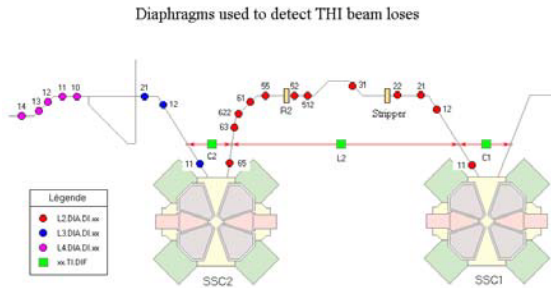

Current transformers (GANIL ACCT) are used to measure the beam transmission through beam lines and the cyclotrons. A change of the efficiency within the accelerators can be detected. The beam is modulated to measure beam currents with the ACCT. The maximum chopping rate is 91%.

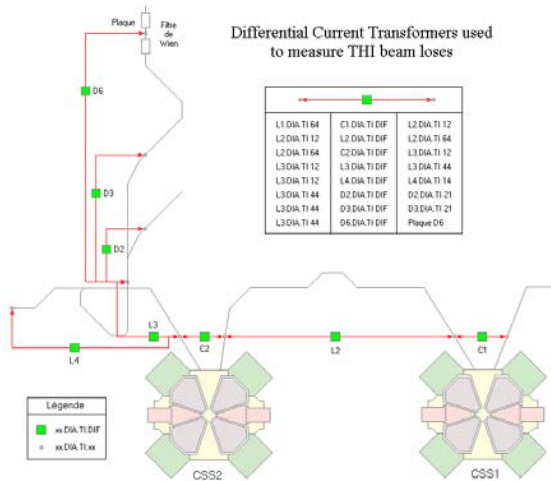

SAFETY SYSTEM

Interceptive beam diagnostics are connected to test boards. Each board is able to inject a test signal (10µA) to the diagnostics and filter the signal from the device. Test signals can be sent by software. Each VME board (PFAIS) measures 4 diagnostic currents with logarithmic I/V converters, which generate a voltage proportional to the logarithm of the current. This voltage is digitised, compared to a threshold and numerically converted into a current.

The signals generated by the current transformers (ACCT) are sent to a differential board. An inhibition board validates the difference between 2 current transformers. Then a VME board digitises, compares to a threshold and numerically converts into a current.

26/05/2005

General Layout of THI Safety System

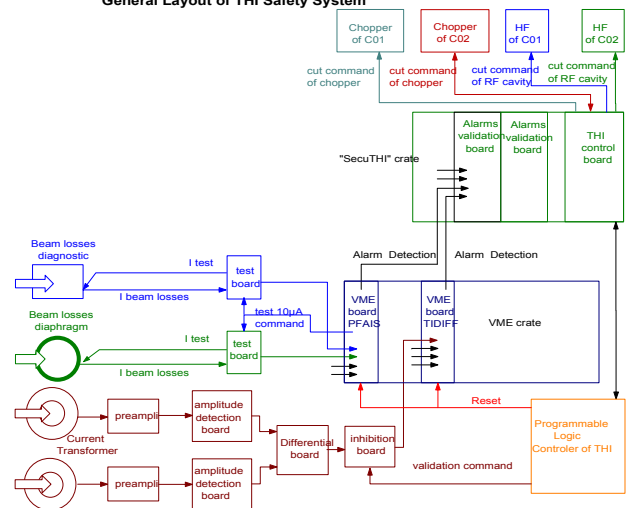

“Alarm detection” signals are generated by VME boards and sent to “alarm validation” boards. “THI control” board collects all alarm signals. A programmable logic controller indicates to the control board different configuration states. If “surveillance” mode is validated for example, when a VME board generates an alarm detection, the THI control board commands the chopper to cut the beam. If a problem is detected on the chopper, the acceleration voltage of the C0 injector is cut.

A reloading system gives us the possibility to restore the beam just after an overshoot. When 3 trigger actions arrive in under 10 seconds, the programmable logic controller passes from “surveillance “ mode to “tuning” mode.

CONTROL

Software is used to control and tune the beam.

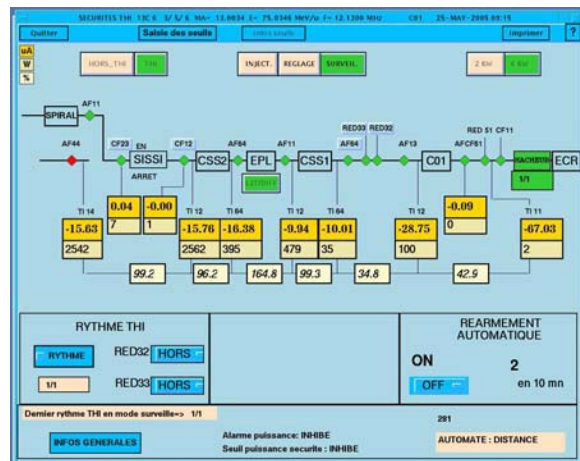

Users can choose various modes of running (normal mode or THI mode and injector, tuning, surveillance mode). Beam current (µA), beam power (W) and efficiency (%) are displayed on the screen. Beam chopping rates can be changed (rythme) and pepper pots inserted in the lines (red32 and red33).

A second program enables us to control and change thresholds of each diagnostic device.

PHOTOS OF DIAGNOSTICS

SEUILS THI 48Ca20 8/17/18 HA- 47.9525 E- 29.0447 MeV/u I- 7.8220 MHz C01 18-DEC-2003 15:41										
Quitter	Init	Seuils	Seuils en intensite	Fonction sur seuils		Infos seuils	Test deplacement			Imprimer ?
Diagnostic	Seuil	Diagnostic	Seuil	Diagnostic	Seuil	Diagnostic	Seuil	Diagnostic	Seuil	
C1.DIA.EI.PHO	5.7 W	L3.DIA.D11.J	5.7 W	C2.DIA.EI.ID	5.0 W	L3.DIA.D11.J	23.8 W	L4.DIA.D10.J	23.8 W	
C1.DIA.EI.IVE	5.7 W	L3.DIA.D12.J	5.7 W	C2.DIA.EI.JG	5.0 W	L3.DIA.D12.J	23.8 W	L4.DIA.D11.J	23.8 W	
C1.DIA.M2.PHO	5.7 W	L3.DIA.D01.J	6.8 W	C2.DIA.EI.IB	5.0 W	L3.DIA.D01.J	23.8 W	L4.DIA.D12.J	23.8 W	
C1.DIA.M2.IVE	5.7 W	L3.DIA.D02.J	56.8 W	C2.DIA.EI.H	5.0 W	L3.DIA.TD1.F.J	46.4 W	L4.DIA.D13.J	23.8 W	
C1.DIA.M3.J	5.7 W	L3.DIA.D01.J	5.0 W	C2.DIA.M2.ID	5.0 W	L3.DIA.TD1.J	47.6 W	L4.DIA.D14.J	23.8 W	
C1.DIA.M3.I	5.7 W	L3.DIA.D02.J	15.0 W	C2.DIA.M2.JG	5.0 W	L3.DIA.D01.J	23.8 W	L4.DIA.TD1.F.J	96.7 W	
C1.DIA.EE.J	28.4 W	L3.DIA.D12.J	5.0 W	C2.DIA.M2.IB	5.0 W	L3.DIA.DH1.J	23.8 W			
C1.DIA.ME2.J	5.7 W	L3.DIA.D05.J	5.0 W	C2.DIA.M2.H	5.0 W	L3.DIA.DH4.J	23.8 W			
C1.DIA.ME3.J	5.7 W	L3.DIA.D06.J	5.0 W	C2.DIA.M2.P	5.0 W			AR.DIA.D01.J	23.8 W	
C1.DIA.ME3.PHO	5.7 W	L3.DIA.D022.J	5.0 W	C2.DIA.M3.ID	5.0 W			D2.DIA.TD1.F.J	47.6 W	
C1.DIA.ME3.IVE	5.7 W	L3.DIA.D03.J	5.0 W	C2.DIA.M3.JG	5.0 W			D3.DIA.D11.J	23.8 W	
C1.DIA.TD1.F.J	56.8 W	L3.DIA.D05.J	5.0 W	C2.DIA.M3.IB	5.0 W			D3.DIA.D12.J	23.8 W	
		L3.DIA.TD1.F.J	96.1 W	C2.DIA.M3.IB	5.0 W			D3.DIA.D01.J	23.8 W	
				C2.DIA.M3.P	5.0 W			D3.DIA.TD1.F.J	47.6 W	
				C2.DIA.M3.IPB	5.0 W			D6.DIA.TD1.F.J	47.6 W	
				C2.DIA.M3.ID	5.0 W					
				C2.DIA.M3.JG	5.0 W					
				C2.DIA.M3.IB	5.0 W					
				C2.DIA.M3.H	5.0 W					
				C2.DIA.M3.P	5.0 W					
				C2.DIA.M3.IPB	5.0 W					
				C2.DIA.EE.IPLA	95.2 W					
				C2.DIA.EE.IPLA	118.9 W					
				C2.DIA.EE.IVE	23.8 W					
				C2.DIA.ME2.J	47.6 W					
				C2.DIA.ME3.J	23.8 W					
				C2.DIA.ME3.PHO	23.8 W					
				C2.DIA.ME3.IVE	23.8 W					
				C2.DIA.TD1.F.J	135.4 W					



Beam-loss diagnostic inside cyclotron



Beam-loss diaphragm

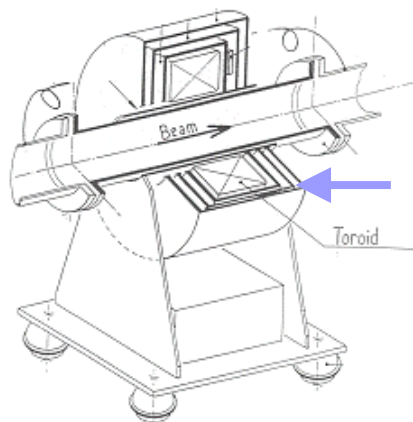

Current Transformer

Current or power thresholds can be selected. When a new beam is tuned, we initialise all thresholds in power with beam characteristics. Each value can be displayed and modified. A test command permits sending a test current to each beam-loss diagnostic device and to verify the detection.

RESPONSE TIME

To measure the response time, the beam is tuned to lose 4µAe in SSC1. We cut the beam by the chopper and we set the threshold to 2µAe. The beam is then sent through the cyclotron, and the safety system detects the loss and stops the beam.

CONCLUSIONS

The THI Safety System was started in 1995, validated in 1998 and completed in 2001, to give the possibility to send a THI beam into the experimental rooms. The system correctly protects equipment against the beam power loss.

REFERENCES

- [1] B. Jacquot et al., GANIL status report, 17th Int. Conf. On Cyclotrons and their Applications. Tokyo, 2004
- [2] F. Chautard et al., GANIL status report, EPAC 2004, Switzerland
- [3] E. Baron et al., High intensity heavy ion beams for exotic nuclei production at GANIL, 16th Int. Conf. On Cyclotrons and their Applications. Michigan 2001
- [4] M. Lieuvain et al., Commissioning of SPIRAL, the GANIL radioactive beam facility, ibid
- [5] E. Baron et al., Experience with high intensity operation of the GANIL Facility, 15th Int. Conf. On Cyclotrons and their Applications, 1998
- [6] A. Savalle et al, The SISSI facility at GANIL, EPAC 96, Sitges, Spain, June 1996.
- [7] E. Baron et al., Upgrading the GANIL Facilities for high-intensity heavy ion beams, 14th Int. Conf. On Cyclotrons and their Applications, 1995

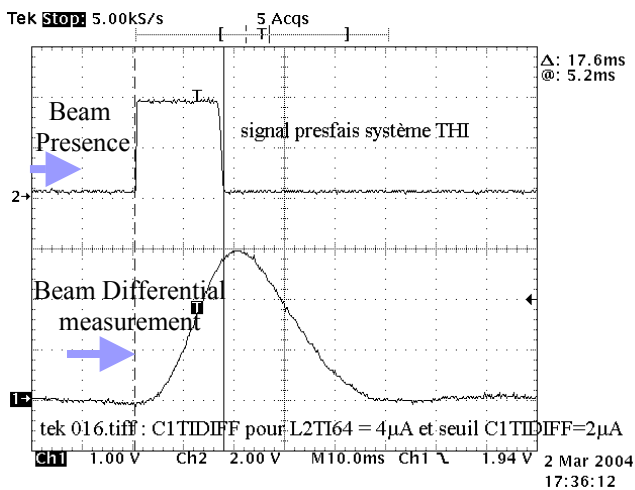

The response time for a beam current of 4µA and a threshold of 2µA is around 18 ms. It depends of the ratio between threshold and loss current.