



Status report on GANIL-SPIRAL1

F. Chautard, C. Berthe, A. Colombe, L. David, P. Dolegieviez, B. Jacquot, C. Jamet, M. Lechartier, P. Lehérissier, G. Sénécal

► **To cite this version:**

F. Chautard, C. Berthe, A. Colombe, L. David, P. Dolegieviez, et al.. Status report on GANIL-SPIRAL1. D. Rifuggiato. 18th International Conference on Cyclotrons and their Applications - Cyclotrons 2007, Oct 2007, Giardini-Naxos, Italy. pp.99-104, 2007. <in2p3-00340151>

HAL Id: in2p3-00340151

<http://hal.in2p3.fr/in2p3-00340151>

Submitted on 20 Nov 2008

HAL is a multi-disciplinary open access archive for the deposit and dissemination of scientific research documents, whether they are published or not. The documents may come from teaching and research institutions in France or abroad, or from public or private research centers.

L'archive ouverte pluridisciplinaire **HAL**, est destinée au dépôt et à la diffusion de documents scientifiques de niveau recherche, publiés ou non, émanant des établissements d'enseignement et de recherche français ou étrangers, des laboratoires publics ou privés.

STATUS REPORT ON GANIL-SPIRAL1

F. Chautard, C. Berthe, A. Colombe, L. David, P. Dolégieviez, B. Jacquot, C. Jamet, M. Lechartier, P. Lehérisier, G. Sénécal, GANIL, Caen, France.

Abstract

The GANIL facility (Caen, France) (Figure 1) is dedicated to the acceleration of heavy ion beams for nuclear physics, atomic physics, radiobiology and material irradiation. The production of radioactive ion beams for nuclear physics studies represents the main part of the activity. Two complementary methods are used: the Isotope Separation On-Line (ISOL, the SPIRAL1 facility) and the In-Flight Separation techniques (IFS). SPIRAL1, the ISOL facility, is running since 2001, producing and post-accelerating radioactive ion beams. The energy range available goes from 1.2 MeV/A to 25 MeV/A with a compact cyclotron (CIME, K=265). The running mode of this machine will be recalled as well as a review of the operation from 2001 to 2006. A point will be done on the past, present and future projects which allow to continue to develop the capacities of this equipment and to answer the new demands from the physicists, such as new beamlines for low or high energy experiments, new diagnostics of control or the adaptation of an identification system using Silicon, Germanium or plastic detectors in the requirements of the operation environment.

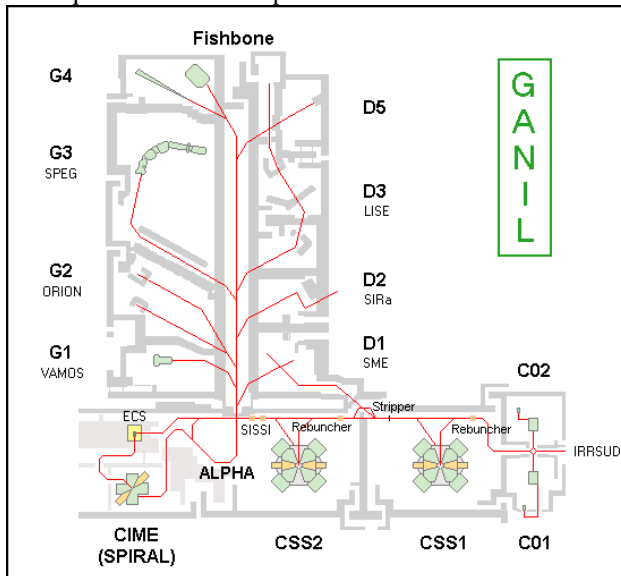

Figure 1 : GANIL layout

A MULTI-BEAM FACILITY

The facility delivers a wide spectrum of high intensity ion beams ranging from ^{12}C to ^{238}U accelerated up to 95 MeV/A. The acceleration scheme lies on the use of three cyclotrons in line, one compact (C01 or C02, K=30) and two separated sector cyclotrons (CSS1 and CSS2, K=380). More than 10 beams are available at a power

exceeding 1 kW (Table 1) (over 50 stable beams available from the GANIL sources [1]). The beam losses detectors, beam transformers and control system allow the transport of intense stable beams with power exceeding 3 kW in routine operation.

Table 1: Some of the GANIL high intensity beams, the main limitation come now from the target ability to withstand the high power density.

Beam	Imax [μAe]	10^{13} [pps]	Emax [MeV/A]	Pmax [W]	Used with Spiral
$^{12}\text{C}^{6+}$	18	1.9	95	3 200	
$^{13}\text{C}^{6+}$	18	2.	80	3 000	X
$^{14}\text{N}^{7+}$	15	1.4	95	3 000	
$^{16}\text{O}^{8+}$	16	1	95	3 000	X
$^{18}\text{O}^{8+}$	17	1	76	3 000	X
$^{20}\text{Ne}^{10+}$	17	1	95	3 000	X
$^{22}\text{Ne}^{10+}$	17	1	79	3 000	
$^{36}\text{S}^{16+}$	6.4	0.25	77.5	1100	X
$^{36}\text{Ar}^{18+}$	16	0.55	95	3 000	
$^{40}\text{Ar}^{18+}$	17	0.6	77	3 000	
$^{48}\text{Ca}^{19+}$	4-5	0.13	60	600-700	X
$^{58}\text{Ni}^{26+}$	5	0.12	77	860	
$^{76}\text{Ge}^{30+}$	5	0.12	60	760	
$^{78}\text{Kr}^{34+}$	7.5	0.14	70	1200	X
$^{124}\text{Xe}^{46+}$	2	0.03	53	300	

Beam schedule

Using its 5 cyclotrons GANIL-SPIRAL is increasingly a multi-beam facility. Up to four experiments can be run simultaneously in different rooms with stable beams:

1. Using the beam of C01 or C02, an irradiation beam line IRRSUD works with 1 MeV/A.
2. Using one charge state of the ion distribution downstream CSS1 after the ion-stripping a line uses ion in the range 4-13 MeV/A beams, for atomic physics, biology, solid states physics
3. A high energy experiments
4. An auxiliary experiments sharing the CSS2 beam
5. Additionally, stable beams can be delivered by the cyclotron CIME (SPIRAL post-accelerator) for detector tests for example.

During radioactive beam production, no more than 3 experiments are working simultaneously.

Thus, the planning schedule becomes complicated because of the number of simultaneous experiments (Table 2). 2 or 3 months before the beginning of the run, the planning should be approved by the GANIL direction, in order to prepare Spiral Target-source ensemble, beam tuning ...

Table 2: Schedule example in a multi-beam machine mode.

Date	hour	C01	C02	CSS1, CSS2	CIME	SME	SISSI	Auxiliary beam		
Saturday 28-Apr	8:00-18:00	ON LINE 48Ca	IRR SUD 200Pb 0.66 MeV/A	BEAM ON SPIRAL TARGET	E393S (Gorgen) 1UT	P655 murasaka 16UT	SISSI			
19:00-23:00	4417 2.6 MeV/A HS R46									
Sunday 30-Apr	8:00-18:00				E393S (Gorgen) C2 6 UT					
19:00-23:00	E393S (Gorgen) C2 6 UT									
Monday 1-May	8:00-18:00				P717-M-S Jurazsek				BUFFER	P655 murasaka 16UT
19:00-23:00	S26 F. Studer				Tuning alpha					
Tuesday 2-May	8:00-18:00				ON LINE 48Ca				SIRA (M.G. St Laurent) D2 6UT	40Ar ⁸⁺ 3.82 MeV/A HS R46
19:00-23:00	Tuning ECRAM 12C	Machine Study 9 E. Guerroult								
Wednesday 3-May	8:00-18:00	Tuning C02 12C	12C 206 207 208							
19:00-23:00										
Thursday 4-May	8:00-18:00									
19:00-23:00										
Friday 5-May	8:00-18:00									
19:00-23:00										

Buffers are inserted in the schedule to try to anticipate technical failure of the machine. The amount of buffer is adapted to the experiment duration. At the end of the run, indicators are extracted (Figure 2) and scheduled and effective beam time delivered to the physics experiments are compared. The buffers are usually totally used to compensate the technical interventions

Figure 2 : Shift between scheduled and effective beam time

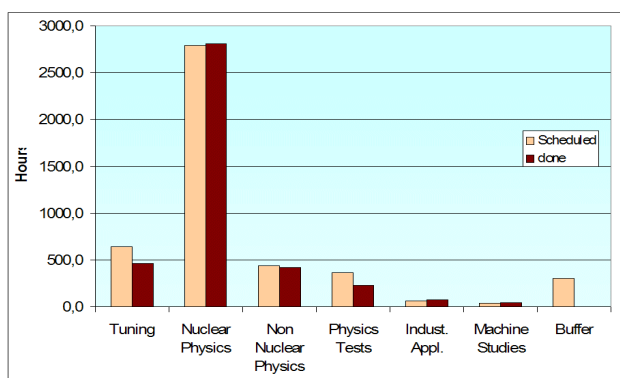

OPERATION STATISTICS

Exploitation of the machine is distributed over 4 periods of operation of approximately 8.5 weeks, separated by 4 periods for maintenance (16 weeks on the whole). Thus, since 2001, approximately 65% of the operation time was available for the physics experiments (Figure 3).

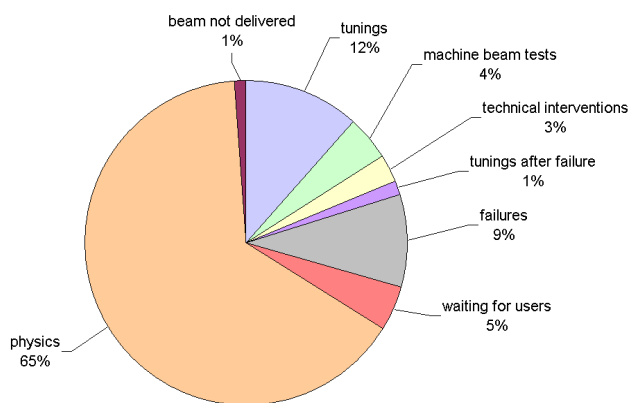

Figure 3 : Time distribution during operation from 2001 to 2006.

In Figure 4, the beam time repartition between GANIL and SPIRAL is shown from 2002. With an average of 3700 h of beam to the physics, the part of SPIRAL increased since 2002. In 2006, because of the unavailability of SISSI in 2005, a great number of experiments using this equipment were scheduled instead of SPIRAL experiments

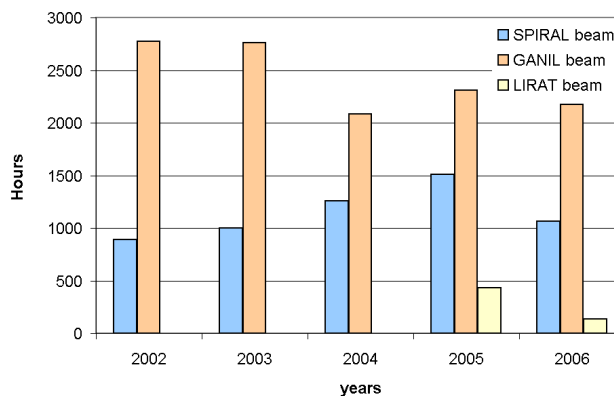

Figure 4: Beam time distribution between GANIL and SPIRAL.

SPIRAL: the ISOL Facility

For the production and acceleration of radioactive ion with the ISOL method, the stable heavy ion beams of GANIL are sent onto a target and source assembly. The radioactive atoms produced by nuclear reactions are released from the target, kept at high temperature, into an ECR source. After ionisation and extraction from the source (extraction voltage < 34 kV), the multi-charged radioactive ions are accelerated up to a maximum energy of 25 MeV/A by the compact cyclotron CIME (K=265). The first SPIRAL beam delivered to the physics was ¹⁸Ne in October 2001. Since, more than 30 radioactive beams were produced in 5000 hours of SPIRAL operation over 12000 h of total operation of the GANIL. SPIRAL also provides 700 hours of stable beams to preset the experiments or for the development of detectors. A list of the radioactive beams [2] delivered is reported in Table 3.

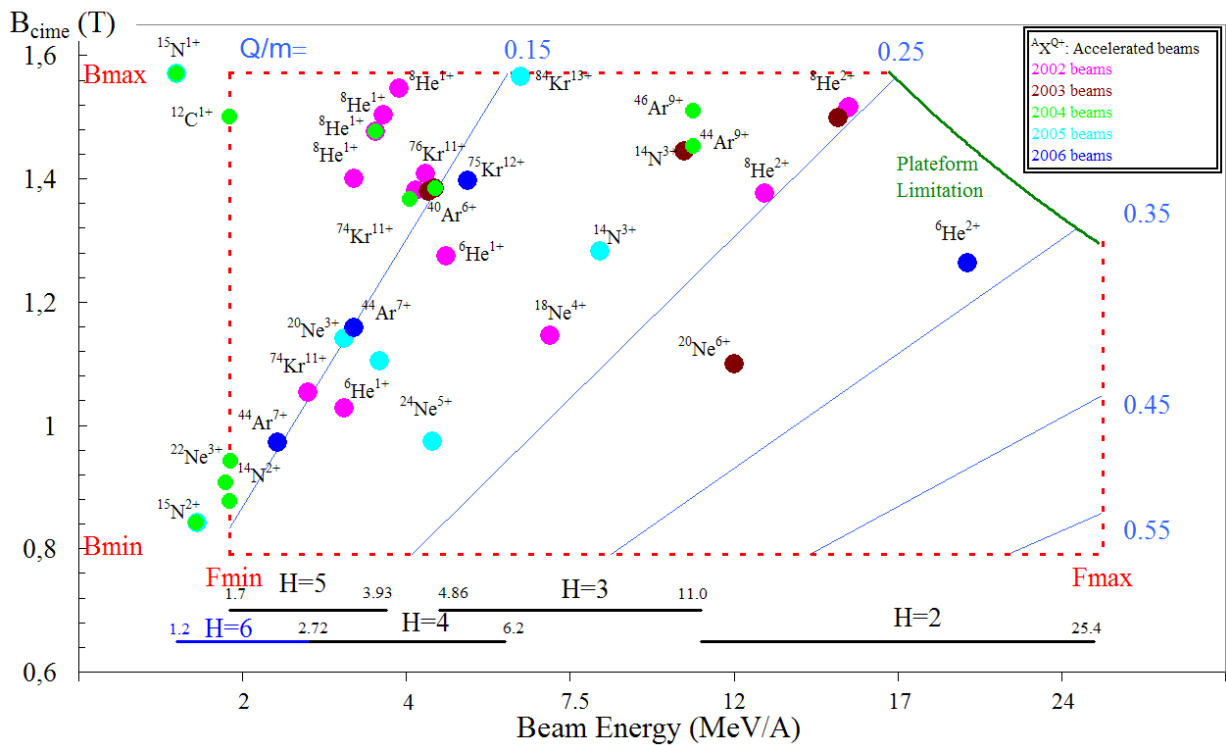

Figure 5: Working diagram of SPIRAL with accelerated beams since 2002

ion	W [MeV/A]	[pps]	ion	W [MeV/A]	[pps]
¹⁸ Ne	7	106	³¹ Ar	1.45	1.5
⁸ He	15.5	104	⁶ He	5	3.10 ⁺⁷
⁸ He	3.5	105	⁸ He	15.4	2.10 ⁺⁴
²⁴ Ne	4.7	2 105	⁸ He	3.9	8.10 ⁺⁴
⁷⁴ Kr	4.6	1.5 104	⁸ He	3.5	6.10 ⁺⁵
⁸ He	15.4	1.5 104	¹⁸ Ne	7	10 ⁺⁶
⁸ He	15.4	9 103	²⁴ Ne	10	2.10 ⁺⁵
²⁴ Ne	10	2 105	²⁶ Ne	10	3.10 ⁺³
⁸ He	15.4	2.5 104	⁴⁴ Ar	10.8	2.10 ⁺⁵
¹⁵ O	1.2	1.7 107	⁴⁶ Ar	10.3	2.10 ⁺⁴
²⁴ Ne	7.9	1.4 105	⁷⁴ Kr	2.6	1.5.10 ⁺⁴
³³ Ar	6.5	3 103	⁷⁶ Kr	4.4	6.10 ⁺⁵
⁶ He	3.8	2.8 107	⁷⁵ Kr	5.5	2 105
⁸ He	15.4	2.5 104	⁴⁴ Ar	3.8	3 105
³⁵ Ar	0.43	4 107	⁶ He ²⁺	20	5 106
⁶ He	2.5	3.7 107	⁶ He ¹⁺	Lirat	2 108

Table 3: Radioactive beam produced and post-accelerated from 2001 to 2006.

Additionally, progress in the tuning time was observed, Figure 6, being of about 20% in the first years to be reduced to 7% today. This is mainly due to a better knowledge of the machine behaviour but also by the building of a parameter database where initial theoretical figures are replaced by experimental figures. The tuning feedback informations from operators are also valuable and taken into account in the next tuning.

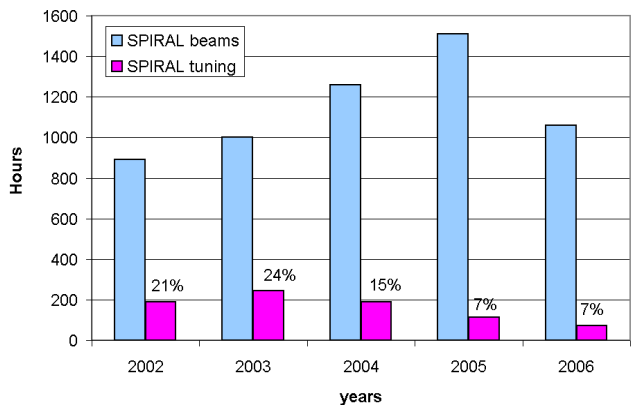

Figure 6: Distribution of the tuning time compared to the available SPIRAL beam time

AGEING PROBLEM and MAINTENANCE

R2 Rebuncher

A rebuncher installed before CSS2 was unavailable since 2002 because of defective RF contactors. The cavity is repaired and is back in line since the beginning of 2007. The clear interest of such a rebuncher is to reduce the beam losses in CSS2 deflector which result in the improvement of beam stability, (especially heavy ions such as krypton). A second advantage is the reduction of the bunch time width ΔT with CSS1 beam:

- Without R2 $\Delta T_{FWHM} = 2.0 - 1.5$ ns
- With R2 $\Delta T_{FWHM} \sim 1.0$ ns

One RF cavity acceleration in SSC

Since few years, the accelerating cavities of the SSC encountered water leaks due to 25 years of functioning. Interventions on such water circuits require to remove the whole cavity to access and repair. Inducing one week delay to physics experiment.

Acceleration in a Separated Sector Cyclotron with only one cavity is possible. However the shut down of one of the two RF cavities double the turn number, dividing the turn separation. Moreover a strong H=1 oscillation appears. The defect is much stronger in CSS1 than in CSS2. Analytical calculations and beam dynamics simulations showed that the defect can be partially compensated by a magnetic field law modification of the sectors.

$$\frac{\Delta B_{sector}}{B}(r) = \pm 0.5 \cos(45^\circ) \sigma_{injection} r_{injection} / r$$

The available sector coils can reproduce partially the theoretical corrections (Figure 7).

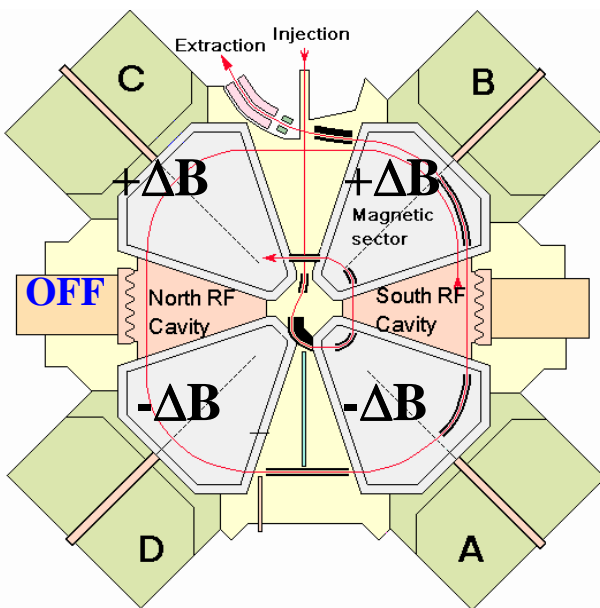

Figure 7: Magnetic field modifications on the SSC ($\pm\Delta B$) to allow the beam extraction with one RF cavity acceleration

A machine study was done to find a SSC tuning to be able to accelerate beam to physics with one cavity off. An excellent transmission has been reached (90 %). This is satisfactory from the operation point of view, and maybe this tuning will be useful if a new water leaks occurs in the RF cavities.

In-Flight Separation techniques (IFS)

Since October 1994, a device called SISSI (Superconducting Intense Source for Secondary Ions) has been used to produce secondary radioactive beams [3]. A

0.4 mm diameter spot is created on a thick rotating target with a superconducting solenoid with a maximum field of 11 Teslas. A second identical solenoid is placed after the target to improve the downstream beam line angular acceptance and thus increases the collection of the secondary ions. The cooling is provided by a circuit of liquid helium at 4.6 K. The target is a 2000 rpm rotating disk, so that the radiated heat is spread over a much larger area than that of the beam spot..

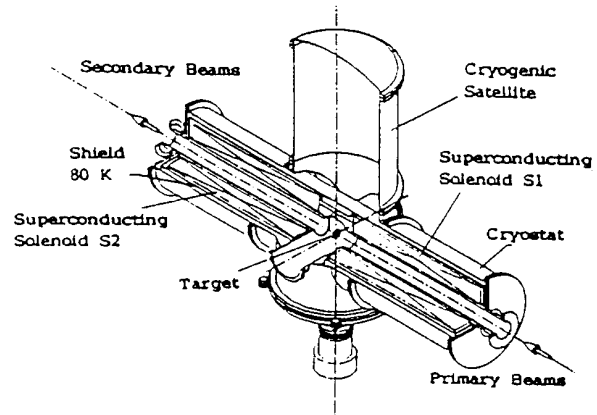

Figure 8 : Schematic view of the cryostat of SISSI.

In June 2007, the second solenoid quenched and cannot be used. The reasons of the repetitive quenches are not known (ageing, device weakness, neutron effects ...). Therefore studies have been launched to overview all possible solutions to produce secondary beams (alternative solutions, repairing) compatible with the operation schedule and resources.

DEVELOPMENTS

The SPIRAL strength can be summarized by:

- Large Energy range of post-accelerator : from 1.2 MeV/A to 16 MeV/A (for Q/A=0.25)
- Mass purification of the cyclotron R= few 10^{-4} , Good energy definition of the CIME beams $\Delta E/E < 5 \cdot 10^{-3}$
- Good transmission for such an accelerator technology (20%-40%).
- Great target-source selectivity + cyclotron purification giving a pure beam of most of available ion beams.
- 40 isotopes available.
- Possibility to run detectors developments with stable beam of CIME in a stand alone operation.

But SPIRAL has also its limitations

- Still, few radioactive ion species are available (He, O, N, Ne, Ar, Kr, F).
- Intensity is a parameter of utmost importance; It is the main limitation for most of experiments.

- The large turn number in CIME impacts the beam emittance: $\Delta T_{FWHM} < 2\text{ns}$ and emittance $\sim 16\pi.\text{mm.mrd}$ imply multi-turn extraction.

Let us note that figures were predicted before construction. In the experimental rooms the observed bunch length $\Delta T_{FWHM} = 3\text{-}5\text{ ns}$ is dominated by the effect of the very long beam line with low energy ions, not by the CIME properties itself.

In the following is reviewed the evolutions machine-side to take into account the previous limitations and more.

Improvement of the identification station

The Identification station of SPIRAL is a powerful and flexible tool for the identification and counting of very low intensity radioactive beam produced.

However in the case of routine intensity measurement of a radioactive beam dedicated to post acceleration ($10^3\text{-}10^6\text{pps}$) which represent the main part of the activity of the station, the system was suffering with a lot of stability problems and was not user friendly. These characteristics were very demanding in manpower.

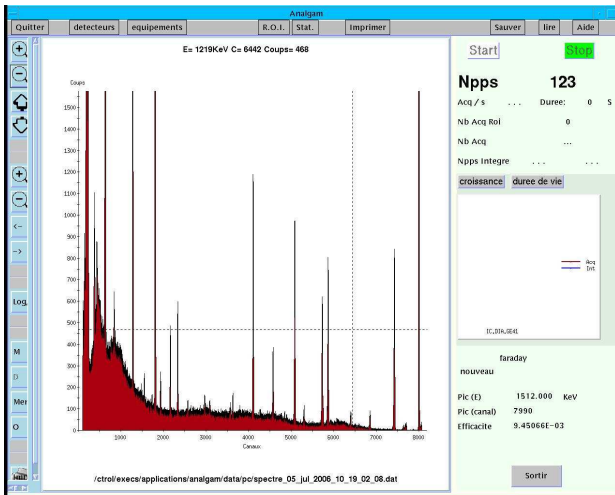

Figure 9: Gamma rays observed with the new software in the identification station. Efforts have been done in 2006 to make the station “user friendly”. The previous system relying on labwiew+GANIL acquisition+ server developed from 2001 to 2006 is still available

An alternative acquisition system for germanium, silicon and plastic scintillator detectors, with its own software, has been developed which eases the use and the maintenance of the whole system. The developed software is integrated in the control system of the accelerator. The identification can be realised on-line with life-time and intensity measurement. This system has been developed in the first part of 2006.

Development of a 1+/N+ set-up for the production of multi-charged radioactive alkali ions

In the framework of the production of radioactive ion beams by the isotope separator on-line (ISOL) method, a new system has been developed at GANIL/SPIRAL1 to produce multi-charged alkali ions. The principle, referred to as the “direct 1+/N+ method”, consists of a surface ionization source associated with a multi-charged electron-cyclotron-resonance ion source without an intermediate mass separator [4]. This new system has been tested on line using a ^{48}Ca primary beam at 60.3A MeV. The experimental evidence of the direct 1+/N+ process has been obtained for a potential difference between the two sources of 11 V, and with a 1+/N+ charge breeding efficiency of 0.04% for $^{47}\text{K}^{5+}$. This value is significantly lower than the value of 6% obtained for stable K ions with the standard 1+/N+ method.

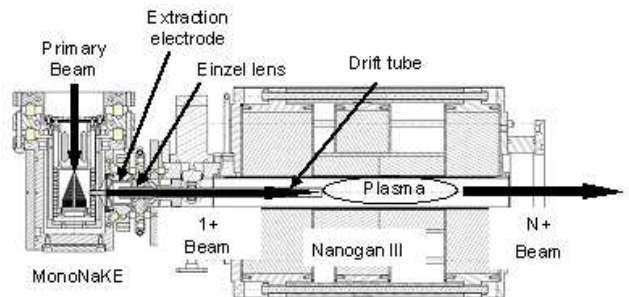

Figure 10 : surface ionization source associated with a multi-charged electron-cyclotron-resonance ion source

The challenge of such a target-source as well as the metallic ion source, is of great importance for the development of SPIRAL experiments. The physicist community requires this SPIRAL beam evolution. The theoretical and experimental studies are under way.

CIME Inflector

By conception, the whole range of energies is covered by using two different types of inflector to inject the beam into CIME to be accelerated.

- Muller inflector for the harmonic 3 and 2
- Spiral inflector for the harmonics 4 and 5 (and now 6)

Therefore, shifting from a high energy experiment to a lower one may oblige to exchange the deflectors which required about 2 days of intervention with an intervention on the RF cavity extremities. In order to avoid a waste of beam time, extension of the inflector capabilities was studied. Currently, the Muller inflector covers the harmonic 4, 3 and 2, while the Spiral inflector covers the harmonics 6, 5, 4 and 3.

Irradiation control of Spiral Target

The initial safety criterion for the irradiation of the production target was to not exceed 15 days of irradiation, whatever the beam intensity sent onto the target. This criterion appears to be a strong limitation: since, it imposed to change very often the target, inducing a lot of unnecessary nuclear waste handling. A new criterion has been defined with safety authority, in order to take account of the fluence (the flow of ions integrated over the lifetime of the target). It makes it possible to optimise the availability of this device and decreases the frequency of the handling operations likely to generate radiological risks. In operation, the respect of the criterion is done by measurement of the fluence. The detector is a dedicated device, a beam transformer, functioning permanently for the periods of operation of SPIRAL.

Working diagram extension

Even with a large range of energies, the interest of several physicists turned to lower energies, below the limits specified. Simulations and machine studies allowed to reach 1.2 MeV/A instead of 1.7 MeV/A (Figure 5) by accelerating the beam on the harmonic 6 of the RF cavities. The yields out of CIME were acceptable and an experiment using ^{15}O was then possible. Lower energies might be reached but probably with poor yields. Higher energies (16-25 MeV/A) are less demanded because of the source limitations and the difficulties to obtain $Q/A > 0.25$.

Low Energy radioactive Beams

A beam line permits the delivery of radioactive beams from SPIRAL at low energy (30 kV plate-form) to a

specific experimental apparatus: a RFQ gas cooler connected to a Paul trap. The beam line was constructed in 2003 and the first beam tests were realized in 2004. Two experiments to study β - ν correlations in the decay ^6He have been done in order to test the limits of the Standard Model in 2005 and 2006.

GANIL-SPIRAL Looking Toward the Future

A new machine, SPIRAL2, is about to be constructed on the GANIL site [5]. The post-acceleration of the exotic beams produced will be done by the actual cyclotron CIME from SPIRAL1. Therefore, new safety requirements have to be applied and new constraints taken into account from the new exotic beams accelerated. In this frame, new projects were launched such as new access control, improvement of the SPIRAL1 equipments reliability, new transfer line,

REFERENCES

- [1] http://www.ganil.fr/operation/available_beams/available_beams_tabular.htm
- [2] http://www.ganil.fr/operation/available_beams/radioactive_beams.htm
- [3] A. Savalle, et al. , "The SISSI facility at GANIL", Sitges, June 1996.
- [4] C.Eléon et al., Proceedings of EMIS07, Deauville, FRANCE, 24th-29th June 2007 to be published
- [5] P. Bertrand, "The advancement of SPIRAL 2 project", this conference.