



## Superconducting booster cyclotron studies at GANIL

C. Bieth, P. Bricault, A. Chabert, M. Duval, J. Fermé, A. Joubert, M.H. Moscatello, F. Ripouteau

► **To cite this version:**

C. Bieth, P. Bricault, A. Chabert, M. Duval, J. Fermé, et al.. Superconducting booster cyclotron studies at GANIL. EPAC 90 - Second European Particle Accelerator Conference, Jun 1990, Nice, France. pp.431-433, 1990. <in2p3-00665611>

**HAL Id: in2p3-00665611**

**<http://hal.in2p3.fr/in2p3-00665611>**

Submitted on 2 Feb 2012

**HAL** is a multi-disciplinary open access archive for the deposit and dissemination of scientific research documents, whether they are published or not. The documents may come from teaching and research institutions in France or abroad, or from public or private research centers.

L'archive ouverte pluridisciplinaire **HAL**, est destinée au dépôt et à la diffusion de documents scientifiques de niveau recherche, publiés ou non, émanant des établissements d'enseignement et de recherche français ou étrangers, des laboratoires publics ou privés.

## Superconducting Booster Cyclotron Studies at GANIL

C. Bieth, P. Bricault, A. Chabert, M. Duval, J. Fermé  
A. Joubert, M.H. Moscatello, F. Ripouteau

GANIL - B.P. 5027 - F-14021 Caen cedex

**Abstract :** Work is beginning at GANIL on the study of a booster cyclotron SSC3 giving a maximum energy around 500 MeV/A for light ions . SSC3 could be a separated sector cyclotron using superconducting coils. First results concerning these studies are reported.

**Introduction :** The GANIL facility provides ions from C to U at maximum energies and intensities ranging from 100 MeV/A,  $10^{13}$  pps for light ions down to 25 MeV/A,  $5.10^9$  pps for the heaviest ones.

Among various possible developments of our laboratory, it would be very fascinating to increase the maximum energy in the 500 MeV/A range while preserving the beam intensities and still improving its qualities. New very promising research fields would be opened by these beams of high intensity in the hundreds of MeV/A range.

A new separated sector cyclotron is of course the booster suited to this goal and we started a study with the aim to know if it is technically feasible and economically worth to use a superconducting technology for such a post accelerator.

### Main parameters and description of SSC3

The main ejection radius ( $\bar{r}_{out} = 3m$ ) and the RF frequency range ( $f = 7 - 13.36$  MHz, 2<sup>nd</sup> harmonic) of SSC2 being given, it turns out that the ratio of SSC3 ejection to injection radii has to be larger than 1.8 in order to reach 500 MeV/A.

We have chosen  $\bar{r}_{out} = 2 \bar{r}_{inj}$  and restricted the SSC2 frequency range to 7 - 12 MHz when injecting into SSC3. The SSC3 maximum energy will then be 490 MeV/A and will be reached at  $\bar{B} \cdot \bar{r} = 7.144$  T.m for  $Q/A = 0.5$  ions, we will also limit the maximum SSC3 rigidity to this value.

From these choices, we deduce the SSC3 energy range versus  $Q/A$  as shown on figure 1.

Beam characteristics in a perfect machine and using the usual approximations are deduced and reported in table 1.

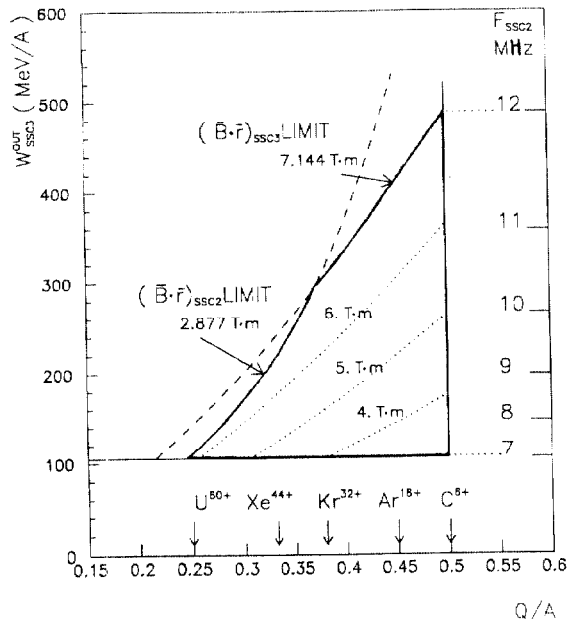

Figure 1 :  $W(Q/A)$  range of SSC3

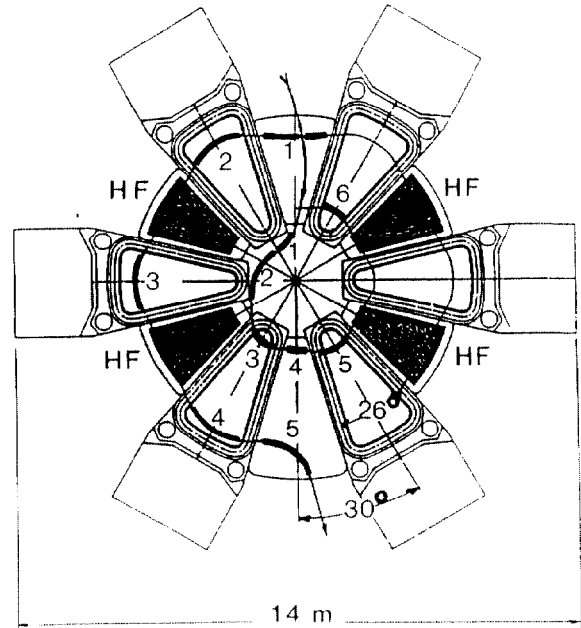

Figure 2 : sketch of SSC3 including the 6 injection and the 5 ejection elements

Synchronism between the two cyclotrons SSC3 and SSC2 implies  $\bar{r}_{inj} = 1.5 h/k (f_{SSC3} = k f_{SSC2})$ . In order to keep  $\Delta\varphi < 5^\circ$  (rebuncher size),  $k$  is restricted to values  $\leq 4$  and due to the efficiency of the double gap cavities we will use, the value of  $h$  has to be chosen between 4 and 12 ( $\sin h\delta \geq 70\%$  with  $\delta = 10 - 12^\circ$ ).

From these considerations it results  $\bar{r}_{inj} \geq 1.5$  m and a moderate averaged maximum field  $\bar{B} \leq 2.4$  T favouring a totally separated sector magnet using superconducting coils around each pole. Such a solution was first studied at Munich (1).

The  $v_r - v_z$  patterns for hard-edge radial sectors are well known (2). Due to the enhancement of the field flutter from the separated superconducting coils,  $v_z$  is increased so that a 6 radial sector geometry ( $\leq 26^\circ$ ) seems rather well appropriate although the crossing of the  $v_z = 1$  resonance could lead to some difficulties and has to be carefully checked.

It will be possible to place 4 double gap cavities (500 kV, 200 kW each) giving a turn separation  $\approx 3$  mm at the ejection radius of 3.75 m which we have selected for our feasibility studies. The main parameters of such an SSC3 are given in table 2 and a sketch of the machine displayed on figure 2.

Ion range	C <sup>6+</sup>	↔	U <sup>60+</sup>
Q/A	1/2	↔	1/4
W <sub>min</sub> MeV/A		←105→	
W <sub>max</sub> MeV/A	490	↔	110
N ions/s	$10^{13}$	← (≠ N <sub>SSC2</sub> ) →	$5.10^9$
ε <sub>r-z</sub> mm.mrad		← ≤ 2π →	
ΔW/W Full width		← ≤ 5.10 <sup>-3</sup> →	
Δφ Full width		← 10° →	

Table 1 : Expected SSC3 beam characteristics

6 sectors : 26° between radial axes of the coils	
mean radii (m)	injection $\bar{r}_{in} = 1.875$
	ejection $\bar{r}_{out} = 3.750$
mean field at ejection (T)	: $1.905 > \bar{B}_{out} > 0.812$
mean field increase (%)	: $8.6 \leq \bar{B}_{out}/\bar{B}_{in} \leq 41$
4 RF double gap cavities : 20 - 24° between gap axes	
Frequency range : 28 - 48 MHz	
Maximum voltage at 48 MHz : 500 kV ( $\leq 200$ kW)	

Table 2 : CSS3 main parameters (feasibility studies)

**Magnetic structure**

Each of the six sector magnets consists of two superconducting main coils (around the poles), room-temperature iron pole pieces and a large yoke.

Due to the large range of energy and ion species, the required field laws are very different and for the most difficult operating point, the induction between the injection and ejection radius raises by about one Tesla. As a consequence, correction coils must provide a high field value and one peculiarity of the machine will be to work with superconducting trim coils.

A set of warm conductors, located between the beam and the cryostat vacuum chambers is also foreseen to provide small adjustments of the field pattern.

The global conception of a sector magnet is designed according to the following main options :

- room-temperature poles,
- main coils and superconducting trim coils enclosed in the same cryostat,
- direct mechanical link between the upper and lower main coils,
- top and bottom of the magnetic vacuum tank closed by the magnetic circuit.

The preliminary technological study of the cryogenic parts (coils and cryostat) has been performed in Saclay (Service des Techniques Instrumentales des Particules Élémentaires).

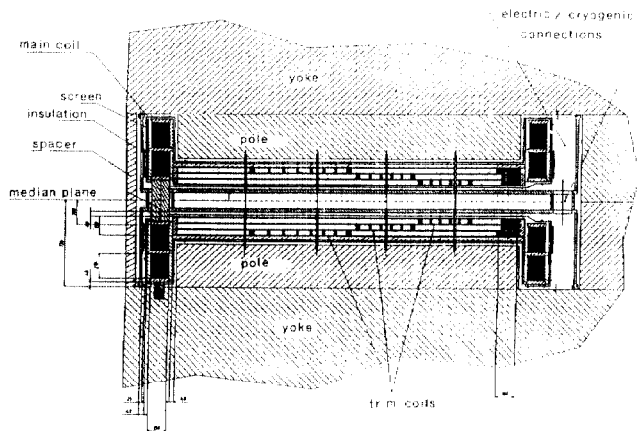

Figure 3 : Layout of the poles structure

**Main coils** : The coil made of 12 double pancakes has a section of 150 x 420 mm<sup>2</sup>. The overall current density is 40 A/mm<sup>2</sup>, well below the technological limits but chosen for stability and protection reasons.

The magnetic forces, calculated with TOSCA, tend to make the coil circular and the strongest one reaches 8000 N along the straight side.

A solution with hollow conductors has been chosen. It allows to realize a classical winding, impregnated under vacuum and pressure with epoxy resin, more favourable than the bath system to hold the forces.

Cooling is provided by forced flow of supercritical helium. The coil is placed inside a thick stainless steel box divided in two parts for strengthening.

All long and between the straight sides of this box, a plate gives a maximum stiffness.

Computed mechanical behaviour with such a structure gives a maximum radial deformation of 3 mm.

The tolerances haven't been studied yet. It will be necessary to define the field perturbations introduced by the geometrical defects and their influence on the optics.

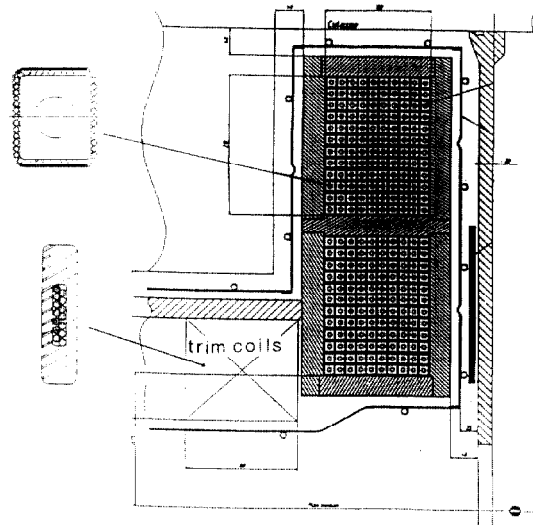

Figure 4 : Cross section of the coils

**Correction coils** : The field shape (isochronous field) is mainly obtained by means of a set of superconducting coils.

These trim coils are located inside the main coils, in three layers.

In spite of the lower efficiency (smaller magnetic angle) this configuration is chosen in order to put the main coils as close as possible to the median plane.

The conductors are distributed according to the field variation law. This method is very attractive, minimizing the number of currents whose connexions require a lot of room.

With only three independant currents, corresponding to each layer, we managed to fulfill the requested field pattern for any field level and energy.

The residual corrections to be applied are small enough to be obtained with classical warm trim coils.

Moreover, a set of "nose" conductors are added to compensate for both the negative return flux produced by the trim coils and the natural base field fall off.

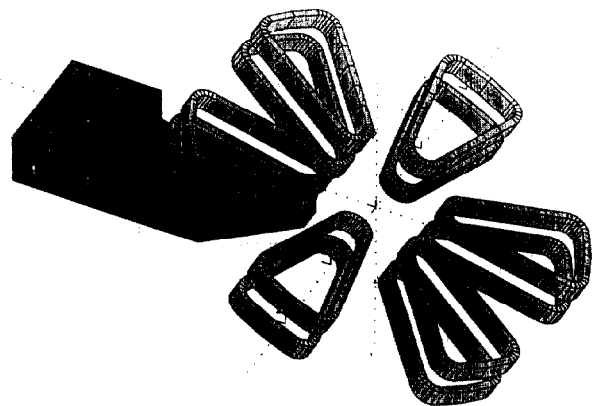

Figure 5 : Display of the elements in TOSCA

**Field calculations :** The field calculations are performed using the three dimensional computer code TOSCA.

In order to take their reciprocal influence into account, the six sectors are introduced according to figure 5.

As an example of the results, figure 6 shows the field along the axis of the sector.

Figure 7 shows the field at a given radius ( $\bar{r} = 3\text{m}$ ) from the sector axis to the valley axis.

On these figures, we can see that the reverse field in the valley is typically 0.5T.

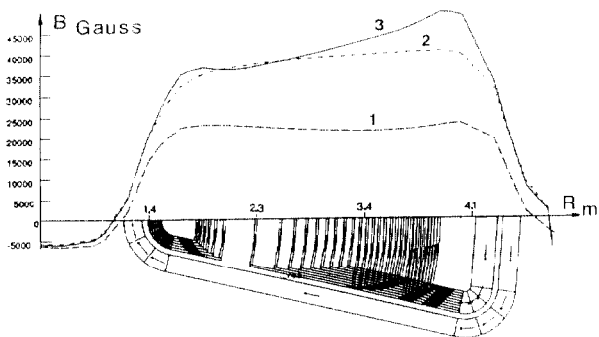

Figure 6 : Curve 1 : field generated by the main coils only  
Curve 2 : field obtained with main coils and iron  
Curve 3 : isochronous field for  $^{12}\text{C}^{6+}$  at 488MeV/A

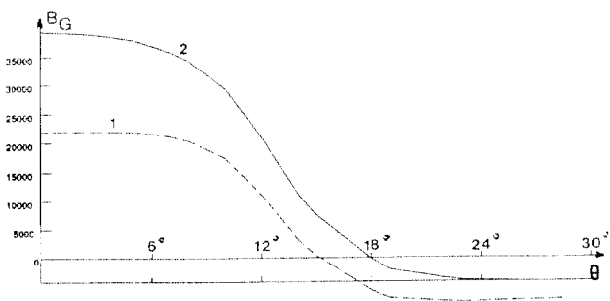

Figure 7 : Curve 1 : main coils alone, without iron  
Curve 2 : main coils + iron

**Main characteristics of a sector magnet**

Weight	375 t
Iron gap	700 mm
Max field	5 T
Stored energy	40 MJ
<b>Main coil (one coil)</b>	
Ampere turns	$2.4 \cdot 10^6$
Max intensity	10000 A
Overall current intensity	$40 \text{ A/mm}^2$
12 double pancakes of 2 x 10 turns	
Total number of turns	240
Proposed conductor : 54 wires Cu-NbTi	
Diameter 1 mm - Cu/Sc = 1.3 - around a rectangular tube 12.2 x 14.3 mm <sup>2</sup> , $\phi 7$ mm	
<b>Trim coils (one set)</b>	
Ampere turns	400000
3 layers of 8 groups of conductors	
each group constituted of 8 elementary conductors	
Max intensity	2500 A
Overall current density	$25 \text{ A/mm}^2$
Proposed conductor : 14 wires (same type as for main coils)	
inside an Al stabilizer of 5 x 20 mm <sup>2</sup>	

**Injection and ejection systems**

The elements shown in figure 2 have the following characteristics :

<b>Injection</b>	1	Superconducting Magnet	3 T
	2	Superconducting Magnet	2.5 T
	3	Superconducting Septum Magnet	2 T
	4	Magnetic Septum	0.3 T
	5	Magnetic Septum	0.3 T
	6	Electrostatic Septum	60 kV/cm
<b>Ejection</b>	1	Electrostatic Septum	90 kV/cm
	2	Electrostatic Septum	60 kV/cm
	3	Magnetic Septum	0.3 T
	4	Magnetic Septum	0.3 T
	5	Superconducting Magnet	5 T

Most of these elements must be movable, both in injection and ejection systems. Moreover, we have to use a precession effect in order to get enough turn separation for a single turn extraction.

**Accelerating cavities**

We have chosen double gap cavities well adapted to the frequency range and able to sustain high voltages. The main tuning is provided by sliding short circuits, capacitive pannels being excluded at these voltage levels.

First calculations show no major problem to fulfill our requirements. A sketch of such a cavity is shown on figure 8.

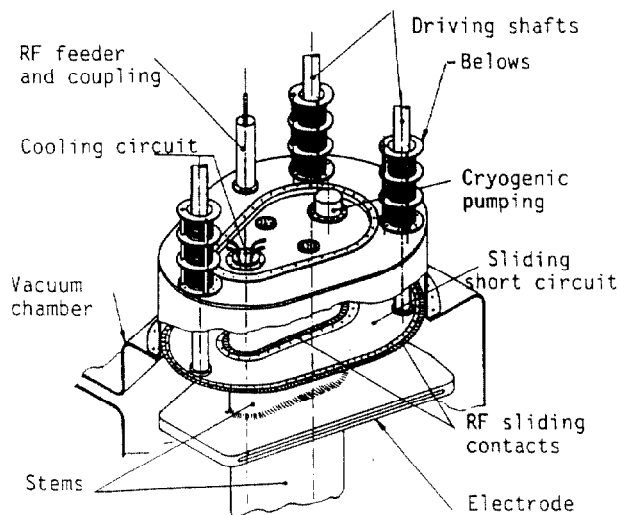

28 - 48 MHz — 500 kV — 200 kW

Figure 8 : Sketch of an accelerating cavity

**Conclusion**

Up to now, our preliminary studies led us to the solution here exposed. Many detailed design questions and technological problems will have to be solved, especially concerning injection and ejection elements, and the tolerances have to be determined.

**References :**

- (1) Design status of the Munich cyclotron Suse  
U. TRINKS and al - IEEE taansactions on Nuclear Science - Vol NS - 30, No4. August 1983
- (2) Orbit properties of the isochronous cyclotron ring with radial sectors  
M.M. GORDON - Annals of physics, 50 - p 571 - 597 (1968)