

## A SECONDARY EMISSION-MULTIWIRE CHAMBER FOR GANIL HEAVY ION BEAMS TUNING

R. ANNE, M. VAN DEN BOSSCHE.

GANIL B.P. 5027-14021 CAEN Cedex. France

### Summary

We present a secondary emission-monitor based on a multiwire chamber, providing beam profile measurements. It has been designed for the extracted beams of GANIL, and tested particularly at ALICE (I.P.N. Orsay) with different heavy ions, such as oxygen and argon, for beam intensities between 10 and 800 nA. The secondary emission yield being important for low and medium energy heavy ions, the size of the wires has been reduced to 10  $\mu\text{m}$ , nevertheless providing a measurable signal. The profiles can be displayed on a scope or processed by a microprocessor, allowing calculations of beam characteristics such as the beam emittance.

### I. Introduction

In the development of the GANIL, the need for a fast position, width, and emittance measuring device was recognized early, owing mainly to the very long beam lines between the two cyclotrons and to the experimental areas. So we have designed and developed an intercepting beam profile monitor based on the well known secondary emission phenomenon under the passage of charged particles, mainly of low and medium energy heavy ions. This monitor is intended to be used during tuning periods, so it is retractable, but we hope, since it represents a low mass and does not disturb the beam too much (transparency per plane is 98 or 99%), to use it in continuous operation.

### II. Multiwire chamber mechanical description

An exploded view of the chamber assembly is depicted in figure 1 a and 1 b.

The chamber works in the vacuum of the beam line and consists of two orthogonal signal-wire-planes interleaved between three HV 0-rings. Each sensitive wire-plane is composed of a 48 wire-grid, soldered on an epoxy-fiberglass or a teflon-glass printed-board. The wires are 10 or 20  $\mu\text{m}$  gold-plated-tungsten, spaced 0.5, 1.0 or 2.0 mm apart.

The three positively biased HV rings adjacent to the secondary emission-grids provide a clearing field for secondary electrons. Figure 2 reports the signal amplitude for various 0-ring high voltages.

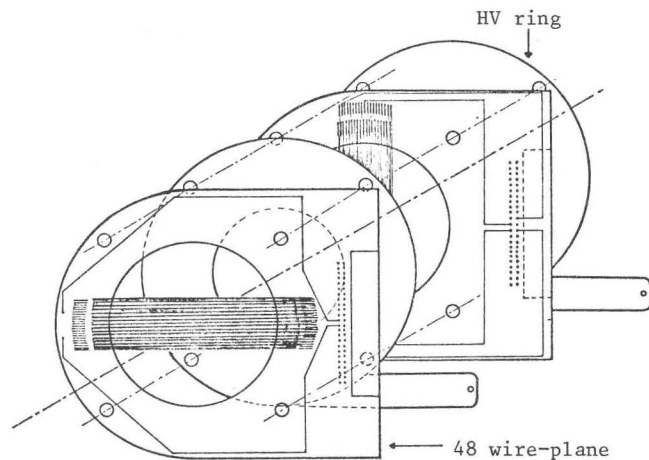

Figure 1 a.

Wire-planes and HV 0 Rings are held by an inox frame. (See figure 1 b). The rotation of the whole gives the positions "out" and "in" of the chamber.

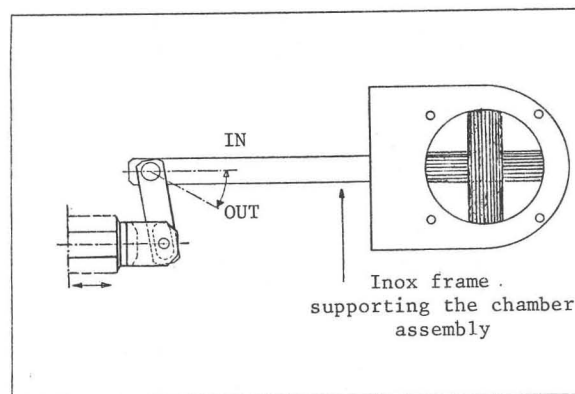

Figure 1 b.

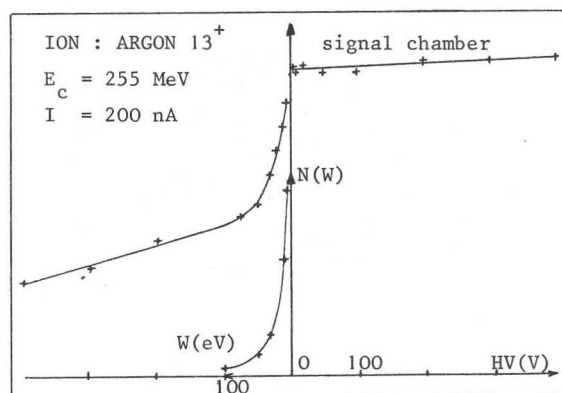

Figure 2.

### III. Electronics

The analog read out is obtained by connecting a capacitor between each wire and ground, thus integrating the charge left by the passage of particles hitting the wire. To get the beam profile, the voltage on each of the 48 capacitors is measured in turn by switching it through a "F.E.T. multiplexer" to a read out bus, which is either directly connected to an oscilloscope for display or to a CAMAC unit where data are handled by a micro-processor under the direction of the central control computer. We expect to use these electronics for relatively intense beams (between  $10^{10}$  and  $10^{13}$  particles per second). For lower intensities, electronics with an operational amplifier per wire is intended to be used. A prototype has been tested which allows the display of a beam-intensity as low as 1 nA.

Figure 3 is a block diagram of the electronics processing the secondary emission signal.

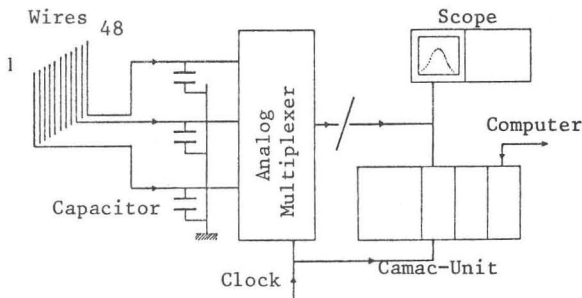

Figure 3.

IV. Results

a) Beam profiles :

Some beam-profiles representing a simultaneous measurement of the vertical and horizontal spatial distributions of the beam are shown in figure 4.

One may calculate the beam position, its width and also the integral under each histogram, which is proportional to the beam intensity, so that beam-flux measurements can be made by means of this detector.

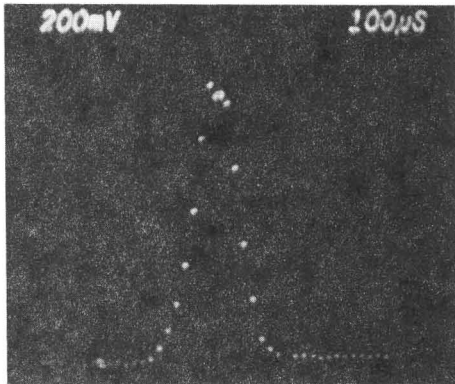

Oxygen 5+, E = 52 MeV, I = 400 nA  
Tandem Saclay

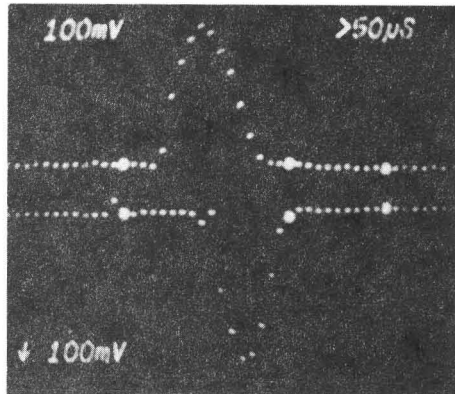

Horizontal and vertical beam-profiles.  
Figure 4.

b) Signal versus beam intensity :

Figure 5 is a plot of the chamber signal versus beam current intensity ; it proves, as expected, it can be used for relative calibration operations. For example, with several monitors placed along a beam-line, particles losses can be easily estimated.

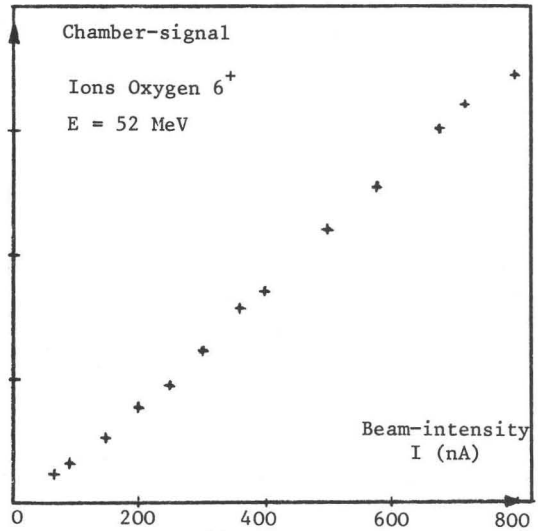

Figure 5.

c) Use of the profile monitor in a beam emittance measurement :

One of the initial motivations for the development of this monitor was for use in a beam emittance measurement, since most of the emittance measure methods require beam profile widths. The parameters of orientation and area of the phase space can be calculated by using three beam widths measured either on three monitors along a drift-space or on a single one located downstream. With Q-poles allowing variations of the beam focus up to the monitor, this latter method is known as the "3 gradient method."

We have developed a mean-square-emittance measure program running with the latter method, taking 10, 15, or 20 profile widths, improving the emittance measurement. Figure 6 reports on an emittance measure made at ALICE (I.P.N. Orsay).

Further improvements will come through better knowledge of the secondary emission yield under the passage of heavy ions, versus ion nature, energy, and incident charge.

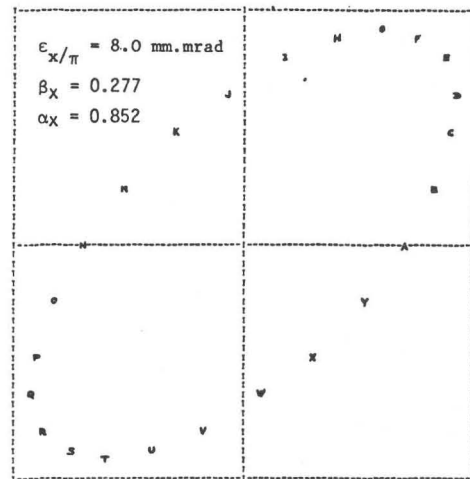

Fig.6

Horizontal beam-emittance

Ions : Argon 12+, E<sub>c</sub> = 232 MeV, I = 8.10<sup>10</sup>

We would thank Mrs A. Lefol, G. Milleret, R. Perret and A. Trogno for their help and support during data-acquisition.