

MAIN BEAM DIAGNOSTICS AT GANIL

F. Loyer, J.M. Loyant, M. Promé; Mechanical Group; R. Anne, R. Berthelot, Y. Georget, M. Van Den Bossche.

Grand Accélérateur National d'Ions Lourds, B.P. 5027, 14021 CAEN Cedex, France
Tel (31) 94 81 11 - Telex 170533 F.

Abstract. - The main diagnostics designed at GANIL are :

- a probe in 3 yokes of each SSC. The pick-up probe consists of differential interceptive targets for the measurement of the vertical and radial beam positions and a semi-interceptive wire target, using secondary electron emission, for the measurement of the time-length of the bunches. The pick-up probe is supported by a tube which moves through the yoke ; it covers a 2.5m range.
- central phase diagnostics - 15 couples of 50 ohm capacitive probes are located in one valley of each SSC. They mainly allow to adjust the isochronism by measuring the central phase of the beam. 8 high impedance capacitive probes are located in the beam line. They measure the beam phase in order to control the RF phase of the accelerating and bunching voltages. The phase measurement is made on the second harmonic of the beam signal with an analogic multiplier between the beam signal and the pilot. Amplifier gain, fundamental rejection filters, noise rejection and other parameters are microprocessor controlled according to the magnitude of the picked-up signal and the working frequency.
- profile monitors - The GANIL extracted beam is going to be tuned with the help of secondary emission monitors. They are multiwire chambers operating in the beam line vacuum. They provide two simultaneous beam profiles in the vertical and horizontal planes. The profiles are displayed on a scope or processed by a Camac-unit. They give informations on the location, width, emittance and intensity of the beam. The number of monitors for the whole CANIL is about 80.

These diagnostics have been tested at GANIL (ion source, that means to very low energy beams, and injector extracted beam), at ALICE and at ISN cyclotron.

A: MAIN BEAM DIAGNOSTICS FOR THE SSC ⁽³⁾

1. **Introduction.** - Three measurements are necessary to determine the SSC orbit position (center, beam envelopes,...). This is achieved with three probes which measure the radial and vertical beam position. Their location has been chosen to allow also the determination of the beam position in the vicinity of extraction magnetic elements (1 and 2 of figure 1).

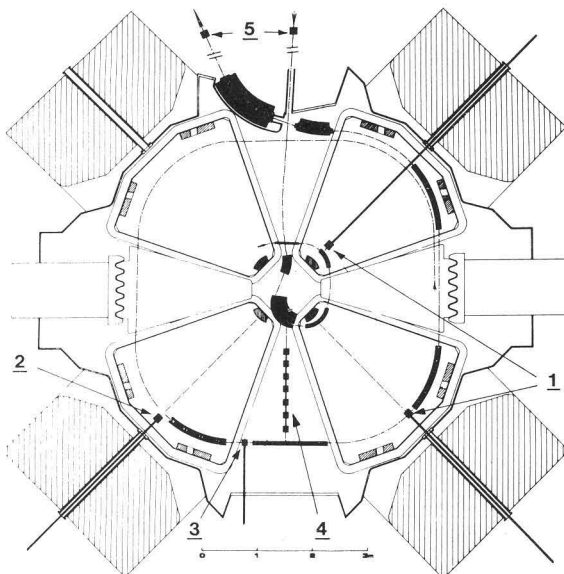

Fig. 1: Diagnostics for the SSC :

1 : Beam radial and vertical position, 2 : Beam radial and vertical position and phase extension, 3 : Beam position, 4 and 5 : Beam central phase.

The phase extension of bunches is measured by a probe installed on the same support as the beam radial position (2 of figure 1).

To adjust the isochronism and the phase compression, it is quite necessary to know the beam central phase from injection orbit to extraction orbit. This parameter can be extracted from the phase extension probe signal. Nevertheless, since this method leads to a destructive measurement, 15 fixed capacitive probes are installed along a radius to allow a non destructive measurement (4 of figure 1).

The beam central phase as compared to RF cavity phase of SSC and buncher must be kept in tight tolerance (less than .5°). It is permanently controlled by 8 capacitive probes set in beam lines.

To avoid noise effects on fundamental RF frequency, the phase measurement is performed with the second harmonic. Therefore, the beam central phase at GANIL is defined as the second harmonic phase of bunches.

2. **Yoke probes.** -

2.1. **Mechanical description.** (See figure 2)

The pick-up head (10) covers about a 2.5 m range along a magnetic axis from injection orbit to extraction orbit. It is supported by a tube (1) which moves through the yoke (2). This tube (6.3 m long) is moved by a ball-screw system (4) activated by a stepping motor (5) controlled by Camac⁽¹⁾.

The vacuum tightness is achieved by a 3.3 m long bellow played on the console oscilloscopes (Fig. 5). The 12 parts of this bellow are controlled in position during the compression by a sort of pantograph(7).

The figure 2 shows the device :

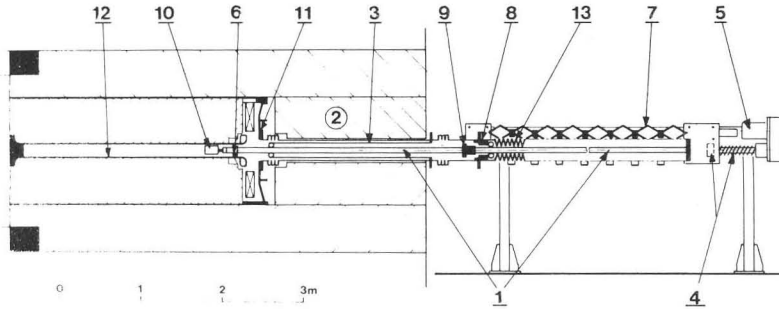

Fig. 2: Yoke Probe.

2.2. Beam position electrode.

Figure 3 shows the head fixed on the end of its tube (1).

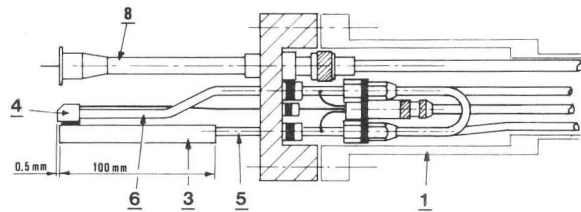

Fig. 3: Yoke probe head.

The beam position electrode consists in 3 fingers (4) jutting .5mm out of a main target (3). This allows to measure the beam radial density and the orbit positions. Beam vertical position can also be estimated. The electrode current can be displayed on the main console in analog form on galvanometers and oscilloscopes or in digital form on T.V. monitors (1-2).

2.3. Bunch length measurement device.

This device is supported by the same tube than one of the beam position electrodes (8 on Fig.3). It intercepts about 20% of the beam. The device consists in a 50 ohm coaxial tube terminated by a sort of comb made of 15 golden tungsten wires (Fig. 4). The even wires are connected to the inner conductor of the coaxial and the odd ones to the outer conductor.

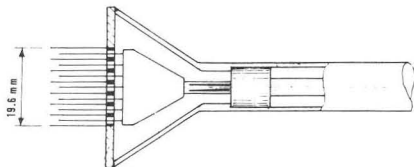

Fig. 4: Phase extension device of yoke probe.

The RF signal is the superposition of three currents which are induced by :

- a) the charges of ions which hit the even wires
- b) capacitive effect induced by ions passing between wires.
- c) secondary electrons which are extracted by a negative bias of the even wires, in spite of the magnetic field when this bias is sufficient.

Tests with 300 KeV deuteron and 5 MeV/A carbon beam confirm the good behaviour of this device.

The pick-up signal, after amplification, is split in two directions : one to the central phase measurement unit (see 3.3) and one to a home-made sampling unit to be displayed on the console oscilloscopes (Fig. 5).

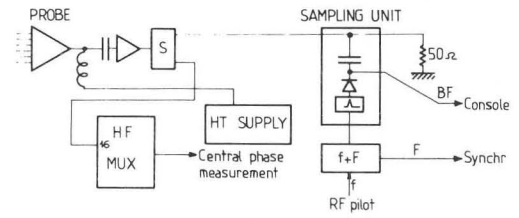

Fig. 5: Phase extension measurement process.

3. Central phase diagnostics.-

3.1. SSC probes.

For each SSC, 15 couples of capacitive electrodes are located along a radius in the valley opposite to the injection (fig.1). They are fixed on 2 tubes (upper and lower), cables running inside. These electrodes (10cm x 10cm) are 50 ohms matched. Their signals are selected by two RF multiplexers 16 -1 then upper and lower signals are summed for the phase measurement.

The sensitivity of these electrodes (independent of the electrode radial position) should be 150 to 300 $\mu\text{V}/\mu\text{A}_e$ (2nd harmonic level).

3.2. Beam line probes.

They are cylindrical electrodes, without ground electrode. Their length is 10 cm and their diameter 8 cm. They are charged on high impedance. The sensitivity should be 125 $\mu\text{V}/\mu\text{A}_e$ (2nd harmonic level) for 10 MeV/A beam. (inversely proportional to energy).

3.3. Phase measurement unit.

Measuring the phase directly on the 2nd harmonic electrode signal with a synchronous detector has been chosen.

The figure 6 shows the analog processing :

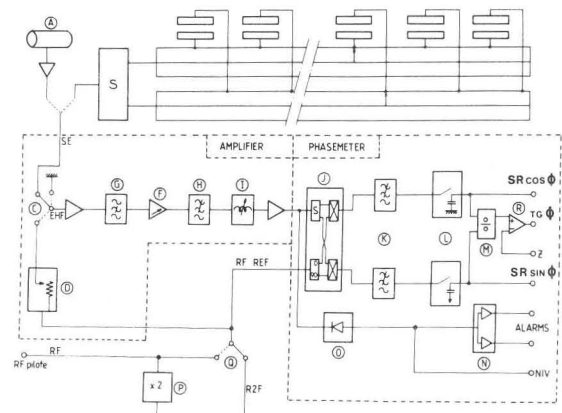

Fig. 6: Central phase measurement process.

- A: beam line electrode with its high impedance amplifier.
- B: SSC electrodes with their multiplexers and combiner.
- P: frequency doubler
- C: switch which selects the input
- F: programmable gain amplifier
- G: rejection filter to reduce the fundamental frequency noise. They are made of cable delay lines.
- I: cable delay line to turn the phase (see M)
- J: electronic unit which provides $\text{SR} \cos \phi$ and $\text{SR} \sin \phi$, ϕ being the phase between electrode signal SHF and reference signal (R2F), S the level of SHF and R the level of R2F. This is made with two analog multipliers.
- O: level detector.

N: alarm circuit for $SHF < -30$ dBm and $SHF > -10$ dBm
L: sample-and-hold synchronized on the source pulse.
M: analog divider which gives $tg \phi \approx \phi$ if ϕ is small.

This whole device is controlled by a JCAM10 microprocessor. Three tasks are programmed (for each probe):
. initialization : filter adjustment, checking
. absolute measurement : $\cos \phi$ and $\sin \phi$ by double weighing (with and without beam)
. relative measurement : performing of $tg \phi \approx \phi$ and sending it to RF phase central process.

The measurement resolution is limited by the noise to signal ratio which is equal to phase resolution (in radian). For instance, the estimated phase resolution of SSC probes should be 1° (bandwidth = 1 kHz) for 10 nA_e beam or 1° (bandwidth = 10 Hz) for 1 nA_e. This is confirmed by several tests on other cyclotrons (Orsay, Grenoble).

B: PROFIL MONITORS FOR THE BEAM LINES

1. Introduction.- This secondary emission monitor is able to operate in a large energy range, namely from a few KeV/A to 100 MeV/A. So it will be used as a standard device along the whole GANIL beam transport, i.e., from the injector to the experimental targets. Preliminary tests have been made on different accelerators and results obtained particularly around ALICE are reported in a previous paper (4).

Our purpose here is to present the up to date monitor and GANIL related, measurements.

2. Description of the Mechanical part.- (Figure 7)

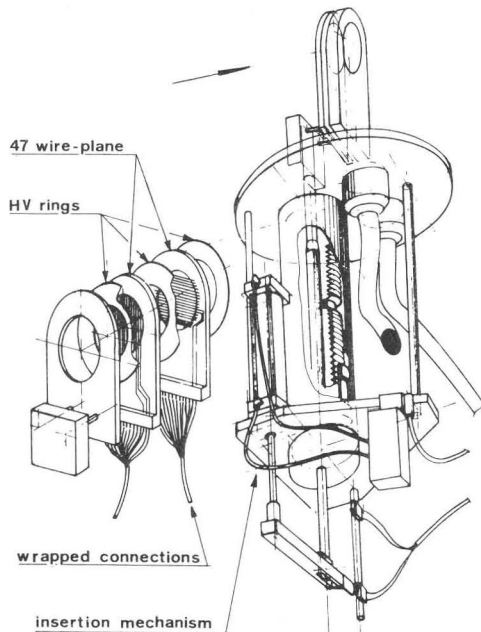

Fig. 7: Mechanical part.

The chamber consists of two orthogonal wire-planes interleaved between 3 high voltage rings. These three positively biased rings provide a clearing field for secondary electrons.

Each plane consists of 47 gold plated tungsten wires, spaced 0.5, 1.0 or 1.5 mm apart. The wires are 20 μ m thick and soldered on printed board. Because of the required high quality vacuum, a teflon-glass printed board instead of an epoxy one has been adopted. For the same reason, connections between the wires and the vacuum-plugs are wrapped and not soldered, the plugs are alumina or metal-glass ones, and the frame of the moni-

tor is made of stainless steel.

3. Electronics.- Two types of electronics have been developed ;
The first one (4) consists in a capacitor connected between each wire and ground to integrate the current induced by secondary electronic emission. Most of the monitors are processed by this kind of electronics.

Another type of electronics (Fig.8) are used more specifically for monitors involved in slit-method emittance measurements (5). This electronics consists of a current-voltage converter, followed by a voltage amplifier. It is very sensitive in so far as the above mentioned method uses a slit cutting the most part of the beam intensity.

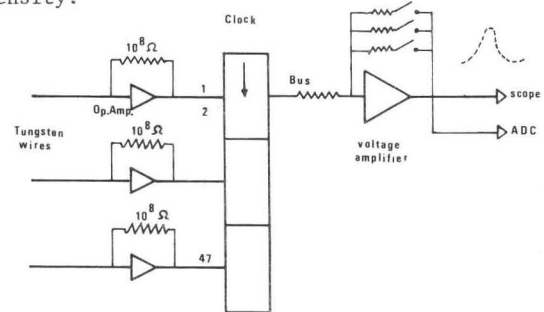

Fig. 8: Electronics.

To get the beam profiles (Fig.9), the output voltage of each of the 47 converters is scanned with a multiplexer and linked to a read-out bus. Signal is amplified and displayed on a console scope or processed by a CAMAC analog-digital converter.

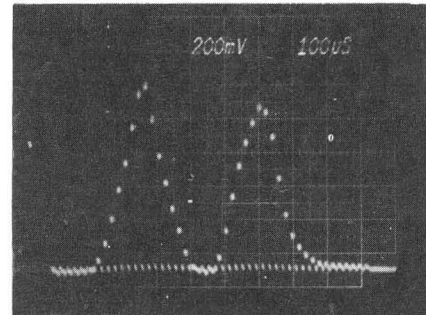

Fig. 9: Iode ion beam 8^+ $E_c = 160$ KeV

References.-

- (1) M. Promé. The GANIL control system. IEEE Trans NS 28, n° 3, June 1981.
- (2) GANIL control group. The GANIL control system as seen from the control room. This Conference.
- (3) F. Loyer, J.M. Loyant, M. Promé ; Mechanical group. Main Beam Diagnostics for the SSC. Int. Report GANIL 81R/094/CC/15, Sept. 1981.
- (4) A secondary emission multiwire chamber for GANIL heavy ion-beams tuning. R. Anne, J. Van Den Bossche, Bloomington, Sept. 18-21 1978.
- (5) B. Bru - GANIL 80N/047/TF/02. Méthodes de mesure d'émittance pour les lignes de transfert du GANIL.