



# Large scale characterisation of the concentration field of supercritical jets of hydrogen and methane

Emmanuel Ruffin, Yvon Mouilleau, Jacques Chaineaux

## ► To cite this version:

Emmanuel Ruffin, Yvon Mouilleau, Jacques Chaineaux. Large scale characterisation of the concentration field of supercritical jets of hydrogen and methane. Symposium IUTAM, Jul 1996, Marseille, France. <ineris-00971965>

**HAL Id: ineris-00971965**

**<https://hal-ineris.ccsd.cnrs.fr/ineris-00971965>**

Submitted on 3 Apr 2014

**HAL** is a multi-disciplinary open access archive for the deposit and dissemination of scientific research documents, whether they are published or not. The documents may come from teaching and research institutions in France or abroad, or from public or private research centers.

L'archive ouverte pluridisciplinaire **HAL**, est destinée au dépôt et à la diffusion de documents scientifiques de niveau recherche, publiés ou non, émanant des établissements d'enseignement et de recherche français ou étrangers, des laboratoires publics ou privés.

# Large scale characterisation of the concentration field of supercritical jets of hydrogen and methane

E. Ruffin, Y. Mouilleau, J. Chaineaux

INERIS - Institut National de l'Environnement Industriel et des Risques, Parc Technologique Alata  
BP 2 - 60550 Verneuil en Halatte France

## INTRODUCTION

When an orifice or breach appears in the wall of a tank containing flammable gas under pressure, a jet is created which develops into an explosive cloud. Research has shown that the intensity of the explosion likely to take place in this cloud is then highly variable and depends on the cloud characteristics, such as the concentration of combustible material, the velocity field and turbulence. The experimental study developed at INERIS<sup>1</sup> sought to characterise the clouds formed by supercritical jets of methane and hydrogen, and the overpressures resulting from ignition of the jets at different points. Only the work on the concentration fields will be reported here. The parameters determining the composition of the explosive cloud in the experiments carried out were: the gas used (methane or hydrogen), the vent orifice diameter (25, 50, 75, 100 or 150 mm) and the time  $t$  after the commencement of venting since the tank is of finite size and does not produce steady flow conditions. The volume of the tank (5 m<sup>3</sup>) and the pressure and temperature conditions - 40 bar and 288 K - inside it prior to the onset of venting were kept constant.

## THEORY

In the case of variable density subsonic jets, the concentration field can be described as a zone of pseudo-self-preservation. It is now clearly established that the decrease along the axis is a hyperbolic function of the distance from the orifice and that it depends strongly on the ratio ( $R_\rho$ ) of the densities of the discharged gas ( $\rho_j$ ) and the surrounding gas ( $\rho_a$ ), and the discharge diameter  $D_j$ . The equivalent discharge diameter  $D_{eq}$  allows a unique expression of the axial concentration profiles in these jets as follows:

$$\frac{C}{C_j} = \frac{1}{B} \frac{D_j}{X - X_C} R_\rho^{1/2} = \frac{1}{B} \frac{D_{eq}}{X - X_C} \quad \text{with} \quad D_{eq} = D_j R_\rho^{1/2} \quad \text{and} \quad C_j = 1 \quad (1a, b)$$

where  $X_C$  is the virtual abscissa of the hyperbolic decrease and  $X$  is the distance from the orifice (discharge section). This behavior was first noticed by Thring and Newby (1953) and later confirmed by Chen and Rodi (1980), Pitts (1991) and Djeridane (1994). In fact for a given discharge velocity, the equivalent diameter  $D_{eq}$  can be interpreted as the nozzle diameter of a jet of density  $\rho_a$  should have such that its scalar flux  $N_j = \rho_j U_j C_j D_j^2$  is the same as that of a jet of density  $\rho_j$  discharged through an orifice of diameter  $D_j$ .

<sup>1</sup> Work carried out at INERIS as part of the European EMERGE project (Extended Modelling and Experimental Research into Gas Explosions), funded jointly by the European Economic Community and the French Ministry for the Environment

In the case of supercritical jets, the discharge section (nozzle) is a sonic throat. At this point, the static pressure  $P_{noz}$  is greater than or equal to the critical pressure  $P_{crit}$  ( $P_{crit} = 2 P_{atm}$  approximately). Since the static pressure in the discharge section is thus greater than atmospheric pressure, there is a sudden expansion of the jet (expansion zone) along which the pressure in the jet returns to ambient pressure. Instead of considering the supercritical jet as from its actual discharge section, it is then possible to define fictional jet emission conditions just after the expansion zone, where the pressure in the jet is once again equal to the ambient pressure. Accordingly, Birch et al (1984) define a fictional jet, starting after the expansion zone and having new characteristics of diameter  $D_{fic}$ , velocity  $U_{fic}$  and density  $\rho_{fic}$ . Birch et al (1984) suggested the

following fictional diameter<sup>2</sup>:

$$D_{fic} = D_{noz} \sqrt{C_d \frac{P_{t0}}{P_{atm}} \left( \frac{2}{\gamma + 1} \right)^{\frac{\gamma+1}{2(\gamma-1)}} \left( \frac{T_{atm}}{T_{t0}} \right)^{1/4}} \quad (2)$$

which is obtained from considerations of mass flow conservation between the real discharge section and the fictional discharge section, putting the fictional velocity equal to the velocity of sound in the gas making up the jet at ambient conditions of pressure and temperature, and by putting the fictional density equal to the density of the gas under the same conditions. Notice that in the experiments carried out at INERIS, the control parameters  $P_{t0}$ ,  $T_{t0}$  and also  $D_{fic}$  were variable during venting of the tank due to the finite dimension of it. Since the total pressure in the tank during venting was measured in every case, we calculated the discharge coefficient defined as follows:

$$C_d = \frac{\dot{m}}{\dot{m}_{is}} = \left( \frac{V}{RT_{t0}} \frac{dP_{t0}}{dt} \right) / \left( \sqrt{\gamma P_{t0} \rho_{t0}} \cdot \pi \frac{D_{col}^2}{4} \left( \frac{\gamma + 1}{2} \right)^{\frac{\gamma+1}{2(1-\gamma)}} \right) \quad (3)$$

where  $\dot{m}_{is}$  is the isentropic mass flow and  $\dot{m}$  the real mass flow which is related to the pressure gradient measured in the tank.

## EXPERIMENTAL RIG AND OPERATING CONDITIONS

The experimental rig (figure 1) consists of a 5 m<sup>3</sup> test tank and a horizontal discharge pipe fitted with an orifice at its outer end the experimental nozzle diameter of which could be varied. Since the jets formed by the venting of this tank can extend axially for about 100 metres, the rig was placed on the edge of a low cliff so that the axis of the horizontal jets is 5 metres above the ground. With this arrangement it can be assumed that the ground has no effect on the development of the jets, at least for the first 50 metres. The concentration sensors are placed in the subsonic part of the jet, mounted on thin cables positioned perpendicularly to the flow. Each sensor (figure 2) consists of a pellistor, a metal filament heated by an electric current and coated with a catalytic material. When a mixture of air and flammable gas comes into contact with the material, oxidation takes place and the temperature of the filament rises. The voltage gradient needed to keep the filament at a constant temperature (about 873 K) can be easily related to the gas concentration in the mixture. In the measurement sensors developed and used at INERIS, the mixture passes through a sonic throat which prevents any flame from propagating to the outside of the sensor, which can then

<sup>2</sup>  $P_{t0}$  is the total pressure in the tank,  $P_{atm}$  is atmospheric pressure and  $C_d$  the discharge coefficient.

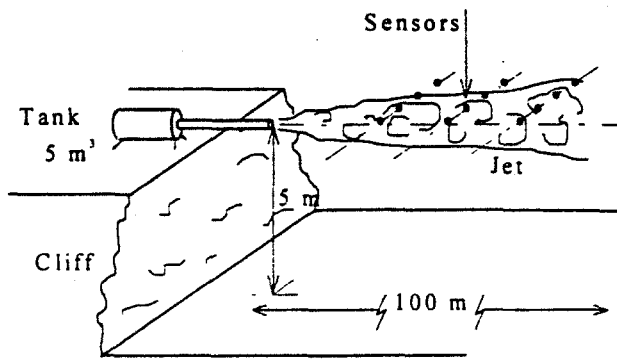

Figure 1: Experimental rig

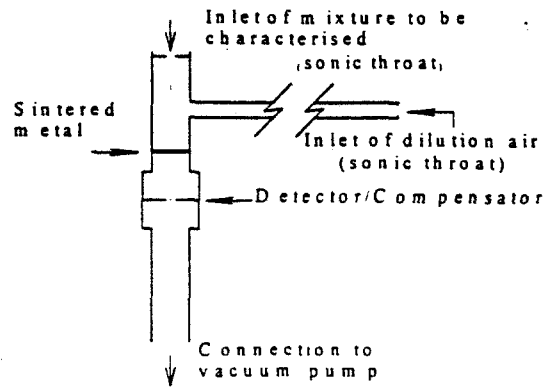

Figure 2: Diagram of a concentration sensor

be used in highly flammable environments without risk. Twelve of these sensors were built and calibrated for  $\text{CH}_4$ -air and  $\text{H}_2$ -air mixtures. Validation tests on the measurement system (monitoring concentration changes) showed that these sensors were capable of following large changes in the concentration of these gases in air, without being affected by changes in the pressure of the mixture analysed, with a short response time and with no risk of igniting the mixture.

## RESULTS

In each test<sup>3</sup>, which involved characterising the concentration field of the explosive cloud obtained by venting the pressurised tank, the gas concentration was measured at different points in the subsonic portion of the jet ( $M < 0.3$ ), along the axis and also transversely, while venting continued. The results of the measurements shows the change in the concentration of gas (methane in this case) as a function of time as the tank empties. The measurements show that the axial attenuation of the mean mass concentration is a hyperbolic function of  $X$  (its reciprocal is linear) and that it can therefore satisfy the relation given at (1).

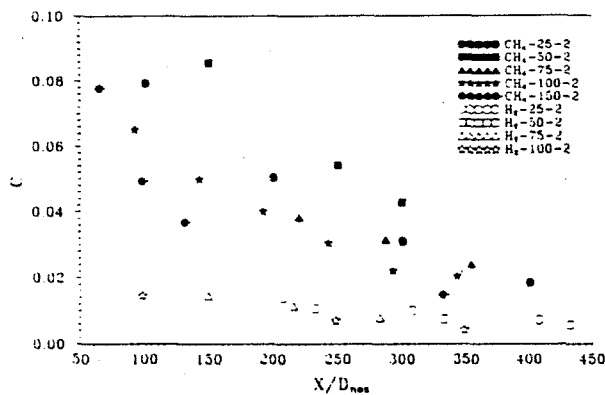

Figure 3: Axial decrease of mass concentration as a function of distance from the discharge section normalised by the relevant diameter ( $D_{noz}$ ) in supercritical jets of methane and hydrogen about two seconds after the onset of venting

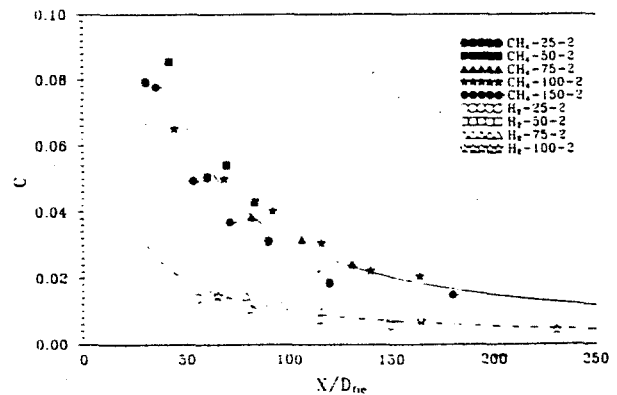

Figure 4: Axial decrease of mass concentration as a function of distance from the discharge section normalised by the fictional diameter ( $D_{fic}$ ) in supercritical jets of methane and hydrogen about two seconds after the onset of venting.

Figure 3 shows that the raw values of axial mass concentration obtained with the different jets are scattered when the concentrations are plotted as a function of distance from the nozzle normalised by the nozzle diameter. Hence this diameter is not representative of the concentration field. The results given on figure 4 show that the fictional diameter proposed by Birch et al., calculated for our

<sup>3</sup> tests were made with  $D_{noz}$  equal to 25, 50, 75, 100 and 150 mm for  $\text{CH}_4$  jets and 25, 50, 75 and 100 mm for  $\text{H}_2$  jets

experiments with the equation 3, does in fact group the methane jet data around one hyperbola and the hydrogen jet data about another. This shows that the correct allowance has been made for the effect of the pressure ratio ( $P_{10}/P_{atm}$ ) and that the assumption of successive steady states which allows us the calculation of  $\dot{m}$  is quite good.

Moreover, if allowance is made for the ratio between the fictional densities and the density of the ambient fluid, then all the results lie along a single curve for which the decay rate  $B$  is around 0.27. These results for supercritical unsteady jets of methane and hydrogen confirm those found by Birch et al for supercritical steady jets of natural gas and ethylene. They are also a good validation

of the original measurement technique developed by INERIS and used in an industrial-type situation, i.e., on a very large scale. Finally, figure 5 shows that the decay rates found in the supercritical jets and in the variable density

subsonic jets are entirely comparable. In fact, one can show that the mass flow conservation hypothesis used by Birch et al. to obtain the fictional diameter verifies also the hypothesis which leads to the law of pseudo-self similarity in variable density subsonic jets, i.e. the conservation of the scalar flux at the exit of the jet. Consequently the fact that a common decay rate is found for the decrease of the scalar in supercritical jets and in variable density subsonic jets merely expresses the validity of one and the same conservation law which is that of the flux of the scalar quantity.

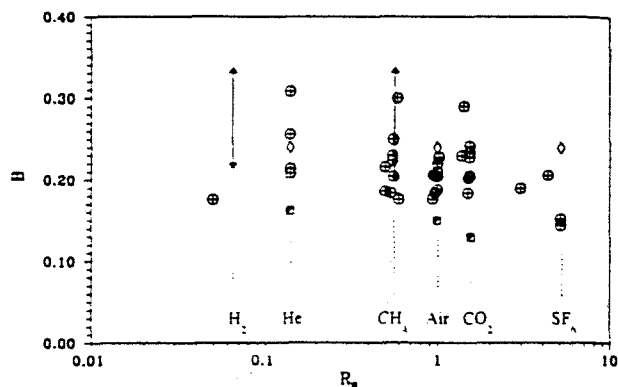

Figure 5: 'Universal' decay rate of mass concentration along the axis of subsonic jets  $[B = (C_j/C) D_j/(X-X_c)(\rho_j/\rho_a)^{1/2}]$  and supercritical jets  $[B = (C_j/C) D_{fic}/(X-X_c)(\rho_{fic}/\rho_a)^{1/2}]$ . Results for supercritical jets:  $\leftarrow$  present results: \*, experiment of Birch et al (1984). Results for subsonic jets:  $\oplus$ , compilation of experiments by Fulachier et al (1990);  $\boxtimes$ , IMST experiment (Djeridane 1994);  $\diamond$ , calculations using a second order turbulence model (Ruffin 1994).

## CONCLUSION

First of all, the large scale experimental tests carried out at INERIS confirm the results obtained by Birch et al in a laboratory. In this way it was possible to validate, in an industrial-type situation and using highly reactive mixtures, an original system with short response time for measuring concentrations of flammable gases.

Secondly, it is by no means certain that the fictional diameter proposed by Birch et al is representative of changes in quantities other than the mass concentration.

## REFERENCES

CHEN C.J. & RODI W. (1980). The science & appl. of heat and mass transfer. Pergamon Press.  
 BIRCH A.D., BROWN D.R., DODSON M.G., SWAFFIELD F. (1984). Comb. Sci. and Tech., vol. 36, pp. 249-261.  
 DJERIDANE T. (1994). PhD Th., Univ. AixMarseille II.  
 FULACHIER L., ANSELMET F., AMIELH M. (1990). 27ème Colloque d'Aérodynamique Appliquée, Marseille.

PITTS W.M. (1991). Exp. Fluids, vol. 11, pp. 125-134  
 RUFFIN E., SCHIESTEL R., ANSELMET F., AMIELH M. & FULACHIER L. (1994). Phys. Fluids A, vol. 8, n°6, pp. 2785-2799.  
 RUFFIN E. (1994). PhD Thesis. Univ. AixMarseille II.  
 THRING M.W. & NEWBY N.P. (1953). 4th Int. Symp. Comb., Pittsburgh.