



Roof characterisation related to fire propagation risk by a numerical approach

Luc Fournier, André Carrau, P. Russo

► To cite this version:

Luc Fournier, André Carrau, P. Russo. Roof characterisation related to fire propagation risk by a numerical approach. Fire and Materials Conference, Jan 2003, San Francisco, United States. pp.389-398, 2003. <ineris-00976146>

HAL Id: ineris-00976146

<https://hal-ineris.ccsd.cnrs.fr/ineris-00976146>

Submitted on 9 Apr 2014

HAL is a multi-disciplinary open access archive for the deposit and dissemination of scientific research documents, whether they are published or not. The documents may come from teaching and research institutions in France or abroad, or from public or private research centers.

L'archive ouverte pluridisciplinaire **HAL**, est destinée au dépôt et à la diffusion de documents scientifiques de niveau recherche, publiés ou non, émanant des établissements d'enseignement et de recherche français ou étrangers, des laboratoires publics ou privés.

ROOF CHARACTERISATION RELATED TO FIRE PROPAGATION RISK BY A NUMERICAL APPROACH

L. Fournier¹, A. Carrau¹ and P. Russo²

1. INERIS, Verneuil-en-Halatte, France
2. LCD, C.N.R.S. UPR 9028 -E.N.S.M.A.,
Université de Poitiers, Futuroscope, France

1 ABSTRACT

The experience shows that roofing systems are to be considered as a major factor of the fire propagation in industrial buildings like warehouses.

Currently in France, regulations require that two main measures be implemented to limit the propagation of the fire by the roof:

- one is the use of intumescent strips on the roof,
- the other consists of extending the fire walls (typically 70 cm or 1 m) above the roof level in order to prevent the flame from being blown down onto roof top.

A set of normalised-like live tests is used to study the behaviour of roofing systems submitted to interior or exterior fire. Unfortunately, the aforementioned measures are not easily modelled through live tests, and this prompted the need to develop an accurate computer modelling method.

Therefore, this paper presents a computer modelling approach aiming at studying the influence of such intumescent strips or wall upstands on the heat propagation properties of current roofing materials. In this paper, two kinds of roofing systems are studied:

- one containing stone wool as insulating material,
- the other containing polyurethane as insulating material.

The numerical code used is Fire Dynamic Simulator^{1,2} (FDS), developed by the NIST, with a special additional heat conduction module.

2 INTRODUCTION

During fires, the structure stability and the fire propagation behaviour are major information for safety services. The framework of industrial fire is currently being given a special attention in European countries regulation. The conception of industrial premises like for example warehouses that requires a set of tests and specifications are considered adequately. The underlying technical constraints are more or less specific to each country, but are usually based on "large scale" tests.

The present work points out the roofing system characterisation in the case of external fires. It focuses on the determination of the roof behaviour of a building adjacent to a large fire. The roof is in that case only exposed to the fire heat flux. This kind of characterisation is usually done by standardised life tests of the roofing system composite material. These tests are developed for usual size of fires. In the case of an actual industrial accident, the size and the power of fires are not of the same order of magnitude. Consequently, in the one hand, standardised life tests cannot be satisfying for such a configuration. In the other hand, these tests cannot realistically be extended to representative real size buildings. Computational simulation can be an adequate way to treat these real scale problems.

The aim of this paper is to present a numerical way of work and some preliminary elements. The paper comprises two main parts. The one is dedicated to a short presentation of standardised European life tests, and several points of the French regulation in the field of industrial buildings. The second one is dedicated to the numerical approach presentation and more precisely to the models used and some

preliminary results.

3 PROBLEMATIC OF WAREHOUSE ROOF

In the European market, there is a lot of different kind of roofs. Generally, a warehouse roof is composed by a support, an insulating material and a covering material. The combination of these three components gives more than one hundred possibilities to construct a roof.

In France³, roofs with a slight slope (less than 5%) are very popular for industrial buildings. Approximately, 80% of the warehouses are constructed with a steel support. Because of a restrictive regulation, the insulating material is mainly mineral wool (92%).

3.1 Large-scale fire tests for the assessment of an external fire exposure to roofs

The aggression of the roof by an external fire concerns first the covering membrane and then the insulating material. It can be due to a drop of a burning brand, to a flame or to a radiant heat impact. All three factors may be modified by meteorological conditions like the wind. If the covering material is ignited, two problems have to be analysed: the fire propagation on the roof surface and the in depth penetration of the fire and potential propagation through the roof on the internal side of the building. In Europe, different countries have developed large-scale fire tests to study these problems. The European commission is currently trying to harmonise them with no success at the time. A draft standard pr EN 1187³, under discussion, is divided into three sections:

- pr EN 1187.1: the methodology is similar to a German standard (DIN 4102.7) and a Dutch standard (NEN 6063).

The method, basically, consists to expose a model of system (0.8 mx1.8 m) to a burning crib composed by a support in steel or wood, an insulating material and a covering membrane set up with a slope of 15°.

1. pr EN 1187.1 live test configuration

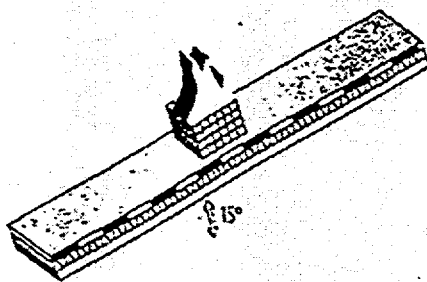

- pr EN 1187.2: the methodology is similar to the standard NT Fire 006 which is used in the Scandinavian countries.

The model system (0.4 mx1 m) is composed more simply by an insulating material with a covering membrane set up with a 30° slope. This system is submitted to a crib fire with an external wind of 2-4 m/s and an aspiration of 6 m/s.

2. pr EN 1187.2 live test configuration

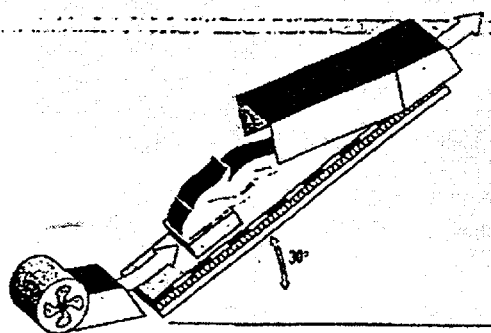

- pr EN 1187.3: the methodology is similar to a French specification. In this case, the system (1.2 mx3 m) is composed of a steel frame supporting an insulating material and topped by a covering membrane. The set up slope there varies between 3 to 15°. The system is submitted to a calibrated fire source with a wind of 10 km/h and an additional radiant heat flux of 12,5 kW/m².

3. pr EN 1187.3 live test configuration

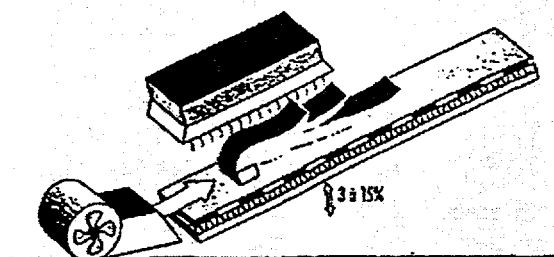

To classify a roof, in France, two performance criteria are defined:

- The time rating “T” for the fire to penetrate through the roof;
- The propagation of the fire on the surface considering the time t_1 corresponding to the ignition of the roof and the time t_2 corresponding to the time when the fire has reached the top of the roof.

The roof is thus classified with:

- A fire resistant class relying on the T rating value. Three classes are defined :
 - Class T30 if $T > 30$ mn,
 - Class T15 if $T > 15$ mn,
 - Class T5 if $5 < T < 15$ mn,
- A fire propagation index qualifying the fire propagation propensity on the surface based on $(t_2 - t_1)$:
 - Index 1 : if $(t_2 - t_1) > 30$ mn,
 - Index 2 : if $10 \text{ mn} < (t_2 - t_1) < 30$ mn,
 - Index 3 : if $(t_2 - t_1) < 10$ mn.

Also, in France, a roof can be classified according to nine different FR classes: T30/1, T30/2, T30/3, T15/1, T15/2, T15/3, T5/1, T5/2, T5/3.

The difficulty to harmonise such a large-scale tests can be explained by the diversity of the roofing in the systems existing in the different European countries.

These different large-scale tests allow comparing the fire behaviour of the different roofs but

they are not necessary representatives of a real industrial fire such as warehouse fire. Indeed, the analysis of different warehouse accidents shows that the actual fire propagation by the roof can be significantly faster than the propagation observed in a large-scale test.

In addition, a modelling approach could be an interesting alternative to try to characterise the roof behaviour with an industrial fire.

3.2 The French regulation requirement

In France, a new regulation concerning the warehouses was published on the 1st January of 2003. In particular, this regulation enforces rules to limit the fire propagation by the roof. For instance, the roof has to fulfil the following characteristics:

- the roof support has to be realised with materials of combustibility class M0,
- the insulating material, if any, shall be made of materials of combustibility class M0 or materials of combustibility class M1 with a gross heating value lower than 8,4 MJ/kg,
- the global roof FR rating is at least T30/1 (see previous paragraph).

Another point to limit the fire propagation concerns the use of fire wall barriers between two cells of the warehouse. This wall is defined as follow:

- the wall has to stop and resist to a fire during at least 2 hours,
- the wall overtops the roof of 1 meter. The roof has to be covered by an incombustible layer of 5 meters wide on both side of the fire wall.

4 NUMERICAL SIMULATION APPROACH

4.1 Physical and numerical model

The simulation of a real industrial fire is a difficult scientific and technical work. It involves complex phenomena (combustion, heat transfer, turbulent flow...) with complex geometries (large building clutter up numerous small objects). The study of the roofing system stability during an external fire needs to represent realistically the incident heat flux and the coupling between the heat transfer in the roof and its surrounding. This requires a good modelling of:

- the fluid flow,
- the adjacent fire,
- the heat transfers in the fluid,
- the heat transfer in composite solids (the roof).

The present chapter aims at described the key point chosen for this modelling based on the use of the computational fluid dynamics code named FDS^{1,2} from NIST.

4.1.1 The fluid flow modelling

The fluid flow is modelled by the numerical resolution of conservation equations (Navier Stokes equations) for total mass, momentum, energy, and species mass fractions (fuel and oxygen), formulated as,

$$\frac{\partial \rho}{\partial t} + \frac{\partial \rho u_j}{\partial x_j} = 0 \quad [1]$$

$$\frac{\partial \rho u_i}{\partial t} + \frac{\partial(\rho u_i u_j)}{\partial x_j} + \frac{\partial p}{\partial x_i} - \rho g_i = \nabla \tau_{ij,SGS} \quad [2]$$

$$\frac{\partial \rho h}{\partial t} + \frac{\partial(\rho u_i h)}{\partial x_j} - \frac{Dp}{Dt} = \frac{\partial}{\partial x_j} \left(\frac{\mu_t}{Pr_t} \frac{\partial h}{\partial x_j} \right) + \dot{q}_c + \dot{q}_r \quad [3]$$

Here, u is the velocity, p the perturbation pressure from ambient, ρ the density, g the acceleration of gravity, τ_{ij} the standard viscosity stress tensor, \dot{q}_c the heat release rate per unit volume, \dot{q}_r the radiant energy flux, and Pr_t ($=0.5$) the turbulent Prandtl number.

As large fires take place in turbulent flow, a Large Eddy Simulation (LES) approach is used with implementation of the Smagorinsky sub-scale model² which introduces the sub-grid scale (SGS) Reynolds stresses, $\bar{\tau}_{ij,SGS}$, associated with the local large scale rate of strain. To compute the pressure, an ideal gas is considered by the use of its equation of state.

4.1.2 Fire modelling

The global one-step irreversible chemical reaction for full combustion of a hydrocarbon fuel is assumed,

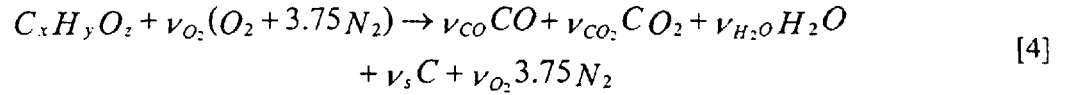

where ν_i is the stoichiometric coefficient of the substance i . Combustion process is assumed to be diffusion controlled, permitting a mixture-fraction-based modelling approach,

$$\frac{\partial \rho f}{\partial t} + \frac{\partial(\rho u_j f)}{\partial x_j} = \frac{\partial}{\partial x_j} \left(\frac{\mu_t}{Sc_t} \frac{\partial f}{\partial x_j} \right) \quad [5]$$

where Sc_t ($=0.5$) denotes the turbulent Schmidt number and f is the mixture fraction.

4.1.3 Modelling of heat transfer in the fluid

A fraction of the energy released by the combustion is scattered by radiation and the rest by directly transfer to the fluid. This fraction is arbitrarily taken at 35%. This value is known to decrease while the fire size increases and can have values varying for 50% to 5%.

The heat release rate is directly proportional to the rate of oxygen consumption as illustrated by the next equation:

$$\dot{q}_c = -\Delta H_o \dot{m}_o''' \quad [6]$$

Here, ΔH_o is the heat release rate per unit mass of oxygen consumed and \dot{m}_o''' is the mass of oxygen consumed by unit time and volume which is calculated from the local mixture fraction [5] and a state relation.

The radiant flux vector in the energy equation [3] is calculated by integrating the radiation intensity over

all directions. The radiation intensity is found by solving the following radiant transfer equation without scattering,

$$\bar{\nabla} \cdot \bar{\Omega} I + \kappa I = \kappa \frac{\sigma T^4}{\pi} \quad [7]$$

where κ is the absorption coefficient, I the radiation intensity and σ the Stefan-Boltzmann constant. The absorption coefficient, κ , is a function of the mixture fraction and independent of the wavelength.

4.1.4 Conduction of heat in the roof

FDS provides a 1D homogeneous semi-infinite conduction model. Consequently, a new conduction model has been implemented in the FDS code to serve the purpose of this study. The heat conduction in the roof is modelled by use of the Fourier equation for an heterogeneous 3 dimensional material:

$$\text{div}(k \cdot \text{grad} T) + \dot{q} = \rho c \frac{\partial T}{\partial t} \quad [8]$$

where ρ denotes the solid density, T its temperature, k its thermal conductivity, c its specific heat and finally \dot{q} represents a volumic heat source.

This equation is discretised using a finite volume method for the 3 spatial dimensions, and a fully implicit scheme for the time dependency. This kind of approach is a usual technique described by Patankar⁴. Validation has been performed by comparison with Holman⁵'s examples.

The coupling between the fluid flow, the radiation heat transfer and the solid heat transfer is proposed in the FDS technical documentation² and leads to use the following equation:

$$-k \frac{\partial T}{\partial n}(0,t) = \dot{q}_c + \dot{q}_r - 4 \varepsilon \sigma \left(T_w^{(n)4} - T_w^{(n+1)4} \right) \quad [9]$$

where $T_w^{(n)4}$ and $T_w^{(n+1)4}$ respectively denotes the wall temperature at time step n and $n+1$.

Consequently, the boundary condition for conduction is a linear function in temperature and heat. The coherency of results with FDS own conduction module has been checked.

4.2 Computation hypothesis

4.2.1 General description

The simulated scenario is a large open fire bordering a warehouse. The side of the warehouse is made of incombustible brick wall. The resistance of this wall is not in the scope of the study. It is consequently considered adiabatic.

The wall is 6m high and 0.2m depth. The roof composed of Sandwich panels is placed horizontally on the save side of the wall at 0.7m meter from its top. The related case study background is synthesised in the following figure:

4. General configuration

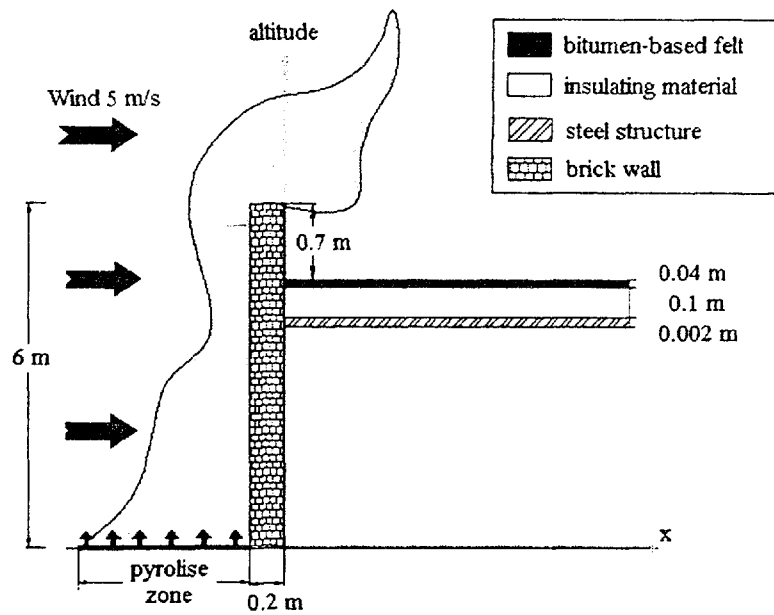

4.2.2 Sandwich panel representation

The next figure represents the composite structure of the considered sandwich panel. The steel bottom provides the mechanical stability. The outside protection of the insulating layer is fulfilled by the bituminous felt.

5. Composition of sandwich panel

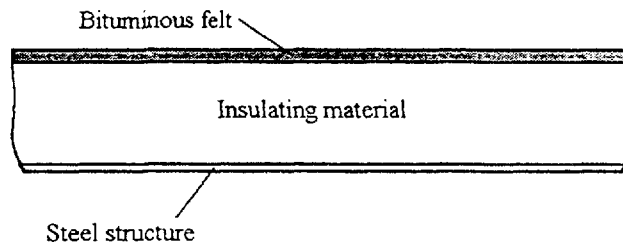

The insulating materials treated in this study are polyurethane foam and stone wool.

6. Thermophysical data used for roofing components

	Density (kg.m^{-3})	Conductivity ($\text{W.m}^{-1}.\text{K}^{-1}$)	Specific heat ($\text{J.kg}^{-1}.\text{K}^{-1}$)
polyurethane foam	60	0.02	1900
stone wool	200	0.04	670
Bitumen-based felt	2120	0.7	2000
Steel structure	7750	36	486

The shape of the steel structure is represented for the conduction computation. The mesh used to solve conduction has 20 nodes across the panel and a corresponding mesh with the fluid flow problem on the surface side.

4.3 First numerical results

The first modelling trials have been made considering only heat conduction in roof. The pyrolysis phenomenon is not yet considered.

Two computations have been done: one for each insulating material. Figures 7 and 8 show a cross view plan of the roof. The altitude (depth in material) and the distance to the wall and the fire are used to define the related plan view. Readers should take care of the scale that is not same in both directions.

Taking into account only the heat conduction process, a slower thermal wave in the roof is observed for the Polyurethane foam because of its better insulating properties. Moreover, the steel structure reaches only 310K in temperature and keeps its mechanical stability in case of stone wool insulation after an exposure of 2 hours. Nevertheless, this conclusion will be different by considering a secondary fire due to ignition of the covering material.

7. Stone wool insulated roof at 0.7m from the top of the wall

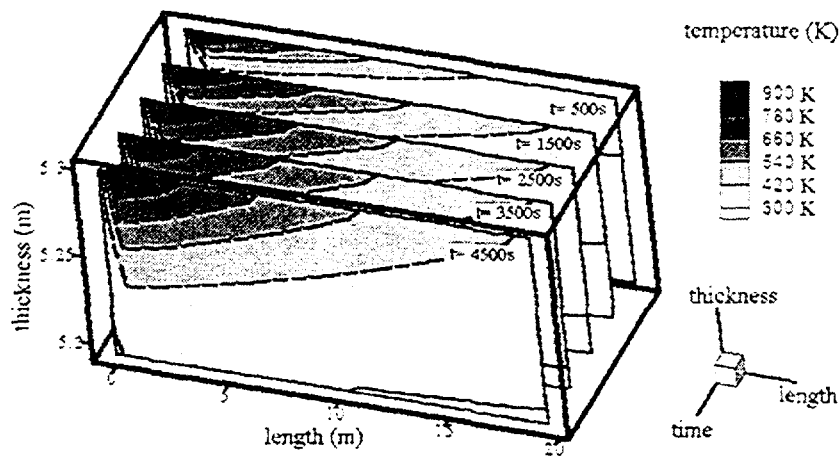

8. Polyurethane foam insulated roof at 0.7m from the top of the wall

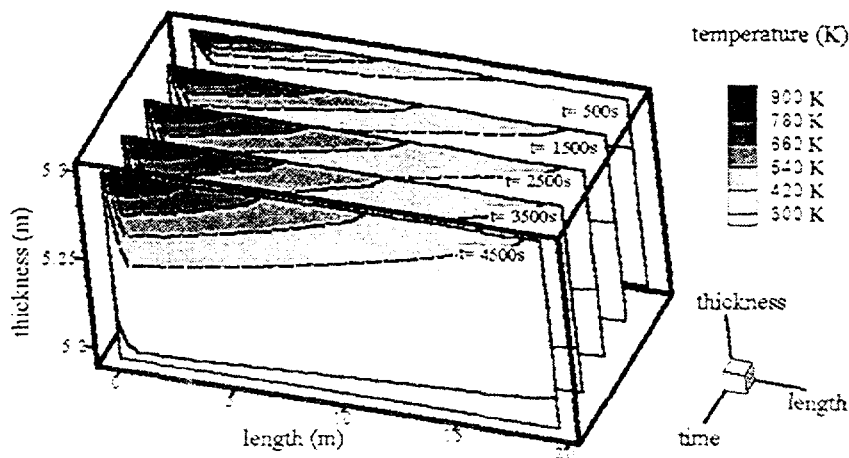

It should be noticed that the ignition temperature of bitumen is around 300°C and its self-inflammation temperature around 500°C. Figure 9 shows that a bitumen zone has reached its ignition temperature after only 2 minutes. The self-inflammation temperature is locally reached after 5 minutes. These two observations mean that a fire at the roof surface will likely start no more than 5 minutes after the main fire. Also, the propagation of the fire to the rest of the roof cannot be modelled only by considering the radiation impact of the main fire and the heat conduction inside the roof.

9. Time evolution of roof surface temperature (stone wool insulating material)

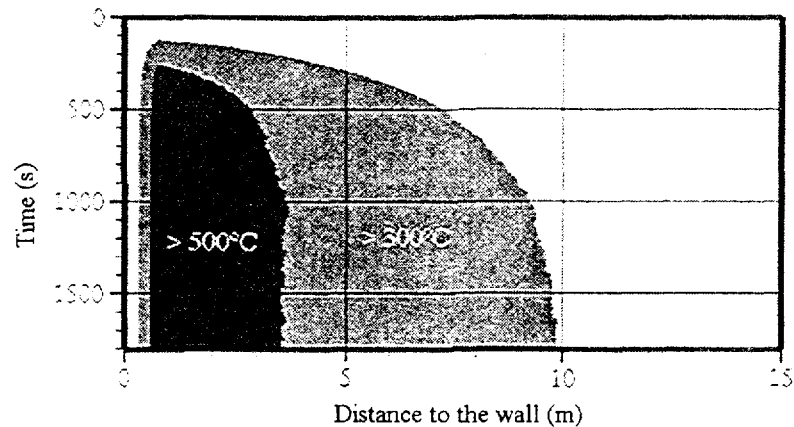

It appears from the computation, that the formation of these zones is not significantly dependent on the insulating material.

The ignition of the covering membrane at the roof surface would significantly change the level of heat received by the roof. The radiant heat emitted by the main fire might be partially absorbed by the secondary fire smoke plume. By contrast, the radiant heat produced by the secondary fire would be added to the previous one. In addition to those considerations, the secondary fire would drive the convection motion patterns in the surroundings. The heat exchange with the roof surface would be completely modified. The production of bitumen puddle and its vaporisation would result in a loss of energy received by the solid. One other important phenomenon is the material ablation due to combustion reaction.

At this stage, we can guess that the propagation is fairly different between roofing systems according to the type of insulating material in consideration as far as the secondary fire actually reaches the insulating material itself.

These more detailed considerations can be partially looked at by use of the current code (FDS + 3D conduction module). The main difficulties result in the energetic distribution between the three phases of the combustible (solid, liquid and gas) and the rate of fuel production. These aspects are essential to evaluate the fire properties and the ablation phenomena. It will be the future way of investigation to get a realistic and usable model.

5 CONCLUSION

Fire propagation by the roof is an important phenomenon in industrial accidents such as warehouse fires. The hazard prevention regulations in Europe impose a set of specifications for such roofing system. These specifications are based on roofing system characterisation by the use of large-scale live tests. However, these tests are not necessarily representative of industrial size buildings and of industrial fires and still suffer today from lack of harmonisation.

The numerical modelling can be an alternative approach to the standardised live tests. It aims at considering the real dimensions as well as the actual characteristics of large industrial fires. The original CFD code named FDS is specially designed for such kind of fire, but has not reached a status of development allowing detailed interaction phenomena between fire and materials. Consequently, a new 3D-conduction model has been implemented to evaluate heat conduction inside the roof. This paper presents preliminary results where only heat transfer by conduction has been considered. These results show that the roof surface, composed of bitumen, will start to burn rapidly in the event of our test case study (a major fire adjacent to the piece of roofing material under consideration). Also, the future developments of this work will be focusing on the implementation of other physical models such as liquefaction and vaporisation models suitable for bitumen and insulating materials and a fire ablation model.

6 REFERENCES

- ¹ K. B. Mc Grattan, G. P. Forney, J. E. Floyd and S. Hostikka, Fire Dynamics Simulator (version 2) – User’s guide, National Institute of Standards and Technology, NISTIR 6784, November 2001.
- ² K. B. Mc Grattan, H. R. Baum, R. G. Rehm, A. Hemins, G. P. Forney, J. E. Floyd and S. Hostikka, Fire Dynamics Simulator (version 2) – Technical reference guide, National Institute of Standards and Technology, NISTIR 6783, November 2001.
- ³ C. Cwiklinski, “Comportement au feu des toitures- Synthèse bibliographique”, www.ineris.fr
- ⁴ S. V. Patankar, Numerical Heat Transfer and Fluid Flow, series in computational methods in mechanics and thermal sciences, McGraw-Hill, ISBN 0-07-048740-5, 1980.
- ⁵ J. P. Holman, Heat Transfer, 8th edition, McGraw-Hill, ISBN 0-07-114320-3, 1997.