

## STATUS OF THE SC CW-LINAC DEMONSTRATOR

V. Gettmann, M. Amberg, S. Jacke, HIM, Mainz, Germany  
 W. Barth, S. Mickat, GSI, Darmstadt, HIM, Mainz, Germany  
 K. Aulenbacher, HIM, Mainz, IKP, Mainz, Germany  
 A. Orzhekhovskaya, GSI, Darmstadt, Germany  
 U. Ratzinger, H. Podlech, F. Dziuba, IAP, Frankfurt am Main, Germany

### Abstract

The kick-off for the cw Linac Demonstrator project at GSI was in 2010 with the aim of a “full performance test” of a 217 MHz sc CH-Cavity at the GSI-High Charge Injector (HLI). Meanwhile the design of the key components is finalized and their fabrication has started. In addition the test environment at GSI HLI is about to be completed, so that the commissioning of the sc cw Linac Demonstrator is planned in 2014, when the key components are expected to be delivered. In the following the project status is reported.

### CW LINAC DEMONSTRATOR

Table 1: Main Parameters

CH-Cavity		
$\beta$		0.059
max A/Q		6
Frequency	MHz	217
Gap number		15
Total length	mm	690
Cavity Diameter	mm	409
Aperture	mm	20
Effective gap voltage	kV	225
Accelerating gradient	MV/m	5.1
Cryostat		
Inside length	mm	2200
Inside diameter	mm	1120
Material		Al
Operating temperature	K	4.4
Operating pressure above atmosphere	bar	< 1
Solenoids		
Bore	mm	30
Overall length	mm	380
Max. field	T	9.3
Nominal current	A	110
Homogeneity		0.001

The Demonstrator project kick-off at GSI was in 2010, which was followed by design studies for the key components like the 217 MHz CH cavity, two sc solenoids, and the cryostat itself. Meanwhile the design of the components is finalized and their fabrication has started. The main parameters are listed in table 1.

The concept of a suspended support frame, which carries the cavity embedded by two sc solenoids, is followed [1]. The support frame as well the accelerator components are suspended each by eight tie rods in a cross-like configuration (nuclotron suspension) balancing the mechanical stress during the cooling-down and warm up (Fig.1). This way the components will always stay within the tolerance limits related to the beam axis (long.  $\pm 2\text{mm}$ , trans.  $\pm 0.2\text{mm}$ ).

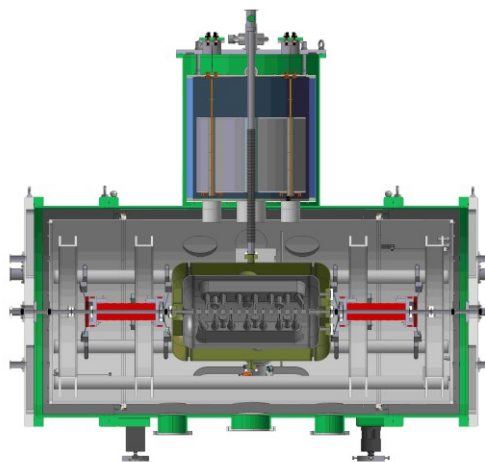

Figure 1: The cw Demonstrator comprising a CH-cavity embedded by two solenoids on a support frame, which is hung into the cryostat.

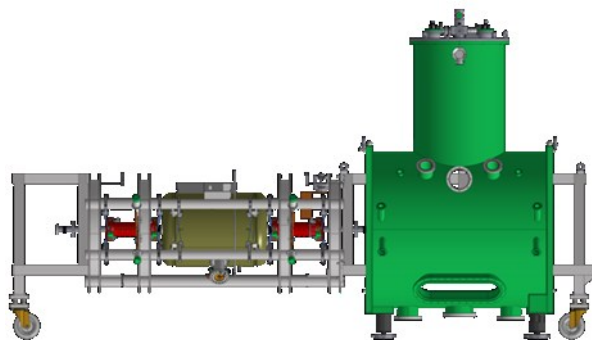

Figure 2: Loading/unloading the cryostat scheme.

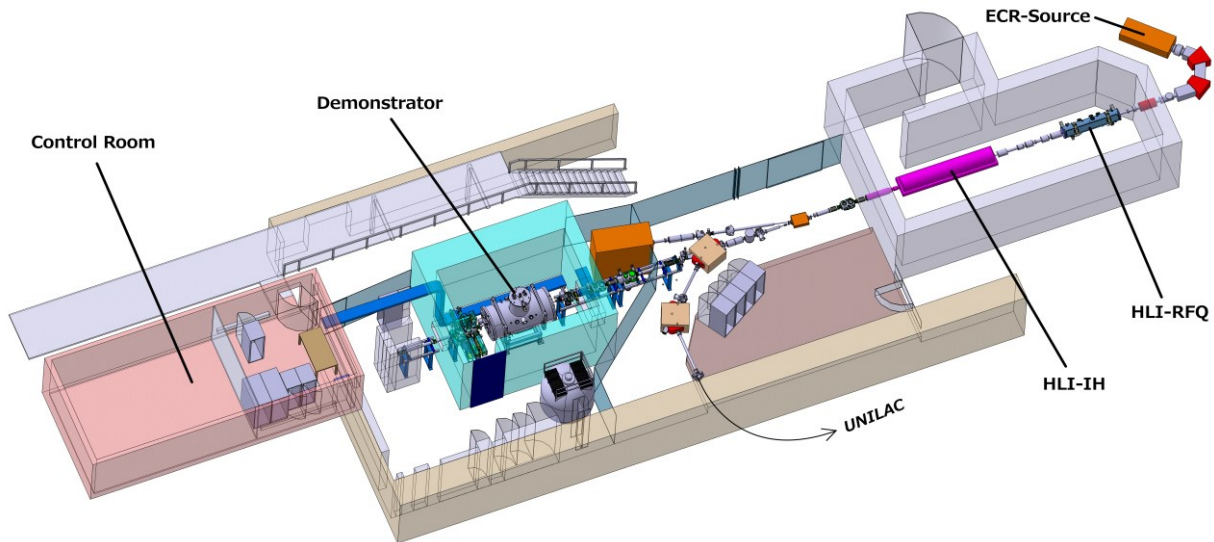

Figure 3: The layout of the GSI accelerator facility with the cw-LINAC Demonstrator integrated in the existing HLI.

Together with Cryogenic Limited (UK), the provider of the cryostat and the solenoids, the design was optimized with respect to assembling and maintenance. The cryostat's outer tank is three divided and allows a convenient loading and unloading (Fig.2).

Another mentionable feature concerns the two sc solenoids. A configuration of one main coil out of NbSn and two compensation coils made from NbTi shields the maximum magnetic field of 9.3 T within 10 cm to acceptable 30 mT at the position of the neighbored cavity. The solenoids are connected to LHe pots inside the cryostat by copper tapes allowing dry cooling.

The CH cavity is cooled with LHe directly using a He jacket out of titanium. The manufacturer is Research Instruments (GER). The delivery is expected at the end of 2013 [2].

### SETUP AT GSI HLI

Commissioning of the Demonstrator is planned in 2014 at the GSI HLI, which operates at 108 MHz (Fig.3). A new beam line in straightforward direction to the HLI, which transports the beam to the new radiation protection shelter locating the Demonstrator, was designed regarding beam dynamical simulations. It is shown that for transverse matching one additional quadrupole doublet in front of the Demonstrator is needed (Fig.4).

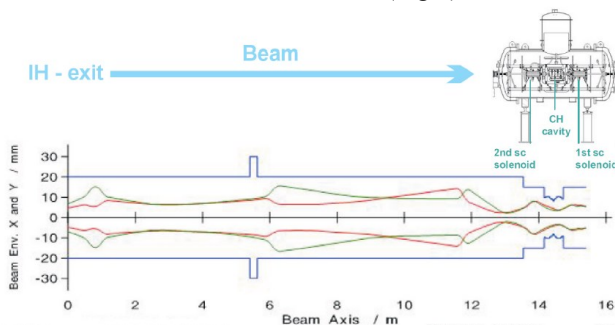

Figure 4: Transverse envelope from the HLI IH exit to the Demonstrator.

For adequate longitudinal matching the existing HLI buncher must be combined with a second 108 MHz buncher (Fig. 5).

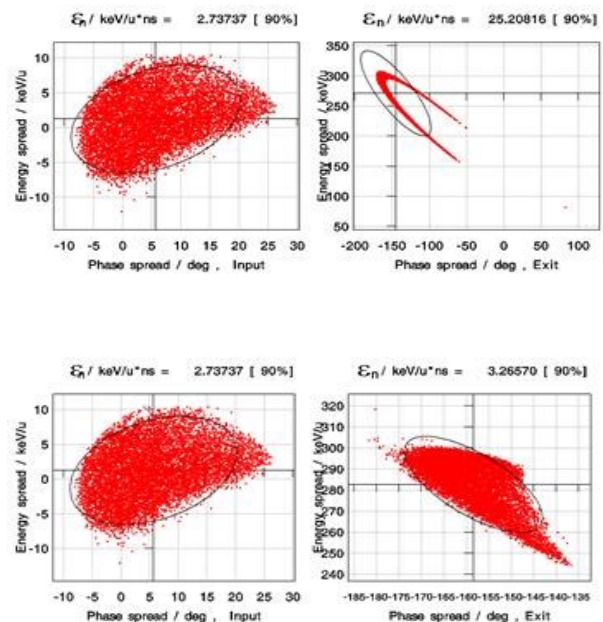

Figure 5: Longitudinal emittance at HLI IH exit (input) and calculated emittance in front of the Demonstrator directly (output) using the existing HLI buncher only (top) and in combination with a second buncher (bottom).

The new beam line with focusing and steering magnets has been installed already as well as beam diagnostic components in front of and behind the Demonstrator (Fig.6). The beam line is equipped with profile grids, beam transformers and an emittance measurement station. Phase probes are used for output energy measurements applying the time of flight (TOF) method.



Figure 6: Radiation protection shelter in front of the HLI shelter in December 2012.

## TIMETABLE

Table 2: Timeline

<b>cw-LINAC – Demonstrator-Project</b>	
2010	Kick-off at GSI Tendering of demonstrator components
2011	Delivery of LHe-supply and rf-amplifier Ordering of cavity, solenoids, cryostat Assembly of test area @GSI started
2013	Delivery of cavity 1st tests (warm + cold) at IAP
2014	Delivery of solenoid and cryostat
2014/15	Full performance test at GSI HLI

## OUTLOOK & FUTURE APPLICATIONS

The Demonstrator project is a proof of principle on the CH cavity. Successful full performance tests with beam of the sc CH-cavity open a broad field of accelerator applications, e.g.:

- The first 360 MHz prototype was developed within EUROTRANS (European research program for the transmutation of high level nuclear waste in an accelerator driven system). The follow-up project, MYRRHA, is planned to be commissioned in

2023. Four 176 MHz sc CH cavities are integrated into the accelerator driven system (ADS) [3].

- Another future application is the sc cw-LINAC at GSI [4]. Especially the Super Heavy Elements (SHE) program at GSI and at the Helmholtz Institute Mainz (HIM) benefits highly from such a dedicated accelerator. As a next step the extension of the Demonstrator to a string of five 217 MHz CH-cavities is proposed (advanced Demonstrator) (Fig.7) [5].

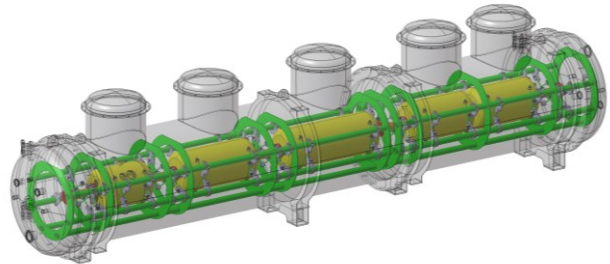

Figure 7: Draft version of a multi cavity advanced demonstrator layout.

## REFERENCES

- [1] V. Gettmann et al., THE SC CW-LINAC DEMONSTRATOR – FIRST SECTION OF A SC CW-LINAC, Proceedings of SRF2011, Chicago, USA (2011).
- [2] Dziuba et al. A Superconducting 217 MHz CH Cavity for the CW Demonstrator at GSI, these proceedings THP006, Paris, France (2013).
- [3] D. Mäder et al., Consolidated Design of the 17 MeV Injector for MYRRHA, these proceedings MOP065, Paris, France (2013).
- [4] S. Mickat et al., The status of the cw -LINAC at GSI, Proceedings of Exon2012, Vladivostok, Russia (2012)
- [5] W. Barth et al., ADVANCED SUPER-CONDUCTING CW HEAVY ION LINAC R&D, Proceedings of IPAC2013 THPWO007, Shanghai, China (2013).