

STRIPPING OF HIGH INTENSITY HEAVY-ION BEAMS IN A PULSED GAS STRIPPER DEVICE AT 1.4 MeV/u

P. Scharrer^{1,2,3}, W. Barth^{1,2}, M. Bevcic², Ch. E. Düllmann^{1,2,3}, L. Groening², K. P. Horn², E. Jäger², J. Khuyagbaatar^{1,2}, J. Krier², A. Yakushev²

¹Helmholtz Institute Mainz, Mainz, Germany

²GSI Helmholtzzentrum für Schwerionenforschung, Darmstadt, Germany

³Johannes Gutenberg-University, Mainz, Germany

Abstract

As part of an injector system for FAIR, the GSI UNILAC has to meet high demands in terms of beam brilliance at a low duty factor. To accomplish this goal an extensive upgrade program has started.

To increase the beam intensity behind the UNILAC, it is aimed to increase the efficiency of the 1.4 MeV/u gas stripper. A modification of the stripper setup was developed to replace the N₂-jet with a pulsed gas injection, synchronized with the transit of the beam pulse. The pulsed gas injection lowers the gas load for the differential pumping system, rendering possible the use of other promising gas targets.

In recent measurements the performance of the modified setup was tested using an ²³⁸U-beam with various stripper media, including H₂, He, and N₂. The data provide a systematic basis for an improved understanding of slow heavy ions passing through gaseous media. The stripping performance of the current N₂-jet was excelled by using H₂ at increased gas densities, enabled by the new pulsed gas cell.

INTRODUCTION

The GSI UNiversal LInear ACcelerator (UNILAC) will serve as part of an injector system for the future Facility for Antiproton and Ion Research (FAIR), currently under construction at GSI in Darmstadt, Germany. Therefore it has to meet high demands in terms of beam brilliance at a very low duty cycle (100 μs beam pulse length, 2.7 Hz repetition rate) [1]. To achieve this goal, an extensive upgrade program of the UNILAC has been started [2].

After acceleration in the UNILAC High Current Injector the ion beams are passing a gas stripper section at 1.4 MeV/u. The ions are stripped of electrons and the charge state of the ion beam is increased. After stripping, a charge state distribution results, and charge separation is accomplished by a system of dipole magnets; thus, only ions with the desired charge state are selected for further acceleration. The current gas stripper uses a laval nozzle at a back-pressure of 0.4 MPa to apply a super-sonic N₂-jet [3].

A key projectile for FAIR is ²³⁸U [1]. In the gas stripper, the charge state of the U-ions is increased from 4⁺, with 28⁺ being needed for further acceleration. Measurements with the N₂-jet show equilibrated charge state distributions for U on N₂ with an average charge state between 26⁺ and 27⁺ [4]. To increase the stripping

efficiency into the desired charge state (28⁺), the use of other stripper gases is explored. To use other promising stripper gases at sufficient gas density, the back-pressure on the gas inlet has to be increased. The limitations of the differential pumping system connecting the stripper to the accelerator hinder this approach using the laval nozzle [5].

For working with increased gas density with the current pumping setup, the laval nozzle was exchanged by a pulsed valve, which is the basis for a pulsed gas cell. The valve opens only when a beam pulse passes the gas stripper and closes immediately afterwards. Given the low beam duty cycle, this enables the use of much higher back-pressures on the gas inlet, which is assumed to lead to higher gas densities in the interaction zone. With this modified setup, the use of other stripper gases at sufficient gas densities appears possible.

The new modified setup was first tested early in 2014 with a Bi-beam using N₂ as a stripper gas [6]. Recently, another measurement series was conducted using an U-beam on H₂, He and N₂ and a yet improved setup.

EXPERIMENTAL SETUP

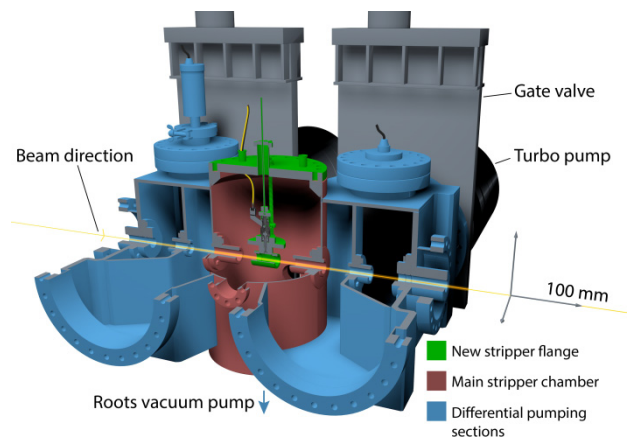

Figure 1: 3D model of the GSI UNILAC gas stripper.

The experimental setup that was used for these measurements is a modified version of the setup described in [6]. The basic parts of the GSI UNILAC gas stripper are depicted in Fig. 1. A four stage differential pumping system is used to achieve the required vacuum in the adjacent accelerator line. The major gas load is removed by a roots vacuum pump (2222 l/s) located directly below the main stripper chamber. The adjacent

stages of the differential pumping system are pumped down by four turbo pumps (1200 l/s each).

The flange on top of the main chamber was exchanged for a newly developed flange, featuring the pulsed gas valve. A 3D model of the new flange is shown in Fig. 2. The valve outlet is located very close to the beam trajectory, inside the main stripper chamber. The gas enters a T-fitting, aligned with the beam axis, which prevents instantaneous exhaustion of the gas through the roots vacuum pump. The length of the T-fitting in beam axis is 44 mm and can be varied; the aperture is 21 mm.

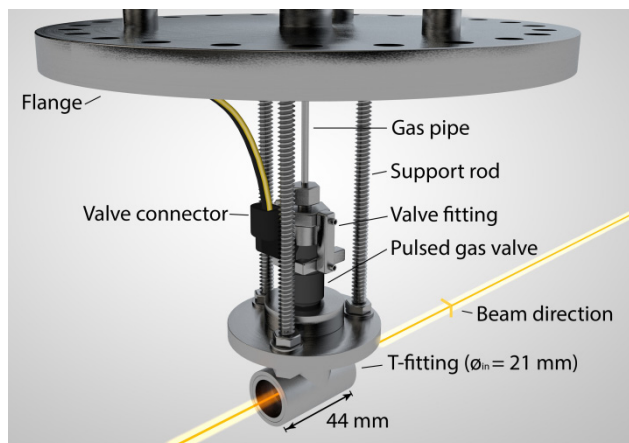

Figure 2: 3D model of the new stripper flange.

Opening of the valve is initiated by a timing signal from the main accelerator control unit, synchronized with the transit of the beam pulse. An opening time of 0.5 ms was used for the measurements.

Gas is supplied from standard 2 MPa gas bottles with a pressure regulator. For the measurements with H_2 , a specially designed safety valve system was used.

The beam current was measured using beam transformers in front of and behind the stripper. A dipole magnet directly after the stripper section enables charge state separation of the beam. A slit system allows selecting only the desired charge state. Charge states below 21^+ could not be measured because of the field-strength limitations of the dipole magnet.

The beam emittance was measured using a slit-grid system, as described in [7], and it is located behind the charge separation system. The energy-loss of the beam in the gas was determined from time of flight measurements using phase probes along the accelerator line.

To compare the stripping performance of the new setup with that of the N_2 -jet stripper, additional measurements were conducted using the stripper flange with the laval nozzle. For all measurements, a high-current $^{238}U^{4+}$ -beam was used with 100 μs beam pulse length and 1 Hz repetition rate.

EXPERIMENTAL RESULTS

First, the back-pressure on the valve was increased systematically up to 12 MPa for each gas to obtain an equilibrated charge state distribution. For this, the

evolution of the beam current was observed until saturation was reached.

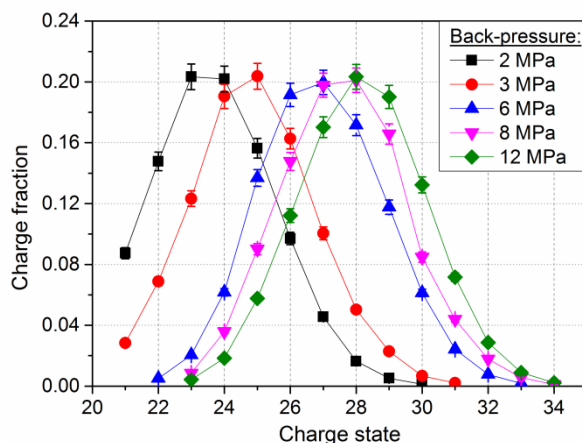

Figure 3: Charge state distribution for U on H_2 with increasing back-pressure on the gas inlet.

For N_2 and He, equilibrated charge spectra were measured within the applied pressure range. For H_2 , an equilibrated charge state distribution could not be obtained, cf. Fig. 3. The back-pressure was increased from 2 MPa to 12 MPa. The average charge state increased from about 23^+ at 2 MPa to about 28^+ at 12 MPa. The width of the distribution remained the same within the uncertainty range. From the trend of the charge state evolution, saturation at a back-pressure of about 18 MPa is expected. As only charge states above 21^+ could be measured, the charge state distributions for 2 MPa and 3 MPa were normalized to the maximum charge fraction, which was determined absolutely.

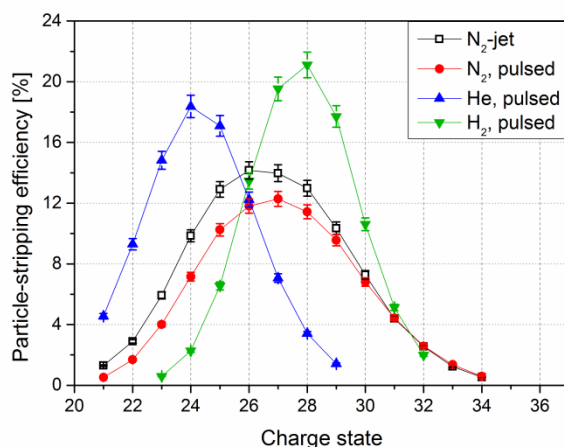

Figure 4: Measured stripping efficiencies for U on H_2 , He and N_2 using the pulsed gas cell (full symbols) and the N_2 -jet (open symbols); all distributions except for H_2 are equilibrated, suggesting that even higher charge states can be populated with H_2 at higher gas densities. Lower efficiencies for pulsed N_2 compared to the N_2 -jet are caused by decreased transmission.

To compare stripping performances, the stripping efficiency, which is the fraction of ions in a specific

charge state in relation to the total number of ions in front of the stripper, was measured for the equilibrated charge state distributions with the N₂-jet and He, N₂ (all saturated) and H₂, at 12 MPa (not saturated), using the pulsed gas cell. The stripping efficiencies were measured separately for each charge state and are depicted in Fig. 4.

The comparison of N₂ (pulsed) with the N₂-jet shows overall lower stripping efficiencies at a similar average charge state. The transmission for N₂ (pulsed) is 85 % compared to 100 % transmission with the N₂-jet. For H₂, the transmission is 99 %. The error in the transmission measurement is ± 4 %.

The charge state distributions for He and H₂ are more narrow than for N₂. This was expected for low-Z gases as it was observed before. The narrow charge state distributions result in higher stripping efficiencies for the dominantly populated charge states. The equilibrated average charge state for He is about 24⁺, which is insufficient to reach desirable U²⁸⁺-intensities. For H₂, the highest measured average charge state at 12 MPa is about 28⁺.

Table 1: Comparison of the Stripper Performance for a High-current U-beam Using the N₂-jet and the Pulsed H₂ Gas Cell.

	N ₂ -jet	H ₂ , pulsed
Back-pressure	0.4 MPa	8 MPa
Maximum charge state	+26	+27
Particle-stripping efficiency into 28 ⁺	12.7(5) %	20.1(8) %
Energy-loss	20(5) keV/u	12(5) keV/u
Estimated thickness	44.9 μg/cm ²	9.3 μg/cm ²
Maximum U ²⁸⁺ -current	4.5 emA	7.8 emA
ε _x (90%, total) norm.	0.76(2) μm	0.70(1) μm
ε _y (90%, total) norm.	0.84(2) μm	0.93(2) μm
Beam brilliance (28 ⁺ , X)	5.32 mA/μm	10.03 mA/μm
Beam brilliance (28 ⁺ , Y)	4.82 mA/μm	7.55 mA/μm

A comparison of the new pulsed H₂ gas cell (8 MPa) and the N₂-jet is shown in Table. 1 (for more details, see [8]). Due to the narrow charge state distribution and the increased average charge state with the pulsed H₂ gas cell, the stripping efficiency into the 28⁺ charge state is increased significantly, resulting in an increased U²⁸⁺ beam current. An energy-loss of 20 ± 5 keV/u was measured for the N₂-jet, while it was 12 ± 5 keV/u for the pulsed gas cell with H₂ at 12 MPa back-pressure. The shown thicknesses were estimated from the measured energy-losses using LISE++ [9].

The beam emittance was measured in vertical and horizontal axis for the pulsed H₂ gas cell and compared to the N₂-jet. The horizontal beam emittance for the pulsed H₂ gas cell is slightly smaller than that of the N₂-jet; the

vertical beam emittance is slightly increased. The evaluated horizontal and vertical beam brilliance is increased significantly by using the pulsed H₂ gas cell.

CONCLUSIONS AND OUTLOOK

Charge state distributions of U beams after interaction with a variety of gases was measured, and the full results will be given in [10]. Here, we point out that for application, e.g., at the UNILAC, the measurements show especially promising results for the electron stripping of U with H₂. The stripping efficiency for the desired 28⁺ charge state could be increased from 12.7 % using the N₂-jet stripper to 20.1 % using the new pulsed gas cell with H₂ at 8 MPa back-pressure. The beam brilliance was significantly increased with the pulsed H₂ gas cell.

The measurements of the charge state distribution of H₂ indicate the possibility to achieve even higher average charge states if the gas density can be increased further. For this, an advanced setup with multiple gas valves, certified for higher back-pressures, is under construction. In separate off-line measurements the effective gas density of the pulsed gas cell will be measured.

The measurements with N₂ (pulsed) show a decrease of the transmission through the stripper, which is in agreement with earlier results obtained with a Bi-beam [6]. This may be caused by a non-optimized focusing of the beam with the new pulsed gas cell and will be investigated in future measurements.

ACKNOWLEDGEMENTS

The authors are grateful for the support of the GSI ion-source and UNILAC staff. This work was financially supported by the Helmholtz Institut Mainz and the GSI Helmholtzzentrum für Schwerionenforschung in Darmstadt, Germany. Stimulating discussions with V.P. Shevelko are gratefully acknowledged.

REFERENCES

- [1] FAIR Baseline Technical Report, Vol. 2, GSI Darmstadt, p. 335 (2006).
- [2] W. Barth et al., Nucl. Instrum. Methods Phys. Res. A 577: 211-214 (2008).
- [3] W. Barth, P. Forck, Proceedings of LINAC2000, 21th-25th August, Monterey, USA, p.235-237 (2000).
- [4] W. Barth et al., GSI internal note, 05.10.2007, Darmstadt, Germany (2007).
- [5] B. Schlitt et al., Proceedings of IPAC2013, 12th-17th May, Shanghai, China, 3779-3781 (2013).
- [6] P. Scharrer et al., J. Radioanal. Nucl. Chem., DOI 10.1007/s10967-015-4036-2 (2015).
- [7] G. Riehl et al., Proceedings of EPAC1990, 12th-16th June, Nice, France (1990).
- [8] W. Barth et al., Phys. Rev. ST Acc. Beams 18, 040101 (2015).
- [9] O. Tarasov and D. Bazin, Nucl. Instrum. Methods. Phys. Res., Sect. B 26, 4657 (2008).
- [10] P. Scharrer et al., in preparation.