

RFID Based Smart Shopping Trolley with PCB Design

Harika P, Meghana S, Rohit Chavan, Swaroop S Atre

Department of ECE, NIE Mysore
Mananthavadi Road, Vidyaranyaapuram, Mysore 570001, Karnataka, India.

Ms. Sharmila B S Assistant prof. Department of ECE

Abstract - Shopping is captivating and addictive, but standing in never-ending billing queues is a tiring process. Even though various online shopping platforms are growing, retail shopping has never stepped back. To ease the shopping process and eliminate lengthy billing queues, a new product has to be introduced with the appropriate use of technology. This paper summarizes a Radio Frequency Identification based smart shopping trolley that provides automatic billing and customer satisfaction. The RFID tags on the products are read by the reader present on the shopping cart. The display screen present in the cart provides the cost information and gives the final billing amount. This is then sent to the cashier's database using Wi-Fi module and hence saves the customer's time. This entire model is designed on the PCB and simulated.

1. INTRODUCTION

Shopping facilities or department stores offer a splendid comfort to consumers, wherein all the goods of various kinds are discovered. Nowadays, shopping is not only an essential requirement but likewise a way of reinvigoration. Shoppers face a lot of troubles all along with buying, resting in the line for the bill and most of the consumers are constrained with a budget. The majority of times buyer exceeds the budget and recognizes it during the billing, where removing the products at the end becomes a tedious task. Furthermore, tracking down the product is another struggle. With the progress in technologies, buyers likely procure products from establishment buying websites like Amazon, and Flipkart that take time to deliver and whose quality is doubtful.

The retailers are steadily active in improving the buying occurrence to make sure their consumers are pleased. To help them and enhance the experience, we propose a solution. A PCB embedded with RFID reader that scans the tags present on each product which the customer wants to purchase is included in the cart. Once properly scanned, the microcontroller present on the PCB receives the information and the LCD displays the details of the merchandise like cost, expiry date, etc. As the products are appended to the trolley

the combined cost is displayed on the LCD which in turn helps the consumers shop within budget and save their billing time. Addition and removal of the product are carried out smoothly with help of a push knob. Once the buying is accomplished the definitive bill is moved to the cashier's database using Wi-Fi module and the consumer can pay for the amount at the checkout. To make the whole arrangement more modest and incorporate, we consolidate every one of the gadgets onto a PCB board.

Subsequently, this work intends to plan and carry out RFID based smart shopping trolley which gives information about the products, increases consumer satisfaction and eventually improves the sales growth.

2. LITERATURE SURVEY

In [1] V. Anand et al. discuss the difficulties faced during PCB design and suggest appropriate methods to resolve them. They provide guidelines for placing the footprints to prevent overheating of the components which in turn damages the circuit board. Using appropriate mathematical formulas different parameters like trace length, external length, separation distance, and correction clearance are calculated. They discuss different shaped traces that are to be considered based on the parameters and track length using fine-tuning techniques. The main focus is on minimizing thermal effects and managing proper heat techniques. Designing the board with thermal relieving footprints and vias results in better cooling of the PCB. In addition, they describe a few hacks to increase potential insulation, reduce the heat flow, minimize copper wastage, etc. The open-source platform, KiCAD was used in designing the printed circuit board. In [2] T. K. Das et al. discussed an IoT-based trolley which provides the consumer a convenient way to shop. Customers self-scan the products and directly pay the bill. This model uses Arduino, RFID tags, a reader and a Wi-Fi module to communicate with the database. It also contains a webpage that keeps track of products and consumer's information. Product information is available in an

android mobile application. In [3] S. Kowshika et al. present a model that uses a Raspberry Pi microcontroller which controls the reader to scan the tags. This model ensures the safety by using a load cell to avoid any kinds of fraud or errors. A buzzer is activated when the non-scanned products are put inside the cart. An automatic bill is displayed on the LCD and the customer receives information on the mobile app. In [4] T. Naveenprabu et al. propose a system, which uses passive RFID tags instead of barcodes present on every item. The trolley follows the movement command given by the user using the mobile application. The bill is automatically calculated and is sent to the administrative system using LAN. The drawback of the system is that if there is any interruption with the trolley by another customer, then it might move in some other direction and there is no backup on the database. In [5] L. Syafa'ah et al. implement ESP8266 Wi-Fi module to control devices like fans, lamp, doors etc using HTTP protocol. Programming is done such that it is simple and easily understandable to minimize response time and resources. The response time of the device is calculated i.e., the amount of time it takes for the command given through the server to reach the device. The maximum distance where ESP866 module can operate from the Wi-Fi access point is also measured. In [6] Pachiappan et al. compare RFID and barcode technology. When it comes to line-of-sight, barcode scanners are slow and difficult to read. RFID tags are used to avoid this. The whole bill was displayed on the display unit after scanning product details. The database and the controller are communicated using Zig bee. The GSM module is used to track down the customer's phone and communicate billing information to them. In [7] M. Abu Khater gives a basic overview of the issues that arise while building PCBs with excellent performance and speed. He explains how to create professional layouts using widely used approaches. Wherein this article offers sound advice on how to build a PCB with excellent performance, it does not replace the requirement for design tests and check simulations. Additionally, functional designs must be considered by PCB designers in order to facilitate assembling and testing operations. In [8] S. Kamble et al. talks on how to apply Radio Frequency Identification systems in many industries, further research and customized solutions are necessary. Inserting UHF RFID tags into a PCB board is time-consuming, as the location, size, and efficiency of the tags change with each new configuration. Most IoT applications employ a PCB design as it is more compact.

3. SYSTEM DESIGN

3.1. PCB (Printed Circuit Board)

A printed circuit board is a structure on which electronic circuitry is mounted. The circuitry contains traces (metal wires) and planes (larger areas of metal). The electrical elements are

soldered to the top or bottom surface or both. The PCB can be made up of a simple single layer or complex multiple layers. To design a PCB, designing and routing rules must be followed to avoid unwanted capacitance and inductance. Positioning of components is done in such a way that resistance and dimensions between connecting points are minimum. Setting aside or distribution of the components based on the large range of floor planes present on the board is another consideration. For components using high voltage maintain enough clearance for proper isolation, and wide traces for high current components for proper cooling. For rapid and effortless production ensure that more are on the same side of the PCB. Avoid routing of high-frequency components to the bottom layer of the board. I/O lines are one of the most straightforward ways to transfer undesired energy. We have to minimize current loop areas and avoid circuitry between connectors.

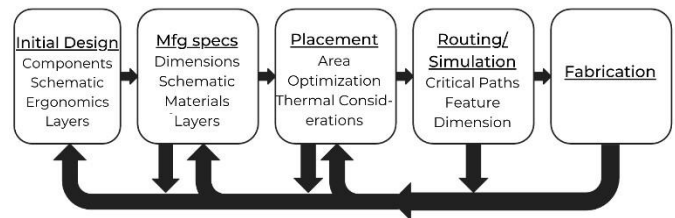

Fig1. Flowchart that depicts the design process of PCB

Many decisions must be made during the design of a PCB as in Fig.1, including schematic, dimensions of the PCB, number of layers, placement of the component and routing. After the successful completion, testing and fabrication is carried out. PCB designing is a looping and a repetitive process.

3.2. RFID (Radio Frequency Identification)

RFID is a data collecting system that uses electronic/digital tags to record data. Tags are identified by using electronic readers. There are two types of tags: Passive and Active tags. Passive tags do not have an internal power source while active tags are battery powered. When passive tags come in the vicinity of the reader, electromagnetic signals are generated to activate the tag and information is obtained.

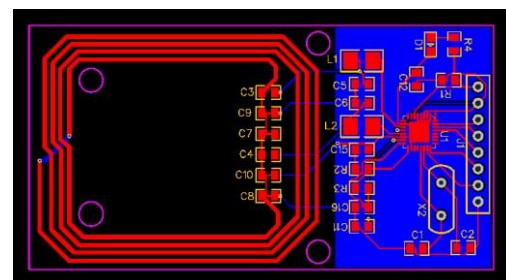

Fig.2. RFID RC522 reader PCB design

The designed PCB model for RFID reader as in Fig.2 has MRFC522 IC chip, antenna, I/O and power pins and an

oscillator. MRFC522 is a multimedia resource function controller which is the main controlling unit of the reader. It operates at 13.56 MHz for contactless communication. The microstrip antenna present in RC522 has a spiral geometric form through which bandwidth widens. The main purpose of the antenna is to convert current into EM waves, this wave is detected by the tag and hence the information is shared. The I/O and power pins include VCC (3.3V), RST (reset), GND, IRQ (Interrupt), MISO, MOSI, SCK (clock), SS. A 27.12 MHz quartz crystal oscillator produces continuous electric waves. The operating frequency (13.56 MHz) of RFID is procured by dividing 27.12 MHz by 2.

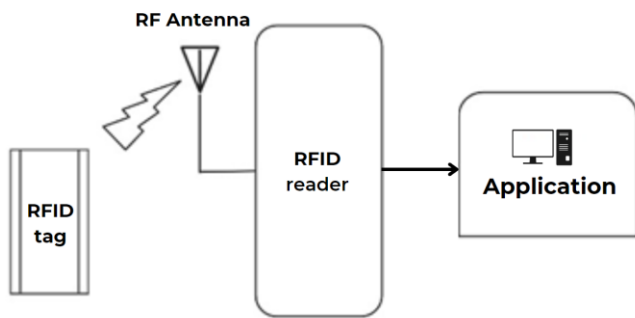

Fig.3. Working of the RFID module

The RFID consist of three main components namely Transponder (tag of RFID), Interrogator (RF reader), and Antenna. A radio signal is produced by the microstrip antenna that activates the RFID tags. They absorb electrons from the reader and transfer them in the form of electromagnetic waves to nearby RFID tags. Data is detected by the sensor tags, which may subsequently be read by the RFID reader. Communication between the tag and transceiver is achieved via antenna. A flux is induced in the reader when tags are in close proximity of the EM waves. As a result of this flux, power is generated in the tag. The interrogators read data from RFID tags, with one acting as master and the other as slave respectively. The information read by the reader can be applied in any application required.

In Table 1, we have compared our RFID design with several other designs. Comparison of length, width, antenna (length and shape), range are carried out. In [13] Wu xunxun's model of RFID has UHF RFID reader R600 of dimension 218x160 and operating range of up to 5m. In [11] Md Norzeli et al. In their model of RFID, it consists of a microstrip Antenna with dimension 76.7x 98.7 and of E-shaped microstrip antenna. In [12] S. Mazunder et al. This model of RFID has dimension 60x30 with a Spiral Antenna. In [26] Amarai et al. have talked about a Folded dipole antenna of dimension 70x20 and operates at a frequency of 40 MHz. In [27] Abdulhadi at al. have used RI-UHF-IC-116-00 of Dimension 126x126 using a Patch

Antenna of an operating range up to 9m. In our proposed model, we have designed an RFID-RC522 reader module with dimensions 70x38 with Spiral shaped antenna length of approximately 500mm operating at a frequency of 13.56MHz and a range of up to 1m.

Table 1. Comparison table of RFID

Reference	Module	Length (mm)	Width (mm)	Antenna Dimensions (mm)	Operating frequency (MHz)	Antenna Shape	Operating Range (mm)
[13]	R600	218	160	18x42	865-868	Meander-line	Up to 5000
[11]	Microstrip antenna	-	-	76.7x 98.7	860-960	E shaped microstrip	-
[12]	RDM880 SE RFID reader	60	30	500	13.56	Spiral	30-100
[26]	NXP UCODE G2iL series	150	200	70x20	40	Folded dipole	70
[27]	RI-UHFIC-11600	126	126	59x79	915	Patch	Up to 9000
Our proposed model	RFID-RC522	70	38	502.3	13.56	Spiral	Up to 1000

3.3. Wi-Fi Module

The ESP8266 Wi-Fi module is a security operation centre by itself. It has an inbuilt TCP/IP protocol to access Wi-Fi. Using IEEE 802.11bgn, this module allows connection between microcontroller and Wi-Fi (2.4 GHz). Microcontrollers use AT commands for the communication.

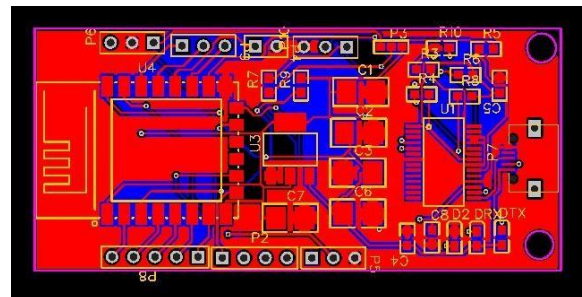

Fig.4. ESP8266 NodeMCU Wi-fi module PCB design

The designed Wi-fi module as in Fig.4 has ESP8266 IC chip, flash memory, LED's, antenna, 26MHz crystal oscillator, I/O and power pins, USB Connector (micro-USB). ESP8266 has extra low power consumption with 80-160 MHz clock speed. Through GPIO's it can be connected to sensors and other device. It is also embedded with a memory controller. The

external flash memory of 4 MB is used to store the user program. Crystal oscillators provide stable clock signals. It can be operated in the temperature range of -40°C to 125°C. The power pins include VIN pin and three 3.3V pins. The I/O pins include RST, GND, TX, RX, CH_PD (chip enable), 17 GPIO pins.

3.4. MICROCONTROLLER

Arduino UNO is a microcontroller board which uses ATmega328P. It is of low cost and can be programmed easily. The board is used in IOT projects and can be interfaced with many electronic gadgets like LED's, sensors or other microcontroller boards.

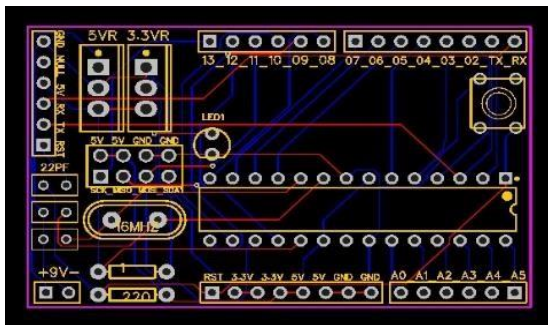

Fig.5. Arduino UNO PCB design

The designed Microcontroller as in Fig.5 has ATmega328P, 14 I/O pins, 6 Analog pins, 16 MHz Resonator. The ATmega328P MCU operates at a voltage of 5V. It also consists of 32KB of Flash Memory, 2KB of SRAM and 1KB of EEPROM.

3.5. INTEGRATION OF PCB's

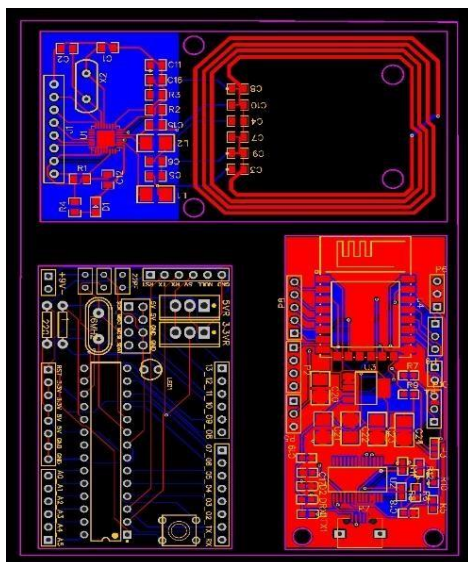

Fig.6. PCB design

All these PCB designs are integrated on a single board such that the cost of fabrication of each PCB reduces. Connecting all three PCB's separately on the trolley would be an inconvenience. So, we have all the PCB's integrated on a single board and fixed to the trolley. Fig.6 shows the integration of our PCB designs.

4. IMPLEMENTATION

Our proposed model makes billing effortless and very reliable and saves customer's time. Customers needn't wait in the long lasting billing counters instead the bill is simultaneously generated during shopping [3]. The following block diagram represents the working of the proposed model

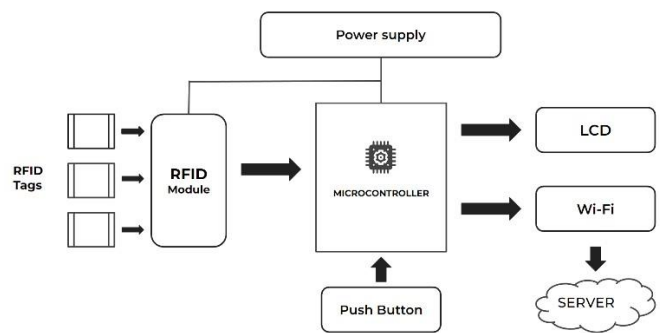

Fig.7. Design of the model proposed

4.1. Hardware and Software implementation As shown in Fig.7, The power supply is given to the microcontroller and RFID reader. Barcodes on each product are replaced by unique RFID tags. The product amount is added to the bill when the RFID tag of each item is read by the reader. RFID operates at 13.56 MHz providing huge bandwidth and data can be sent to far distances in less time. The scanned item information from the RFID tag is fed into the Arduino which displays it on the LCD. The microcontroller is also programmed to calculate the bill amount simultaneously as products are added to the trolley. The LCD screen displays real-time information. It includes product details like cost, expiry date, calories and nutrition facts, etc. The total bill amount is also displayed on the screen for the user to maintain his/her budget. In case the user wants to remove a scanned product, they have to push the button and rescan it. This automatically deducts the price and the new bill is calculated. Once the purchasing is done it sends the total bill amount to the cashier's database using Wi-Fi module. All these hardware components are consolidated into a single PCB to make the entire setup more compact and efficient.

5. SIMULATION RESULTS

The components are connected as shown in Fig.8. The Arduino UNO is connected to a transmitter and a receiver which acts as a tag and reader. And further a push button is added for addition and deletion of the products from the list. Two LEDs are also connected where one turns YELLOW when a product is added and the other one turns RED if its removed.

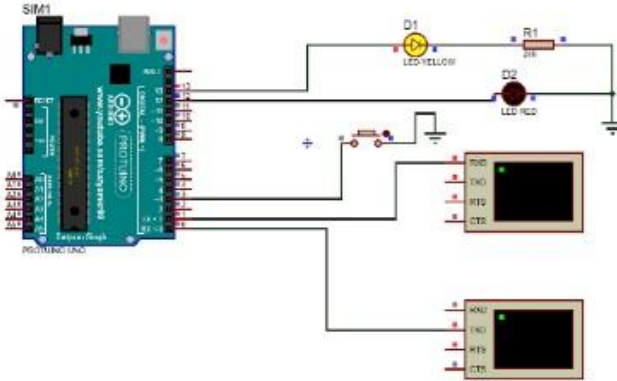

Fig.8. Simulation of the model

The simulation is carried out and the results are as shown in Fig.9. It performs accurately and displays the following information, ID, whether the ID is valid or not, details of the product (Price, Exp date), total price and total number of products. It adds and deducts the amount as and when the products are added or removed and displays 'invalid' when an invalid ID is scanned. Further simulation using Wi-fi module is being carried out.

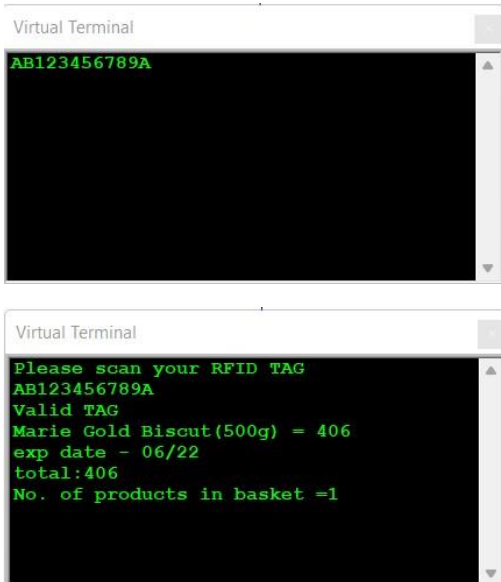

Fig.9. Result of the Simulation

CONCLUSION

Nowadays, with the traditional method of shopping, lot of time is wasted in the billing queues as barcodes are being used. Our proposed solution to this is to use RFID technology. Once the product is scanned properly, its information is displayed on the LCD present on the trolley. This approach hence calculates the bill amount simultaneously and sends the billing information to the database. This model is more compact because all the modules namely RFID reader, Wi-Fi module and microcontroller are embedded on a single PCB. In addition to the technology used, the use of PCB makes the model more efficient, compact and durable. Incorporating RFID-based shopping thus opens doors for improving technology, efficiency, and customer satisfaction. Thus, this technology based model attracts more customers.

FUTURE SCOPE

This proposed model can be improved by creating a mobile application that stores all the product information including the stock and location of the product. Using Artificial Intelligence, various suggestions and new features can also be added to attract more customers. By introducing Online payment methods in the system, the customer can further save time by directly paying the bill and needn't even wait at billing counters. In the security aspect, it must guarantee secure online transactions. We can also add voice assistance for further simplicity. Different other technologies like robotics and AI can be integrated to develop this model. In addition, preventing theft and increasing security might prove an important area for future research. Further, the model can also be modified to help differently-abled and elderly customers.

REFERENCES

- [1] V. Anand, V. Singh and V. K. Ladwal, "Study on PCB Designing Problems and their Solutions," 2019 International Conference on Power Electronics, Control and Automation (ICPECA), 2019, pp. 1-5, doi: 10.1109/ICPECA47973.2019.8975402.
- [2] T. K. Das, A. K. Tripathy and K. Srinivasan, "A Smart Trolley for Smart Shopping," 2020 International Conference on System, Computation, Automation and Networking (ICSCAN), 2020, pp. 1-5, doi: 10.1109/ICSCAN49426.2020.9262350
- [3] S. Kowshika, S. S. Madhu mitha, G. Madhu Varshini, V. Megha and K. Lakshmi, "IoT based Smart Shopping Trolley with Mobile Cart Application," 2021 7th International Conference on Advanced Computing and Communication Systems (ICACCS), 2021, pp. 1186-1189, doi:

- 10.1109/ICACCS51430.2021.9441866
- [4] T. Naveenprabu, B. Mahalakshmi, T. Nagaraj, N. Kumar S.P. and M. Jagadesh, "IoT Based Smart Billing and Direction Controlled Trolley," 2020 6th International Conference on Advanced Computing and Communication Systems (ICACCS), 2020, pp. 426-429, doi: 10.1109/ICACCS48705.2020.9074173
- [5] L. Syafa'ah, A. E. Minarno, F. D. S. Sumadi and D. A. P. Rahayu, "ESP 8266 For Control And Monitoring In Smart Home Application," 2019 International Conference on Computer Science, Information Technology, and Electrical Engineering (ICOMITEE), 2019, pp. 123-128, doi: 10.1109/ICOMITEE.2019.8921287.
- [6] Pachiappan, Kalaivani & Chinnasamy, Rajan & S, Sandhiya. (2019). An Automated Billing System in Shopping Malls Using Bascart. Bulletin of Scientific Research. 1. 62-68. 10.34256/bsr1919
- [7] M. Abu Khater, "High-Speed Printed Circuit Boards: A Tutorial," in IEEE Circuits and Systems Magazine, vol. 20, no. 3, pp. 34-45, thirdquarter 2020, doi: 10.1109/MCAS.2020.3005484.
- [8] S. Kamble, S. Meshram, R. Thokal and R. Gakre, "Developing a Multitasking Shopping Trolley Based on RFID Technology", International Journal of Soft Computing and Engineering, Vol.3, No.6, pp.179-183.2014
- [9] F. Shahina C.A. and S. A. Kabeer, "Smart Access Card system to mitigate the Covid-19 Outbreak," 2021 2nd International Conference on Computation, Automation and Knowledge Management (ICCAKM), 2021, pp. 168-173, doi: 10.1109/ICCAKM50778.2021.9357755.
- [10] N. Karna, D. Pratama and M. Ramzani, "Self Service System for Library Automation : Case Study at Telkom University Open Library," 2019 International Conference on Information and Communications Technology (ICOIACT), 2019, pp. 689-693, doi: 10.1109/ICOIACT46704.2019.8938439.
- [11] Mohd Norzeli, Syamimi & Ismail, Izwani & Fazruisyam, Mohd & Busu, Mohd. (2012). Designing an UHF RFID Reader Antenna.
- [12] S. Mazumder, V. K. Rakesh and T. Samanta, "Design and development of a hand-held RFID reader for recording attendance," 2012 5th International Conference on Computers and Devices for Communication (CODEC), 2012, pp. 1-4, doi: 10.1109/CODEC.2012.6509219.
- [13] Wu xunxun, "Design of Passive UHF RFID Tag Antennas and Industry Application," 2010.
- [14] I. B. Shirokov, "Increasing of Operation Range of RFID System," 2019 IEEE International Conference on RFID Technology and Applications (RFID-TA), 2019, pp. 337-341, doi: 10.1109/RFID-TA.2019.8892189.
- [15] A. Tzitzis et al., "Real-time 3D localization of RFIDtagged products by ground robots and drones with commercial off-the-shelf RFID equipment: Challenges and Solutions," 2020 IEEE International Conference on RFID (RFID), 2020, pp. 1-8, doi: 10.1109/RFID49298.2020.9244904.
- [16] Sumanth Kasula, "IoT based Smart Cart using RFID and NodeMCU", Kakatiya Institute of Technology & Science, Warangal, August 2021.
- [17] S. Shailesh, P. Shrivastava Deb, R. Chauhan and V. Tyagi, "Smart Trolley," 2021 International Conference on Advance Computing and Innovative Technologies in Engineering (ICACITE), 2021, pp. 242-245,
- [18] M. Sanap, P. Chimurkar and N. Bhagat, "SMARTSmart Mobile Autonomous Robotic Trolley," 2020 4th International Conference on Intelligent Computing and Control Systems (ICICCS), 2020, pp. 430-437, doi: 10.1109/ICICCS48265.2020.9120972.
- [19] T. R. Lekhaa, S. Rajeshwari, J. A. Sequeira and S. Akshayaa, "Intelligent Shopping Cart Using Bolt Esp8266 Based on Internet of Things," 2019 5th International Conference on Advanced Computing & Communication Systems (ICACCS), 2019, pp. 758761, doi: 10.1109/ICACCS.2019.8728346.
- [20] R. Nishitha, S. S. Naik, V. Raksha and U. Kulsum, "IoT Based Automatic Billing System Using Barcode Scanner by Android Device and Monitoring Unregistered Barcode by RFID," 2019 4th International Conference on Recent Trends on Electronics, Information, Communication & Technology (RTEICT), 2019, pp. 15-20, doi: 10.1109/RTEICT46194.2019.9016698.
- [21] A. N. S. Al Julandani, F. Q. Canlas and S. Nair, "'Do It Yourself' Product Scanning System for Supermarket Customers with Anti-Theft Feature: A Proposed Model," 2020 International Conference on Computing, Networking, Telecommunications & Engineering Sciences Applications (CoNTESA).
- [22] T. Arciuolo and A. -s. Abuzneid, "Simultaneously Shop, Bag, and Checkout (2SBC-Cart): A Smart Cart for Expedited Supermarket Shopping," 2019 International Conference on Computational Science and Computational Intelligence (CSCI), 2019, pp. 1162-1167, doi: 10.1109/CSCI49370.2019.00219.

- [23] S. Mekruksavanich, "Supermarket Shopping System using RFID as the IoT Application," 2020 Joint International Conference on Digital Arts, Media and Technology with ECTI Northern Section Conference on Electrical, Electronics, Computer and Telecommunications Engineering (ECTI DAMT & NCON), 2020.
- [24] W. Shalannanda, I. Zakia, F. Fahmi and E. Sutanto, "Implementation of the Hardware Module of IoTbased Infant Incubator Monitoring System," 2020 14th International Conference on Telecommunication Systems, Services, and Applications (TSSA, 2020, pp. 1-5, doi: 10.1109/TSSA51342.2020.9310901.
- [25] J. Ambareen, P. M and T. Ara, "Edge Data Security for RFID-based Devices," 2020 International Conference on Smart Technologies in Computing, Electrical and Electronics (ICSTCEE), 2020, pp. 272277, doi: 10.1109/ICSTCEE49637.2020.9277007.