

Preface

This document presents the Executive Summary, the first of six volumes comprising the 2006 Baseline Technical Report (BTR) for the international FAIR project (Facility for Antiproton and Ion Research). The BTR provides the technical description, cost, schedule, and assessments of risk for the proposed new facility. The purpose of the BTR is to provide a reliable basis for the construction, commissioning and operation of FAIR. It is, in this sense, primarily a technical document. The science case for the various areas of research to be performed at FAIR is summarized in the introductions to the respective Volumes 3 to 5 of the BTR describing the experimental facilities. For additional information and discussion, we refer to the original Conceptual Design Report (CDR) and a series of subsequent collaboration workshops and papers to be found at the FAIR website (<http://www.gsi.de/fair>).

The BTR is one of the central documents requested by the FAIR International Steering Committee (ISC) and its working groups, in order to prepare the legal process and the decisions on the construction and operation of FAIR in an international framework. It provides the technical basis for legal contracts on contributions to be made by, so far, 13 countries within the international FAIR Consortium. The International Steering Committee as well as its working groups have been established under the umbrella of a Memorandum of Understanding for the preparatory phase of FAIR, signed by representatives from the 13 countries.

The BTR begins with this extended Executive Summary as Volume 1, which is also intended for use as a stand-alone document. The Executive Summary provides brief summaries of the accelerator facilities (BTR Volume 2), the scientific programs and experimental stations (BTR Volumes 3-5), civil construction and safety (BTR Volume 6), and of the work-project structure, costs and schedule. For the latter, more details are laid down in the Cost Book, a document separate from the BTR with restricted and controlled distribution. These technical documents, BTR and Cost Book, were prepared from contributions by the various experiment collaborations and the FAIR accelerator team, under the guidance of the Working Group on Scientific and Technical Issues (STI) and its subcommittees. The respective authors of the various contributions are listed in the respective BTR volumes and at the end of this Executive Summary. Separate documents describe the management structure and legal framework. The latter documents are under preparation by the FAIR International Steering Committee and its Working Groups on Administrative and Financial Issues (AFI).

The appendix to the present Executive Summary lists

- i. the 13 countries and their respective representatives that have signed the FAIR Memorandum of Understanding;
- ii. the representatives from the 13 countries of the International Steering Committee (ISC), and
- iii. the members of its Working Groups on Scientific and Technical Issues (STI), on Administrative and Financial Issues (AFI), and of the sub-committees to these working groups.
- iv. the lists of authors of the various experimental proposals and their institutional affiliations.

FAIR Baseline Technical Report

Volume 1 Executive Summary (this Report)

available on CD (attached to the inside of the back of this Report)

Volume 1 Executive Summary

Volume 2 Accelerator and Scientific Infrastructure

Volume 3A Experiment Proposals on QCD Physics

3.1 CBM - Compressed Baryonic Matter Experiment

Volume 3B Experiment Proposals on QCD Physics

3.2 PANDA - Strong Interaction Studies with Antiprotons

3.3 PAX - Antiproton/Proton Scattering Experiments with Polarization

3.4 ASSIA- Spin-dependent Interactions with Antiprotons

Volume 4 Experiment Proposals on Nuclear Structure and Astro Physics (NUSTAR)

4.1 LEB-SuperFRS - Low-Energy Branch of the Super-FRS

4.2 HISPEC/DESPEC - High Resolution In-Flight and Decay Spectroscopy

4.3 MATS - Precision Measurements of Very Short-Lived Nuclei Using an Advanced Trapping System for Highly-Charged Ions

4.4 LASPEC - Laser Spectroscopy of Radioactive Isotopes and Isomers

4.5 R3B - Reactions with Relativistic Radioactive Beams

4.6 ILIMA - Isomeric Beams, Lifetimes and Masses

4.7 AIC - Antiproton-Ion Collider

4.8 ELISE - Electron-Ion Scattering

4.9 EXL - Exotic Nuclei in Light-Ion Induced Reactions

Volume 5 Experiment Proposals on Atomic, Plasma and Applied Physics (APPA)

5.1 SPARC – Atomic Physics with Stored High Energy Ion Beams

5.2 HEDgeHOB - High Energy Dense Matter Generated by Heavy Ion Beams

5.3 WDM - Radiative Properties of Warm Dense Matter

5.4 FLAIR - Facility for Low-Energy Antiproton and Ion Research

5.5 BIOMAT - High-Energy Irradiation Facility for Biophysics and Materials Research

Volume 6 Civil Construction and Safety

Volumes 2 to 6 are not available in print

<http://www.gsi.de/fair/reports/btr.html>



Facility for Antiproton and Ion Research

FAIR

Baseline Technical Report

Executive Summary

Editors

H. H. Gutbrod (Editor in Chief)

I. Augustin, H. Eickhoff, K.-D. Groß, W. F. Henning, D. Krämer, G. Walter

September 2006

ISBN
EAN

3-9811298-0-6
978-3-9811298-0-9

Executive Summary – Table of Contents

Preface	1
1. Introduction	6
2. FAIR Accelerator Facility	9
2.1 Overview	9
2.2 FAIR Performance Requirements and Basic Facility Concept	10
2.3 Technical Description of the FAIR Accelerator Facility	11
2.4 Modifications to the Conceptual Design Report	12
2.5 Parallel Operation and Synergy	13
2.6 Technological Challenges	14
3. Experimental Programs and Collaborations	15
3.1 Overview	15
3.2 Nuclear Structure, Astrophysics and Reactions with Rare-Isotope-Beams - the NUSTAR Collaboration	18
3.2.1 Physics Case	18
3.2.2 The Rare-Isotope-Beam Facility at FAIR	19
3.2.3 Experiments at the Rare-Isotope-Beam Facility	21
3.3 Hadron Physics with Antiproton Beams - the PANDA Collaboration	22
3.3.1 Physics Motivation	22
3.3.2 Research Program	22
3.3.3 Instrumentation and Detector	24
3.3.4 Interaction Region	24
3.3.5 Target Spectrometer	25
3.3.6 Forward Spectrometer	26
3.3.7 Data Acquisition and Trigger	26
3.4 The Phase Diagram of Strongly Interacting Matter - the CBM Collaboration	27
3.4.1 Exploring the QCD Phase Diagram with Heavy-ion Collisions	27
3.4.2 The Scientific Goals of the CBM Experiment	29
3.4.3 The CBM Detector Concept	29
3.4.4 Feasibility and Performance Studies	30
3.5 High Energy Density Bulk Matter Generated with Intense Heavy Ion and Laser Beams - the HEDgeHOB and the WDM Collaboration	31
3.5.1 Physics Motivation	31
3.5.2 Research Program	31
3.5.3 Instrumentation at FAIR	32
3.6 Atomic and Fundamental Physics with Highly Charged Ions and Antiprotons - the SPARC and the FLAIR Collaborations	33
3.6.1 Atomic Physics with Highly Charged Ions	33
3.6.2 Instrumentation for SPARC	33
3.6.3 Physics with Low-Energy Antiprotons	34
3.6.4 The FLAIR Facility	35
3.7 High-Energy Irradiation Facility for Biophysics and Materials Research - the BIOMAT Collaboration	36
3.7.1 Science Case	36
3.7.2 The BIOMAT Irradiation Facility	37
3.8 Offline Computing for FAIR Experiments	38

4. Civil Engineering	39
5. Radiation Safety Aspects	41
5.1 Radiation Safety Requirements	41
5.2 The Radiation Shielding Plan for FAIR	42
5.3 Radiation Protection Concerning the Emission of Radio-Nuclides	42
6. Organisation of FAIR as International Project	43
6.1 International Steering Committee (ISC)	43
6.2 Working Group on Scientific and Technical Issues (STI)	43
6.3 Working Group on Administrative and Funding Issues (AFI)	45
7. Costs and Schedule	49
7.1 Overview	49
7.2 Costs of the Accelerator Complex	50
7.3 Civil Construction Costs for Accelerator and Experimental Buildings	50
7.4 Costs of the Construction of the Experiments	50
7.5 Total Construction Cost	51
7.6 Schedule	53
7.7 Critical Path	53
7.8 Manpower - Resource Loaded Schedule	55
7.9 Budgetary Aspects	55
7.9.1 Spending Profile	55
7.9.2 Risk budget	56
7.10 Commissioning	56
7.10.1 Start of commissioning	56
7.10.2 End of Commissioning	57
7.11 Operation	57
8. Conclusion and Outlook	61
9. Appendix	63

1. Introduction

In 2001, GSI, together with a large international science community, presented a Conceptual Design Report (CDR) for a major new accelerator facility for beams of ions and antiprotons in Darmstadt. The concept for the new facility, now named FAIR (Facility for Antiproton and Ion Research), was based on extensive discussions and a broad range of workshops and working group reports, organized by GSI and by the international user communities over a period of several years. It also adopted priority recommendations, independently made by high level science committees, both national and international, on fields of science addressed by the proposed new facility.

Subsequent to an in-depth evaluation of the proposal by the German Wissenschaftsrat (the highest-level science advisory committee to the German government) and its recommendation to realize the facility, the Federal Government gave conditional approval for construction of FAIR in February 2003. The approval was contingent upon the following conditions. (i) a scientific-technical plan for a staged construction, and (ii) participation of international partners contributing at least 25 % to the construction cost.

Since then the project has gone through several major stages of development and significant progress has been achieved with regard to the scientific-technical and the political preparation of the project. This Baseline-Technical Report (BTR) for FAIR is an important result of this process and progress.

The scientific-technical and the science-political processes have been closely linked to each other. To steer and coordinate all preparatory activities, an international committee structure, led by the International Steering Committee (FAIR-ISC), was established for FAIR with representatives of ministries or funding agencies from, so far, 13 countries: China, Finland, France, Germany, Greece, India, Italy, Poland, Romania, Russia, Spain, Sweden, and United Kingdom. These countries have signed a Memorandum of Understanding for FAIR which provides the framework for scientific-technical cooperation during the preparatory period 2004-2006 and expresses the explicit intent of the members to participate in the construction and science use of FAIR.

In order to prepare the construction of FAIR with international cooperation, the members of the ISC agreed that a set of documents should be developed by spring 2006, on scientific and technical issues on the one hand and on administrative and funding issues on the other.

These documents provide the basis for a decision on the construction and operation of FAIR in an international legal framework and for contracts on contributions to be made by the partner countries. The BTR is one of these documents. It provides the technical description, cost, schedule, organizational structure, and assessment(s) of risk for the international FAIR project. The purpose of the BTR is to provide a reliable basis for the construction, commissioning and operation of the proposed facility and for its science use.

The ISC has formed two working groups, the Working Group for Scientific and Technical Issues (STI) and the Working Group on Administrative and Funding Issues (AFI). These working groups formed several sub-groups and sub-committees: scientific, technical and administrative advisory committees with expertise regarding the proposed research programs, the facility design, cost and legal issues, etc. (for details see Chapter 6). Based on this committee and sub-committee structure the specific mandate of the STI Working Group included:

- Definition of the scientific program: In a letter-of-intent and subsequent technical proposal process (during 2004/2005) STI, with the help of program advisory committees (PACs), evaluated and rated the proposed research programs and experimental facilities. Resulting from this comprehensive evaluation process, STI worked out a detailed plan defining the experiments which should be part of base programs and be included into the core facility funding. The BTR describes these experiments.
- Definition of the layout and technical design of the FAIR accelerator facilities: In parallel to the scientific review, the proposed accelerator facility was technically evaluated with the help of a Technical Advisory Committee (TAC) and expert sub-groups, taking into account also proposed modifications and additions to the original design that were made in order to optimize operation and accommodate further programs. Resulting from this evaluation process, beam specifications of certain accelerator rings were modified and the topological layout of the facility was considerably re-designed. The BTR describes this re-designed facility lay-out, its technical components and its performance characteristics.
- Determination of costs and schedule for the construction and operation of FAIR: After setting up a general costing scheme (which was defined

by the AFI working group and its expert sub-panel on Full Costing Issues, FCI), STI, assisted by two cost review panels, evaluated the costs for the accelerator and experimental facilities, as well as for civil construction. It also reviewed the operation costs for the facility. The detailed results on costs and schedule are specified in the Cost Book which was prepared together with this BTR (with restricted and controlled distribution).

The specific mandate of the AFI Working Group and its sub-committees included:

- Development of, and recommendations on, an adequate legal structure of FAIR: According to the present considerations, FAIR will be organized as a limited liability company based on German law (GmbH, "Gesellschaft mit beschränkter Haftung"). The Fair GmbH is supposed to cooperate closely with GSI for construction and operation of the FAIR facility (on a contractual basis as will be the case with all other participating institutions). In this way, optimal use shall be made of the know-how and experience existing at GSI and other partner laboratories.

Further details will be stipulated in the Convention, Articles of Association, and the By-Laws under which FAIR will be set up.

- Preparation of legal contracts for contributions to be made by the partner countries: draft versions for these contracts have been developed by the AFI Working Group and the ISC, to be presented to the respective governmental authorities in the partner countries.

In parallel to the preparatory activities coordinated by the FAIR committees, research and development for the FAIR accelerator and experimental facilities has considerably advanced. About 2500 scientists and engineers have been involved as authors in the preparation of the scientific and technical documents for FAIR. Particular emphasis on the accelerator side is on fast-cycling, superconducting magnets; ultra-high vacuum aspects for low charge-state operation; high-current beam operation and control; and on fast stochastic and (high-energy) electron cooling. Significant progress has been achieved and the principal feasibility of the proposed technical approaches have been demonstrated. Prototyping for

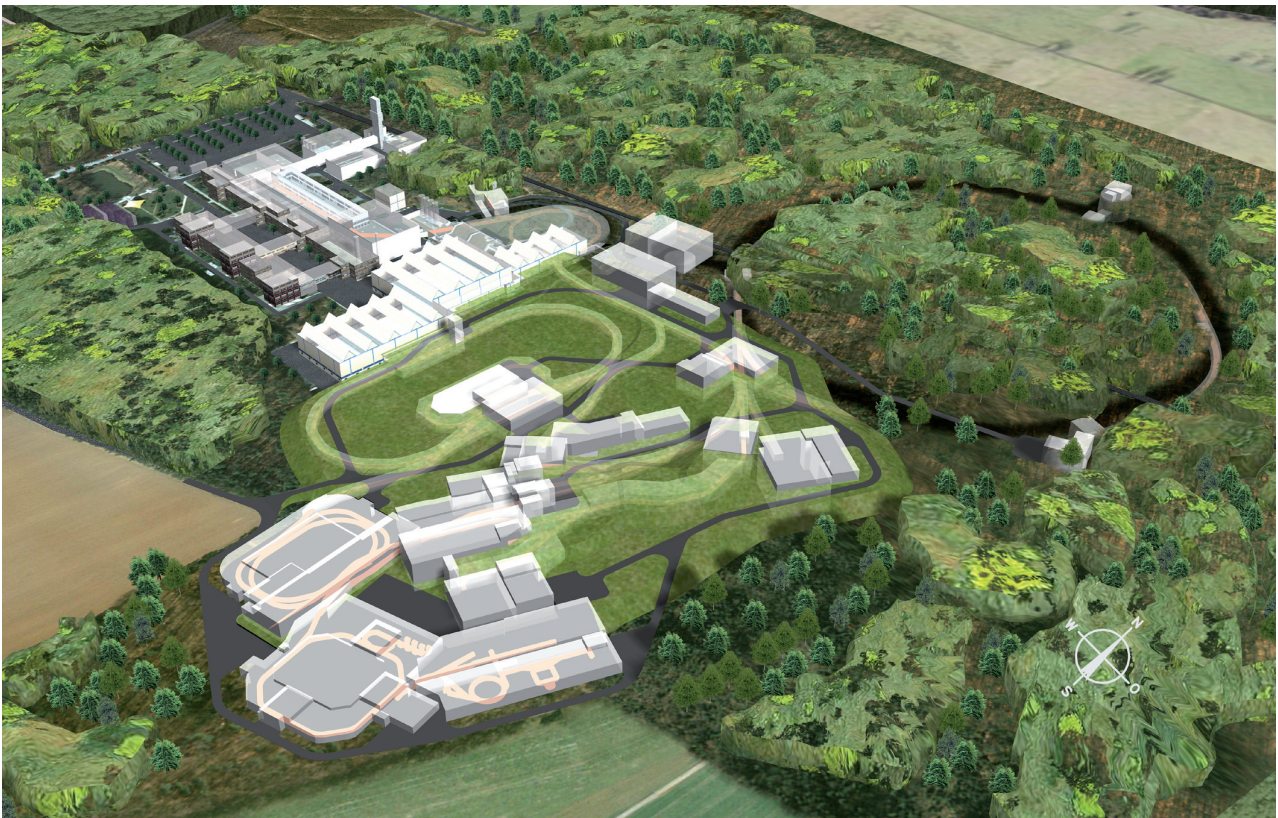

Figure 1.1: Artists view of FAIR. The synchrotrons on the right will be located 10 to 13 m underground and will not be visible in reality. Most of the roofs will be vegetated and thus most of the facility will be hidden from view.

superconducting magnets has started. The same holds for research and development towards the experiments planned at FAIR.

The legal procedures and technical planning associated with civil construction has also progressed. As a major step forward, the development plan for FAIR was recently formally approved by the Darmstadt City Council and the regional (district) authorities of the State of Hessen. Moreover, civil construction planning has been finalized taking into account the modified topology of the accelerators and experiments. Fig. 1.1 shows an artistic expression of the FAIR facility. The location of the facility can be seen in the regional map (Fig. 1.2).

The results presented in the BTR have been worked out in close collaboration between the international science community and the GSI Laboratory. They reflect the collective work of the FAIR community performed over the last 5 years since the publication of the FAIR CDR. About 2500 scientists and engineers from 45 countries have contributed to the progress and co-authored this BTR. They are listed individually in this Report, in the various technical proposals for experiments as well as in the technical reports for the accelerator work packages and technical infrastructures, and underline the broad involvement of the international research community in the preparations for FAIR.



Figure 1.2: The regional map shows the location of the FAIR facility in the State of Hessen in Germany.

2. FAIR Accelerator Facility

2.1 Overview

The concept of the FAIR Accelerator Facility has been developed by the international science community and the GSI Laboratory. It aims for a multifaceted forefront science program, beams of stable and unstable nuclei as well as antiprotons in a wide range of intensities and energies, with optimum beam qualities.

The concept builds and substantially expands on seminal developments made over the last 15 years at GSI and at other accelerator laboratories worldwide in the acceleration, accumulation, storage and phase space cooling of high-energy proton and heavy-ion beams. Based on that experience and adopting new developments, e.g. in fast cycling superconducting magnet design, in stochastic and in high-energy electron

cooling of ion beams, and also in ultra-high vacuum technology, a first conceptual layout of the new facility was proposed in 2001. Since then, the layout published in the Conceptual Design Report has undergone several modifications in order to accommodate additional scientific programs and optimize the layout, but also to reduce costs and to minimize the ecological impact of the project.

The present layout is shown in Fig. 2.1. A superconducting double-synchrotron SIS100/300 with a circumference of 1,100 meters and with magnetic rigidities of 100 and 300 Tm, respectively, is at the heart of the FAIR accelerator facility. Following an upgrade for high intensities, the existing GSI accelerators UNILAC and SIS18 will serve as an injector.

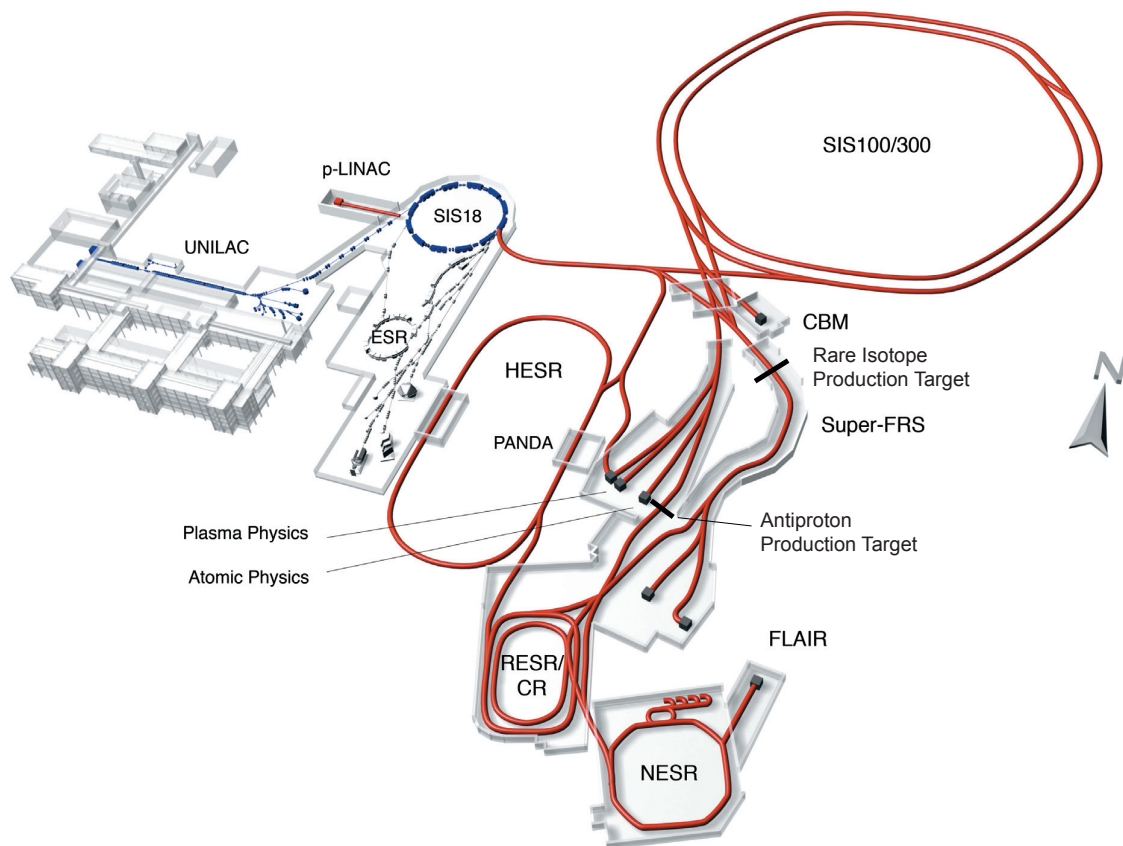

Figure 2.1: Layout of the existing GSI facility (UNILAC, SIS18, ESR) on the left and the planned FAIR facility on the right: the superconducting synchrotrons SIS100 and SIS300, the collector ring CR, the accumulator ring RESR, the new experimental storage ring NESR, the rare isotope production target, the superconducting fragment separator Super-FRS, the proton linac, the antiproton production target, and the high energy antiproton storage ring HESR. Also shown are the experimental stations for plasma physics, relativistic nuclear collisions (CBM), radioactive ion beams (Super-FRS), atomic physics, and low-energy antiproton and ion physics (FLAIR).

Adjacent to the large double-synchrotron is a complex system of storage-cooler rings and experiment stations, including a superconducting nuclear fragment separator (Super-FRS) and an antiproton production target. FAIR will supply rare isotope beams (RIBs) and antiproton beams with unprecedented intensity and quality. Moreover, the facility is designed to provide particle energies 20-fold higher compared to those achieved so far at GSI.

An important feature of the FAIR accelerator facility is that, due to the intrinsic cycle times of the accelerator and storage-cooler rings, up to four research programs can be run in a truly parallel mode. This allows, in a very efficient and cost-effective way, a rich and multidisciplinary research program, covering the fields: QCD studies with cooled beams of antiprotons, nucleus-nucleus collisions at highest baryon density, nuclear structure and nuclear astrophysics investigations with nuclei far off stability, high density plasma physics, atomic and material science studies, radio-biological and other application-oriented studies.

2.2 FAIR Performance Requirements and Basic Facility Concept

The concept and design of the FAIR accelerator facility were derived from the following requirements set by the planned scientific programs:

Beams of all ion species plus antiprotons: FAIR is expected to provide beams of all ion species, from hydrogen to uranium, as well as antiprotons over a large energy range (from particles at rest up to several tens of GeV/u energy in the laboratory frame).

Highest beam intensities: For primary beams, the intensity increase aimed for is a factor of up to several hundred for the heaviest ion species compared to present installations. For the production of radioactive secondary beams, and also for the generation of high-power pulses for plasma research, the high-intensity beams circulating in the SIS100-synchrotron are to be compressed to short bunches of 50 - 100 ns duration. The increase in primary intensity translates into an even higher gain factor, from 1,000 to 10,000, for secondary rare isotope beam intensities, due to the higher acceptances of the subsequent separators and storage rings.

Increase in beam energy: For antiproton production, intense proton beams are to be provided with energies around 30 GeV. In order to achieve highest baryon densities and enable charm production in high energy nucleus-nucleus collisions, the SIS300-synchrotron is designed for beam energies of up to 35 GeV/u for uranium 92^+ .

High-quality beams: Exploiting phase space cooling techniques, such as stochastic, electron, and also laser cooling, FAIR aims for providing high quality primary and secondary beams with momentum spread and emittance reduced by several orders of magnitude. Together with the statistical precision and high sensitivity that result from high beam intensities and interaction rates, these high-quality beams will allow novel precision experiments on the structure of matter and the underlying fundamental interactions and symmetries.

The following facility concept and layout for the accelerators were developed in order to comply with the aforementioned experimental requirements.

Synchrotrons and storage rings as accelerator structures of choice: Synchrotrons are the simplest and most cost-effective way to accelerate ion beams to high energies, from protons to uranium ions. Even more important, in view of the planned research program with FAIR, is the time structure of the primary beams given by the synchrotron acceleration, which allows an ideal adaptation to the subsequent storage rings.

Superconducting synchrotrons and acceleration of medium charge states: The high primary beam intensities will be achieved by fast cycling superconducting synchrotrons plus, for heavier ions, by acceleration of low charge-state ions. The charge-state enters quadratically into the space charge limit. The reduced charge-state, at the desired energy of up to 1.5 GeV/u for secondary radioactive ion beams, requires a larger bending power of the dipole magnets as compared to the present SIS18.

High bending power for higher particle energies: The high bending power of the SIS100 dipole magnets allows the acceleration of protons to about 30 GeV for an effective antiproton production. For the research program on nucleus-nucleus collisions at energies up to 35 GeV/u for uranium 92^+ , the second synchrotron ring SIS300 with a correspondingly higher bending power is needed. It is designed for long extraction periods and can also be used as a stretcher ring.

2.3 Technical Description of the FAIR Accelerator Facility

SIS100/300 double synchrotron

The experimental requirements concerning particle intensities and energies will be met by the SIS100/300 double synchrotron with a circumference of about 1,100 meters and with magnetic rigidities of 100 and 300 Tm, respectively. It constitutes the central part of the FAIR accelerator facility (see Fig. 2.1).

Table 2.1: Key parameters and features of the synchrotrons and cooler/storage rings

Ring	Circumference [m]	Beam rigidity [Tm]	Beam Energy	Features
Synchrotron SIS100	1084	100	2.7 GeV/u for U ²⁸⁺ 29 GeV for protons	Fast pulsed superferric magnets 4 T/s, up to 2 T, bunch compression to ~60 ns for 5·10 ¹¹ U ions, fast and slow extraction, 5·10 ⁻¹² mbar operating vacuum
Synchrotron SIS300	1084	300	34 GeV/u for U ⁹²⁺	Fast pulsed superconducting cosθ-magnets 1 T/s, up to 6 T slow extraction of ~3·10 ¹¹ U-ions per sec, 5·10 ⁻¹² mbar operating vacuum
Collector Ring CR	211	13	0.74 GeV/u for U ⁹²⁺ 3 GeV for antiprotons	Acceptance for antiprotons: 240 mm mrad: Δp/p=±3·10 ⁻² , fast stochastic cooling, isochronous mass spectrometer
Accumulator Ring RESR	245	13	0.74 GeV/u for U ⁹²⁺ 3 GeV for antiprotons	Accumulation of antiprotons (pre-cooling in the CR), fast deceleration of short-lived nuclei (1T/s)
New Experimental Storage Ring NESR	222	13	0.74 GeV/u for U ⁹²⁺ 3 GeV for antiprotons	Electron cooling of radioactive ions and antiprotons, precision mass spectrometer, internal targets with atoms and electrons, electron-nucleus scattering facility, deceleration of ions and antiprotons (1 T/s)
High-Energy Storage Ring HESR	574	50	14 GeV for antiprotons	Stochastic cooling of antiprotons up to 14 GeV, electron cooling of antiprotons up to 9 GeV; internal gas jet or pellet target

The two synchrotrons will be built on top of each other in a subterranean tunnel. They will be equipped with rapidly cycling superconducting magnets in order to minimize both construction and operating costs. For the highest intensities, the 100 Tm synchrotron will be operated at a repetition rate of 1 Hz, i.e. with ramp rates of up to 4 Tesla per second of the bending magnets. The goal of the SIS100 is to achieve intense pulsed (5·10¹¹ ions per pulse) uranium beams (charge state q = 28+) at 1 GeV/u and intense (4·10¹³) pulsed proton beams at 29 GeV. For the supply of high-intensity proton beams, which are required for antiproton production, a separate proton linac as injector to the SIS18 synchrotron will be constructed.

Both heavy-ion and proton beams can be compressed down to very short bunch lengths required for the production and subsequent storage and efficient cooling of exotic nuclei (~60 ns) and antiprotons (~25 ns). These short intense ion bunches are also needed for plasma physics experiments.

With the double ring facility, continuous beams with high average intensities of up to 3·10¹¹ ions per second will be provided at energies of 1 GeV/u for heavy ions, either directly from the SIS100 or by transfer to, and slow extraction from the 300 Tm ring. The SIS300 will provide high-energy ion beams of maximum energies around 45 GeV/u for Ne¹⁰⁺ beams and close to 35 GeV/u for fully stripped U⁹²⁺ beams. The maximum intensities in this mode are close to 1·10⁹ ions/s. These high-energy beams will be extracted over periods of 10 - 100 seconds in quasi-continuous mode, as the complex detector systems used for nucleus-nucleus collision experiments can accept up to 10⁸-10⁹ particles per second. Slow extraction from the SIS100 is an option for extending the flexibility of parallel operation for experiments.

Collector, Storage, and Cooler Rings

Coupled to the SIS100/300 double-ring synchrotron there is a complex system of storage rings - equipped with beam cooling facilities, internal targets, and in-ring experiments - which, together with the production

Table 2.2: Primary beam parameters from the SIS100/300 facility for the different research fields

Research Field	Energy	Peak Intensity	Average Intensity	Pulse Structure
Radioactive Ion Beams	0.4 to 1.5 GeV/u for all elements up to uranium	$\sim 5 \cdot 10^{11}$ per pulse for storage ring experiments	$\sim 3 \cdot 10^{11}$ per second high duty cycle for fixed target experiments	~ 60 ns for injection into the storage ring
Antiprotons	29 GeV protons	$4 \cdot 10^{13}$ per cycle	--	~ 25 ns
Dense Nuclear Matter	45 GeV/u for $A/q=0.5$ up to 34 for $A/q=2.7$	--	$2 \cdot 10^9$ per second	--
Plasma Physics	0.4 to 1 GeV/u ions	$\sim 10^{12}$ per pulse	--	50 - 100 ns (fixed target)
Atomic Physics	0.1 to 10 GeV/u ions	--	--	--

targets and separators for antiproton beams, secondary and radioactive ion beams, provides an unprecedented variety of particle beams at FAIR.

The additional storage rings are:

The Collector Ring (CR) for stochastic cooling of radioactive and antiproton beams. Moreover, the CR allows mass measurements of short-lived nuclei using the time-flight method in the isochronous operation mode.

The Accumulator Ring (RESR) for accumulation of antiproton beams after stochastic pre-cooling in the CR and also for fast deceleration of radioactive secondary beams with a ramp rate of up to 1 T/s.

The New Experimental Storage Ring (NESR) for experiments with exotic ions and with antiproton beams. The NESR is equipped with stochastic and electron cooling. Further instrumentation includes precision mass spectrometry using the Schottky frequency spectroscopy method, internal target experiments with atoms and electrons, an electron-nucleus scattering facility, and collinear laser spectroscopy. Moreover, the NESR serves to cool and to decelerate stable and radioactive ions as well as antiprotons for low energy experiments and trap experiments at the FLAIR facility.

The High-Energy Storage Ring (HESR) for antiproton beams at energies of 3 GeV up to a maximum energy of 14.5 GeV. The ring is equipped with electron cooling up to an energy of 8 GeV (5 MeV electron energy maximum) and for stochastic cooling up to 14.5 GeV. The experimental equipment includes an internal pellet target and the large in-ring detector PANDA as well as

an option for experiments with polarized antiproton beams.

Tables 2.1-2.3 provide more detailed information on the key parameters of the proposed double synchrotron, on the primary beam parameters that will be achieved with the SIS100/300 double synchrotron, and on the specific ways the various research programs will use the FAIR accelerator facility.

2.4 Modifications to the Conceptual Design Report

Compared to the preliminary facility layout presented in the original Conceptual Design Report, the present layout contains a number of modifications and improvements:

- Increase in the magnetic rigidity of the second synchrotron ring from 200 to 300 Tm (SIS200 SIS300) in order to increase the maximum energy to about 35 GeV/u for U^{92+} beams.
- Addition of a storage ring (RESR) to achieve the desired accumulation and cooling performance.
- Change of HESR injection and operating mode (as well as of its location). Injection of antiprotons will take place from the CR/RESR facility at particle energy of 3 GeV. The HESR will be equipped with accelerator structures for acceleration up to 14.5 GeV. Moreover, a proton beam line for commissioning and, as a future option, for injection of polarized proton beams into the HESR from the SIS18 has been added.
- Modifications to the injection and extraction positions of the synchrotrons.

Table 2.3: Usage of the accelerator and storage rings by the different research fields

Ring	Radioactive Ion Beams	Antiprotons	Dense Nuclear Matter	Plasma Physics	Atomic Physics
Synchrotron SIS100	$\sim 5 \cdot 10^{11}$ U ions per pulse, pulse compression to ~ 60 ns,	$\sim 4 \cdot 10^{13}$ protons per pulse, pulse compression to ~ 25 ns,	up to $2 \cdot 10^{11}$ ions per pulse, for injection to SIS300	$\sim 5 \cdot 10^{11}$ U ions per pulse, pulse compression to ~ 60 ns,	10^9 ions per second, high duty cycle
Synchrotron SIS300	$\sim 3 \cdot 10^{11}$ U ions per second, high duty cycle	-	$1 \cdot 10^9$ ions per second, high duty cycle, up to 34 GeV/u U	-	Laser spectroscopy
Collector Ring CR	fast stochastic cooling, isochronous mass spectrometer for short-lived nuclei	fast stochastic cooling, high acceptance	-	-	-
Accumulator Ring RESR	fast (1T/s) deceleration of short-lived nuclei	accumulation of antiprotons	-	-	-
New Experimental Storage Ring NESR	fast (1T/s) deceleration of short-lived nuclei, electron cooling, precision mass spectrometer, electron-nucleus scattering	fast (1T/s) deceleration of antiprotons	-	-	electron cooling, internal target, deceleration and extraction to FLAIR, SPARC
High-Energy Storage Ring HESR	-	0.8-14 GeV antiprotons	-	-	-

- Re-design of the high-energy beam transport systems and experimental stations to reduce costs

2.5 Parallel Operation and Synergy

An important consideration in the design of the facility was a high degree of a truly parallel operation of different research programs. Simple beam splitting and switching to different target locations is of course generally possible at any accelerator. But this does not increase the integrated luminosity. Truly parallel operation aims for providing maximum integrated beam time and luminosity for each of the different programs running in parallel. The proposed scheme of synchrotrons and storage rings, with their intrinsic cycle times for beam acceleration, accumulation, storage and cooling, respectively, has the

potential to optimize such a parallel and highly synergetic operation. This implies that the facility operates for the different programs like a dedicated facility. Figure 2.2 illustrates how parallel operation performs with a cooled and accumulated antiproton beam, in parallel to a fixed target experiment with radioactive beams or relativistic heavy-ion beams slowly extracted from the second synchrotron ring SIS300 and an additional beam for plasma physics.

2.6 Technological Challenges

The beam characteristics aimed for at the FAIR facility are challenging. In order to achieve them, new technological approaches are to be pursued. The most important aspects to be addressed are:

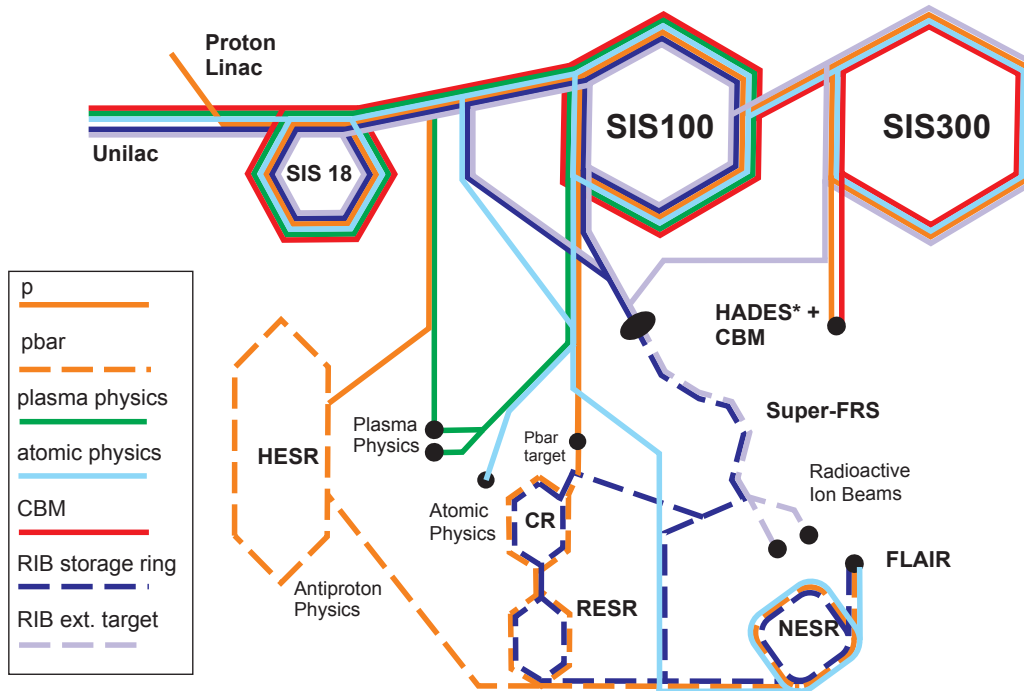

Figure 2.2: Schematic of parallel operation at the new facility. Up to four different scientific programs are served in parallel: A proton beam (orange), accelerated in SIS100, produces antiprotons (orange dashed) in the antiproton target-station, which are then collected, accumulated and cooled in the CR/RESR storage-ring combination, and transferred either to the HESR or to the NESR for experiments. In parallel, i.e. during the fraction of the SIS100 super-cycle not needed for the protons, a primary ion beam is accelerated in SIS100 and slowly extracted to the Super-FRS to produce radioactive secondary beams for fixed target experiments (violet-dashed) or for storage in the CR and NESR instead of antiprotons (blue-dashed). In addition, every 10-100 seconds a high-energy heavy-ion beam (red) is accelerated in SIS100/300 and slowly extracted for nuclear collision experiments. Moreover, intense compressed beam pulses (green) are provided every few minutes for plasma physics experiments that require very low repetition rates. Alternatively, atomic physics experiments (light blue) may be served by SIS100 in the pauses of the antiproton production.

Control of the dynamic vacuum pressure. Beam-loss induced desorption of heavy molecules can cause the rapid increase of the residual gas pressure. In order to maintain the ultra-high vacuum conditions needed for operation with partly stripped heavy ions, a novel collimation concept has been developed which is presently being tested at the SIS18.

Operation with high brightness, high current beams. The synchrotrons will operate close to the space charge limits with tolerable beam losses in the order of a few percent. The control of collective instabilities and the reduction of the ring impedances is a subject of the present R&D phase.

High rf voltage gradients. Fast acceleration and compression of the intense heavy-ion beams require compact rf systems. Complex rf manipulations with minimum phase space dilution and the reduction of the total beam loading in the rf systems are important R&D issues.

Fast cycling superconducting magnets. For SIS100, super-conducting magnets with 2 T maximum field

and with 4 T/s ramping rate are required. SIS300 will be equipped with 6 T (1 T/s) dipole magnets. The optimization of the magnet field quality for low loss, high current operation with beams filling large parts of the acceptance is therefore of great importance and an issue of intense R&D.

Cooled secondary beams. Fast electron and stochastic cooling at medium and at high energies will be essential for experiments with exotic ions and with antiprotons. In order to achieve the required luminosities in the antiproton storage ring HESR, magnetized electron cooling at high energies (5 MeV) will be necessary, which represents a step beyond the only existing high energy electron cooler at Fermilab.

In the last five years, substantial R&D work has been dedicated to the aforementioned technological aspects. Considerable progress has been achieved and the principal feasibility of the proposed technical approaches has been demonstrated. Prototyping of certain components has started. For details see Volume 2.

3. Experimental Programs and Collaborations

3.1 Overview

In general terms, the research goals and scientific objectives of the science at FAIR can be grouped into 3 major areas: i) a deeper understanding of the structure and properties of matter; this includes a reduction of the structure of matter to the basic building blocks and fundamental laws, forces and symmetries; and an understanding how complexity arises from these fundamental constituents, a complexity which does not come from a simple linear superposition but involves non-linear processes, correlations and coherences; ii) contributions to our knowledge about the evolution of the Universe; the hierarchical structure of matter, from the microscopic to the macroscopic, is directly related to the sequence of steps in the evolution and generation of the visible world; iii) use of ion beams in technology and applied research

These general research goals can be grouped into the following specific fields of research at FAIR:

- Nuclear structure and nuclear astrophysics with beams of stable, but in particular also of short-lived (radioactive) nuclei far from stability;
- Hadron structure, the theory of the strong interaction quantum chromo-dynamics (QCD), and the QCD vacuum, primarily with beams of antiprotons;

- The nuclear matter phase diagram and the quark-gluon plasma with beams of high-energy heavy ions;
- Physics of very dense plasmas with highly compressed heavy-ion beam bunches in unique combination with a petawatt laser currently under construction;
- Atomic physics, quantum electro-dynamics (QED) and ultra-high electro-magnetic fields with beams of highly-charged heavy ions and antimatter;
- Technical developments and applied research with ion beams for materials science and biology.

The respective experiment proposals and collaborations are listed in Table 3.1. The table also indicates the major experimental apparatus involved in the respective research programs.

Each individual experiment has been thoroughly reviewed by an international Program Advisory Committee (PAC). The experiments that have been included in the core facility were selected on basis of scientific merit, discovery potential and technical feasibility. Possible extension to the baseline research program have also been included.

Table 3.1 lists the 18 individual research programs approved for FAIR with a brief characterization of the science goals and the associated scientific instrumentation (It also lists a few future options evaluated by the program committees but not yet part of the base program and the core (baseline) facility. The different research programs are grouped into 3 major scientific areas: nuclear structure, astrophysics and reactions (NUSTAR), quantum chromodynamics and hadron physics (QCD) and atomic physics, plasma physics and applications (APPA).

Experiment	Scientific Area	Research Program	Technical Facility	Members	Institutes	Countries	Core Facility
R3B	NUSTAR	Nuclear reactions in inverse kinematics reaction studies with relativistic radioactive ion beams	Large reaction set-up allowing complete kinematics reaction experiments	178	54	19	yes
HISPEC/DESPEC	NUSTAR	High resolution, high efficiency particle and gamma spectroscopy of nuclei far off stability	State-of-the-art γ detectors (AGATA) plus set-ups for charged particle and neutron detection	89 / 62	52 / 34	22 / 17	yes
LASPEC	NUSTAR	Laser spectroscopy of radioactive ion species	Multi-purpose laser spectroscopy station	33	15	8	yes
MATS	NUSTAR	High precision, high efficiency mass and lifetime measurements on radioactive nuclei	Combined set-up of an electron beam ion trap (for charge breeding), ion traps (for beam preparation) and a precision Penning trap system.	64	22	9	yes
ILIMA	NUSTAR	Mass and lifetime measurements of stored and cooled radioactive ion beams	Devices for Schottky mass and isochronous mass spectroscopy at CR/NESR	73	23	11	yes
EXL	NUSTAR	Inverse kinematics light ion reactions on radioactive nuclei	In-ring reaction set-up to be installed at the NESR	134	39	15	yes
AIC	NUSTAR	Measurements of mass radii of nuclei far off stability	Antiproton (radioactive) ion collider	25	8	5	no
ELISE	NUSTAR	Measurements of elastic, inelastic and quasi-free electron scattering of nuclei far off stability	Electron-ion collision device including a high resolution electron spectrometer at the NESR	96	29	9	yes
NCAP	NUSTAR	Production of specific radio-nuclides for (off-site) neutron capture studies	None	20	14	6	no
EXO-pbar	NUSTAR	Measurements of proton-neutron abundance at the nuclear surface of nuclei far off stability	Reaction experiment of very low-energy radioactive ions with antiprotons stored in a Penning trap	20	5	5	no

PANDA	QCD	QCD and hadron physics studies with cooled high energy antiproton beams at the HESR	Large state-of-the-art internal target detector system covering almost the full solid angle	344	70	13	yes
CBM	QCD	Studies of the QCD phase diagram in high-energy nucleus-nucleus collisions	Large state-of-the-art fixed target detector system covering almost the full solid angle	357	63	15	yes
PAX/ ASSIA	QCD	QCD and hadron physics studies with polarized antiproton beams	State-of-the-art collider detector system covering a large solid angle	170/ 85	33 / 12	11 / 5	no
HEDGE- HOB/ WDM	APPA	Investigations of warm and dense bulk matter produced by intense ion and/or laser pulses	Various plasma physics experimental stations	162 / 55	50 / 19	13 / 6	yes
FLAIR	APPA	(Precision) studies with low energy or stopped antiproton ion beams	Various stations including an ultra-low energy electrostatic storage ring, a Penning trap, low energy antiproton target stations	142	54	17	yes
SPARC	APPA	Atomic physics spectroscopy and collision studies with (stored) high energy ion beams	Various fixed target and in-ring experiments	218	108	28	yes
BIOMAT	APPA	Applications of ion and antiproton beams in biophysics, biology, materials research and other disciplines	Various multi-purpose target stations	49	28	10	yes

3.2 Nuclear Structure, Astrophysics and Reactions with Rare-Isotope-Beams - the NUSTAR Collaborations

FAIR will provide intense secondary beams of unstable isotopes across the entire nuclide chart. Beam intensities exceed those available at existing rare-isotope-beam facilities by several orders of magnitude and beam energies are variable up to more than 1 GeV/u. A superconducting in-flight separator (Super-FRS) serves external stations and coupled storage-cooler rings including an electron-ion collider. The novel instruments and experimental opportunities have attracted a large community of nuclear physicists addressing a broad research spectrum covering nuclear structure physics, nuclear astrophysics, and studies of fundamental interactions and symmetries. Proposals for experiments at the FAIR Rare-Isotope-Beam facility were presented by international collaborations, organized in the broader umbrella collaboration NUSTAR (Nuclear Structure, Astrophysics, and Reactions) with more than 700 members in total. Altogether 9 experimental programs are presently planned at the three branches of the Super-FRS. In the following, a brief overview will be given on the planned programs and experiments; for a detailed description we refer to Volume 4 of this Baseline Technical Report.

3.2.1 Physics Case

The atomic nucleus has proven to be an exceedingly interesting many-body system that has come up with surprises over and over again. The building blocks are protons and neutrons, both spin 1/2 particles, which are themselves complex many-body structures composed of quarks and gluons. The Quantum Chromo Dynamical (QCD) degrees of freedom are, however, not excited in low energy explorations of the nucleus. The underlying QCD-structure rather manifests itself in a complex nucleon-nucleon force with spin- and isospin-dependent terms. A strong short-range repulsion is balanced by long-range attractive interactions including also spin-orbit and tensor forces. A strongly correlated self-bound quantum system, the nucleus is thus formed that exhibits a wide spectrum of phenomena.

Exciting new aspects of nuclear structure are coming from the study of exotic short lived nuclei by means of secondary beams of radioactive nuclei. Much of what we know about nuclei comes from nuclear reactions. In the past, these were limited to stable nuclei, available as target materials, in bombardments with beams of (other) stable nuclei, in particular light nuclei. Having short-lived nuclei available as energetic beams, now allows to extend such studies in an inverse laboratory kinematics to unstable radioactive nuclei away from stability. Exotic nuclei are characterized by an extreme excess of protons or neutrons and are thus located far away from

the valley of stability. New structural phenomena are to be expected, such as very different proton and neutron density distributions with proton/neutron skins or halos, or such as new excitation modes that are not observed in stable nuclei. A study of such effects is of paramount interest for a complete understanding of the isospin and density dependence of the effective in-medium forces and of pairing and clusterization phenomena. With increasing isospin, the Fermi surface of the excess nucleons moves towards the continuum threshold, the sectors of bound and unbound states are not separated anymore to the extent as in stable nuclei. Correlations resulting from substantially differing Fermi edges and the appearance of weakly bound single-particle levels lead, in consequence, to new magic numbers.

Evidently, only by synergy of theory and experiment, the new challenges in nuclear structure physics can successfully be approached. The bulk of nuclear structure models employs effective interactions whose parameters have been adjusted to known nuclear data, basically to that for stable nuclei. The study of nuclei far away from stability at FAIR will provide additional data on the nuclear many-body system under extreme conditions which should be understood in a consistent and microscopic framework. The ultimate goal is to find a unified description of nuclei and their properties based on the principles of low-energy QCD and the fundamental interactions between nucleons.

Reactions between nuclei play a decisive role in many astrophysical processes in the Universe. Nuclear structure effects and the dynamics of nuclear reactions are directly reflected in the various evolutionary stages of stars, in the light curves of stellar explosions, and in the elemental abundance distributions in the Universe. Current key questions in nuclear astrophysics are: the origin of the chemical elements, the physics of stellar explosions, the different nuclear and mixing processes in stars, the understanding of compact objects like white dwarfs and neutron stars and the thermonuclear explosions on their surfaces, which are observed as novae or x-ray bursts. Unstable nuclei, far away from stability, are involved and their properties determine the fate of the relevant astrophysical processes.

At the FAIR facility it will be possible for the first time to experimentally determine the properties of many of these unstable nuclei. FAIR will, in particular, deliver decisive contributions to the understanding of the origin of the heavy elements, of core-collapse (type II) and thermonuclear (type Ia) supernovae, of the physics of compact objects and the explosions on their surfaces (novae,

x-ray bursts). Simultaneously, the next generation of astronomical observatories, as well as refined analysis of star dust from meteorites, will produce a wide range of data of unprecedented quality about the elemental abundance distribution and stellar explosions. Supplemented by advances in nuclear theory and theoretical astrophysics these novel nuclear and astronomical data will result in a unified picture of the processes in the Universe, which are responsible for our existence.

3.2.2 The Rare-Isotope-Beam Facility at FAIR

Studies with Rare Isotope Beams (RIB) form one of the major research programs at FAIR. The radioactive beam facility at FAIR offers world-wide unique experimental opportunities for this area of research. The secondary beams of unstable nuclei are produced by fragmentation of a primary heavy-ion beam or by fission of an ^{238}U beam at energies up to 1.5 GeV/u, followed by in-flight separation in a partially superconducting magnetic separator (Super-FRS).

The facility at FAIR surpasses in many respects the capabilities of that of existing RIB facilities and competes with corresponding projects in Japan and USA in particular by innovative experimental concepts through instrumentation not available elsewhere.

The FAIR synchrotrons, operated in a high-intensity modus (primary beam intensities of several 10^{11} ions per second), together with the extraordinary phase-space acceptance of the in-flight fragment separator (Super-FRS) yields secondary beam intensities with several orders of magnitude higher than available presently. Since the production process is chemically not selective and since the transport time is negligible, isotopes even of shortest lifetimes can be provided and be studied. Secondary beams are delivered with high purity in a wide range of beam energies and with variable (pulsed or quasi-dc) time structure and are eventually delivered to the target stations or are injected into storage rings.

The Super-FRS has to efficiently separate in-flight rare isotopes produced via projectile fragmentation of all primary beams up to ^{238}U and via fission of ^{238}U beams. The latter reaction is a prolific source of very neutron-rich nuclei of medium mass. However, due to the relatively large amount of kinetic energy released in the fission reaction, the products populate a large phase space and thus demands for an extraordinary acceptance. Compared to the in-flight fragment separator (FRS) existing presently at GSI, more than one order of magnitude is gained in transmission of fission products due the increased momentum and angular acceptance.

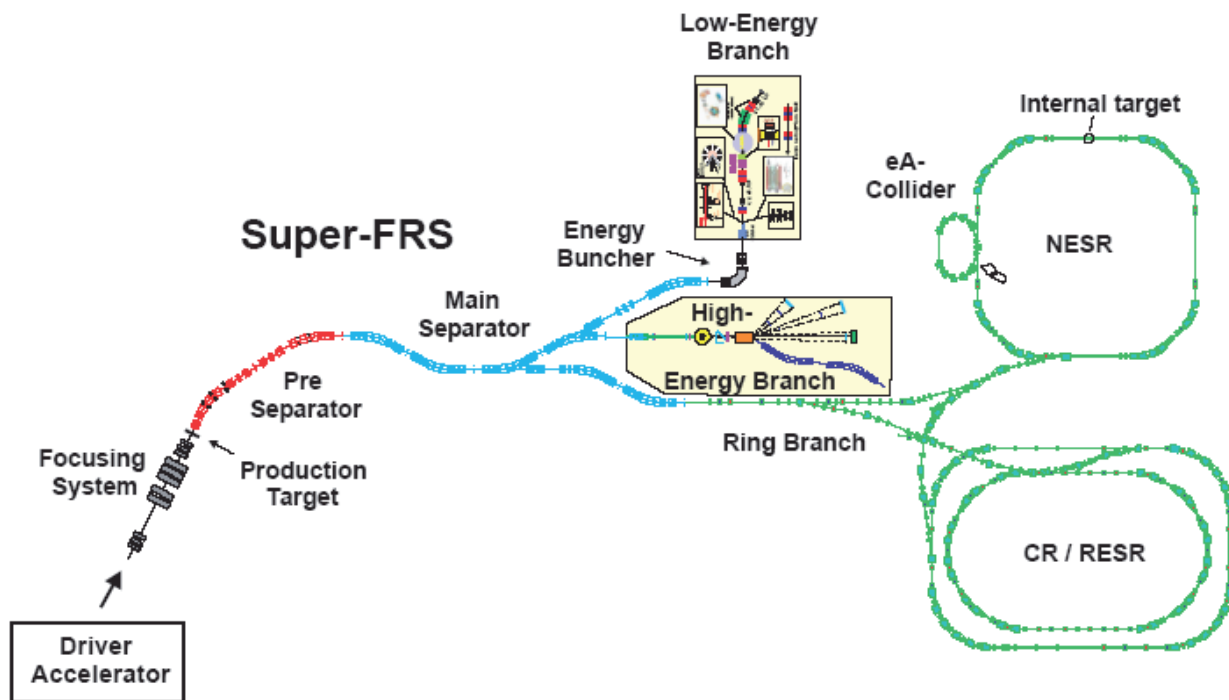

Figure 3.1: Schematic view of the rare-isotope-beam facility at FAIR with the superconducting in-flight separator (Super-FRS) and its three experimental branches: the high-energy reaction area, the low-energy area, and the storage ring complex (CR-RESR-NESR) with the intersecting electron collider (eA).

Besides fragment intensities, selectivity and sensitivity are the crucial parameters that strongly influence the success of an experiment with very rare nuclei. A prerequisite for a clean isotopic separation is that the fragments have to be fully ionized to avoid cross contamination from different ionic charge states. Multiple separation stages are necessary to efficiently reduce the background from such contaminants. Based on the experience of successful spatial isotopic separation with the existing FRS at GSI, the Super-FRS also uses the B ρ - ΔE -B ρ method, where a two-fold magnetic rigidity analysis is applied in front of and behind a specially shaped energy degrader. The high primary beam intensities expected from the SIS100/300 synchrotrons require additional measures to achieve the aimed for separation quality. A straight forward consequence is that the Super-FRS consists of a two-stage magnetic system, the pre- and the main-separator, both equipped with a degrader.

The demand for fully stripped fragments requires operation in the high-energy domain. On the other hand, the thicknesses of production target and degraders have to be optimized to prevent substantial losses due to secondary nuclear reactions. The above physics criteria as well as optimization of the performance and cost considerations have led to the choice of 20 Tm as maximum magnetic rigidity of the Super-FRS.

3.2.3 Experiments at the Rare-Isotope-Beam Facility

The secondary rare isotope beams produced and separated at the Super-FRS can be delivered to three experimental branches allowing for a diverse and highly flexible program at particle energies from rest up to 1 GeV/u. These branches are:

The high-energy branch

At the high-energy branch, an experimental area has been foreseen for high-energy reaction studies in inverse kinematics employing an apparatus of highest efficiency and full solid-angle coverage. For this, the R³B collaboration has designed an experimental set-up capable of fully benefiting from the Super-FRS beams with the characteristics inherent to the in-flight production method. Located at the focal plane of the high-energy branch of the Super-FRS, R³B is a versatile fixed-target detector with high efficiency, acceptance, and resolution for kinematically complete measurements of reactions with high-energy radioactive beams, even at very low beam intensities down to one ion per second. Such complete kinematics measurements were in the past very successful in discoveries of new structural phenomena, e.g. of halo structures, new collective modes, or of new shell closures. Mainly for intensity reasons, the experiments were restricted to light-mass

nuclei, at FAIR they can be extended to heavy nuclei far off stability.

The research program planned by the R³B collaboration covers a wide variety of scattering experiments, i.e., such as heavy-ion induced electromagnetic excitation, knockout and breakup reactions, or light-ion (in)elastic and quasi-free scattering in inverse kinematics. Capture rates derived from Coulomb dissociation and Gamow-Teller strength distributions derived from charge-exchange reactions are of prime astrophysics interest.

The low-energy branch

At the Low-Energy Branch, it will be possible to study properties and phenomena of exotic nuclei employing mono-energetic low-energy beams from the Super-FRS (energies ranging from about 100 MeV/u down to a few MeV/u, stopped beams, and re-accelerated beams of a few tens of keV). An ‘energy-buncher’ allows for a partial compensation of the beam energy spread induced by the passive slowing-down process. Four collaborations (HISPEC/DESPEC, LASPEC, MATS, NCAP) proposed experiments at the low-energy branch.

HISPEC/DESPEC deals with a versatile, high-resolution, high-efficiency spectroscopy set-up to address questions in nuclear structure, reactions and astrophysics using radioactive beams with energies of 3-150 MeV/u (HISPEC) or stopped and implanted beam species (DESPEC). In-beam γ -ray and particle spectroscopy after (multiple) Coulomb excitation and other reactions in the low to intermediate energy regime are performed using the AGATA Ge array and charged particle detectors. Decay spectroscopy (β -decay, isomer decay, exotic decays) after stopping and implantation of the fragment beams in a silicon detector stack surrounded by modular γ -ray and neutron arrays or by a total-absorption spectrometer is the subject of DESPEC.

The LASPEC collaboration proposes a multi-purpose laser spectroscopy station for the study of stopped, cooled and bunched radioactive species. It will permit, by a variety of optical techniques, the model-independent determination of isotopic and isomeric nuclear spins, magnetic dipole moments, electric quadrupole moments and changes in mean square charge radii. A variety of fluorescence, resonance ionization and polarization based spectroscopic techniques will be applied.

The MATS collaboration proposes measurements of high accuracy and high sensitivity suitable to very short-lived radionuclides. Two techniques are applied, high-precision mass measurements and in-trap conversion electron and alpha spectroscopy. The experimental setup of MATS combines an electron beam ion trap for charge

breeding, ion traps for beam preparation, and a high precision Penning trap system for mass measurements and decay studies.

The NCAP collaboration is interested in the production of specific radio-nuclids for off-site neutron-capture studies providing input needed in stellar models.

The ring branch.

Presently, GSI is the only research center worldwide hosting a facility (FRS-ESR) which allows accumulating radioactive beams in a storage-cooler ring. This invoked new experimental techniques, e.g. for mass measurements or in observing exotic decay modes. The storage ring concept will be further developed at FAIR by a multi-storage-ring system (CR-RESR-NESR) linked to the Super-FRS.

The coupled storage rings offer a high collection efficiency for secondary beams, and electron cooling combined with stochastic pre-cooling results in high-quality (with regard to emittance and momentum spread) beams within cooling periods of below one second. High luminosities can be achieved in consequence and allows for the first time for in-ring reaction experiments. Hadronic scattering experiments at low momentum transfer with high sensitivity to transition multipolarity and spin-isospin selectivity are of prime interest. Moreover an electron-ion collider ring will be coupled to the ion storage ring NESR allowing studies of unstable nuclei by a purely electromagnetic probe. Storage of antiprotons in the collider ring and studying antiproton-ion collisions is a further option being considered.

Four collaborations (ILIMA, EXL, ELISe and AIC) proposed experiments at the ring branch. All proposals take advantage of the unique capabilities offered by the multi-storage/collider ring system at FAIR. In particular they benefit from the much improved beam quality due to stochastic and electron cooling.

The ILIMA experimental program concerns mass and lifetime measurements of stored bare and highly charged nuclides as well as the access to pure isomeric beams. Such measurements are relevant both, for nuclear structure and astrophysics. The ILIMA concept

builds on the very successful methods of ‘Schottky Mass Spectrometry’ and ‘Isochronous Mass Spectrometry’, both pioneered at the ESR storage-cooler ring at GSI. The sensitivity of the two methods can substantially be improved at the CR and NESR rings, respectively, at FAIR.

The objective of the EXL collaboration is to capitalize on light-ion induced direct reactions at intermediate energies in inverse kinematics at an internal target in the NESR storage ring. Elastic and inelastic scattering, charge-exchange reactions, quasi-free scattering and transfer reactions can be studied with a universal detector setup. Due to their spin-isospin selectivity, light-ion induced direct reactions at intermediate to high energies are an indispensable tool in nuclear structure studies as evident from investigations of stable nuclei in the past. Such experiments enable for example precise measurements of mass distributions, of single-particle spectral functions, or of the electric and magnetic multipole response. Because of the kinematical conditions of inverse kinematics in case of beams of unstable nuclei, low-momentum transfer measurements, as envisaged, turn out to be an exclusive domain of storage ring experiments.

The ELISe proposal aims at elastic, inelastic, and quasi-free electron scattering by using intersecting ion and electron storage rings and an electron spectrometer with high resolution and large solid angle coverage complementing the EXL detector measuring the strong interaction radius. Both experiments together can discover neutron or proton halo in nuclei. The experiment will be installed at the New Experimental Storage Ring (NESR) where cooled secondary beams of radioactive ions collide with an intense electron beam circulating in a small electron storage ring.

The Antiproton-Ion Collider (AIC) collaboration proposed a collider experiment to measure rms-radii for protons and neutrons in stable and short lived nuclei by means of antiproton absorption at medium energies. The experiment makes use of the electron-ion collider (see above) with appropriate modifications of the electron ring in order to store, cool and collide antiprotons of 30 MeV energy with 740 MeV/u ions in the NESR.

3.3 Hadron Physics with Antiproton Beams - the $\bar{\text{PANDA}}$ Collaboration

The $\bar{\text{PANDA}}$ collaboration proposes to study fundamental questions of hadron and nuclear physics in interactions of antiprotons with nucleons and nuclei, using the universal $\bar{\text{PANDA}}$ detector. Gluonic excitations and the physics of strange and charm quarks will be accessible with unprecedented accuracy thereby allowing high-precision tests of the strong interaction. The proposed $\bar{\text{PANDA}}$ detector is a state-of-the-art internal target detector at the HESR at FAIR covering almost the full solid angle.

3.3.1 Physics Motivation

The strong force governs the microscopic structure of matter. It dominates the interaction between the nucleons, i.e. the protons and neutrons within the atomic nucleus, and it is the key force that determines the interaction between the quarks within the nucleon and within other hadrons (strongly interacting particles). Achieving a fully quantitative understanding of matter at this level is one of the challenging and fascinating areas of modern physics. During the last two decades hadronic physics has moved from phenomenological to a more fundamental understanding. The theory of Quantum Chromodynamics (QCD) is regarded as the basic theory of the strong interaction. While being elegant and deceptively simple, the theory generates a most remarkable richness and complexity of phenomena. The possible forms of matter range from the spectrum of strongly interacting hadrons and nuclear species to compact stars of extreme density and to the quark-gluon plasma, a state of matter in the early universe and, possibly, in the interior of very heavy stars.

The fundamental building blocks of QCD are the quarks which interact with each other by exchanging particles, the gluons. QCD is simple and well understood at short-distance scales, much shorter than the size of a nucleon ($< 10^{-15}$ m). In this regime, the basic quark-gluon interaction is sufficiently weak. Here, perturbation theory can be applied, a calculation technique of high predictive power yielding accurate results when the coupling strength is small. In fact, many processes at high energies can quantitatively be described by perturbative QCD within this approximation.

The perturbative approach fails when the distance among quarks becomes comparable to the size of the nucleon, the characteristic dimension of our microscopic world. Under these conditions, the force among the quarks becomes so strong that they cannot be further separated, in contrast to the electromagnetic and gravitational forces which fall off with increasing distance. This unusual behavior is related to the self-interaction of gluons: gluons do not only interact with quarks but also

with each other, leading to the formation of gluonic flux tubes connecting the quarks. As a consequence, quarks have never been observed as free particles and are confined within hadrons, complex particles made of 3 quarks (baryons) or a quark-antiquark pair (mesons). Baryons and mesons are the relevant degrees of freedom in our environment. An important consequence of the gluon self-interaction and — if found — a strong proof of our understanding of hadronic matter is the predicted existence of hadronic systems consisting only of gluons (glueballs) or bound systems of quark-antiquark pairs and gluons (hybrids).

In the evolution of the universe, some microseconds after the big bang, a coalescence of quarks to hadrons occurred associated with the generation of mass. The elementary light quarks, the up and down quarks, that make up the nucleon have very small masses amounting to only a few percent of the total mass of the nucleon. Most of the nucleon mass, and of the visible universe stems from the QCD interaction. The generation of mass is associated with the confinement of quarks and the spontaneous breaking of chiral symmetry, one of the fundamental symmetries of QCD in the limit of massless quarks.

The phenomena of the confinement of quarks, the existence of glueballs and hybrids, and the origin of the mass of strongly interacting, composite systems related to confinement and the breaking of chiral symmetry are long-standing puzzles and represent the intellectual challenge in our attempt to understand the nature of the strong interaction and of hadronic matter. GSI has a distinguished history of having made important contributions to the physics of strong interactions, in particular nuclear physics. The proposed $\bar{\text{PANDA}}$ experiment will enable the new FAIR facility to play a significant role in strong interaction physics, providing a link between nuclear physics and hadron physics.

3.3.2 Research Program

The proposal demonstrates that antiproton beams of unprecedented intensity and quality in the energy range of 1 GeV to 15 GeV, as provided by the new FAIR facility together with $\bar{\text{PANDA}}$, will be an excellent tool to address fundamental questions. Antiproton beams in this energy regime, stored in the High-Energy Storage Ring (HESR) for in-ring experiments, will provide access to the heavier strange and charm quarks and to copious production of gluons. As illustrated in Figure 3.2, the physics program offers a broad range of investigations that extend from the study of Quantum Chromodynamics to the test of fundamental symmetries.

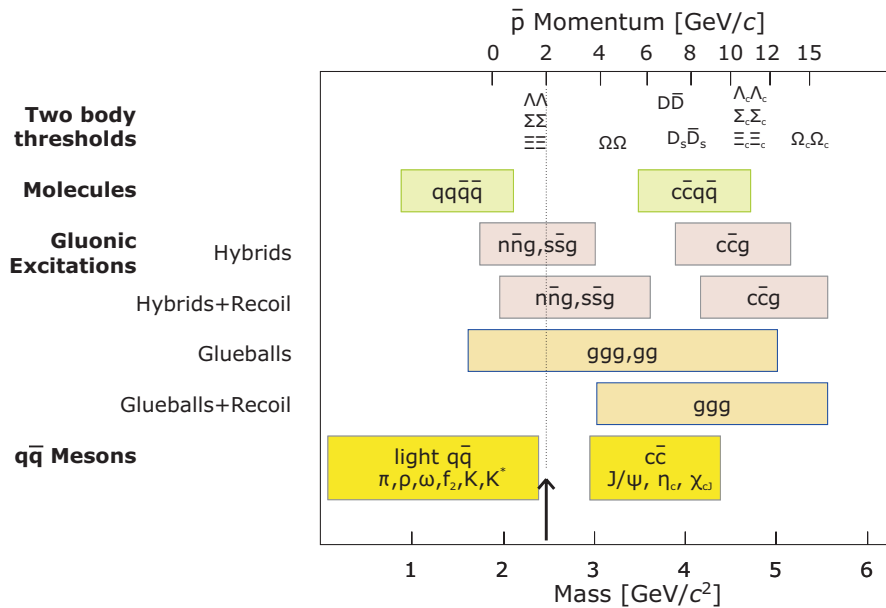

Figure 3.2: Mass range of hadrons accessible at the HESR with antiproton beams. The figure indicates the antiproton momenta required for charmonium spectroscopy, the search for charmed hybrids and glueballs, the production of D meson pairs and the production of Σ baryon pairs for hypernuclear studies. The energy range covered by the former Low Energy Antiproton Ring (LEAR) at CERN is indicated by the arrow.

The key components of the antiproton program are summarized as follows:

The determination of the interaction potential through precision spectroscopy has been a successful tool at all levels of the structural hierarchy of matter, as for example in atoms and molecules. The charm quark is sufficiently heavy to lend itself to non-relativistic perturbative treatment far more reliably than the light up, down, and strange quarks. Thus, an optimal testing ground for a quantitative understanding of confinement is provided by charmonium spectroscopy, i.e. the spectroscopy of mesons built of charmed quark-antiquark pairs ($c\bar{c}$). Recently, completely unexpected and surprising results in form of the discovery of new states in the charmonium mass region show that this field is far from being understood experimentally and theoretically.

The proposed program, using resonant antiproton-proton annihilation, is a quantitative and qualitative extension of successful experiments performed at the antiproton accumulator at FNAL, USA. However, those experiments which ended in the year 2000 were limited in scope by lower antiproton energies (< 9 GeV), lower luminosities ($\leq 2.5 \cdot 10^{31} \text{ cm}^{-2}\text{s}^{-1}$) and a detector only capable of detecting electromagnetic reaction products. At FAIR, advanced antiproton cooling techniques will enable high energy resolution and a more versatile detector setup will be employed allowing for the first time a measurement of both electromagnetic and hadronic decay modes with high precision. The goal is to achieve comprehensive precision spectroscopy of the

charmonium system for a detailed study, particularly of the confinement part of the QCD potential. This in turn will help to understand the key aspects of gluon dynamics which are being investigated and quantitatively predicted in the framework of Lattice QCD.

Previous experiments at LEAR/CERN have demonstrated that particles with gluonic degrees of freedom are produced copiously in proton-antiproton annihilation in the light quark sector. A central part of the antiproton program presented in this proposal is the first search for gluonic excitations, glueball and hybrids, in the charmonium mass range where they are expected to be less mixed with the multitude of normal mesons. The unambiguous determination of the gluonic modes would establish an important missing link in the confinement problem of hadrons.

GSI has an active ongoing program on the modification of the properties (masses, widths, etc) of light mesons (pions and kaons) by the nuclear medium and the relation to the partial restoration of chiral symmetry. The proposed experimental program at the HESR will address the open problem of interactions and in-medium modifications of hadrons with charm quarks in nuclei. Additionally, the program will provide the first insight into the gluonic charmonium-nucleon and charmonium-nucleus interaction. A quantitative knowledge of charmonium-nucleon cross sections is considered to be of crucial importance in the identification of the formation of the quark-gluon plasma in ultra-relativistic heavy-ion collisions.

A new and largely unexplored dimension in the chart of nuclides is introduced by replacing an up or down quark by a strange quark in a nucleon bound in a nucleus, leading to the formation of a hypernucleus. Here, the strangeness quantum number is introduced into the nucleus. Antiproton beams at the proposed facility will allow efficient production of hypernuclei with more than one strange hadron. The program opens new perspectives for nuclear structure studies and is a novel complement to the proposal to study the structure of nuclei with radioactive beams. The nucleon with the strange quark (hyperon) is not restricted in the population of nuclear states as neutrons and protons are. These exotic nuclei offer a variety of new and exciting perspectives in nuclear spectroscopy and for studying the forces among hyperons and nucleons.

One of the most important symmetries of physics is CP symmetry (charge conjugation C times spatial parity P). CP symmetry implies that the laws of physics apply to a system after the combined action of exchanging particles by their antiparticles and by reflection of the system in a spatial mirror. However, if CP symmetry was perfectly obeyed, none of the matter in the universe, neither stars nor human beings, would exist since matter and antimatter would have annihilated each other. The observed dominance of matter in the universe may be attributed to CP violation, an effect directly observed in the decay of neutral kaons and, very recently, in B mesons. CP violation can be studied in the charm meson sector and in hyperon decays, with the HESR storage ring running at full luminosity. An observation of significant CP violation would indicate physics beyond the Standard Model.

Two of the research areas with antiprotons, the in-medium properties of charmed hadrons and the structure of atomic nuclei with one or more strange hadrons, are examples of the close intellectual connection between the physics with antiprotons and two other major thrusts of the FAIR proposal, relativistic nucleus-nucleus collisions and nuclear structure physics with radioactive beams. They contribute in a synergetic way to the broader goal of a deeper understanding of the structure of hadronic matter in all its forms. Finally, the close connection between the various components of the present proposal is evident in the pursuit of symmetry tests and symmetry breaking effects, which are the key for our understanding of how the world is built from the fundamental building blocks.

3.3.3 Instrumentation and Detector

The technical capabilities and the uniqueness of the proposed facility are of great importance in the realization of the research objectives. Therefore the accelerator, and in particular the beam properties of the

HESR, have to be matched to the $\bar{\text{P}}\text{ANDA}$ detector. Beam cooling techniques are mandatory to deliver the beams of unprecedented quality and precision to the internal target facility with an advanced detector system.

The $\bar{\text{P}}\text{ANDA}$ detector design incorporates the most recent technologies in order to reach the required performance criteria with regard to mass, momentum and energy resolution, hit resolution, particle identification, and solid angle coverage. The combination of the high-quality antiproton beam and the detector system provides a powerful and unique facility, unparalleled worldwide, to carry out the research discussed in the main section of the report.

One important goal is to achieve almost full hermiticity. The detector has to be able to track particles down to momenta of 100-200 MeV/c and up to a maximum of 8 GeV/c. A vertex detector is required since many channels include charm mesons. A key component is electromagnetic calorimetry with excellent resolution. Furthermore, particle identification of kaons, protons, and muons is mandatory.

The general layout of $\bar{\text{P}}\text{ANDA}$ is based on two magnetic spectrometers and is shown in Figure 3.3. The target spectrometer surrounds the interaction region and has a superconducting solenoid as momentum analyzer. A forward opening of 5-10° (depending on the respective axis) allows high momentum tracks to enter the forward spectrometer with a large gap dipole magnet.

3.3.4 Interaction Region

Various targets are considered for the different physics programs within $\bar{\text{P}}\text{ANDA}$. Most of the measurements require a proton target which can be realized in two alternative ways:

- A pellet target device produces a stream of small pellets of frozen hydrogen falling through and interacting with the antiproton beam. This type of target is able to achieve average densities in the order of up to $10^{16} \text{ cm}^{-2}\text{s}^{-1}$. That would match the desired luminosity of $2 \cdot 10^{32} \text{ cm}^{-2}\text{s}^{-1}$ at a gas load compatible with a low cross section for pumping around the interaction region. Furthermore, by having several hundred interactions within one pellet, it is possible to track its flight path and determine the individual interaction points precisely.
- The second option is a cluster jet target which sends an ultra-dense hydrogen jet through the beam. It provides a homogeneous stream of gas which is easy to handle from the accelerator point of view.

Currently, the R&D work is focussing on improving the densities such that the design luminosity of PANDA can be reached. However, the achieved densities are still well below 10^{16} cm^{-2} .

As the requirements on a target for different types of experiments are manifold, it is not clear, whether one target will be able to fulfill all of them. Thus currently both targets are foreseen on equal footing and would fit into the detector. A cluster jet target or a pellet target can also be used for reactions with nuclei. However, in this case higher luminosities and a better definition of the interaction point are provided by using wire or strip targets. The use of an internal gas storage cell, e.g. a target of polarized ^3He , is proposed and has to be studied.

3.3.5 Target Spectrometer

The defining element of the target spectrometer is the superconducting solenoidal magnet. It has a length of 2.5 m, a diameter of 1.9 m and an axial field of 2 T. It has to accommodate a gap for pipes of the target device. The target spectrometer is made up of the following components:

- The interaction point is surrounded by a Micro Vertex Detector (MVD) which has five barrel shaped layers plus five disk-shaped detectors in forward direction. The three innermost layers are composed of pixel detectors to achieve best resolution and to be able to easily detect decay vertices displaced from the interaction point. The outer layers are composed

of microstrip detectors which are easier to handle. The baseline technology chosen for the pixel detectors are hybrid active pixel sensors as used by several LHC experiments. The electronics still has to be modified to accommodate continuous readout. As alternatives to silicon pixels, GaAs based detectors are considered as well as much thinner monolithic pixel sensors where the problem of radiation hardness would have to be solved.

- The MVD is surrounded by a cylindrical tracker. Two options are currently discussed, a straw tube tracker (STT) consisting of a set of double layers of self-supporting straws and a time projection chamber (TPC) with continuous readout. The TPC is the technically more challenging option since it requires an ungated charge collection based on a Gas Electron Multiplier (GEM) readout. However it has the benefit of less material and offers in addition particle identification via dE/dx . On the other hand, the STT is seen as a safe fall-back solution which should still fulfil the basic tracking requirements. In the forward direction circular or octagonal mini drift chambers are used to track particles with higher momenta before they enter the forward spectrometer.
- The next detector is a Cherenkov counter based on the so-called DIRC principle (Detector for Internally Reflected Cherenkov Light) as used in BaBar at SLAC. It consists of quartz rods in which Cherenkov light is internally reflected to an array of photon detectors in the backwards direction. The readout can be

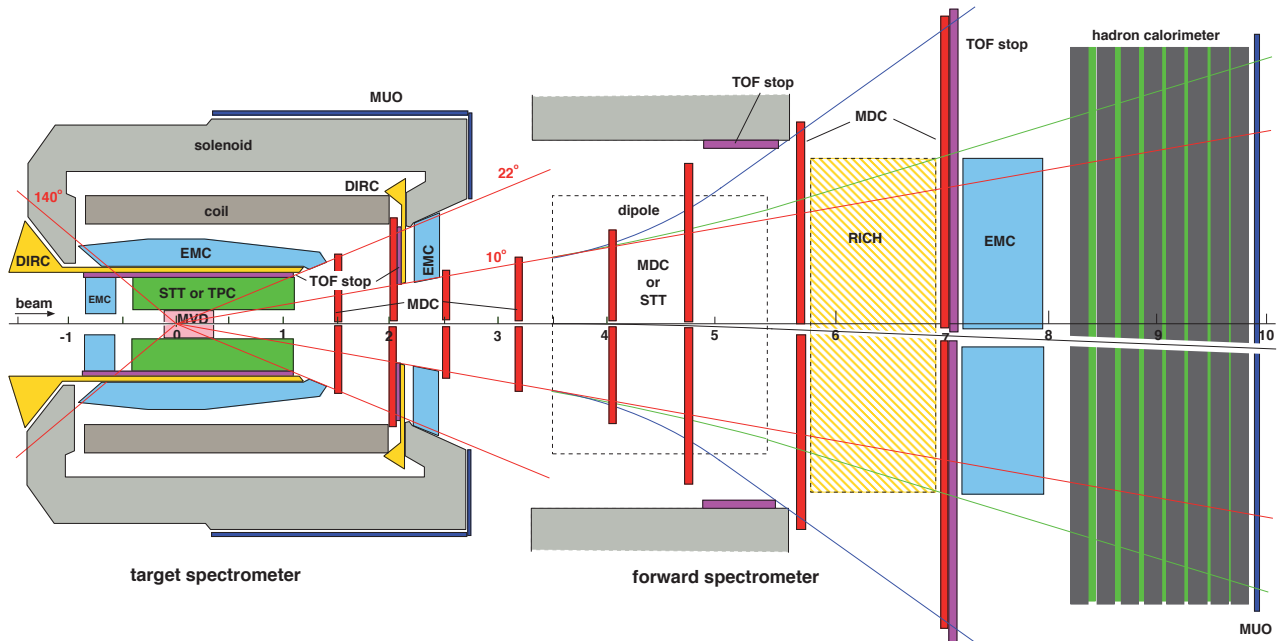

Figure 3.3: Setup of the PANDA detector.

either done by imaging a 2D pattern of reflections with a large number of PMTs or APDs or by measuring just one coordinate and the time of light propagation inside the quartz very precisely. In forward direction a disk-shaped Cherenkov counter with quartz radiator and detectors for internally reflected light similar as for the barrel DIRC is planned. Its readout should be located between the solenoid coil and the return yoke to allow the calorimeter end cap to be as close as possible.

- An electromagnetic calorimeter is placed outside the DIRC. It consists of a barrel part with 11360 crystals, a forward end cap with 6864 crystals and a backward end cap with 816 crystals. As detector material PbWO_4 is foreseen, since it is fast and has a reasonable resolution. As alternative BGO with still higher light yield albeit slower signals is considered.
- Finally, outside the superconducting magnet and its iron return yoke, drift tubes track muons exiting the spectrometer.

The necessity of a time-of-flight detector in the target spectrometer is still under discussion. Although the flight path is short, low momentum particles could still be identified.

3.3.6 Forward Spectrometer

The heart of the forward spectrometer is a dipole magnet with a large opening and a field integral of 2 Tm. This will provide the required momentum resolution for forward tracks with momenta up to 8 GeV/c.

One problem of the dipole magnet is the deflection of the beam. If included in the beamline design it can be countered by a magnet chicane. Otherwise the beam could be shielded from the magnetic field, introducing some material in the acceptance. A completely different option would be the usage of a toroidal magnet in the forward spectrometer. Although providing an azimuthal symmetry nicely matching to the target spectrometer it reduces the acceptance at small angles and requires the instrumentation of a larger area with trackers and calorimeters. The detector systems in the forward spectrometer are summarized in the following:

- Tracking is provided by mini drift chambers. Before the magnet, they have the same octagonal shape as in the end cap of the target spectrometer. After the magnet, a rectangular shape matches is more suitable for the spread of tracks. The use of straw tube trackers inside the dipole field is considered for better momentum resolution.

- The option of a third Cherenkov counter, based on gas or aerogel is still under investigation. In addition, a time-of-flight detector is considered for charged particle identification.
- An electromagnetic calorimeter based on lead/scintillator sampling and WLS fibre readout (Shashlyk type) is foreseen in the forward spectrometer. It should have 276 channels to cover the acceptance and will reach a resolution in the range of 3-5%/√E [GeV].
- After the electromagnetic calorimeter, the use of the MIRAC detector from WA80 at CERN is under investigation as a hadron calorimeter after refurbishing its readout.
- The last piece of equipment is a muon detector based on drift tubes.

3.3.7 Data Acquisition and Trigger

The selected readout and trigger concept foresees continuous digitization of all detector channels. Special trigger hardware is not foreseen. The readout electronics has to be fully pipelined and has to perform autonomously the detection of valid hits as well as intelligent data reduction by clusterization, signal shape analysis, and time reconstruction to transfer only the physically relevant minimum of information. All data are marked by a synchronous time-stamp by which event building can be performed at a later stage.

The data are fed into a configurable network. Attached computer nodes with the required bandwidth digest the full rate of certain sub-detectors used for the first selection level. Other detectors transfer data only for time slices selected on some level. Parallel selections are possible and several levels will bring the data rate down to the required 100-200 MB/s to mass storage. The clear advantage of this scheme is its flexibility: Any conceivable physics signature of an interesting process measurable by the PANDA detector could be converted into a sequence of selection algorithms. Typical signatures are the decays of J/ψ to leptons, decay vertices of charm or strange hadrons, identified kaons or electromagnetic showers, etc. The level of complexity is only limited by the required processing power and can be scaled up by attaching more nodes.

The trigger system and the universality of the detector make PANDA a unique tool in hadron physics, ready for future challenges.

3.4 The Phase Diagram of Strongly Interacting Matter - the CBM Collaboration

The Compressed Baryonic Matter (CBM) Collaboration, comprising about 350 scientists, aims for the investigation of strongly interacting matter at very high baryon densities including the question of deconfinement and chiral phase transitions. The envisaged research is complementary to the programs conducted at the Relativistic Heavy Ion Collider (RHIC) at BNL and at the future Large Hadron Collider (LHC) at CERN which focuses on the study of the phase diagram at high temperatures. CBM is designed to operate at interaction rates of up to 10^7 reactions per second with multiplicities of up to ~ 1000 charged particles per nucleus-nucleus collision event. Such parameters require unprecedented detector performance in terms of read-out speed and radiation hardness.

3.4.1 Exploring the QCD Phase Diagram with Heavy-ion Collisions

In the laboratory, hot and dense nuclear matter can be generated in a wide range of temperatures and densities by colliding atomic nuclei at high energies. In the collision zone, the matter is heated and compressed for a very short period of time. If the energy pumped into this fireball is sufficiently large the quark-gluon substructure of nucleons comes into play. At first, nucleons are excited to short-lived states (baryonic resonances) which decay by the emission of mesons. At higher temperatures, also baryon-antibaryon pairs are created. This mixture of

baryons, antibaryons and mesons, all strongly interacting particles, is generally called hadronic matter, or baryonic matter if baryons prevail. At even higher temperatures or densities the hadrons melt, and the constituents, the quarks and gluons, may move freely forming a new phase, the Quark-Gluon-Plasma. At very high densities but very low temperatures, correlated quark-quark pairs are predicted to form a color superconductor. These phases predicted for strongly interacting matter are illustrated in Fig. 3.4.

Heavy-ion experiments at RHIC and the future LHC aim at the study of strongly interacting matter at extremely high temperatures and low net baryon densities, i.e. at very small values of the baryon chemical potential. In this region of the phase diagram the transition is expected to be a smooth crossover from hadronic to partonic matter. Recent Lattice QCD calculations found strong indications for the existence of a critical endpoint at relatively large values of the baryon chemical potential. Beyond this critical endpoint, for larger values of the baryon chemical potential (and for lower temperatures), one expects a first order phase transition from hadronic to partonic matter. This is the regime of high baryon densities which will be investigated in detail by the CBM experiment. Nucleus-nucleus collisions at FAIR energies cover a large area of the QCD phase diagram ranging from dense nuclear and hadronic matter to the first order phase transition, potentially including its critical

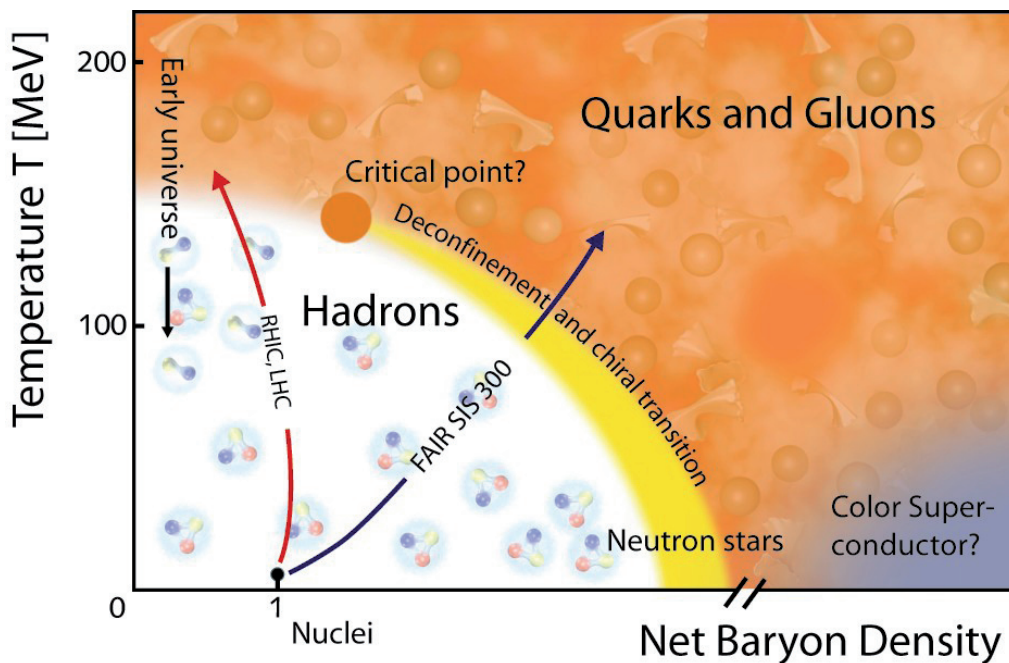

Figure 3.4: Schematic illustration of the phase diagram of strongly interacting matter.

endpoint. The discovery of the critical endpoint would be a breakthrough in high-energy heavy-ion research, as this observation would constitute the first direct signature for the deconfinement phase transition.

3.4.2 The Scientific Goals of the CBM Experiment

The high-intensity heavy-ion beams of the future FAIR accelerators, together with the planned Compressed Baryonic Matter (CBM) experiment, offer excellent opportunities to produce and to investigate baryonic matter at highest densities in the laboratory. The research program comprises the study of the structure and the equation-of-state of baryonic matter at densities comparable to the ones in the inner core of neutron stars. This includes the search for the phase boundary between hadronic and partonic matter, the critical endpoint, and the search for signatures for the onset of chiral symmetry restoration at high net-baryon densities.

The experimental and theoretical challenge is to study probes which address the physics topics mentioned above. In high-energy nucleus-nucleus collisions the evolution of the fireball - from the early hot and dense stage to its disintegration into hadrons - takes only a few 10^{-23} s. The experimental observables are the yields and phase-space distributions of newly created particles, and their correlations and fluctuations. Different particle species probe different phases of the transient fireball depending on their mass, energy, production and interaction cross sections and decay channels.

Particles containing heavy quarks like charm are created in the early phase of the collision, in particular at FAIR energies which are close to the threshold for the production of charm-anticharm pairs. Therefore, the yield and the phase space distributions of charmed particles are expected to be particularly sensitive to the conditions inside the evolving early fireball. Most of the charm quarks are carried away in D-mesons which contain one charm and one light quark. Theory predicts that the properties of D-mesons are modified in the dense medium, and, hence, offer the possibility to study the effect of chiral symmetry restoration at highest densities. Some of the created charm-anticharm pairs form charmonium which disintegrates much easier in quark-gluon matter than in hadronic matter, thus probing the structure of the fireball. No charmed particles have been measured in the FAIR energy range.

A direct view into the hot and dense fireball is provided by short-lived vector mesons decaying into electron-positron or muon pairs. These leptons do not interact strongly and thus act as penetrating probes. From the invariant mass distribution of the dilepton pairs one can extract the in-medium spectral functions of the vector mesons which contain information on the effect of chiral

symmetry restoration. Up to now, dilepton mass spectra have not been measured in the FAIR energy range.

Heavy particles containing strange quarks like ϕ -mesons (strange - antistrange pair), Ξ hyperons (two strange quarks and one light quark) or Ω hyperons (three strange quarks) are produced in the high temperature and high density phase but may decouple soon from the fireball due to their low interaction cross sections with hadronic matter. Their yields, momentum and angular distributions may be affected by the conditions inside the reaction zone.

In the final dilute stage of the collision the participant hadrons cease to interact and the abundance of the various particle species is frozen. The pion and kaon yields reflect the amount of entropy and strangeness created in the collision. A detailed experimental study of the correlations and fluctuations of the most abundant particles provides information on the bulk properties of the fireball. The collective motion of the emitted particles can be related to the compressibility of the hot and dense matter as described by its equation-of-state. In atomic matter, in the vicinity of the critical endpoint of a first order phase transition, a strong enhancement of density fluctuations occurs, causing critical opalescence. In the case of heavy-ion collisions, similar critical phenomena are expected, thus an enhancement of fluctuations of particle yields or of their mean transverse momentum at a given beam energy has been proposed as a signature for the critical endpoint. These dynamical, i.e. non-statistical fluctuations have to be measured event-by-event which requires a detector with a large acceptance and excellent particle identification capability.

The observation of thermal radiation from the collision zone would give direct experimental access to the fireball temperature. However, these photons are notoriously difficult to extract from the measured photon spectrum which is dominated by decay photons. Recently, the analysis of two-photon correlations opened the possibility to disentangle photons from the dense and hot fireball and decay photons.

The CBM experimental program includes the investigation of nucleus-nucleus collisions at beam energies from about 10 GeV/u to 35 GeV/u for lead projectiles and up to 45 GeV/u for symmetric projectile nuclei ($Z/A=0.5$). The aim is to provide a comprehensive and precise data set based on the measurements of the observables mentioned above for a variety of projectile and target masses, beam energies, and impact parameters. Important for the interpretation of results of the heavy-ion collision experiments are comparisons to data obtained in proton-nucleus and proton-proton collisions. The FAIR accelerators deliver proton beams up to an energy of 90 GeV which permits investigations

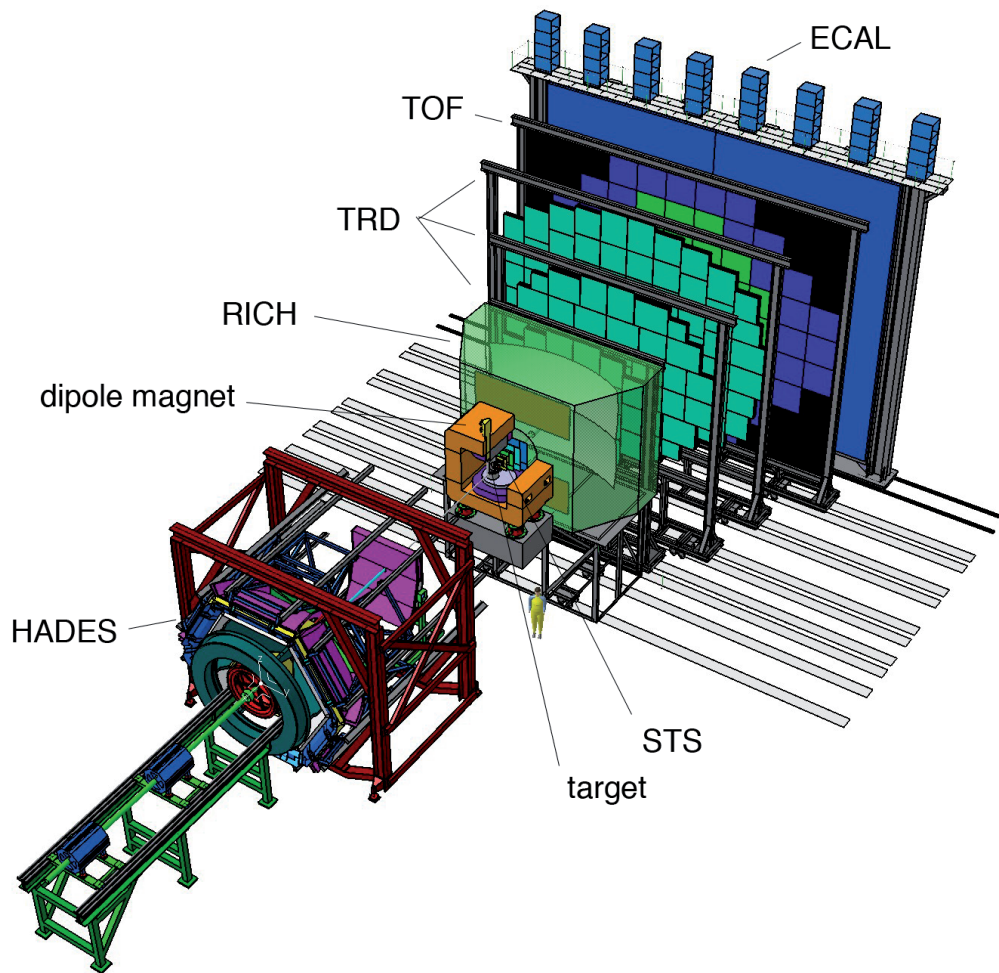

Figure 3.5: Schematic view of the Compressed Baryonic Matter (CBM) experiment planned at FAIR. The setup consists of a high resolution Silicon Tracking System (STS), a Ring Imaging Cherenkov detector (RICH), three stations of Transition Radiation Detectors (TRD), a time-of-flight (TOF) system made of Resistive Plate Chambers (RPC) and an Electromagnetic Calorimeter (ECAL). The HADES spectrometer which will be used for experiments between 2 and 10 GeV/u beam energy, is located upstream the CBM target.

of elementary processes like charm production in an energy range where no data exist. Nuclear reactions in the energy range from 2 to 10 GeV/u will be studied with an upgraded HADES spectrometer, which is currently being operated at the GSI SIS-18 accelerator.

3.4.3 The CBM Detector Concept

The CBM collaboration proposes to build a universal detection system in order to fully exploit the physics potential of nucleus-nucleus collisions at FAIR. The proposed detector will be capable of simultaneously measuring both, hadrons and leptons, over a large geometrical acceptance. A key feature of the apparatus will be its capability to perform high-rate measurements which are needed for the identification of rare probes, such as the D-meson and charmonium, in a large background of charged particles. The experimental setup will be operated at interaction rates of up to 10^7

reactions per second with multiplicities of up to ~ 1000 charged particles per central gold-gold collision. Such conditions require unprecedented detector performances in terms of read-out speed and radiation hardness.

A schematic view of the proposed CBM detector concept is shown in Fig. 3.5 together with the HADES spectrometer. In the present design, the STS consists of three planar layers of silicon-pixel detectors downstream from the target followed by four layers of micro-strip detectors which provide excellent tracking capabilities and secondary vertex reconstruction even in the anticipated high track density environment. The STS is located inside the large gap of the dipole magnet for momentum determination with a precision of better than 1%. The task of the RICH detector will be to identify electrons and to provide suppression of pions in the momentum range of electrons from low-mass vector-meson decays. The TRD detector will provide charged particle tracking and

the identification of high energy electrons and positrons. The technical task is to develop highly granular gaseous detectors operating at rates up to 100 kHz/cm². At the same time, a pion rejection factor of several hundred at an electron detection efficiency of 90% should be achieved. Hadron identification will be performed using a TOF wall consisting of a RPC array. The key issues here are the high rate capability, low resistivity material, long-term stability and the realization of large arrays with overall excellent timing performance. The required time precision should be well below 100 picoseconds and the expected particle flux for the innermost part of the detector is up to 25 kHz/cm². The ECAL will be used for the identification of electrons and photons.

A particularly challenging aspect of CBM is the requirement for a high-speed data acquisition (DAQ) architecture and the appropriate trigger concept. The DAQ system has to provide the necessary bandwidth to process sufficient events for an efficient reconstruction of rare probes and should also permit a high degree of flexibility in order to be adjustable to the different physics needs of the experiment.

The CBM detector components are currently the object of intensive research and development activities carried out by different groups within the collaboration and achievable technical solutions have been proposed for all components.

3.4.4 Feasibility and Performance Studies

Detailed simulations concentrate on the optimization of the detector configuration in order to assure that the key observables are accessible with sufficient precision. The studies are based on efficient track- and vertex reconstruction algorithms which take into account a realistic response of the Silicon detectors including possible event pile-up. One of the benchmark observables are the D-mesons which will be identified via their hadronic decay

into one or two pions and a kaon. This measurement poses a major challenge to the Silicon tracker and an online event selection: the decay vertex of the D-meson - which is displaced from the main vertex of the collision by several 10 μm - has to be determined with an accuracy of about 50 μm in order to suppress the overwhelming combinatorial background caused by pions and kaons directly emitted from the fireball. The simulations show that an event suppression factor of about 1000 can be achieved when using a thin and highly granulated vertex pixel detector. This factor is sufficient for effectively triggering on D-meson candidates even in gold-on-gold collisions at reaction rates up to 10 MHz.

Another key observable are short-lived vector-mesons which decay into lepton pairs with a branching ratio of 10^{-4} - 10^{-5} . The major challenge, both for the measurement and for the data analysis, is to suppress the physical background of electron-positron pairs from Dalitz decays and gamma conversion. According to simulations based on an optimized Silicon tracker configuration one expects a signal-to-combinatorial background ratio of about 0.5 for ω - and ϕ -mesons in central gold-on-gold collisions at an energy of 25 GeV/u. This analysis requires a pion suppression factor of 10^4 which can be achieved by the combined performance of RICH and TRD.

The measurement of fluctuations and correlations requires a large detector acceptance with full azimuthal coverage, and excellent particle identification capabilities for a wide range of beam energies. Simulations demonstrate that the CBM setup permits to measure event-by-event dynamical fluctuations of the kaon-to-pion ratio down to a level of 2%.

The CBM Collaboration - which currently consists of about 350 scientists from more than 40 institutes and 15 countries - will prepare Technical Design Reports for the different detector components until 2011, and will start with the experimental program in 2015.

3.5 High Energy Density Bulk Matter Generated with Intense Heavy Ion and Laser Beams - the HEDgeHOB and the WDM Collaborations

FAIR will deliver very intense, bunched and highly focused heavy-ion beams of all ion species up to uranium. Such beams will deposit hundreds of kJ/g specific energy in solid matter that will induce exotic states of High-Energy-Density (HED) in the material. A strong plasma physics community, comprising about 120 scientists and organized within the “High Energy Density generated Heavy-ion Beams-Collaboration (HEDgeHOB)”, aims for utilizing the powerful ion beams from FAIR to carry out novel research into matter under extreme conditions of temperature and pressure; similar conditions are believed to prevail in the interiors of stars, brown dwarfs and giant planets. A second group comprising about 60 scientists organised in the ‘Warm Dense Matter’ (WDM) collaboration will focus on the optical properties of matter under these exotic conditions. This research will largely benefit from the availability of the kilojoule/petawatt laser facility PHELIX, which is presently being set up at GSI.

3.5.1 Physics Motivation

In the environment that we are used to, matter occurs predominantly in the solid, liquid or gaseous phase. However, in the universe at large, the situation is quite different. The small fraction of visible matter exists predominantly either as hot dense plasma in the interior of stars or in stellar atmospheres, as medium- or low-temperature dense plasma in the interior of large planets, or as hot plasma of very low density in interstellar space. In particular the regime of dense plasmas is so far only scarcely explored, since it is difficult to approach experimentally. This regime corresponds to states of matter at specific energies of larger than 10^5 J/cm³ or equivalent pressures of 1 Mbar and above, which are classified as High-Energy-Density (HED) matter.

Intense heavy-ion beams provide an efficient tool to create large samples of HED matter (with volumes of the order of a few mm³ or even cm³ and lifetimes of the order of several ten’s of nanoseconds) by isochoric and uniform heating of solid matter. The uniform physical conditions and comparatively long life times facilitate application of a broad spectrum of the diagnostic tools for studying these HED states of matter. Already today GSI accelerators deliver the most intense heavy ion beam for plasma physics experiments. The beam parameters of the new FAIR facility outnumber the current status in many respects: The specific energy deposition, for example, will increase from 1 kJ/g, which is a typical value for current experiments, to about 600 J/g, and the specific power deposition from 1 gigawatt/g to 12 terawatts/g.

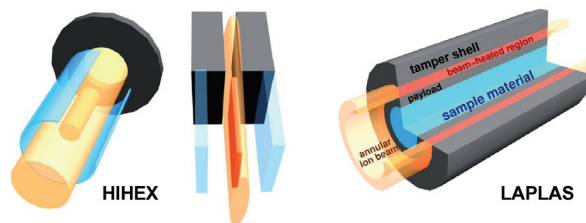

Figure 3.6: Experimental concepts and beam-target configurations of the proposed HEDgeHOB experiments. HIHEX (Heavy Ion Heating and Expansion) experiments: to measure equation of state (EOS) data by quasi-isochoric heating and isentropic expansion. Shown is a cylindrical and planar target geometry. The beam comes from behind and heats the target material (small orange cylinder or thin orange foil, respectively). LAPLAS (Laboratory Planetary Sciences): low-entropy cylindrical compression of matter.

3.5.2 Research Program

The research program envisaged at FAIR will focus the equation of state of metals in so far unexplored regions of the phase diagram, the properties of compressed matter at medium temperatures, and related to these major goals, studies of the interaction of intense ion and laser radiation with heated and compressed matter, radiation hydrodynamics, magneto-hydrodynamics, etc. Two complementary experimental concepts are proposed by the HEDgeHOB collaboration (Fig. 3.6):

HIHEX (Heavy Ion Heating and Expansion): In the HIHEX experiment, a cylindrical or plane target is heated fast compared to the hydrodynamic expansion time. By such quasi-isochoric heating, high entropy states as well as high energy density states are generated. After heating, the sample isentropically expands and passes through the regions of interest in the phase diagram. The variability of the beam focus at the target allows for cylindrical and plane geometry. This allows in many cases to reduce the numerical description to a one dimensional problem.

LAPLAS (Laboratory Planetary Sciences): LAPLAS scenario makes use of cryogenic targets like solid hydrogen and other noble gases, confined by an outer cylinder of heavier material, such as lead or gold. The outside cylinder is heated by a beam with an annular focal spot. While the outer material is heated and subsequently expands, the inner cryogenic material is not heated, stays cold and is compressed by the expansion process of the outer cylinder. This ensures compression of the investigated material at low entropy.

The WDM-experiments intend to explore the radiative properties and related atomic physics issues of heavy ion beam generated dense strongly coupled plasmas. In order to confine targets even at longer pulse lengths while keeping them transparent for diagnostic purposes, WDM has proposed the dynamic confinement scheme where the expansion of the inner material can be counteracted by the expansion of the very thin outer transparent cylinder. The aim of this experimental scheme is to achieve isochoric heating of low-Z materials even for long pulses.

When the pulse lengths is sufficiently short, the radiative properties of Warm Dense Matter samples can be explored even without the confining outer shell.

X-ray Thomson scattering driven by the PHELIX laser is proposed to independently characterise the WDM samples and to benchmark the spectroscopically recorded radiation emission and related atomic physics in dense environments.

LAPLAS and HIHEX will use diagnostic tools such as Thomson scattering, x-ray backlighting and proton radiography to characterize the states which have been achieved. WDM will essentially employ spectrally resolved x-ray scattering diagnostics where the Petawatt High Energy Laser PHELIX will play a key role.

3.5.3 Instrumentation at FAIR

In order to exploit the accelerator facilities in the most optimal way, a dedicated experimental area has been specially designed for the Plasma Physics experiments at FAIR (Fig. 3.7). Two separate beam transport lines are coming from the SIS-100 synchrotron to the Plasma Physics cave. The ion-optical characteristics of these beam lines are optimized for different experiments. The left beam line is designed for the HIHEX experiment and allows for extremely strong final beam focusing and non-linear beam shaping. This is needed for efficient heating of the samples in order to achieve high entropy states in matter. The beam-heated material can then expand isentropically reaching different interesting physical states that are to be investigated in the HIHEX experiment.

The second beam line is designed for the LAPLAS and WDM experiments. LAPLAS in addition need a hollow beam with a ring-shaped focal spot whereas WDM employs the much more simple usual Gaussian beam profile. Such a beam is generated by a high-frequency beam rotator (wobbler) which forces the beam to make about 10 full circles at the target within the beam pulse duration of 50 ns that is sufficient to achieve the necessary level of the irradiation symmetry and homogeneity. Using such a beam, the sample material

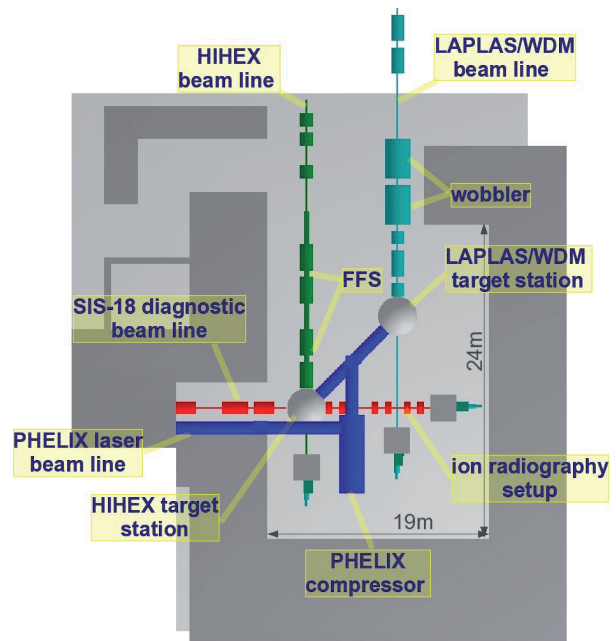

Figure 3.7: Layout of the Plasma Physics experimental area at FAIR. The HIHEX (green) and LAPLAS/WDM (cyan) SIS-100 beam lines are coming from the top of the picture. The diagnostic SIS-18 beam line (red) and PHELIX laser beam line (blue) are shown as well.

like solid hydrogen, deuterium or water ice that is enclosed in a heavy cylindrical tamper shell can be strongly compressed while preserving low temperature. By such fairly ideal low-entropy cylindrical compression, one can reach the high pressure states that are the subject of the LAPLAS experiment. This beam line is also equipped with an elaborate cryogenic target preparation and handling system needed for both LAPLAS and WDM experiments.

The high energy Petawatt PHELIX laser beam is requested for the HIHEX, LAPLAS target stations for diagnostics purposes. In addition, a 90° ion beam from the SIS-18 synchrotron allows for high-resolution ion and proton radiography in the HIHEX experiment.

The high energy Petawatt PHELIX laser beam is also requested for the WDM target station, however, no SIS-18 nor proton radiography are needed as they are not useful for the WDM research program.

3.6 Atomic and Fundamental Physics with Highly Charged Ions and Antiprotons - the SPARC and the FLAIR Collaborations

FAIR promises the highest intensities for relativistic beams of stable and unstable heavy nuclei, combined with the strongest available electromagnetic fields, allowing extension of atomic spectroscopy and collision studies across virtually the full range of atomic matter. Moreover, the new facility will produce the highest flux of cooled antiprotons worldwide and will facilitate the creation of low-energy antiprotons at high intensities and brilliances to be used in a physics program including atomic collision studies and precision spectroscopy of antiprotonic atoms and of antihydrogen. Organized within the Stored Particle Atomic Physics Research Collaboration (SPARC) and the Facility for Low-energy Antiproton Ion Research Collaboration (FLAIR), a large community of around 350 scientists will exploit these new opportunities for a challenging program on atomic and fundamental physics research.

3.6.1 Atomic Physics with Highly Charged Ions

The atomic physics program planned by the SPARC Collaboration will focus on to two major research themes, fundamental interactions between electrons and heavy nuclei (in particular the interactions described by Quantum Electrodynamics, QED) and collision dynamics in strong electromagnetic fields. Moreover, atomic physics techniques will be used to determine properties of stable and unstable nuclei and to perform tests on predictions of fundamental theories besides QED.

The SPARC Collaboration plans essentially for the four classes of experimental studies:

Highly relativistic heavy ions will be employed for a wide range of collision studies involving photons, electrons and atoms, exploiting the large Doppler boost and the rapidly varying fields in those reactions. An understanding of these collision phenomena is required for all lines of research in atomic physics, including the interaction in solids (material research) or in living cells (radiobiology), and also for accelerator technology. The Doppler boost will also allow completely new experiments using laser excitation.

High-energy beams will be utilized for achieving high stages of ionization up to bare uranium nuclei. Experiments will focus on structure and collision studies for these ion species, a field being still largely unexplored but intimately connected to astrophysics. It also facilitates precision investigations of bound state QED in extremely strong electromagnetic fields, e.g. for the ground-state of high-Z ions.

Fundamental atomic physics studies and model-independent determination of nuclear quantities with stable as well as radioactive atoms in well-defined charge states will be performed, through the application of atomic physics methods. Important for this class of experiments will be the slowing-down, trapping and cooling of particles in the ion trap facility HITRAP, enabling high-accuracy experiments in the realm of atomic and nuclear physics (e.g. g-factor measurements in heavy hydrogen-like ions), or collision studies by use of highly charged ions at extremely low energy.

Low-energy beams of high Z few-electron ions will be employed for collisions characterized by very large Sommerfeld parameters q/v . In this domain of strong perturbations, the ionization mechanism is unclear. No perturbation theories are applicable and corresponding experiments will be best suited to test the predictive power of the most advanced ab initio theories.

3.6.2 Instrumentation for SPARC

The experimental areas at the new facility provide a range of novel instrumentation for atomic and applied research:

The **high-energy area** for atomic physics will be supplied by ion beams from both SIS18 and SIS300. **SIS300** will provide an unprecedented combination of high intensities and acceleration of particles up to $\gamma = 35$. Additionally, laser installations will be available; in particular, the high power PHELIX facility will allow the study of interactions of the most intense laser fields with heavy ions.

The NESR (compare Fig. 3.8) will be of particular relevance for the atomic physics program. Compared to all other heavy-ion storage rings either currently in operation or planned, the NESR will be the most flexible, providing the most intense beams available, including bare uranium. The intense beams of highly-charged radioactive ions make novel experiments possible at the interface of atomic and nuclear physics. Moreover, new instrumentation will be available, such as an internal gas jet, an ultra-cold electron target, and electron bunches provided by the electron collider for interactions with collinear high-intensity laser pulses. The unprecedented resolution provided by the electron target will facilitate measurement of suitable line shapes, providing the opportunity to measure resonance profiles due to di-electronic recombination to a level where QED effects manifest in the observed line-shapes,

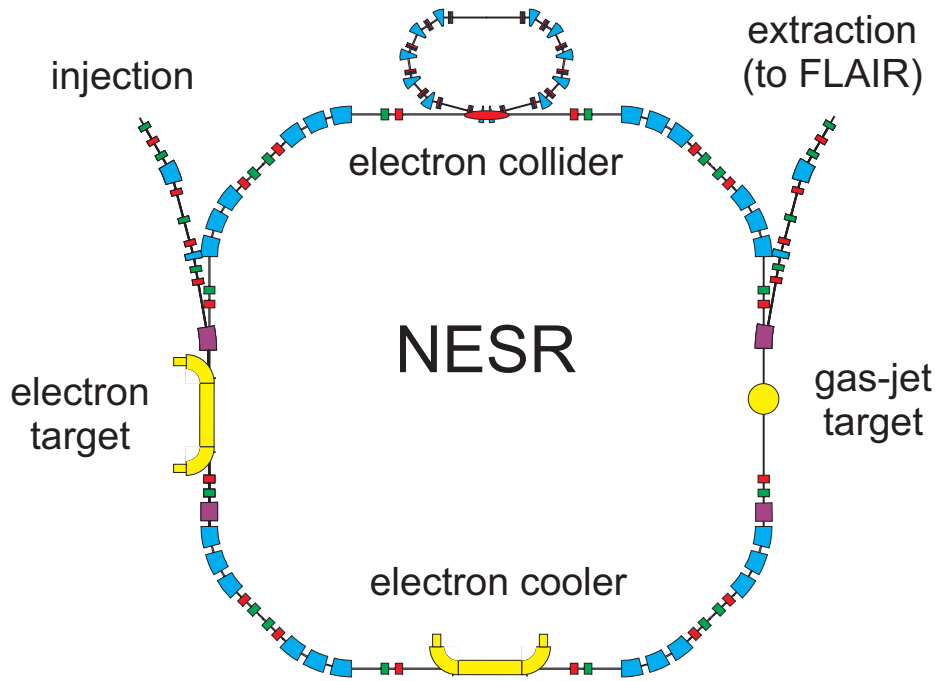

Figure 3.8: The New Experimental Storage Ring NESR with its instrumentation for atomic physics experiments.

thereby providing a significant new test of dynamical QED. Products of interactions with the internal target can be detected by a suite of spectrometers including X-ray crystal spectrometers (3-120 keV energy range), low-temperature calorimeters, a Compton polarimeter, an electron spectrometer and an extended reaction microscope with many of the products being detected with almost 4π acceptance. This facilitates a large range of new, kinematically complete collision experiments, as well as new tests of high field QED through spectroscopy of the subsequent transitions.

Low-Energy Cave and FLAIR Building The interaction of the highly charged ions, in the energy range of 130 MeV/u to < 100 keV/u, with composite targets (molecules, clusters, nanostructures and solids) will be investigated, in the new Atomic Physics low-energy cave located in the FLAIR (Facility of Low-Energy Antiproton and Ion Research) building. This experimental area will be served by the NESR. In the building, different installations (e.g. the Low-Energy Storage Ring LSR, the Ultra-low energy Storage Ring USR, and HITRAP) are located. From the LSR the ions can be actively slowed down, even to rest using the trap facility HITRAP. The installations will be shared with the FLAIR collaboration (see below).

3.6.3 Physics with Low-Energy Antiprotons

The physics program envisaged with low-energy antiprotons covers a wide range of atomic, nuclear and particle physics

Precision spectroscopy of antiprotonic atoms and antihydrogen for tests of fundamental interactions and symmetries is the main topic of current low-energy antiproton physics at the Antiproton Decelerator (AD) of CERN. Antihydrogen, the simplest form of neutral antimatter consisting of an antiproton and a positron, promises one of the most precise tests of CPT symmetry through precision laser and microwave spectroscopy and comparison to hydrogen, the experimentally best studied atom. In order to reach the ultimate precision it is necessary to trap the antihydrogen atoms in a neutral-atom trap and to laser-cool them to submilli-Kelvin temperatures. These extremely difficult experimental techniques will need many more years of development and will dominate the antihydrogen physics program at FLAIR. With the availability of laser-cooled antihydrogen, for the first time experiments on the gravitational properties of antimatter will become possible.

Interaction of antimatter with matter: exploring sub-femtosecond correlated dynamics is another major program at FLAIR. Here, atomic collision processes like ionisation by ultra-low energy antiprotons will be investigated. Antiprotons are a unique probe for these processes since they do not undergo charge screening like protons. Experimental data are scarce so far due to the unavailability of high-quality antiproton beams at these energies, and theoretical predictions vary considerably. At energies below about 500 keV down to 1 keV the interaction time between an antiproton passing atoms or molecules (70 attoseconds to 1 femtosecond) is comparable to the revolution time of outer-shell electrons

in atoms or molecules. Moreover, the antiprotons's electric field is so strong that any perturbative theoretical approach must fail. Therefore, slow antiprotons provide an unsurpassed, precise and unique tool to study many-electron dynamics in the strongly correlated, non-linear, sub-femtosecond time regime, the most interesting and, at the same time, most challenging domain for theory. A novel electrostatic storage ring for low-energy antiprotons, improving the luminosity by several orders of magnitude, equipped with state-of-the-art imaging momentum spectrometers to record, simultaneously, the vector momenta of several emitted electrons and ions ("Reaction Microscopes"), will allow for the first time detailed experimental studies in this regime.

Nuclear and particle physics with antiprotons is currently impossible because of the availability of only fast extracted antiprotons, i.e. pulsed beam at the AD. Already at LEAR, measurements of X-rays from light and heavy nuclei have been used to investigate the nucleon-antinucleon interaction at threshold or the nuclear periphery. With the availability of unstable nuclei at FAIR, these techniques can be extended to investigate the structure of unstable nuclei with antiprotons. Other ideas include the production of strangeness -2 systems or the production of nuclear clusters containing two

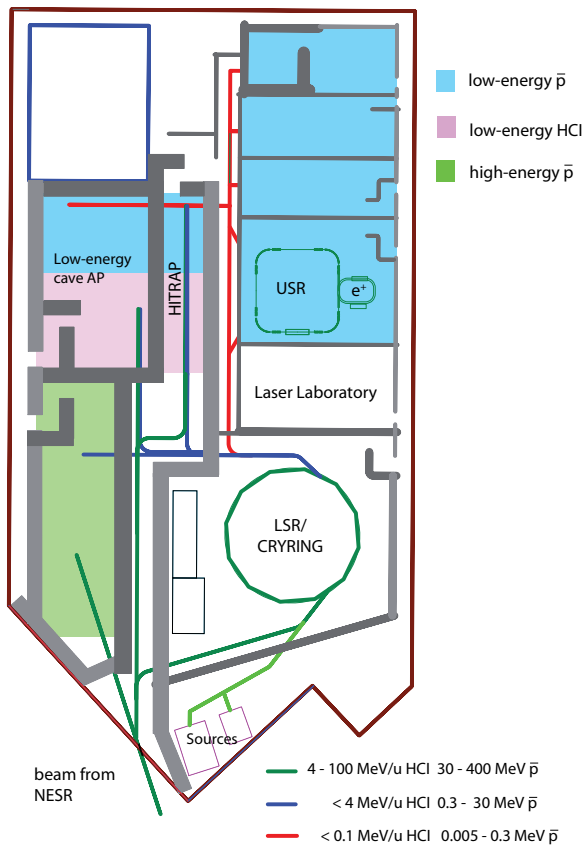

Figure 3.9: Layout of FLAIR

Kaons. For the latter, densities of 5-6 times normal nuclear density have been predicted, thus, reaching in the phase diagram of hadronic matter conditions where phase transitions to kaon condensation or colour superconductivity at low temperature may be possible.

3.6.4 The FLAIR Facility

To make use of the world wide highest flux of antiprotons, as available at FAIR, a next generation low-energy antiproton facility, a proposal was made for dedicated experimental area, the Facility for Low-Energy Antiproton and Ion Research (FLAIR, see Fig 3.9); an important synergy comes from the fact that the components of FLAIR can be equally well used for highly charged ions. To extend the performance over the existing facility one has to produce cooled beams of antiprotons down to energies well below 100 keV so that they can be efficiently captured in charged-particle traps or stopped in low-density gas. Furthermore, also continuous beam will be available for nuclear and particle physics type experiments.

The key instruments to achieve this are two storage rings, the Low-energy Storage Ring (LSR, 30 MeV-300 keV) followed by the Ultra-low energy Storage Ring (USR, 300 keV-20 keV) and the HITRAP facility. The LSR is the essential instrument of FLAIR, taking beams of 30 MeV antiprotons decelerating them to 300 keV. The best choice for LSR is the already existing CRYRING at the Manne Siegbahn Laboratory in Stockholm, which could be adapted for the new requirements (high-energy injection, extraction, fast deceleration) by the MSL team.

The USR, a challenging new development of a decelerating electrostatic storage ring under way at the Max-Planck-Institute for Nuclear Research in Heidelberg, can be both used for previously mentioned in-ring experiments with a reaction microscope or to extract ultra-low energy antiprotons into experimental areas.

A second possibility to obtain such low-energy antiprotons will be the capture, cooling, and extraction from HITRAP. Several experimental areas are foreseen both behind the USR and behind HITRAP for experiments at lowest antiproton energies.

Three more areas are foreseen that partly receive also higher-energy beams directly from the NESR. In the low-energy cave, in addition to studies with highly charged ions, ultra-low energy antiprotons extracted from HITRAP will be available.

Higher energy antiproton beams ($E_{\text{pbar}} < 300 \text{ MeV}$) will be available in two areas for nuclear and particle physics experiments and the study of medical applications.

3.7 High-Energy Irradiation Facility for Biophysics and Materials Research - the BIOMAT Collaboration

The FAIR synchrotrons SIS18 and SIS100 also offer new opportunities for radiobiology and materials research. To make use of the heavy-ion beams provided by SIS18 or SIS100, a dedicated multi-purpose irradiation facility (BIOMAT) will be installed at the high-energy beamline. It will be equipped with a magnetic scanner system, flexible irradiation set-ups and instrumentation for in-situ diagnostics of irradiated samples.

3.7.1 Science Case

The biophysics research program will focus on space radiation effects. Radiation represents a significant hazard in all space explorations, especially outside the protective shield of the Earth's magnetic field. Solar and galactic particle radiation consists primarily of protons and helium ions, but the relatively small number of heavier ions in the galactic cosmic radiation (GCR) can significantly contribute to radiation dose due to their high ionization energy loss. In humans, genetic alterations, cancer, and cataracts may already be induced by low levels of radiation.

There is also the potential for damage to space instrumentation, as the high charge locally deposited by energetic heavy ions can produce changes in computer chips and other electronic devices; frequently observed changes of the status of memory units are a prominent example. Since shielding is difficult and costly in space, the effects of the cosmic radiation should be known as accurately as possible in order to optimize the shielding

measures and to exploit the shielding properties of materials used for other purposes, such as the spacecraft hull, internal equipment, fuel and supplies.

The materials research will primarily focus on:

(i) heavy-ion induced modifications of solids that are exposed to extremely high pressures: to achieve this, the samples must be enclosed in a high pressure anvil cell. In order to irradiate pressurized samples with ions, the beam energy has to be sufficiently high to penetrate through one of the anvils of thickness in the range of mm to cm. When entering the solid, the projectiles deposit an enormous amount of energy within a very short time and in a very small volume (corresponding to very high power densities) and trigger many different processes including phase transitions, thermal spikes and pressure waves. Such processes may have direct implications in the field of geosciences with respect to geological formation and radioactive decay processes in the crust and upper mantle of the Earth;

(ii) analysis of material modifications induced by relativistic heavy ions: this concerns both short-time processes stimulated by the projectiles and final modifications of structure and other characteristics of the material. The signature of short-time processes comprises the emission of various particles such as electrons, ions, atoms, and molecules, and of electromagnetic radiation (such as X-rays and Cerenkov light). Their properties as for example intensity, energy, development in time, and

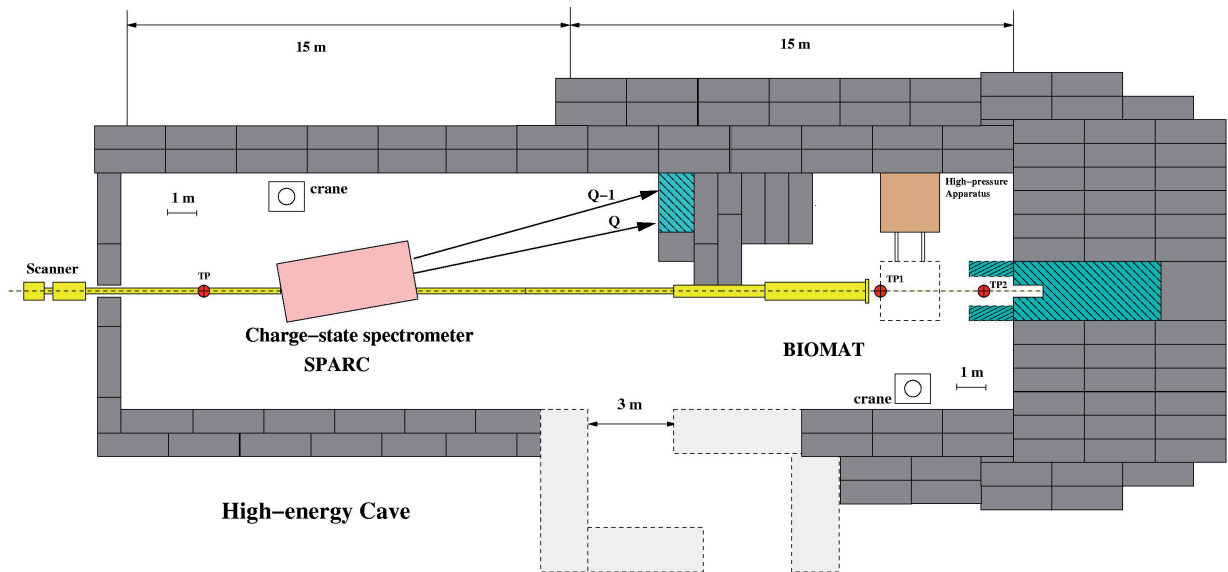

Figure 3.10: Layout of the high energy cave for SPARC and BIOMAT experiments.

spatial distribution, provide valuable insight in track formation processes. Furthermore, short and intense ion pulses are expected to stimulate new processes not observable under standard irradiation conditions;

(iii) radiation hardness of materials: studies in this direction aim for investigating the stability and specific modifications of different materials exposed to particle beams of high energy and intensity. This will for example allow us to test insulating materials exposed to high-dose environments or to select materials with the most favorable radiation shielding properties.

3.7.2 The BIOMAT Irradiation Facility

The BIOMAT facility will be located in the High-Energy Cave (Fig. 3.10), which is shared with the SPARC Collaboration. A key issue for the planned BIOMAT facility is setting up most flexible target stations and providing access to a wide range of different beam

parameters (such as kinetic energies, ion charge states etc). The High-Energy Cave will thus be connected to both the SIS18 and the SIS100 synchrotron. To allow high-quality irradiations of larger sample areas, a magnetic beam scanner will be installed. Additionally, a passive scattering system will be provided. The main target station will comprise various flexible set-ups such as a remote controlled moving belt for positioning of smaller samples and larger devices (e.g. detectors, space devices) together with a robotic system for automatic handling of biological samples. Irradiation experiments on samples exposed to extreme pressure conditions will be performed in a high-pressure device equipped with a large-volume multi-anvil cell. Finally, for basic studies allowing in-situ and on-line monitoring of ion induced processes, a multi-purpose UHV-chamber is planned. An additional target set-up in close vicinity of the beam dump will allow experiments with extreme beam conditions with respect to flux and beam energy.

3.8 Offline Computing for FAIR Experiments

At the current point in time it is very difficult to propose a strategy for offline computing at FAIR. The input from the experiments is in constant flux, and even the border between online and offline is not yet exactly defined and may change. On the other hand, the basic technology of computing, hardware and software is in a continuous state of evolution and even with exact input numbers from the experiments it would therefore be too early to recommend a computing model.

From a computing resources point of view the two most demanding FAIR experiments, CBM and PANDA, have similar requirements as LHC experiments in terms of data acquisition rates. In that respect CBM is comparable to Alice, PANDA to the proton-proton experiments ATLAS or CMS. Therefore FAIR computing is expected to be in the same order of magnitude as LHC computing. But since the first year with all experiments at nominal data rate is 2015, the complexity and the cost are greatly reduced due to the later startup.

Following the example of the LHC computing project and taking into account the reduced complexity of the overall data flow and computation needs (although in specific areas, such as the CBM experiment, comparable or even higher requirements than for one of the LHC experiments may be necessary), it seems reasonable to organize a computing review in 2008, to estimate the detailed storage, management, simulation, reconstruction and analysis of the data for all FAIR experiments. Based on these results, and the experience of the then running LHC experiments, a plan for building up the FAIR computing facility should be developed in 2009. Each experiment should have prepared a computing TDR two years before the first beam.

The approach of a late decision on the specific technologies and methods in a rapidly developing field such as IT seems reasonable. Nevertheless, it is also mandatory to obtain for resource planning purposes an estimate of the costs expected for this activity already now at the outset of the construction of FAIR. This request was also made with emphasis by the FAIR International Steering Committee.

In order to estimate the computing resources required for FAIR the numbers from the LHC experiments were scaled accordingly. The first standard data taking year for PANDA will be 2014. It will have approximately the same computing requirements as one of the proton-proton experiments of LHC in 2008 (about the same recording rate and half a year beam time). The first standard data taking year for CBM will be 2015. The data rate is similar to ALICE, but three month of beam time per year is anticipated. ALICE will run only one month per year in heavy ion mode. Therefore the estimate of the needed CBM resources in 2015 is twice as large as ALICE in 2008; in 2014 CBM will need about half of that. To take the other FAIR experiments into account, we assume that together they need about 1/3 of the combined computing power of PANDA and CBM.

It was estimated that in the year 2014 about 108 SpecInt 2000 will be required, which will be ca. 1200 CPUs. Additionally 37 Petabyte of disk space and 33 Petabyte of tertiary storage will be needed. The tertiary storage will have to grow by the same amount during every year of operation. Computers and disks will have to be replaced every three years on average. The enhanced capabilities and performance of the replacement should account for the expected increase of computing needs.

Based on these estimates a ramp-up scenario from 2006 to 2014 can be set up. With an initial start of about 0.2% of the final capacity and doubling of the overall computing resources approximately every year the final configuration can be reached. Due to the Moore factor of about 1.45 this leads to a budget profile which requires a factor of 1.45 increase per year on average (see Table 3.2). The resulting annual performance seems to be in line with the simulation needs of the experiments, but must of course be fine tuned on a year to year basis. The gradual ramp-up of the resources is as well important for the IT department, to learn to cope with the growing complexity of the computing environment. The needed manpower to operate the IT department has been included in the section on operating costs (section 7.11).

Table 3.2: Initial estimate of the needed investment cost to build-up the required computing infrastructure for FAIR.

	2007	2008	2009	2010	2011	2012	2013	2014	Sum
CPU (rackmounted) [k€]	178	205	339	644	740	1039	2130	2448	7723
Disks (RAID) [k€]	110	126	209	397	456	641	1314	1216	4469
Archive (Tape) [k€]	99	135	186	321	444	612	1056	1455	4308
Sum	387	466	734	1362	1640	2292	4500	5119	16500

4. Civil Engineering

The FAIR complex will be constructed to the east of the existing GSI facility. The project will use the existing accelerator as an injector. The ring tunnel will be built in a cut and cover method and will be filled with about 10 m overlay of compacted soil. This conforms to the requirements from radiation safety. The method for constructing the ring tunnel takes into account the findings in geodetics and hydrogeology.

The removed soil will be recycled for shielding purposes and for terrain modelling of the new facility. This includes the necessary shielding for radiation safety. Three buildings located symmetrically will contain the access and supply labyrinths around the large synchrotron tunnel.

All other buildings will be arranged south of the large ring tunnel. Due to the large floor space involved, above-ground solution is considered because it is more economical. Construction of the above-ground buildings will require clearing of at most 14 hectares of forest that will be recultivated or be compensated for at other locations. Several topology versions were studied and the corresponding ion optics computed, analyzed and evaluated. Relevant aspects concerning the accelerators, experiments, safety and last but not least civil engineering have been taken into account.

For civil engineering, a number of factors had to be taken into consideration. Legal and regulatory procedures for construction planning needed to focus on procedural steps, development plan authorization and environmental impact studies. This process was carried out with the help of consulting companies in close collaboration with the local city and state authorities.

Planning included the regional and commercial Development Plan and nature compensation measures

(revegetation / reforestation). Civil engineering in FAIR covers the supply systems and installations, electric power supply system, crane facilities and the building constructions.

The topology of the facility was adapted (up to June 2006) to information from the planned experiments. Particularly the beam lines had to be changed to meet the new requirements, in some cases new structures were added. Existing buildings will be used to house FAIR facilities such as cryogenics, testing, storage and clearance area etc. All buildings and structures were further specified in more detail by the users. New building plans for each building were drawn. The accesses to the buildings, such as gateways, labyrinth passages, elevators, normal doors, are described in Volume 6 of this Baseline Technical Report. The civil engineering group consulted with the radio-protection group of GSI in matters of shielding.

The legal and regulatory procedure for the development plan (Bebauungsplanverfahren) has been successfully completed. Corresponding statutory decisions were taken by the town governmental authorities required for approval: Darmstadt City Council on February 14, 2006 and the regional authority of the State of Hessen (Regierungspräsidium Darmstadt/Südhessen) on May 12, 2005. The complex procedure started in May 2003 and could be settled within less than 3 years. This was a major step towards preparing the actual civil construction of the FAIR project.

The site covered by the building development plan is shown in Fig. 4.1 together with the civil construction planning for the FAIR facility.

1	Extraction Building
2	Injection Building
3	Emergency Exit
4	Transfer Building
4a	Transfer - Supply
6	Super - FRS
6a	Super - FRS Supply
6b	Super - FRS LE - Branch
6c	P-bar - Target
6d	P-bar - Target Supply
7	CR / RESR
7a	CR / RESR Supply
7b	CR / RESR High Building
8	NESR
8a	NESR Supply
8b	NESR - Preparation
9	HESR PANDA Detector
10	HESR - Cooler
10a	HESR - Cooler Tower
11	HESR Supply
12	PP
12a	PP/HEBT Supply & LASER
13	HESR Future Extension
14	NC (CBM)
14a	NC (CBM) Supply
15	HEAP
15a	HEAP Supply
16	LEAP Supply
17	Main Supply Building
17a	Compressor Building
18	Super - FRS Targethalle
19	Office Building
20	P - Linac
20a	P - Linac Supply
101	SIS18 - Transfer
102	Transfer Injection SIS100
103	Super - FRS
104	Transfer SIS100/300 - Exp.
105	Transfer SIS18 - PP
106	Transfer CR/RESR - HESR
107	HESR - Injection
108	HESR
110	SIS100/300 Tunnel
111	Extraction SIS100/300
112	Transfer CBM-Cave

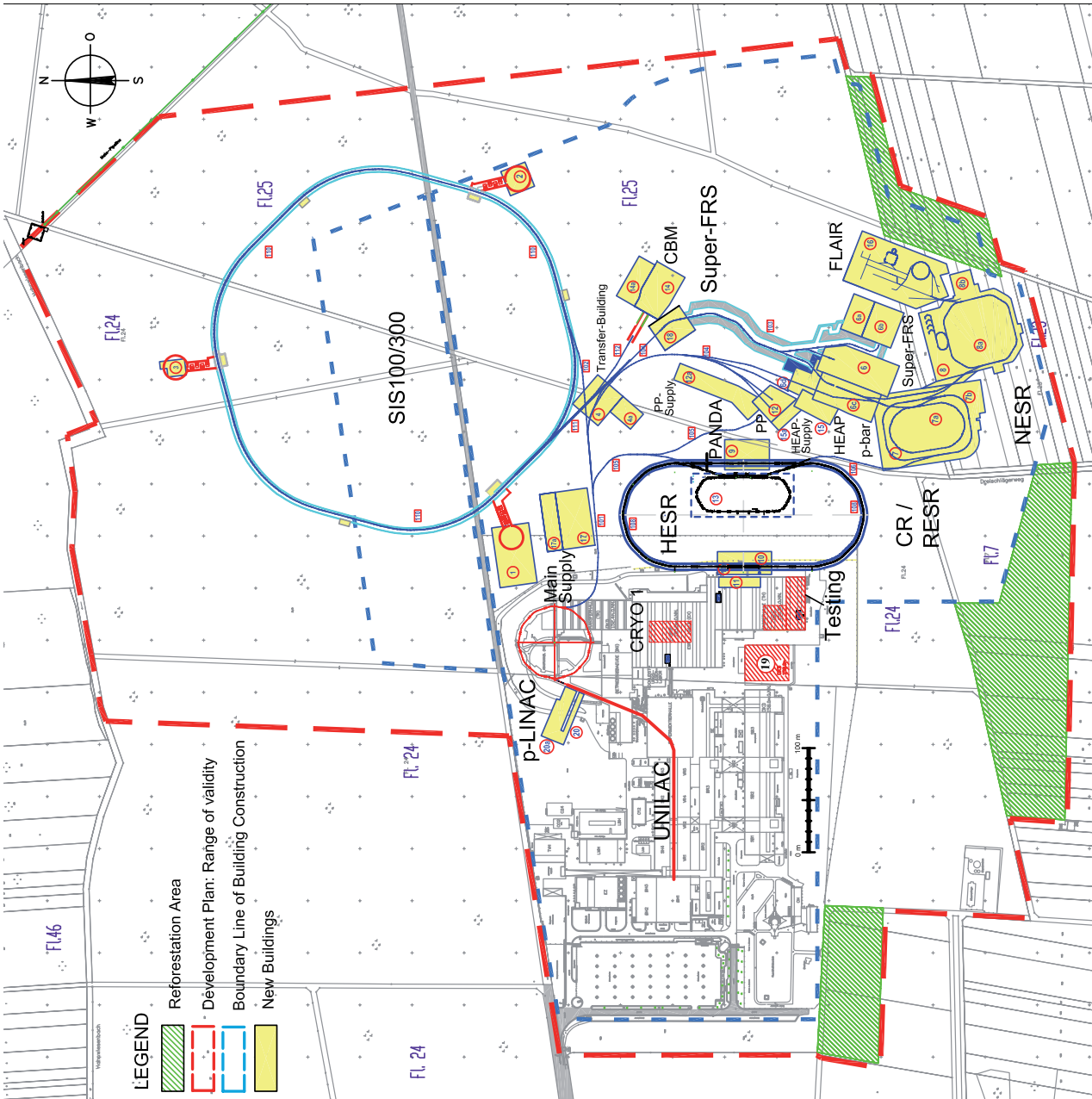

Figure 4.1: Site map of the future FAIR research facility. The existing GSI facility is shown in gray. UNILAC and SIS18 (red) inject into the new FAIR accelerator facility (blue) with the SIS100/300 synchrotron and the adjacent storage rings and experimental stations. The buildings housing the storage rings and experiments are shown in yellow. The dashed red line indicates the valid area of the development plan, the dashed blue line is the boundary line of building construction.

5. Radiation Safety Aspects

Radiation safety aspects had a major impact on civil construction planning for the FAIR facility, due to the shielding measures that are to be taken for operating the accelerators and experiments. Furthermore, the technical control-interlock-system as well as the organizational structure concerning safety aspects at FAIR is largely determined by the guidelines for radiation safety.

5.1 Radiation Safety Requirements

In the following the focus is on shielding aspects and radiation protection measures arising from the emission of radio-nuclides. For other issues, such as the technical control-interlock-system, radiation surveys, organizational issues, see Volume 6 of this Baseline Technical Report.

The FAIR Facilities must meet the conditions stipulated by the German radiation protection legislation:

- (i) Radiation emerging directly from the facility must not exceed a level of 0.7 to 1 mSv per year (8760 h).
- (ii) Radiation exposure by the emission of radio-nuclides must not exceed a level of 0.3 mSv per year.
- (iii) The sum of i. and ii. must be below 1 mSv (§46 StrlSchV, the German radiation protection ordinance).

- (iv) The radiation exposure (outside the radiation controlled areas) must not exceed a level of 6 mSv per year (2000 h) on the institute premises and of 1 mSv/a outside the premises.

Based on the layout presented in the Conceptual Report, a preliminary application for construction and operation of the FAIR facility was sent to the Hessian Ministry for Environment (HMULV) in Wiesbaden in early 2003, in compliance with § 11 and 13 of the German radiation protection ordinance. In December 2003, HMULV communicated a provisional decision to GSI with the conclusion that from the material submitted 'FAIR will comply with the stipulations of German Radiation Protection Law'.

The provisional decision did not include the permission for the construction and operation of FAIR. This permission has to be applied for each single accelerator and experimental subproject. The application procedure requires an expert's evaluation for each of those sections. Based on the expert's report, the HMULV formulates a permission for the section under consideration, or additional safety requirements may be requested.

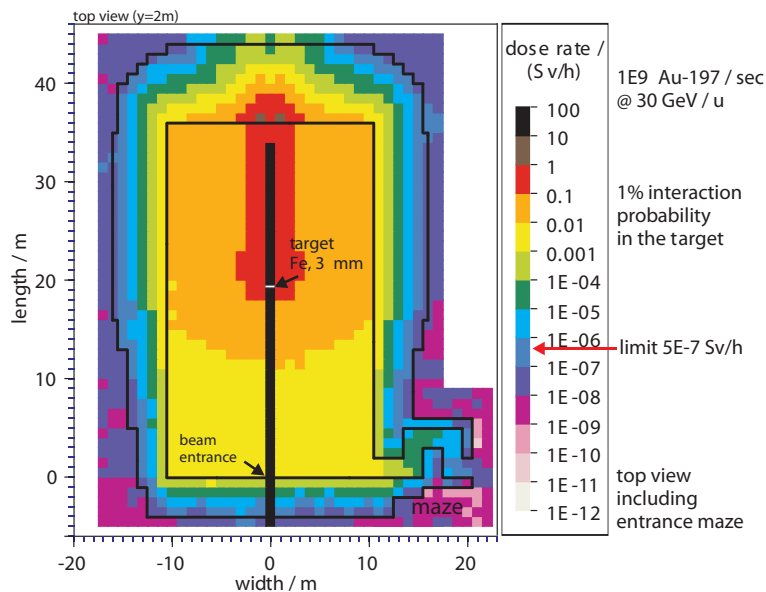

Figure 5.1: Dose pattern for the CBM Cave calculated under the conditions: a gold beam enters from below with energy 30 GeV/u and an intensity of 10^9 ions per second and hits a target causing an interacting rate of 1% of the primary beam and a deposition of 99% of the beam in a dump area behind the experimental cave (not shown). The black outline shows the contour of the concrete shielding.

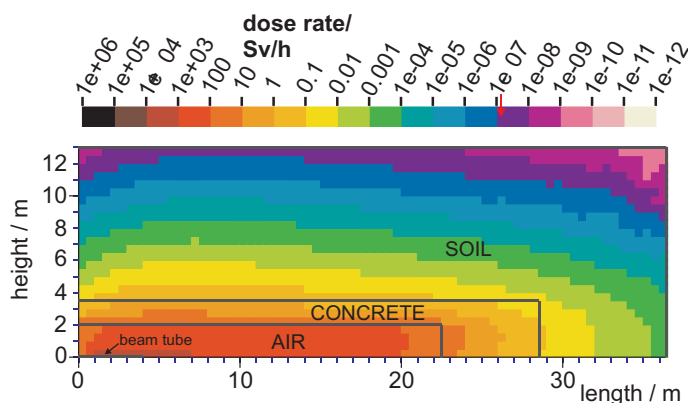

Figure 5.2: Dose pattern in the SIS100/300 tunnel. The dose rate at ground level must stay below $0.08 \mu\text{Sv/h}$. The calculation are based on the assumption that up to 10^{11} uranium atoms are lost every second and are resulting in a requested shielding of 1.5 m of concrete and 9.5 m of soil.

5.2 The Radiation Shielding Plan for FAIR

The radiation shielding plan for FAIR is based on detailed calculations of the production, transport and attenuation of radiation at the various components of the FAIR facility. Basically two approaches were pursued:

- the Moyer- or line-of-sight model (inverse square law and an exponential decrease of the dose in the shielding material); this method is less accurate but most efficient for simple geometries - like bulk shielding.
- Monte Carlo techniques to simulate the generation of radiation and the transport through the shielding; this method is more precise and well-suited for complex geometries e.g. in experimental stations.

As an example, Fig. 5.1 shows the shielding design for the experimental cave for the Condensed Baryonic Matter (CBM) experiment which was developed using the radiation transport code FLUKA (www.fluka.org). The results shown refer to a gold beam with 30 GeV/u, an intensity of 10^9 ions per second, a target causing an interacting rate of 1% of the primary beam and a deposition of 99% of the beam in a dump area behind the experimental cave. The concrete shielding was designed to ensure a radiation level lower than $3 \mu\text{Sv/h}$ (computation has a dose level of $0.5 \mu\text{Sv/h}$ outside the cave).

Another example is the shielding of the underground SIS100/300 tunnel. The tunnel itself consists of concrete walls with a thickness of 1.5 m. The walls, together with the soil layer of 9.5 m thickness attenuate the radiation down to the required level of 80 nSv/h ($=0.7 \text{ mSv}/8760 \text{ h}$). Fig. 5.2 shows the results for a uranium beam (1.5 GeV/u) with a total loss rate of 10^{11} ions/sec.

5.3 Radiation Protection Concerning the Emission of Radio-Nuclides

The operation of FAIR may not cause emission of radio-nuclides into the environment. Two radiological paths are to be considered, activation of air and of soil (ground water), respectively. Activation of air occurs mainly in the target areas of FAIR and in the tunnel of SIS 100/300. It can effect the emission of radio-nuclides (e.g. 11-C; 32,33-P; 7-Be; 38,39-Cl) which gives source terms for radiation exposure mainly by incorporation (respiration), by gamma submersion and by the deposition of radio-nuclides in the surrounding farmland and consequently the potential insertion of these in the food chain. Furthermore, activation of soil and ground water can cause an exposure by ingestion of drinking water (radio-nuclides 3-H; 7-Be; 22-Na; 45-Ca). The radiation exposure by all these radiological paths has to be limited according to §46, 47 of the radiation protection ordinance (StrlSchV) to 0.3 mSv effective dose per year.

Model calculations were applied using FLUKA. The radio-nuclide production in air was calculated and their transport in air was computed by the use of the simulation program BSAVVL (www.brenk.com). The latter was developed in accordance with the guidelines of the AVV (German administrative regulation for dose assessment for radio-nuclide emission of nuclear installations). As a result of these simulations, it was deemed necessary to install retention systems for the aerosol-borne radioactivity to reduce the emission of the air-borne radioactivity.

With respect to radiation exposure by ingestion of drinking water (caused by radio-nuclide transport via groundwater) it was found that the solubility of the radio-nuclides in question is too low to cause a problem. The limits set by the radiation protection ordinance (§ 47 StrlSchV) will, therefore, be clearly met.

6. Organisation of FAIR as International Project

For the preparatory phase of FAIR, a Memorandum of Understanding (MoU) has been signed by representatives of 13 countries. The MoU provides the basis for the international co-operation during the period 2004 to 2006. All preparatory activities during that phase were coordinated by the FAIR International Steering Committee (ISC), which consists of one representative of each of the signatories of the MoU. The ISC agreed that a set of documents should be provided by spring 2006, on scientific-technical issues on the one hand and administrative-financial issues on the other, in order to come to a decision on the construction and operation of FAIR in an international context. This Baseline Technical Report is a central part of those documents.

6.1 International Steering Committee (ISC)

Based on the initiative of the Federal Ministry for Education and Research (BMBF), an international steering committee was established in February 2004. The mandate of the ISC is to coordinate and to accompany the preparatory phase of the FAIR project in all scientific-technical and administrative-financial issues (Fig. 6.1).

The ISC is made up of representatives from ministries and funding agencies of, so far, 13 partner countries: China,

Finland, France, Germany, Greece, India, Italy, Poland, Romania, Russia, Spain, Sweden, United Kingdom. These countries have signed the FAIR Memorandum of Understanding, thereby expressing their intention to contribute to the construction of FAIR and to co-operate during the preparatory phase. Representatives from Austria, Hungary, USA and from the European Commission take part in the ISC meetings as observers.

The ISC has formed two working groups: the working group for scientific and technical issues (STI) and the working group for administrative and funding issues (AFI). (For current membership of the ISC, STI and AFI see the Appendix.)

6.2 Working Group on Scientific and Technical Issues (STI)

The mandate of STI is to evaluate and define the scientific program planned at FAIR as well as the layout and technical design of the facility.

Specifically, the mandate of the STI working group includes:

- Definition of the scientific program (base program plus options) at FAIR and selection of the respective experiments;

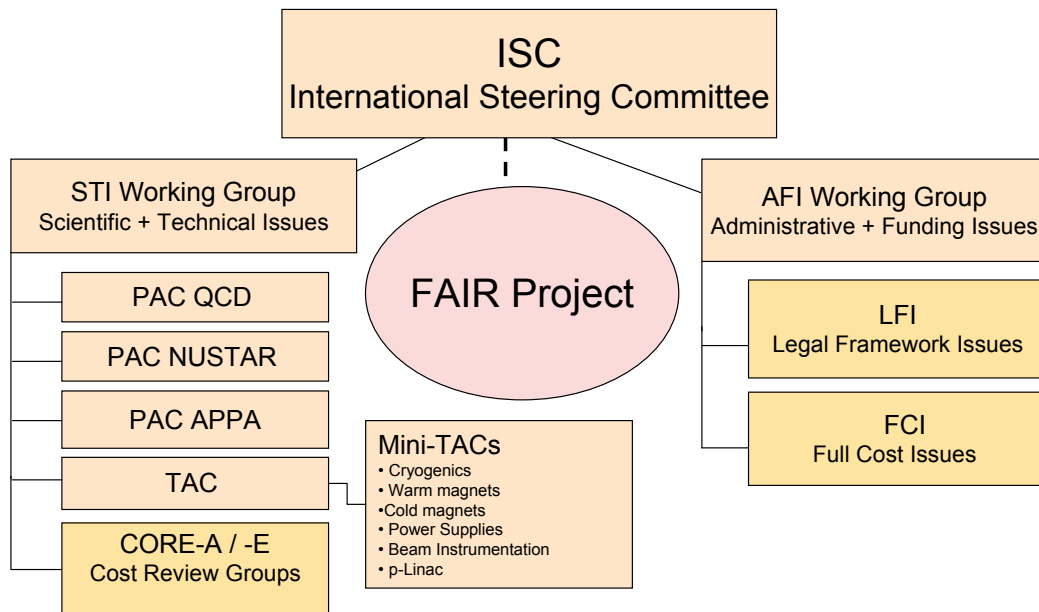

Figure 6.1: The current international committee structure for the FAIR project.

- Definition of the layout and technical design of FAIR;
- Evaluation of costs for constructing and operating the FAIR facility (accelerators, civil construction and experiments)
- Definition of a time schedule for constructing, commissioning, and starting the experimental programs at the FAIR facility
- Preparation of documents regarding the above issues

STI has formed three Program Advisory Committees (PACs) for the scientific areas: QCD & hadronic matter physics (PAC QCD); nuclear structure and astrophysics (PAC NUSTAR); atomic physics, plasma physics and applied research (PAC APPA) as well as a Technical Advisory Committee (TAC) for accelerator issues. Besides the TAC, a number of mini-TACs have been formed to study in detail specific accelerator aspects. Moreover, two working groups have been formed to evaluate the cost estimates and potential risks with respect to the proposed accelerators (Cost Review A) and experiments (Cost Review E). (The membership in these sub working groups is listed in the Appendix.)

Status Report of the STI-Activites (September 2006):

Definition of the scientific program: The research programs outlined in the CDR were solicited and developed further within the framework of a call for Letters of Intent (LoIs) in spring 2004, a LoI evaluation by the PACs during summer 2004, and a subsequent call for Technical Proposals in January 2005. The latter were evaluated during the period March 2005 - June 2005. Based on the recommendations by the PACs, STI defined in September 2005 which experiments should be included in the Core Facility and be funded during the construction period of FAIR. The list is given in Table 6.1.

The Volumes of the present Baseline Technical Report which deal with experimental facilities (Vols 3A, 3B, 4, and 5) have been worked out incorporating the findings of the evaluation of the Letters of Intent and the Technical Proposals by PAC and STI.

Definition of the layout and technical design of FAIR: Parallel to the Technical Proposals submitted by the experimental collaborations, a Technical Report (TR) was prepared for the accelerator part of the FAIR facility. Compared to the original CDR, this TR already contained substantial extensions such as SIS300 instead of SIS200 and operational considerations, like adding an RESR to the accelerator complex, thus taking away from the NESR

the double load of heavy-ion experiments and cooling of antiprotons. During 2005, the TR was thoroughly scrutinized by the TAC. Special classes of items, which will account for considerable parts of the budget, were reviewed by dedicated mini-TACs in order to ensure the best possible value-for-money ratio without losing physics performance. This included taking into account buildings, tunnels, and radiation protection measures. The Cost Review group A (CORE-A) was closely involved in this process, and joint meetings of CORE-A and TAC took place. As a result of this evaluation process, several parts of the Technical Report, including the topological layout of the whole facility and the specification of some of the rings were considerably reworked. The Baseline-Technical Report contains the optimized topology for the accelerator facility (see Volume 2).

Cost review of the experimental facilities by CORE-E:

After the presentation of the Technical Proposals by the experimental collaborations and their evaluation by the PACs in spring 2005, CORE-E scrutinized the costs of most experiments during summer 2005. Corrections of the estimated construction costs were made in several cases and are included in the costs specified in the cost book for the experiments. The cost evaluation was done according to the following "Terms of Reference:"

1. CORE-E reviewed the cost estimates for the experiments at the FAIR facility in Darmstadt and assessed the manpower requirements for the construction of the experiments. CORE-E was not concerned with funding.
2. The experiments were in an early stage of design with correspondingly large uncertainties in the detector configuration. Cost estimates were therefore based on a model design. A major issue of the evaluation was the task to search for forgotten items which could turn out to be costly.
3. It was assumed that the experimental areas will come equipped with power, air conditioning, cranes, cooling water, liquid helium transfer lines, general fire safety and shielding against the machines. The experiments have to provide, and are responsible for, all connections from the "wall" of the experiment hall or cave to the experiment.
4. The experiments have to allocate funds for crane operators, local cooling, rails and handling tools for heavy equipment, local safety (flammable gases, fire protection for electronic racks), local shielding.
5. Experiment-specific modifications to the basic machines will be costed as part of the experiment. Beam pipes through the experiment are an example.

These Terms of Reference are analogous to similar rules for the LHC at CERN.

The cost estimates should include or consider:

- material cost
- engineering design
- construction
- commissioning
- electronics and DAQ
- number of spares
- cost for prototyping and tests
- calibration, if extra money is requested for e.g. a test beam set up
- safety (flammable gases, fire protection in electronic racks)
- installation including transport and survey.

In addition following considerations should apply:

- institutional manpower is not costed, the manpower in man years associated with each project should, however, be given
- cost for hired manpower
- R & D is often financed from budgets, which are separated from the experiment cost. These costs should not be included. If R & D money has to come out of the experiment's budget, it must be included in the costing.
- normally the infrastructure at the participating institutes comes free of charge. If, however, major installations for tests or assembly have to be paid by the collaboration, this money may be included.
- a first guess for the maintenance and operation cost should be given

All the conditional costs just described must be approved by the Experiment Board.

CORE-E made an attempt to estimate possible risks in costing the experiments and has assigned an uncertainty to each experiment. These estimates are very rough and ad hoc. They are based on previous experience, in particular from the LHC experiments at CERN and other recently built facilities. They should only be used as a guideline and it should be kept in mind that the experiments are at an early stage. This applies in particular to the risk estimates related to lacking manpower. Here it is assumed that at least some of the lacking manpower will become available, thus, optimistic assumptions have been made. However, as the collaborating institutes are mainly university groups, much of the manpower might be acquired cost effectively, e.g. as graduate students.

Cost review of accelerator facility and buildings by CORE-A: During summer and autumn 2005, CORE-A scrutinized the costs specified in the Technical Report for the accelerator facility in close cooperation with STI, TAC and the mini-TACs. The goal was to establish

a reliable cost estimate within a reasonable planning for the facility leading to the best possible value-for-money solution. The costs specified for the accelerator facility are the result of this process.

In order to carry out a thorough and efficient review, CORE-A chose to analyse the FAIR Project costs in terms of the different types of components (e.g. warm magnets, superconducting magnets, vacuum, radio-frequency components, controls, etc.) rather than on an accelerator-by-accelerator basis. A major issue of the CORE-A evaluation was the search for forgotten items.

For some elements vendor quotations or catalogue prices are available. Many other cost estimates are based on previous experience with the construction of accelerators at GSI and elsewhere. While the cost of large systems similar to existing ones can be determined with good accuracy, the costs for very advanced components which have never been built before and for components produced in small numbers are much less certain. This is indicated in the uncertainty margins.

CORE-A strongly recommends that a policy be defined for the purchase of spares and risk management which is consistent with an efficient operation of the FAIR facilities.

Both cost reviews performed by CORE-E and CORE-A followed certain rules defined by a different working group on full costing issues (FCI) and agreed upon by both AFI and STI (see 6.3). The costs specified in this Baseline Technical Report were estimated employing those rules.

6.3 Working Group on Administrative and Funding Issues (AFI)

The mandate of the AFI working group is:

- to investigate (and propose to the ISC-FAIR) possible legal structures for the construction and operation of FAIR. For the preparation of a convention and the corresponding articles of association for such a legal structure, AFI has formed a working group on legal frame issues (AFI-LFI);
- to prepare a Memorandum of Understanding (MoU) as a formal basis for cooperation during the preparatory phase until (legal) contracts between the FAIR partners will be made. As mentioned above, this MoU has been signed by 13 countries so far (see also Appendix);
- to prepare model contracts for contributions to be made by the partner countries for the construction of FAIR; in that connection a further working group on

Table 6.1: STI recommendations on experiments based on PAC findings. "PAC" indicates the respective Program Advisory Committee; "Base Program" means whether the experiment had been part of the original CDR, and "Core Facility" points out whether the experiment should be included into the FAIR construction and correspondingly funded.

Experiment	PAC	Base Program	Core Facility	Comments
R3B	NUSTAR	yes	yes	Only phase one is accepted
HISPEC/DESPEC	NUSTAR	yes	yes	
ILIMA	NUSTAR	yes	yes	
LASPEC	NUSTAR	yes	yes	
MATS	NUSTAR	yes	yes	
AIC	NUSTAR	no	no	open scientific and technical issues
ELISe	NUSTAR	yes	yes	
EXL	NUSTAR	yes	yes	
NCAP	NUSTAR	no	no	request only beam-time
EXO-pbar	NUSTAR	no	no	
PANDA	QCD	yes	yes	
CBM	QCD	yes	yes	
PAX	QCD	no	no	Strong scientific merit; could become part of core facility
ASSIA	QCD	no	no	Consider joining PAX
HEDgeHOB/WDM	APPA	yes	yes	should merge under one umbrella
FLAIR	APPA	no	yes	not part of the initial CDR
SPARC	APPA	yes	yes	
BIOMAT	APPA	yes	yes	

full costing issues has been formed (AFI-FCI); its task is to prepare a general costing scheme on how to account costs for construction, operation, and personnel and how to take into account additional costs due to indexation, management, controlling, etc.

The membership of the AFI-LCI and the AFI-FCI working groups is listed in the Appendix.

Status Report of the AFI-Activities (September 2006)

Legal Structure of FAIR: AFI and the AFI subgroups have worked out all necessary documents for the legal establishment of FAIR. This includes also a Governance model which will serve as the basis for the organization and execution of the FAIR Project. Major features will be:

- The FAIR Convention as an international treaty governed by international public law,
- The FAIR Final Act as governmental agreement, allowing start up of FAIR prior to ratification of the Convention,
- The Articles of Association of FAIR GmbH, governed by German private law, serving as statutes of FAIR GmbH,
- A set of by-laws regulating the internal relationship between FAIR GmbH shareholders and basic principles of FAIR GmbH, such as staff rules, financial rules including purchasing rules and rules of procedures of different organs and committees.
- The definition of the relationship and cooperation between FAIR GmbH and GSI mbH (business management contract).

Details have to be negotiated between the partner countries which is not an integral part of this Baseline Technical Report. We will therefore confine ourselves in the following to a brief outline of the present considerations regarding this issue. The legal framework will be the FAIR Convention, signed by all participating member states. The Convention as an international treaty contains in particular basic principles on the governance structure (foundation of FAIR GmbH), the commitment to support the FAIR GmbH shareholders and the definition of the costs and contributions.

FAIR will be organized as a Limited Liability Company according to German Law (GmbH, "Gesellschaft mit beschränkter Haftung, www.gmbH-gesetz.de). Shareholders are to be nominated by the Contracting Parties of the Convention under which FAIR GmbH will be set up.

The FAIR Convention shall be valid for an initial time of ten years of operation after completion of the construction phase. The company will have as organs the shareholders' assembly, termed Council, and the Managing Directors. The Managing Directors report to the Council.

The share capital of the FAIR GmbH will be 25,000 €, consisting of 500 shares worth 50 € each. It is intended that each shareholder holds a minimum of five shares. The relation of shares in the share capital will be linked to the shareholders' contributions towards the cost for construction and operation. For the construction of specific FAIR parts, the FAIR GmbH will close contracts with the collaborating institutions, be they in-kind contribution or services.

Relation between FAIR GmbH and GSI mbH: For the construction and operation of FAIR, FAIR GmbH will cooperate closely with GSI on a contractual basis as with all other participating institutions. In this way, optimal use shall be made of the know-how and experience existing at GSI. Dual structures with respect to FAIR GmbH and GSI mbH are to be avoided, and tasks between both companies are to be defined clearly. An attractive legal frame could be the conclusion of a contract for services, in the sense of a business management contract, under which GSI mbH would act for FAIR GmbH by virtue of general power of attorney granted to it. This would also allow adopting permits already obtained by GSI for planning, construction, and safety issues and would permit the beginning of construction without undue delay.

Further details will be stipulated in the Convention, Articles of Association, and the By-Laws under which the FAIR GmbH will be set up.

General Costing Scheme proposed by FCI and AFI: The general methodology for costing has been worked out by the AFI sub-group on Full Cost Issues. A Final Report was issued as an independent document from this group on the methodology of accounting costs for construction, operation, and personnel as well as on indexation, handling of risks and management and controlling. Essential findings were:

- Operation costs for the FAIR Accelerator facility are estimated to be 118 million € per year (2005 prices) for the accelerator facility (including media supply for the experiments and infrastructure costs such as workshops, canteen, etc).
- Operation costs for the 18 experiments are difficult to estimate at this point in time where several choices for detectors are still pending for several years of R&D. However, based on experience from experiments at GSI (HADES, FOPI) and at CERN (NA49, WA98) a sum of 7 million € per year would cover the operation costs for all the 18 experiments together (excluding upgrades).
- Costs for commissioning are to be included into the construction cost. End of commissioning and hence start of operation has been defined by reaching certain beam parameters.
- Decommissioning should be accounted for by two annual operation budgets. However, a firm commitment of one of the contracting parties to take over the facility after the end of operation could avoid such provisions.

- Personnel at the FAIR project execution is provisionally accounted for with 77,000 € per person and year (2005). The figure might change once the tariff structure of FAIR GmbH is established.
- Risk was properly accounted for in costing. A risk budget is recommended to be established for contributions paid in cash.
- Indexation is not to be considered in the specification of prices. An inflation rate of 2 % per year is recommended for estimating actual prices in the future but should not be included into any costing.
- In-kind contributions are to be dealt with along the corresponding Annex to the FAIR Convention.
- Controlling and Management tools at GSI following the "Guidelines for Controlling Large-Scale Projects" issued by BMBF seem convincing and should be adopted.
- For the calculation of construction costs, the following rules are recommended:
 - The manpower and financial resources needed for each subproject are grouped into three headings:
 - (i) R&D and prototyping on the various subprojects;
 - (ii) costs for infrastructure in the institutes, and costs for personnel, travel, etc. of the institutes, as arising from their participation in a FAIR experiment collaboration or a FAIR consortium;
 - (iii) engineering design, final pre-production prototyping, manufacturing, calibration, transportation, assembly, installation and commissioning costs for each subproject.
 - The resources needed for work under the headings (i) and (ii) are the responsibility of the institutes supported by their respective Funding Agencies. These resources are neither accounted for in construction costs, nor monitored centrally by the FAIR company.
 - The resources needed for work under the heading (iii) cover the costs of each subproject. These costs have been evaluated by the FAIR collaboration and verified by CORE. Only these costs are monitored centrally by the FAIR company.
 - The value of a subproject is defined by the CORE group.
 - For selected subprojects with high risk, a "risk budget" has to be implemented. These high risk subprojects are yet to be identified by the FAIR project and confirmed by CORE. The risk budget will be monitored by the FAIR Project Management and controlled by the Resources-Review Board (RRB) of the FAIR GmbH Member countries.
 - The manpower estimates of institutes / consortia who have the intention of carrying out a particular subproject is evaluated by CORE.

7. Costs and Schedule

7.1 Overview

This chapter summarizes the estimated total construction, commissioning and operating costs for FAIR. The construction costs are divided into four categories: investment costs for civil construction, accelerators, and experimental equipment and manpower costs. The latter depends critically on total effort but also on schedule, which is also presented in this chapter. The summary costs reported here are based on detailed calculations and component estimates as described in Volume 2 of the BTR (accelerators), Volumes 3-5 (experiments), Volume 6 (civil construction) and the Cost Book with more than 5000 entries. These costs were reviewed by a thorough process involving the technical, scientific and cost review committees described in section 6.

Civil construction costs were determined by the BUNG engineering company ('Bung Beratende Ingenieure') from Heidelberg, based on information provided to them from the FAIR project, specifying buildings and their detailed uses. BUNG worked out a detailed technical study for all individual buildings and the ring tunnels and performed respective cost analyses. The infrastructure costs were determined by GSI's technical and accelerator experts, based on infrastructure costs incurred with the previous SIS/ESR facility construction and scaled to both, today's cost level (taking into account inflation) and to the physical and operational dimensions of the respective units for FAIR.

Costs of the accelerator system were determined along a work breakdown structure (WBS) up to level 5. This resulted in more than 5000 subtasks that were further studied for detailed design and with respect to costs. Thus costs for the accelerator systems were first obtained on a component basis, and then aggregated to sub-unit costs, such as for accelerator rings etc. Component cost were scrutinized by the Technical Advisory Committee TAC with the help of expert groups (mini-TACs) that reviewed specific technical areas, such as beam diagnostics, cryogenics, power converters, warm and cold magnets etc. (See the list of mini-TACs and their respective memberships in the Appendix). In addition to establishing reliable cost, the expert groups were asked to help minimize costs. The resulting expert comments and suggestions were incorporated into the detailed technical sections of this BTR. The costs of components and sub-system work packages, altogether more than 5000 items, are summarized in the Cost Book (Rev. 3.0) that is prepared together with this BTR.

In addition, an independent Cost Review Committee on Accelerators (CORE-A) was implemented by the STI working group. Besides scrutinizing costs and determining risk factors, a key task for CORE-A was the identification of potentially missing items. All this information was used in the preparation of the BTR as it is presented here. The report of the CORE-A group has been presented to the STI.

Costs were also determined for the experimental equipment and major detectors based on the Technical Reports for the experimental programs. Approval of the experiments by the Program Advisory Committees (PACs) involved, in addition to the primary task of identifying important science, scrutiny of technical realization and performance and minimization of costs. In line with the original CDR, and after identifying the core research program, the necessary baseline equipment was identified and baseline costs established for the experimental program. The list of items included in the category of baseline costs is given in the Cost Book. The list takes into account the fact that the experimental program is dynamic and constantly evolving and that many components from the experimental set-ups might be brought in from existing equipment pools and/or for transient uses at FAIR. Consequently, these are not considered baseline cost, neither are potential (transient) contributions to experimental campaigns from collaborators who come from institutes where the country is not an official partner of the FAIR facility.

As for the accelerators, an independent review of experiment costs was carried out by a CORE-E ('E' for experiments) review committee set up by STI. Again, as with the accelerators, all the information obtained in the review processes have entered the preparations of this BTR and the report of the CORE-E review committee was presented to STI.

The facility costs are summarized in the Cost Book. At this point in time, the Cost Book and thus its information is only for restricted and controlled distribution.

The Cost Book contains the information on the planned schedule for construction of FAIR. Since the construction is requested by the funding partners to proceed in three stages, with definite research capabilities available at the end of each stage, the discussion of schedule is closely tied into the aspects of cost and in particular of the cost profile. A summary of the aspects related to schedule and manpower is given below.

7.2 Costs of the Accelerator Complex

The FAIR accelerators and the technical systems they require are based predominantly on well established and proven technology available today. With respect to schedule and cost, this allows for a quick start, minimizes the project risk and provides for a solid cost basis.

The costs refer to the net investment cost, no VAT or other indirect costs as customs and duties are included. However, the cost of individual items from the working packages include delivery, costs for inspection, testing and installation as well as the minimum of spare parts, e.g. coils of magnets rather than complete magnets for exchange.

The project costs have been carefully scrutinized using a bottom-up approach on a single element basis. Following the Work Breakdown Structure (WBS), technical subsystems (TS) as listed in Volume 2 of the BTR were evaluated for each individual WBS-subproject.

For each accelerator intensive studies on the ion optical design, including tolerances were carried out. Relevant parameters were derived from the optics design, e.g. magnet dimensions, and a first design of components was performed as described in the Baseline Technical Report. From these findings technical subsystems were specified such as, for example, power converters etc; other examples are the local liquid He-distribution and cryogenics. All accelerator-related hardware required is listed in the Cost Book.

The total costs estimate for the accelerators amounts to 533.M€; costs for the individual subprojects are listed in Table 7.1; their fractional contribution to the total is illustrated in Figure 7.1.

Requirements arising from the technical subsystems were turned into space requirements which together with additional specifications of relevance to civil construction gave the input to BUNG Beratende Ingenieure, who costed tunnels, experimental halls and ancillary buildings for the accelerators and experiments.

7.3 Civil Construction Costs for Accelerator and Experimental Buildings

The cost evaluation for the civil construction subproject is based on a detailed study performed by BUNG Beratende Ingenieure, Heidelberg. BUNG has evaluated all 20 individual buildings. Figure 7.2 shows a birds-eye view of the topology of buildings on the FAIR/GSI site. The evaluation of the building costs follows close to DIN276. Including the necessary infrastructure for installation of accelerator components and the primary services such

Table 7.1: Cost breakdown according to accelerator subprojects.

Subproject	Cost (M€)
Accelerators	533.0
UNILAC Upgrade (not part of the project)	
SIS18 Upgrade (not part of the project)	
High-Energy Beam Transport HEBT	78.8
Super-FRS (part of experiment program)	
Collector Ring CR	37.9
New Experimental Storage Ring NESR	23.6
p-Linac	13.4
Synchrotron SIS100	82.1
p-bar Separator	4.5
Accumulator Ring RESR	20.8
High-Energy Storage Ring HESR	59.3
Synchrotron SIS300	96.0
Electron Ring ER	12.2
Common Systems (Acc)	104.4

as electrical power, gases and cooling water etc. in the experimental halls, the total cost is 288.7 M€.

7.4 Costs of the Construction of the Experiments

The cost for experiments comprises the experimental facilities as well as the Super Fragment Separator (Super-FRS). The Super-FRS is operationally part of the experimental facility and thus included in the sum for the baseline experimental facilities. Technically it belongs to accelerators and is therefore included in the accelerator Cost Book and was reviewed by CORE-A.

Costs for the experimental equipment and major detectors were determined on the basis of Technical Proposals for the experimental programs. Approval of the experiments by the program advisory committees (PACs) included, in addition to the primary task of identifying important science, scrutiny of technical realization, performance and minimization of costs.

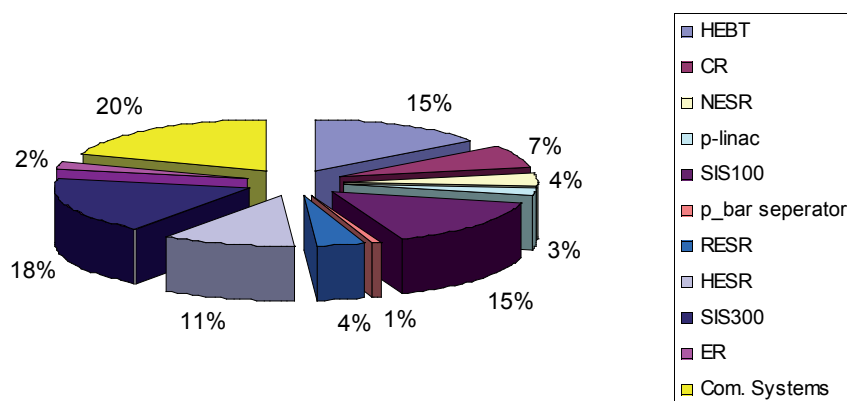

Figure 7.1: Cost distribution among the accelerator subprojects.

Based on recent developments in the research programs, the layout of the FAIR facilities has undergone some significant changes since the Conceptual Design Report in 2001. Changes included the upgrade of SIS-200 to SIS-300, an extension of the Super-FRS, the introduction of the additional storage ring RESR. These changes further increased the capabilities to have simultaneous operation of experiments as well as greater luminosities for some experiments. These changes significantly enhanced the discovery potential and scientific merit of experiments and was strongly endorsed or even proposed by the external advisory committees on accelerators and physics programs (TAC and PACs). The introduction of FLAIR (Facility for Low-energy Antiproton and Ion Research) opens a whole new physics domain that offers unique discovery potential.

FLAIR introduced additional costs for the FAIR infrastructure in the order of 10 M€. The corresponding experiments will be funded by third parties. Overall these changes multiplied the scientific potential of the FAIR facility at modest cost.

Additional experimental proposals have been submitted. Notably PAX and AIC would offer unique scientific opportunities. These experiments have been reviewed by CORE-E. Their costs are listed in the Cost Book, but are not included in the full cost of the FAIR Core facility. These experiments require intensive R&D and are considered future potential upgrades.

Some of the Letters of Intent of experiments that were submitted to the STI have not been included in the Cost Book. These experiments have been rejected by the PACs and the STI because of the lack of scientific merit or of insufficient technical design.

The costs for the experimental program are listed in the respective section of the Cost Book and map directly to the corresponding Volumes 3-5 of the FAIR Baseline

Technical Report. An independent review of experiment costs was carried out by the CORE-E review committee set up by the STI. As with the accelerators, all the information obtained in the review process have entered the preparations of the BTR.

The cost evaluation by the CORE committees did not address the question of financing. Its sole aim was to establish reliable cost estimates. As already mentioned, in the case of the experiments it was always assumed that a significant contribution from non-member states will be made. Physicists and institutes from non-member states constitute a significant fraction of the current and of the intended efforts at the FAIR experimental facilities. Thus, out of the 269 M€ cost for the construction of the full initial research program, a baseline experiment budget of 180 M€ is proposed as genuine FAIR facility contribution to the construction of the experimental facilities.

7.5 Total Construction Cost

Table 7.2 summarizes the results for the four cost categories and the total cost for FAIR. The total sum amounts to **1186,5 M€**. The costs for all required conventional buildings and the technical infrastructure to run the accelerators and experiments, studied by Bung Beratende Ingenieure, Heidelberg, and described in Volume 6 of the BTR, amount to 288,9 M€. Accelerator costs require an investment sum of 532,8 M€. For the first phase of experiments a budget of 180 M€ is foreseen, which includes the fragment separator Super-FRS. A total manpower of 2400 man-years has been identified to be required for the construction phase. This manpower corresponds to personnel costs of 184,8 M€ (see section 7.8). Total manpower costs depend primarily on total effort but to some extent also on schedule. The assumed schedule underlying our calculations is described in the following section.

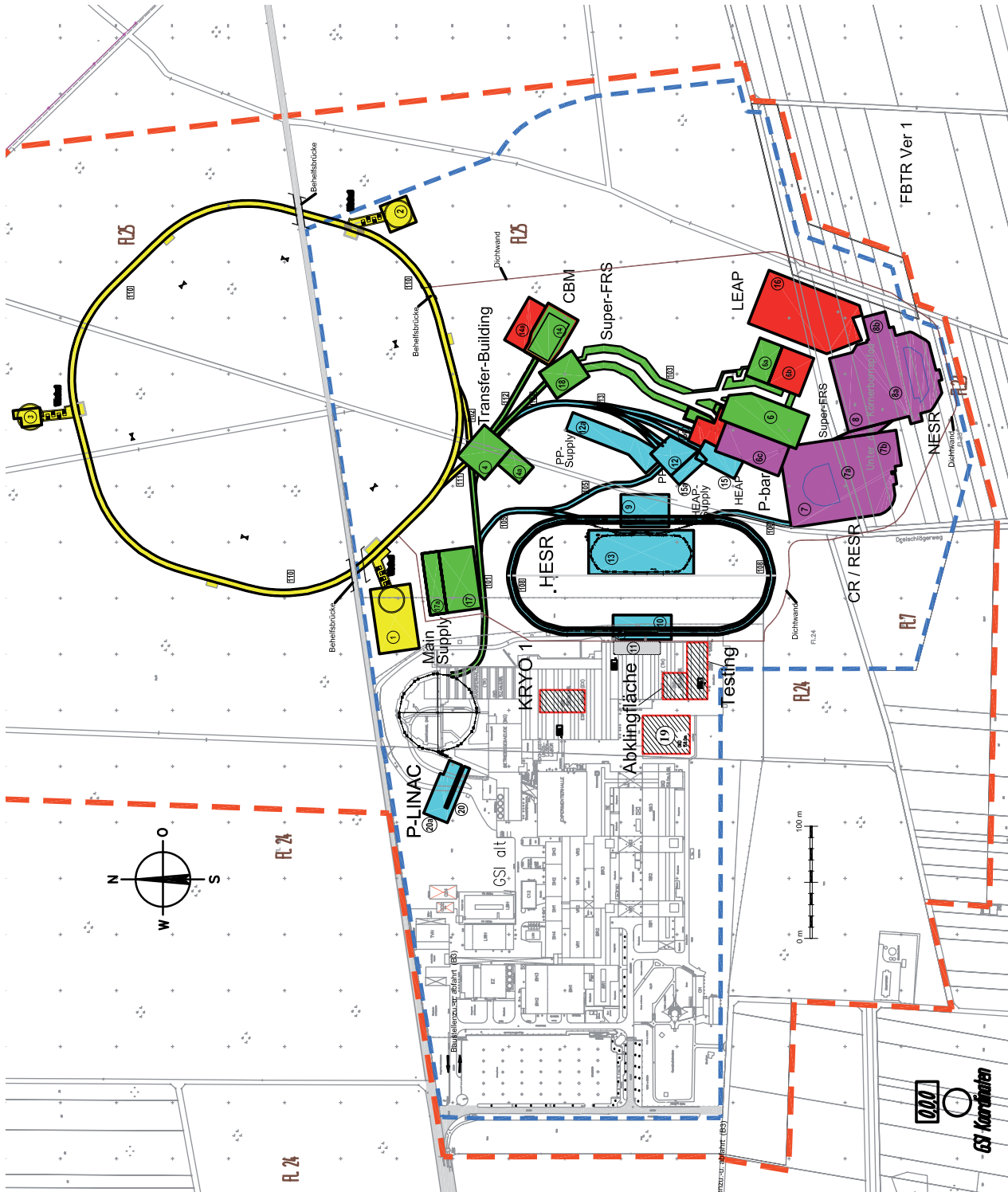

Figure 7.2: Color coded sequence of availability of buildings: Phase 1a (green) – ready for installation mid 2010; Phase 1b (yellow) – ready for installation mid 2010; Phase 1c (purple) – ready for installation end 2011; Phase 1d (red) – ready for installation in 2013

Table 7.2: Distribution of the project costs.

Sub Project	Costs M€
Total	1186.5
Accelerators	533.0
Civil Engineering	288.7
Experiments (incl. Super-FRS)	180.0
Manpower	184.8

7.6 Schedule

The total construction time for the FAIR facility will be 8 years. The project, following an original constraint of the government, is divided into three phases. These three phases reflect also the subsequent staging of different fields of science:

Stage 1: Radioactive beam physics

- Nuclear structure and nuclear astrophysics
- Atomic physics and plasma physics studies with highly charged and/or radioactive ions

Stage 2: Proton-antiproton physics and relativistic heavy ions

- QCD studies with protons and antiprotons
- Precision studies with antiproton beams addressing fundamental symmetries and interactions
- Dense baryonic matter physics using relativistic heavy ions at energies 1 – 10 GeV/u
- Atomic physics at relativistic energies

Stage 3: Full facility capability & all research programs

- Full parallel operation of up to four research programs
- Full energy and luminosity for nuclear collisions program
- Precision QCD Studies at PANDA
- Plasma research
- Atomic reaction studies with fast beams

The staging is reflected in the sequence of expected availability of buildings. The planning has been optimized with respect to minimizing construction costs and construction time. Alternatives are possible, may, however, be realized at higher costs only. Thus the proposed schedule, derived by Bung Beratende Ingenieure, was taken as the baseline for the present

planning of FAIR. The schedule assumes the start of planning for the building permit (Genehmigungsplanung) in January 2007.

The schedule for civil construction (Figure 7.3) shows that the tunnels for beam transport from SIS18 and all relevant buildings for operating the Super-FRS will be prepared for installation of accelerator components in mid 2010. As the tunnel for SIS100/SIS300 can be built in parallel it will be ready for occupancy in 2010 as well.

According to the present schedule construction phase 1c, which comprises the halls for CR, RESR and NESR rings with ancillary buildings, will be available for technical installations around the beginning of 2012. Finally, HESR installation can start in 2013.

This sequence in building activities is indicated in figure 7.3 with the different construction phases marked in different colors.

Based on these dates, the schedule for installation of accelerator components is derived, leading to the overall time schedule shown in Figure 7.3.

The schedule displays information for the storage rings and synchrotrons: a period of 10 to 12 months is needed for installation of accelerator components such as magnets, vacuum chambers, RF systems etc., including cabling and component alignment for each machine. System tests without beam, system debugging and preparation for commissioning (with beam) are expected to be performed within a period of 6 months.

This plan results in start of commissioning with beam for the Super-FRS in January 2012, allowing for first experiments in early 2012. However, achieving the full beam specification and intensities at the Super-FRS is expected to take up to 4 months in total. All rings need a comparable sequence for installation, testing, commissioning of typically 18 months. In this scenario the HESR is the machine that starts operation last early in 2015 (see Figure 7.4).

7.7 Critical Path

Despite intense preparations in the past, project development is determined by the progress in civil construction. In early 2006 the City of Darmstadt authorities formally agreed to the construction of FAIR buildings by approving a new development plan (Bebauungsplan). It allows for up to 117000 sq. m of area of new buildings. This is about a factor 2 more than required for FAIR. Starting bare brickwork is expected to begin in late 2008 as all buildings are located in a forested area.

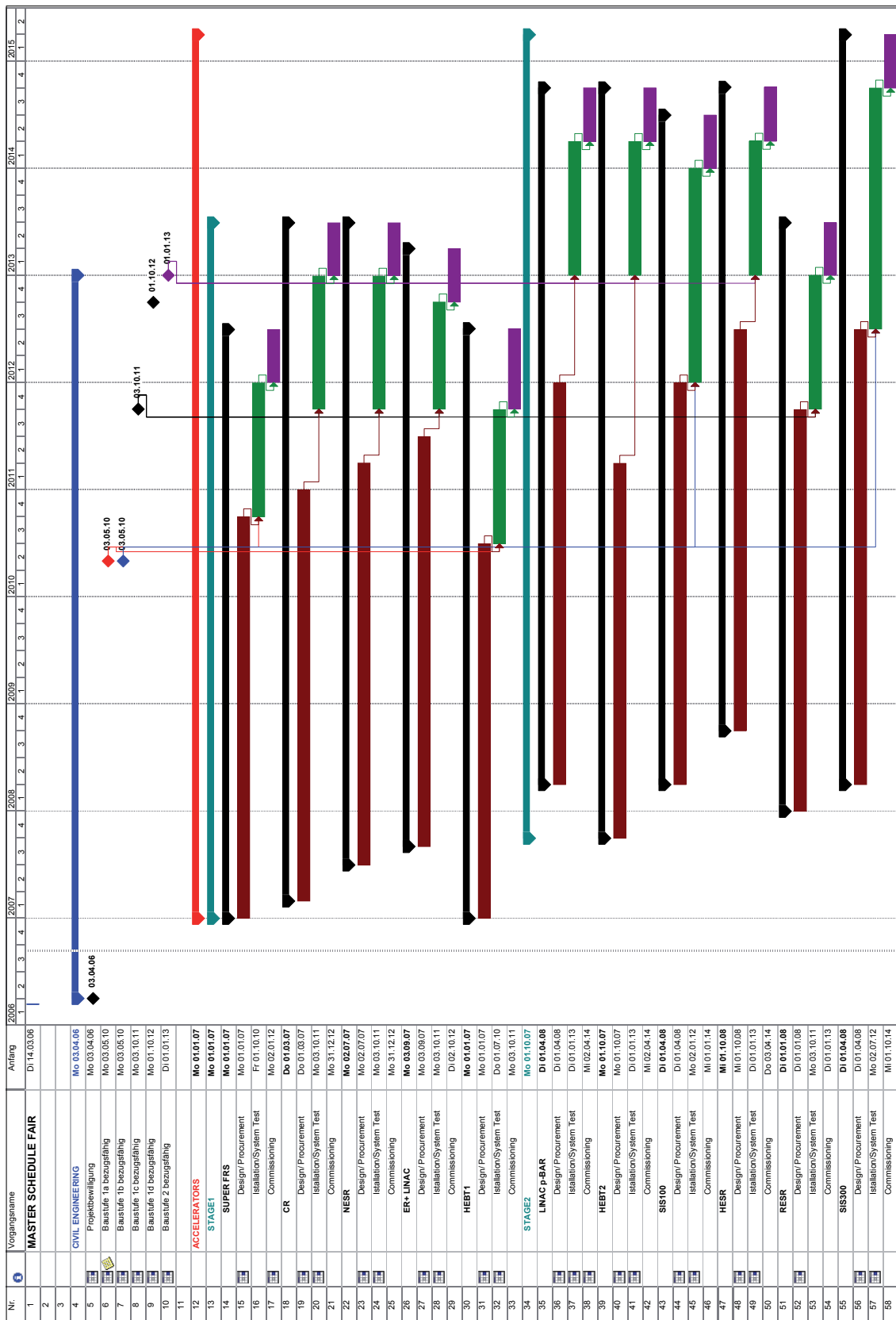

Figure 7.3: Schedule of civil construction milestones defining the start of installation and construction of accelerator subprojects

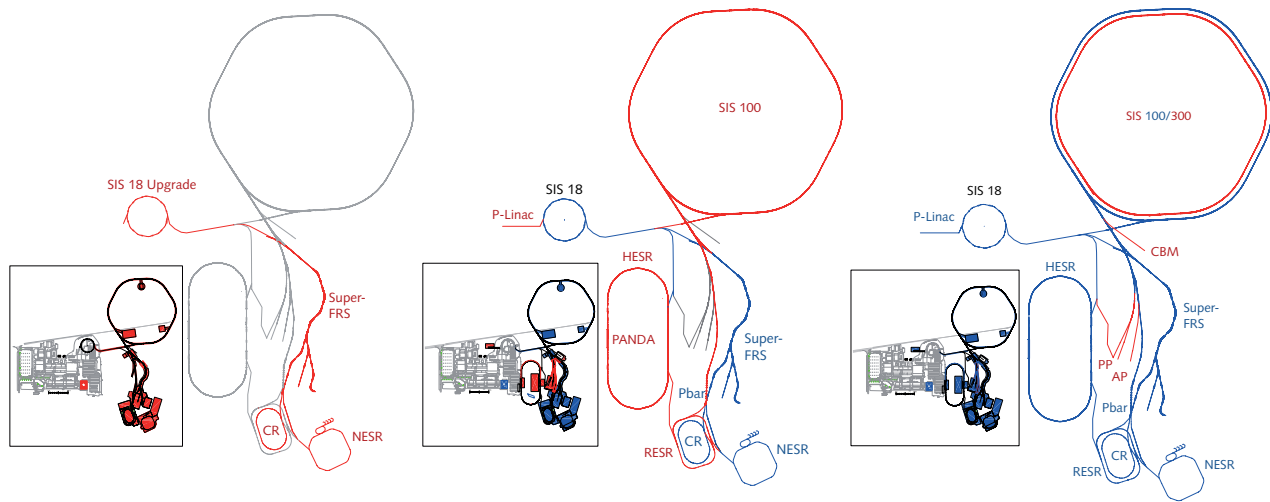

Figure 7.4: Schematic of the three stages of the construction of FAIR (from left to right). The ongoing construction of each stage is shown in red. The finished construction is shown in blue. The left corner inserts show the civil construction, the larger outline the progress of accelerators and experiments.

Furthermore plans are to use part of the existing ESR high energy experimental hall for installation of one of the two large He-refrigerators and - as mentioned before - re-use the main magnets of the existing ESR ring for the new RESR machine. To stay in the time-plan this requires shutdown of the ESR and preparing part of the experimental hall by the beginning of 2010.

7.8 Manpower - Resource Loaded Schedule

For the time being a scenario for the FAIR installation phase was worked out that covers the major workload for testing, installation and commissioning. This scenario is described as follows:

- Installation activities are restricted to the preassembly and assembly of the accelerator sections; installations apart from that have to be covered by the supplier of the civil construction systems and, at the experimental facilities, by the experiment collaborations.
- All technical systems from the accelerator subsystems are complete and are delivered after having passed successfully factory acceptance tests.
- All preassembly work necessary will be performed within existing halls at GSI (e.g. the high energy experimental hall); no additional assembly or test building is required.
- Assembly work for all systems and all sections is performed by an experienced assembly crew.
- All existing tooling at GSI can be used for the installation, additional tooling has to be specified,

constructed and manufactured within the work package item delivered.

- The assembly crew covers predominantly mechanical installation activities for the accelerator components.
- Installation labor e.g. for water cooling and cryogenic systems are covered by external firms on behalf of system suppliers.

With these boundaries the required personnel for the installation activities is estimated to be about 2000 man-years.

Distributing the resources according to the workload of the subprojects results in the resource loaded schedule as depicted in Figure 7.5. Especially during the installation phase of machines in 2011 to 2012 the peak load is in excess of 400 FTEs.

7.9 Budgetary Aspects

7.9.1 Spending Profile

The sequence of accelerator and civil construction is the basis for the required budget and spending profile. Dividing the project into subprojects related to experiments, civil construction and accelerators, each task was analyzed independently, adopting a realistic spending profile from similar sized projects and adding them up to a total project spending profile. The result is shown in Figure 7.6. The profile gives the required money-flow of experiments, civil engineering and technical components and cost for the personnel. During

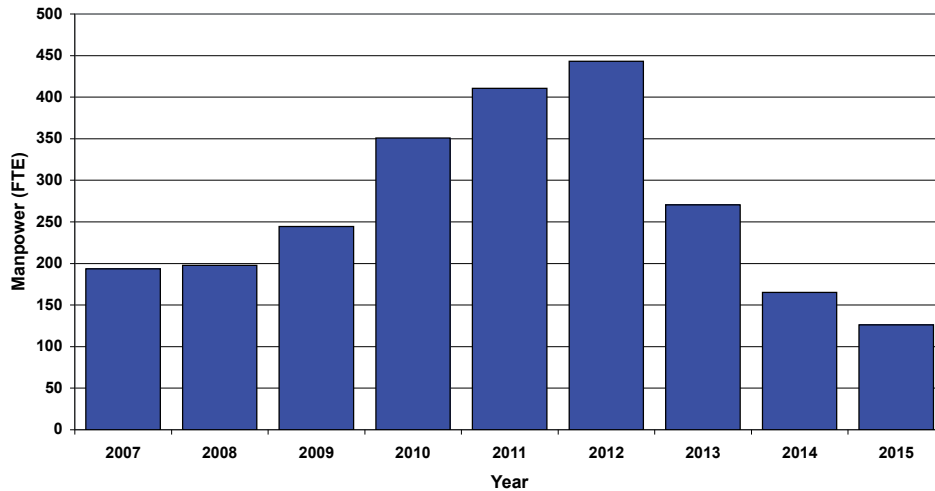

Figure 7.5: Resource loaded schedule.

the first three years the profile rises steeply, to a level of 170 to 180 M€/y in the fourth to eighth project year.

7.9.2 Risk budget

All items for the FAIR accelerators that were entered into Cost Book Rev. 3.0 have been assigned to a cost risk class, i.e. the expected range the actual price may deviate from the stated price. Depending on the quality of input of information (industrial quotation, scaling from previous procurement etc.) this range is $\pm 20\%$ in the worst case of price estimates and $\pm 5\%$ in the case of catalogue prices (Table 7.3).

A detailed risk analysis was performed. A meanwhile performed new risk analysis of the magnets assuming a risk class of -10% and $+20\%$ reduced the total risk to 15% . From the result of these analyses (Figure 7.7), a

risk budget of 15% will cover a probability of 95% to stay within the budget. In addition, assuming an average delay risk of six months as experienced by other large projects (HERA, LHC), the associated cost risk (in the form of increased personnel cost due to longer duration of the construction phase) is estimated at about 2% of the total project cost, which gives rise to a total of 17% .

7.10 Commissioning

7.10.1 Start of commissioning

Commissionings of the various accelerators have to take place when the respective installations have been finished, e.g. system tests ‚without beam‘ have been successfully performed for all components and sub-systems demonstrating their functionality including ‚readiness‘ of the accelerator control-system and in

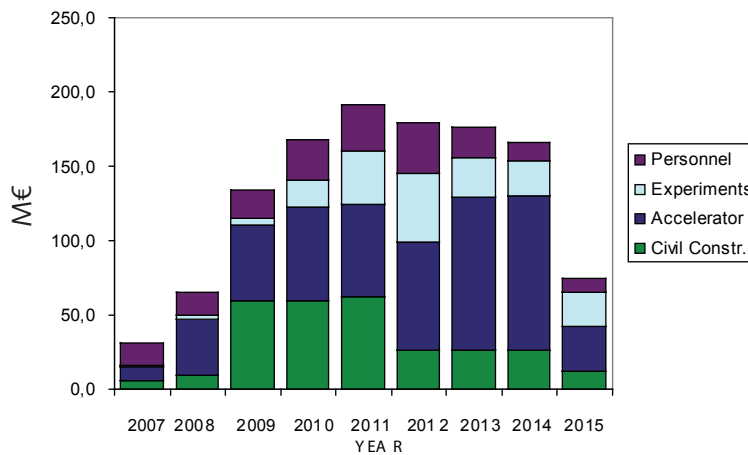

Figure 7.6: Spending profile for the FAIR project investment costs.

Table 7.3: Definition of cost risk classes and associated uncertainty.

Key	Code No.	Uncertainty
Vendor quotation	VQ	± 10%
Catalogue price	CP	± 5%
Estimated but undocumented price	EU	± 20%
Actual costs 19xx escalated to 2005	Axx	± 10%
Estimates from existing systems	EES	± 20%
Created cost reference	CCR	± 10%

particular the associated software. The costs for these activities are covered in the construction budget.

Commissioning ,with beam' is following the previous step when first beam parameter studies within the accelerator sections are started including defining and verifying set values for special functions, e.g. injection, extraction, acceleration, cooling etc. Part of commissioning is ,optimization with beam'. In this optimization phase settings for optimal beam performance over the whole intensity and energy range have to be established.

During the first commissioning phase physicists and also to a large extent engineers have to be involved; in the second and third step mainly accelerator physicists will be involved. During this phase the interfaces to the experimental subsystems also have to be tested and commissioned.

7.10.2 End of Commissioning

The start and end of commissioning and the beginning of operation has been recommended by the Committee on Scientific and Technical Issues (STI). Fulfilling qualitative technical criteria like beam qualities in the accelerators was also recommended by the Committee on Administrative and Financial Issues - Full Cost Issues (AFI-FCI) to be used as indicators. For each of the accelerator units, the transition from construction to commissioning and from commissioning to operation was specified separately. Thus commissioning of individual FAIR accelerators will end when beam parameters, appropriate to perform relevant experiments, are surpassed. These parameters, confirmed by STI are defining end of commissioning and start of operation, are listed in Table 7.4

7.10.3 Commissioning Costs

Commissioning costs have been evaluated and confirmed by STI on the basis of the individual accelerators.

Following the overall master schedule the availability of buildings determines the beginning of installations and thus start of commissioning. Fig. 7.8 depicts time for construction, commissioning and start of operation of the FAIR accelerators. A period of typically 3 to 4 month is assumed to reach the beam parameters defining start of operation.

For the evaluation of commissioning costs of individual accelerators the required manpower, consumables and their share in the costs of energy and infrastructure was used. The increased risk for malfunction of components in the presence of beam was taken into account. Starting with commissioning costs of the Super-FRS by the end of 2011 commissioning is spread until beginning of 2015. The required costs are depicted in Fig. 7.9. The total sum of commissioning costs is 26.5 M€.

7.11 Operation

The FAIR operating cost was estimated in great detail for accelerator staff, direct costs for accelerators and experiment installations, and shares in the costs, such as maintenance of buildings, IT, workshops, safety and user support. The costs operating the FAIR facility are 118 M€ given in 2005 prices. For the operation of accelerators, scientific-technical infrastructure and management, costs for manpower, consumables and investments for

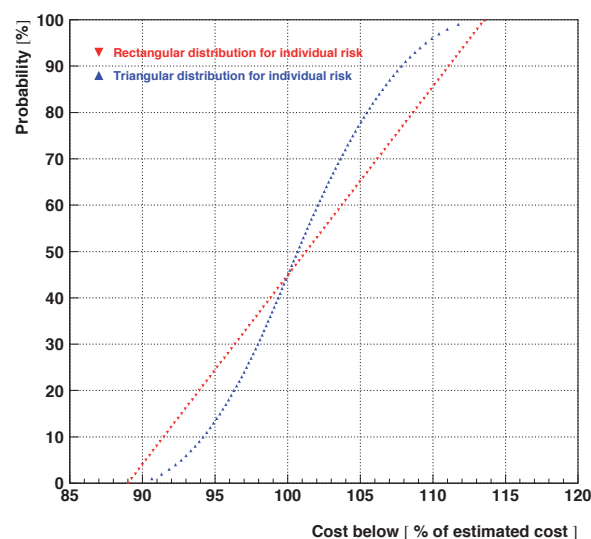

Figure 7.7: Result of the risk analysis – a risk budget of 15% covers a probability of 95% to stay within the project cost.

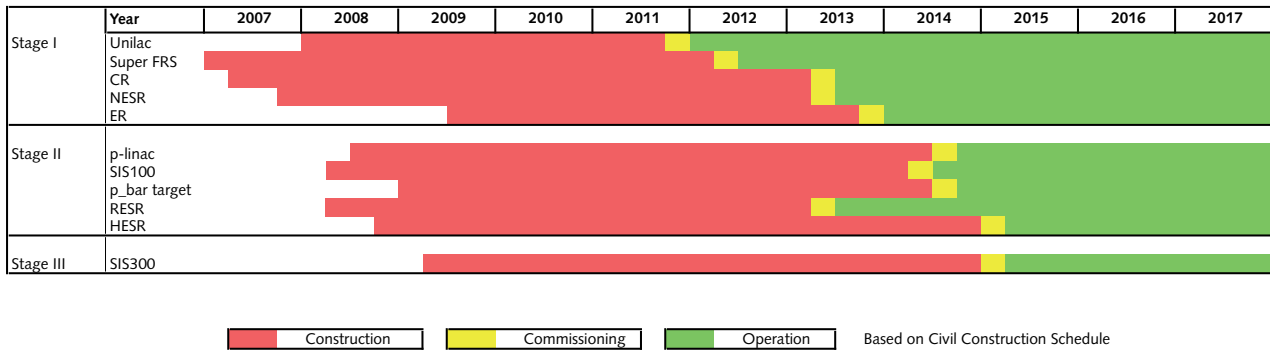

Figure 7.8: Schedule for construction, commissioning and operation for the individual FAIR accelerators

maintenance of accelerators, infrastructure and support, maintenance have been aggregated (see Table 7.5).

Energy costs have been evaluated on a typical operation scheme resulting in an average electrical power consumption of 30 MW for operating the FAIR installations and the injector.

For the accelerator, 320 FTE per year are assumed for operation, maintenance and refurbishment (based on a 24h/day 7 day/week operation for 5400 h of scheduled operation and additional time for technical start-up) when the facility is in full operation after the completion of stage 3. The cost per person year has been determined using the same methodology as for the construction phase. For replacements and maintenance consumables and investments of 3% of the accelerator investment costs have been accounted for. The direct accelerator operation costs amount to 46 M€/y.

A user support for the experimental program of 5 M€/y is included in the annual budget.

The scientific technical infrastructure comprises operation and maintenance of the media, cooling and air conditioning installations, IT support, workshops and construction offices; in total 270 FTE are required. Based on experience of running the GSI installations, costs for consumables and investments were scaled according to the size of FAIR installations, resulting in costs of 33 M€/y.

Management and other basic infrastructure to run the facility was costed to 10 M€/y.

Regarding partial operation after completion of stage 1 and 2 respectively, the estimated operation costs amount to 38,3 M€ in 2012, increasing to 58,1 M€ in 2013 and 97.1 M€ in 2014. The cost in 2015 will be 116.1 M€, close

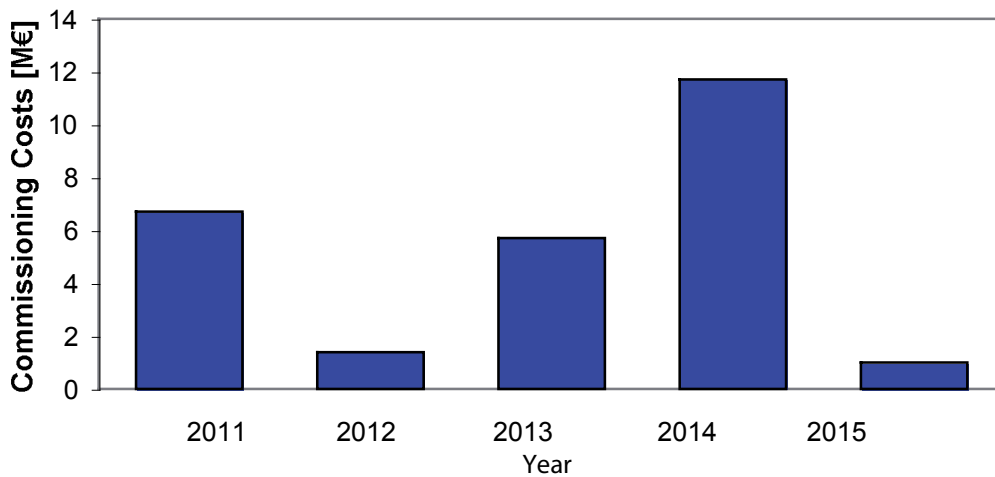

Figure 7.9: Commissioning costs of FAIR accelerators in the period 2011 to 2015.

Table 7.4: Beam parameters specifying end of commissioning for the FAIR accelerators.

No.	Accelerator unit	Stage of construction	Current, or number of particles		Repetition Rate		Bunch length		dp/p		Slow extraction	
			start of operation	final	start of operation	final	start of operation	final	start of operation	final	start of operation	final
1	UNILAC	1	2 mA U ⁷³⁺	3.5 mA U ⁷³⁺								
		2	5 mA U ²⁸⁺	15 mA U ²⁸⁺								
2	SIS18	1	1x10 ¹⁰ U ⁷³⁺ per cycle	3x10 ¹⁰ U ⁷³⁺ per cycle	1 Hz	4 Hz	50 ns	25 ns				
		2	2x10 ¹⁰ U ²⁸⁺ per cycle	1.5x10 ¹¹ U ²⁸⁺ per cycle	1 Hz	4 Hz						
3	CR	1	1x10 ⁵ ¹³² Sn ⁵⁰⁺ in the ring	Any ion up to space-charge limit					1x10 ⁻³	5x10 ⁻⁴		
4	NESR	1	5x10 ⁴ ¹³² Sn ⁵⁰⁺ in the ring	Any ion up to space-charge limit						5x10 ⁻⁴	1x10 ⁻⁴	
5	RESR	2	5x10 ⁴ ¹³² Sn ⁵⁰⁺ in the ring	Any ion up to space-charge limit						1x10 ⁻³	5x10 ⁻⁴	
6	SIS100	2	1.5x10 ¹⁰ U ²⁸⁺ per cycle	5x10 ¹¹ U ²⁸⁺ per cycle	0.5 Hz	nearly 1 Hz	150 ns	60 ns				
7	Proton Linac	2	3 mA protons	15 mA protons								
8	FLAIR	2	10 ⁸ anti-protons per NESR cycle	Up to space-charge limit in CR, RESR, NESR								
9	HESR	2	5x10 ¹⁰ anti-protons in ring	1x10 ¹¹ anti-protons in ring						5x10 ⁻⁴	1x10 ⁻⁴	
10	SIS300	3	2x10 ¹⁰ U ²⁸⁺ per cycle	4x10 ¹⁰ U ²⁸⁺ per cycle								10 ¹⁰ U ²⁸⁺ /s 3x10 ¹¹ U ²⁸⁺ /s

Table 7.5: Distribution of operation cost.

Item	Costs (M€)
Electrical power and water for FAIR relevant installations	24
Accelerators and rings	46
User Support	5
Scientific and technical infrastructure incl. buildings and civil construction	33
Basic infrastructure and management	10
Sum	118

to the full annual costs of 118 M€/y when all machines are in operation.

In the operating budget, no provisions are included for a scientific experimental program, comprising guest services, expenditures for travel, housing and meals for user groups, nor administrative and logistical measures for a visiting scientist program or a PhD student program.

8. Conclusion and Outlook

The present Baseline Technical Report (BTR) provides the technical description, cost, schedule, and assessment(s) of risk for the international FAIR project. The purpose of the BTR is to provide a reliable basis for the construction, commissioning and operation of the proposed facility and for its science use.

The BTR was conceived and developed in close collaboration between the international science community and the GSI Laboratory at Darmstadt, Germany. It represents the collective work of the FAIR community performed over the last 5 years since the publication of the original FAIR Conceptual Design Report (CDR). About 2500 authors from 45 countries, listed individually in this Report in the various technical proposals for experiments as well as in the technical reports for the accelerator work packages and technical infrastructures, underline the broad interest on the part of the international research community in the unique science opportunities expected from FAIR.

The BTR was prepared under the guidance of the International Steering Committee (FAIR-ISC), with representatives from the 13 partner countries, and a number of expert groups. The ISC members were delegated by their respective science ministries (or designated agency), under the umbrella of a Memorandum of Understanding (FAIR-MoU), signed by each of the partner countries. The MoU contains a declaration of collaboration for the development of the facility plans during the so-called preparatory phase, and an expression of interest to participate in the realization and use of the facility thereafter.

In the MoU, the BTR is listed as a key document to be prepared during the preparatory phase. A second important document for facility definition and implementation is the Cost Book. It provides the detailed listing of all technical components and of the technical manpower needed to complete the respective tasks. The Cost Book was generated together with this BTR.

The ISC was aided by two expert groups, the Working Group on Scientific and Technical Issues (FAIR-STI) and the Working Group on Addministrative and Financial Issues (FAIR-AFI). These groups in turn created specific advisory committees, comprising altogether nearly 100 world experts for the respective science and accelerator aspects. Together with STI and AFI, these committees were the key to a thorough assessment of the quality of the proposed research programs, the appropriateness and innovation of the proposed technical measures, the

soundness of their design, and the realistic estimates of cost and schedule.

The key features of the technical concept of FAIR can be summarized as follows: (i) highest-intensity, high-energy primary ion beams ranging from the lightest to the heaviest elements, from protons to uranium; (ii) optimized high-intensity secondary beams derived in-flight from the primary beams and ranging from energetic anti-protons to beams of short-lived nuclei near the drip lines; (iii) unique beam compression modes to provide the highest short-pulse beam powers; (iv) broad use of cooler-storage accelerator rings to collect and produce high-precision secondary beams with unparalleled phase space properties and unique in-ring experiment capabilities; (v) a high degree of parallel and independent operation of several ion beams and of antiprotons, which provides for a cost-effective but also synergetic operation of the facility. The facility provides for an order of magnitude increase in beam energy over the present heavy-ion accelerators at the GSI Laboratory, but the most important and unique characteristics are seen in the major steps forward on the intensity and precision frontiers.

The technical characteristics of the facility provide for exceptional, and in many respects worldwide unique performance parameters that will allow forefront research programs in a number of areas of science. They address in particular: (i) the investigation of the properties and the role of the strong (nuclear) force in shaping the basic building blocs of the visible world around us and of its role in the evolution of the universe; (ii) tests of symmetries and predictions of the standard models and their possible limitations, such as in quantum-electro-dynamics (QED) in the sector of the electro-weak force, and in quantum-chromo-dynamics (QCD) in the sector of the strong interaction; (iii) the properties of matter in extreme states and under unusual conditions, both at the subatomic, microscopic level as well as at the macroscopic levels of matter, antimatter, and bulk materials; and (iv) various applications of high-intensity, high-quality ion and antiproton beams in research areas underlying, or directly addressing, issues of applied sciences and technology.

The different research fields address, first of all, specific key questions in their respective areas of science. But they also intersect in common areas such as, for example, the issue of complexity. Complexity runs as a thread through many of the research programs, from non-perturbative QCD and the nuclear many-body system to biological

molecules and systems. Synergies that come from a broadly based research program may be expected for such overarching issues.

A central task of the BTR is to establish cost and schedule for the full project. Costs were evaluated on a component basis and then aggregated for the work packages. The methods for establishing component prices ranged from catalogue values and vendor quotations to estimates from recent procurements of identical and/or similar equipment, extrapolations from past constructions and developments (correcting for inflation etc.) to estimates based on new designs. The costs were scrutinized by the technical advisory committees with the goal to minimize cost while preserving technical performance: the TAC for the accelerators and technical infrastructure, the PACs for the experimental facilities. In specific areas of important and frequently used components (magnets, both normal and superconducting; beam diagnostics; vacuum; RF equipment and power supplies; cryogenics etc) special expert groups (mini-TACs) were assembled under the umbrella of the TAC to evaluate technical appropriateness and cost optimization. The component costs were then accumulated in the so-called Baseline Cost Book, a document listing costs for more than 5000 items.

The total project cost, for the facility configuration contained in the original Conceptual Design Report (CDR), compares within 10% with the original estimate, when corrected for inflation. (Inflation has to take into account the major price increases over recent years for raw

materials that are important for a facility construction such as FAIR, e. g. for iron ores and scrap metal, for copper etc.). In addition there is a 10% cost increase because of added capabilities that were proposed by the TAC and PAC review committees to increase facility performance and strengthen the science case. The Cost Book is part of this BTR but with restricted and controlled distribution at this point in time.

The schedule was worked out with two primary boundary conditions. (i) a staged approach with 3 phases that are oriented towards defined research capabilities and science goals: rare-isotope beam research after construction phase I, antiproton physics after stage II, compressed matter physics and full parallel operation after stage III; (ii) sequence and functionality in civil construction to minimize cost and optimize performance. The respective full schedule is given in the Cost Book.

Finally, while not part of this BTR, it is worth noting that the organizational scheme for the construction of FAIR involves two companies (GmbH) governed by German limited liability law, with the GSI GmbH as the site and host laboratory and the FAIR GmbH as the owner of the FAIR facility. The relevant documents (Convention, Articles of Association, By-Laws, Final Act etc.) are currently being prepared by AFI and the ISC.

We conclude that the present Report provides the baseline of all technical, cost and schedule information necessary to proceed with the construction of FAIR.

9. Appendix

Table 9.1: Signatories of the Memorandum of Understanding (MoU) of the FAIR project.

Country	Name	Institute	Date
Germany	Dr. H. Schunck, Director General	Federal Ministry of Education and Research	September 13 th , 2004
United Kingdom	Prof. Dr. J. V. Wood, Chief Executive	Council for the Central Laboratory of the Research Councils	September 13 th , 2004
Sweden	Dr. P. Omling, Director General	Swedish Research Council	September 21 st , 2004
Finland	Prof. Dr. Dan Olof Riska, Director	Helsinki Institute of Physics	September 22 nd , 2004
Spain	Dr. S. Ordóñez Delgado, State Secretary for Universities and Research	Ministry of Science and Education	October 06 th , 2004
Greece	Prof. Dr. C. Fotakis, Director	Institute of Electronic Structure and Laser FORTH-IESL	November 11 th , 2004
Russia	Dr. Sergey Mazurenko, Head of Science and Innovation Federal Agency	Science and Innovation Federal Agency	November 11 th , 2004
Italy	Dr. L. Criscuoli, Director General	Ministry of Education, University and Research	December 06 th , 2004
France	Prof. Dr. E. Giacobino, Director	Ministry of Research	December 08 th , 2004
Poland	Prof. Dr. R. Kulesa, Jagiellonian University, Kraków	Ministry of Science and Information Technology	January 18 th , 2005
India	Mr. Y. P. Kumar, Head of International Affairs	Department of Science and Technology	November 17 th , 2005
People's Republic of China	Meng Shuguang, Ma Yanhe, Deputy Directors General	Ministry of Science and Technology	November 24 th , 2005
Romania	Dr. Ionel Andrei	National Authority for Scientific Research	April 11 th , 2006

International Steering Committee (ISC)

Schunck, Hermann (Chair)	Ministry of Research and Education	Germany
Alejaldre, Carlos	Ministerio de Educación y Ciencia	Spain
Arajärvi, Mirja	Ministry of Education	Finland
Börjesson, Lars	Chalmers University of Technology and Göteborg University	Sweden
Charalambidis, Dimitris	Institute of Electronic Structure and Laser Foundation for Research and Technology	Greece
Fortuna, Graziano	Istituto Nazionale di Fisica Nucleare di Frascati	Italy
Gounand, Francois	Directeur Commissariat de l'Énergie Atomique	France
Ma Yanhe	Ministry of Science and Technology	China
Meng Shuguang	Ministry of Science and Technology	China
Kozlov, Yuri	Institute of Theoretical and Experimental Physics Moscow	Russia
Kulesa, Reinhard	University of Jagiellonski	Poland
Kumar, Y. P.	Ministry of Science and Technology	India
Sarkar, Dipankar	Embassy of India in Berlin	India
Vierkorn-Rudolph, Beatrix	Ministry of Research and Education	Germany
Wood, John	Council for the Central Laboratory of the Research Councils	United Kingdom
Zamfir, Nicolae Victor	Horia Hulubei National Institute of Physics and Nuclear Engineering	Romania

Working Group on Scientific and Technological Issues (STI)

Wenninger, Horst (Chair, Cern)	ex-CERN	
Gales, Sydney (until March 2005)	Grand Accelérateur National d'Ions Lourds (GANIL)	France
Åystö, Juha	University of Jyväskylä	Finland
Benlliure, José	University de Santiago de Compostela	Spain
Dalpiaz, Pietro	University of Ferrara	Italy
Danared, Hakan	Manne Siegbahn Laboratory (MSL)	Sweden
Fabbricatore, Pasquale	Istituto Nazionale di Fisica Nucleare di Genova (INFN)	Italy
Henning, Walter	Gesellschaft für Schwerionenforschung mbH (GSI)	Germany
Korten, Wolfram	Commission de l'Énergie Atomique (CEA)	France
Mueller, Alex C.	Institut de Physique Nucléaire d'Orsay (IPNO)	France
Riska, Dan-Olof	Helsinki Institute of Physics (HIP)	Finland
Rosner, Guenther	University of Glasgow	United Kingdom
Rubio, Berta	Instituto di Física Corpuscular (IFIC)	Spain
Sharkov, Boris	Institute for Theoretical and Experimental Physics (ITEP)	Russia
Simpson, John	Council for the Central Laboratory of the Research Councils (CCLRCC)	United Kingdom
Stroeher, Hans	Forschungszentrum Juelich (FZJ)	Germany
Wiedner, Ulrich	University of Uppsala	Sweden
Zhan Wenlong	Institute of Modern Physics (IMP) Chinese Academy of Sciences (CAS)	China

Observers

Gutbrod, Hans	Gesellschaft für Schwerionenforschung mbH (GSI)	Germany
Schroth, Peter	Ministry of Research and Education (BMBF)	Germany
Widmann, Eberhard	Stefan Meyer Institut für Subatomare Physik	Austria
Zamfir, Nicolae Victor	Horia Hulubei National Institute of Physics and Nuclear Engineering	Romania

Program Advisory Committee for the QCD Experiments (QCD-PAC)

Chiavassa, Emilio (Chair)	Istituto Nazionale di Fisica Nucleare di Torino (INFN)	Italy
Brodsky, Stanly J.	Stanford Linear Accelerator Center (SLAC)	USA
Dalpias, Pietro	Istituto Nazionale di Fisica Nucleare di Ferrara (INFN)	Italy
Geesaman, Donald	Argonne National Laboratory (ANL)	USA
Gustafsson, Hans Åke	University of Lund	Sweden
Kox, Serge	Inst. National de Physique Nucléaire et de Physique des Particules (IN2P3)	France
Landua, Rolf	CERN	
Magnon, Alain	CERN	
Maier, Rudolf	Forschungszentrum Jülich (FZJ)	Germany
Mueller, Bernd	Duke University	USA
Nelson, John	University of Birmingham	United Kingdom
Oset, Eulogio	Instituto de Física Corpuscular (IFK)	Spain
Riska, Dan-Olof	University of Helsinki	Finland
Stroeher, Hans	Forschungszentrum Jülich (FZJ)	Germany
Ritter, Hans Georg	Lawrence Berkeley Laboratory (LBL)	USA
Tserruya, Itzhak	Weizmann Institute of Science	Israel

Program Advisory Committee on NUSTAR Experiments

Casten, Rick (Chair)	University of Yale	USA
Azaiez, Faical	Institut de Physique Nucléaire d'Orsay (IPNO)	France
Butler, Peter	CERN	
Grawe, Hubert	Gesellschaft für Schwerionenforschung mbH (GSI)	Germany
Janssens, Robert	Argonne National Laboratory (ANL)	USA
Kubono, Shigeru	Centre for Nuclear Study (CNS), Rikagaku Kenkyusho (RIKEN)	Japan
Kurz, Kilian	Forschungszentrum Jülich (FZJ)	Germany
Meyer, Hans-Otto	University of Indiana	USA
Poves, Alfredo	University of Madrid	Spain
Rubio, Berta	Instituto die Fisica Corpuscular (IFIC)	Spain
Sherril, Bradley	Michigan State University	USA
Shotter, Alan	Canada's National Laboratory for Particle and Nuclear Physics (TRIUMF)	Canada
Villari, Antonio	Grand Accelérateur National d'Ions Lourds (GANIL)	France
Weick, Helmut	Gesellschaft für Schwerionenforschung mbH (GSI)	Germany
Wiescher, Michael	University of Notre Dame	USA

Program Advisory Committee for the APPA Experiments (APPA-PAC)

Schwalm, Dirk (Chair)	Max-Planck-Institut Heidelberg	Germany
Atzeni, Stefano	University of Rome "La Sapienza"	Italy
Basko, Michael	Institute for Theoretical and Experimental Physics Moscow (ITEP)	Russia
Drake, Gordon W. F.	University of Windsor	Canada
Indelicato, Paul	Université PM Curie Paris	France
Maynard, Gilles	Université Paris-Sud	France
Mehlhorn, Thomas A.	Sandia National Laboratories	USA
Norreys, Peter	Rutherford Appleton Laboratory (RAL)	United Kingdom
Sauerbrey, Roland	University of Jena	Germany
Sharkov, Boris	Institute for Theoretical and Experimental Physics Moscow (ITEP)	Russia
Spiller, Peter	Gesellschaft für Schwerionenforschung mbH (GSI)	Germany
Steck, Markus	Gesellschaft für Schwerionenforschung mbH (GSI)	Germany
Vernhet, Dominique	Université Paris 6 et 7	France
Yamazaki, Toshimitsu	Centre for Nuclear Study (CNS), Rikagaku Kenkyusho (RIKEN)	Japan

Technical Advisory Committee (TAC) on Accelerators, Storage Rings and Civil Engineering

Cho, Yanglai (Chair)	Argonne National Laboratory (ANL)	USA
Fabbricatore, Pasquale	Istituto Nazionale di Fisica Nucleare (INFN)	Italy
Garoby, Roland	CERN	
Ivanov, Sergey	Institute of High Energy Physics Protvino (IHEP)	Russia
Jacquemet, Marcel	Grand Accélérateur National d'Ions Lourds (GANIL)	France
Junquera, Tomas	Institut de Physique Nucléaire d'Orsay (IPNO)	France
Mueller, Alexander	Institut de Physique Nucléaire d'Orsay (IPNO)	France
Nolen, Jerry	Argonne National Laboratory (ANL)	USA
Ozaki, Satoshi	Brookhaven National Laboratory (BNL)	USA
Willeke, Ferdinand	Deutsches Elektronen-Synchrotron (DESY)	Germany

List of the expert groups (mini-TAC) and their members. These groups were formed by the TAC to review specific technical systems

Beam Diagnostics

Schmickler, Hermann	CERN	
Shea, Thomas J.	Oak Ridge National Laboratory (ORNL)	USA

Power Supplies

Bordry, Frederick	CERN	
Cutler, Roy	Oak Ridge National Laboratory (ORNL)	USA
Eckoldt, Hans-Joerg	Deutsches Elektronen-Synchrotron (DESY)	Germany
Fernqvist, Gunnar	CERN	
Fuja, Ray	Oak Ridge National Laboratory (ORNL)	USA
Jensen, Jens-Peter	Deutsches Elektronen-Synchrotron (DESY)	Germany

Proton Linac

Cutler, Roy	Oak Ridge National Laboratory (ORNL)	USA
Fuja, Ray	Oak Ridge National Laboratory (ORNL)	USA
Haseroth, Helmut	ex-CERN	

Cryogenics

Erdt, Wolfgang	ex-CERN	
Mulholland, George T.	Applied Cryogenics Technology (ACT)	USA
Petersen, Bernd	Deutsches Elektronen-Synchrotron (DESY)	Germany
Quack, Hans	Technical University Dresden	Germany
Trant, Rolf	CERN	
Wolff, Siegfried	Deutsches Elektronen-Synchrotron (DESY)	Germany

Warm Magnets

Marks, Neil	Daresbury National Laboratory	United Kingdom
Muto, Masayuki	KEK	Japan
Tuozzolo, Joseph	Brookhaven National Laboratory (BNL)	USA

Cold Magnets

Bottura, Luca	CERN	
Bruzzo, Pierluigi	Paul-Scherrer-Institut (PSI)	Switzerland
Fabbricatore, Pasquale	Istituto Nazionale di Fisica Nucleare di Genova (INFN)	Italy
Gourlay, Steve	Lawrence Berkeley Laboratory (LBL)	USA
Jacquement, Marcel	Grand Accelérateur National d'Ions Lourds (GANIL)	France
Kerby, Jim	Fermi National Accelerator Laboratory (FNAL)	USA
Scandale, Walter	CERN	
Taylor, Tom	ex-CERN	
Willen, Erich	Brookhaven National Laboratory (BNL)	USA
Wolf, Rob	CERN	

Cost Review Group on Accelerators, Infrastructure and Civil Engineering (CORE-A)

Plane, David (Chair)	ex-CERN	
Blasche, Klaus	Gesellschaft für Schwerionenforschung mbH (GSI)	Germany
Bacher, Reinhard	Deutsches Elektronen-Synchrotron (DESY)	Germany
Buhler-Broglin, Manfred	ex-CERN	
Erdt, Wolfgang	ex-CERN	
Fernqvist, Gunnar	CERN	
Gardner, Ian	Council for the Central Laboratory for the Research Councils (CCLRC)	United Kingdom
Haseroth, Helmut	ex-CERN	
Krämer, Dieter	Berliner Elektronenspeicherring-Gesellschaft für Synchrotronstrahlung mbH (BESSY)	Germany
Miralles, Lluís	Consortium for the Exploitation of the Synchrotron Light Laboratory	Spain
Stevenson, Graham	ex-CERN	
Strubin, Pierre	CERN	
Taylor, Tom	ex-CERN	
Weisse, Eberhard	ex-CERN	

Cost Review Group on Experiments (CORE-E)

Bartel, Wulfrin (Chair)	Deutsches Elektronen-Synchrotron (DESY)	Germany
Hilke, Hans-Juergen	ex-CERN	
Lazarus, Ian	Council for the Central Laboratory for the Research Councils (CCLRC)	United Kingdom
Lazeyras, Pierre	CERN	
Ritter, Hans Georg	Lawrence Berkeley National Laboratory (LBL)	USA
Simpson, John	Council for the Central Laboratory for the Research Councils (CCLRC)	United Kingdom
Vacchi, Andrea	Istituto Nazionale di Fisica Nucleare di Trieste (INFN)	Italy

Working Group on Administrative and Financial Issues (AFI)

Skeppstedt, Örjan (Chair)	Manne Siegbahn Laboratory	Sweden
Wagner, Hermann-Friedrich (until November 2005)	Ministry of Science and Education	Germany
Arajärvi, Mirja	Ministry of Education	Finland
Bogdanov, Peter	Ministry of Atomic Energy	Russia
Bravo, Yara	Istituto Nazionale die Fisica Nucleare di Frascati (INFN)	Italy
Dormy, Bernard	Ministère de la Recherche et aux Nouvelles Technologies	France
Eriksson, Leif	Swedish Research Council	Sweden
Godet, Nathalie	Centre National de la Recherche Scientifique (CNRS)	France
Guaraldo, Carlo	Istituto Nazionale di Fisica Nucleare di Frascati (INFN)	Italy
López, Andrés	Ministerio de Ciencia y Tecnología	Spain
Mattig, Ulrike	Ministry of Science and Arts of the State of Hessen	Germany
Patarkin, Oleg	Federal Atomic Energy Agency (ROSATOM)	Russia
Pellegrini, Roberto	Istituto Nazionale di Fisica Nucleare (INFN)	Italy
Popescu, Alexandru	Horia Hulubei National Research Institute of Physics and Nuclear Engineering	Romania
Pratt, Neil	Council for the Central Laboratory of the Research Councils (CCLRC)	United Kingdom
Vierkorn-Rudolph, Beatrix	Ministry of Research and Education	Germany
Xie Ming	Institute of Modern Physics (IMPCAS), Chinese Academy of Sciences	China
Observers		
Grapentin, Jan	Ministry of Research and Education	Germany
Gutbrod, Hans H.	Gesellschaft für Schwerionenforschung mbH (GSI)	Germany
Henning, Walter F.	Gesellschaft für Schwerionenforschung mbH (GSI)	Germany
Hieber, Sabine	Ministry of Research and Education	Germany
Kurz, Alexander	Gesellschaft für Schwerionenforschung mbH (GSI)	Germany

AFI group on Legal Frame Issues (AFI-LFI)

Jahn, Bernd-U. (Chair)	European Molecular Biology Laboratory (EMBL)	Germany
Arajärvi, Mirja	Ministry of Education	Finland
Delissen, Thomas	Deutsches Elektronen-Synchrotron (DESY)	Germany
Fangohr, Hanna	Hamburg Authority for Science and Research	Germany
Godet, Nathalie	Centre National de la Recherche Scientifique (CNRS)	France
Gutbrod, Hans	Gesellschaft für Schwerionenforschung mbH (GSI)	Germany
Hieber, Sabine	Ministry of Research and Education	Germany
Kurz, Alexander	Gesellschaft für Schwerionenforschung mbH (GSI)	Germany
Leclercq, Nathalie	European Molecular Biology Laboratory (EMBL)	Germany
Maske-Demand, Birgit	Hessen Ministry of Science and Arts	Germany
Miralles, Luís	Ministerio de Ciencia y Tecnología	Spain
Palumbo, Luigi	Istituto Nazionale di Fisica Nucleare di Frascati (INFN)	Italy
Scherf, Christian	Deutsches Elektronen-Synchrotron (DESY)	Germany
Witte, Karl	European Synchrotron Radiation Facility (ESRF)	France

AFI group on Full Cost Issues (AFI-FCI)

Brandt, Björn (Chair)	Swedish Foundation for Strategic Research	Sweden
Dormy, Bernard	Ministère de la Recherche et aux Nouvelles Technologies	France
Eriksson, Leif	Swedish Research Council	Sweden
Fangohr, Hanna	Hamburg Authority of Science and Research	Germany
Godet, Nathalie	Centre National de la Recherche Scientifique (CNRS)	France
Grapentin, Jan	Ministry of Research and Education	Germany
Hieber, Sabine	Ministry of Research and Education	Germany
Kurz, Alexander	Gesellschaft für Schwerionenforschung mbH (GSI)	Germany
Maske-Demand, Birgit	Hessen Ministry of Science and Arts	Germany
Miralles, Luís	Consortium for the Exploitation of the Synchrotron Light Laboratory	Spain
Palumbo, Luigi	Istituto Nazionale di Fisica Nucleare di Frascati (INFN)	Italy
Scherf, Christian	Deutsches Elektronen-Synchrotron (DESY)	Germany
Wells, Steve	Council for the Central Laboratory of the Research Councils (CCLRC)	United Kingdom
Witte, Karl	European Synchrotron Radiation Facility (ESRF)	France

List of Authors of the FAIR Baseline Technical Report

FAIR Coordination

Darmstadt, Gesellschaft für Schwerionenforschung (GSI)
 I. Augustin, T. Beier, K. Berghöfer, J. Eschke, H.H. Gütbrod, M. Hinkelmann,
 S. Hofmann, K.D. Gross, C. Pomplun

FAIR Accelerators

CHINA
 Beijing, Institute of Electrical Engineers (IEE)
 Q. Wang
 Hefei, Academy Sinica Institute of Plasma Physics (ASIPP)
 S. Wu
 Lanzhou, Institute of Modern Physics (IMP-CAS)
 Y. He, L. Ma, P. Yuan, X. Yang, J. Zhang

FRANCE

Belfort, Alstom

F. Beaudet, A. Bourquard, C. Kohler

GERMANY

Bergisch Gladbach, ACCEL

R. Burgmer, D. Krischel, P. Schmidt

Bonn, Rheinische Friedrich-Wilhelms-Universität

F. Hinterberger

Darmstadt, Gesellschaft für Schwerionenforschung (GSI)

B. Achenbach, N. Angert, T. Aumann, R. Balß, R. Bär, W. Barth, F. Becker, K.-H. Behr,
 C. Bellachioma, S. Berlinghof, K. Blasche, A. Bleile, U. Blell, O. Boine-Frankenheim,
 M. Bousonville, R. Boywitt, G. Breitenberger, A. Brünle, L. Dahl, K. Dermati, C. Dorn,
 G. Eichler, H. Eickhoff, H. Emling, G. Fehrenbacher, E. Fischer, E. Floch, P. Forck,
 G. Franchetti, B. Franczak, B. Franzke, A. Galatis, H. Geissel, T. Giacomini, M. Gleim,
 L. Groening, R. Hasse, L. Hechler, G. Heß, T. Hoffmann, I. Hofmann, R. Hollinger,
 M. Hörst, W. Hüller, P. Hülsmann, G. Hutter, H. Iwase, W. Jacoby, P. Kainberger,
 R. Kaiser, E. Kammer, C. Karagiannis, K. Kaspar, W. Kaufmann, J. Kaugerts,
 M. Kauschke, A. Kelic, H. Kiesewetter, B. Kindler, M. Kirk, G. Klappich, H. Klingbeil,
 F. Klos, H. G. König, H. Kollmus, M. Konradt, V. Kornilov, P. Kowina, E. Kozlova,
 A. Krämer, D. Krämer, U. Krause, M. Kumm, N. Kurz, U. Laier, K. Lang, H. Leibrock,
 Y. Litvinov, B. Lommel, F. Marzouki, M. Mehler, J. Mohr, G. Moritz, P. Moritz, C. Mühle,
 G. Münzenberg, E. Mustafin, M. Nagel, R. Neumann, C. Nociforo, C. Omet, A. Peters,
 I. Pschorn, N. Pyka, T. Radon, H. Ramakers, S. Ratschow, A. Redelbach, H. Reeg,
 H. Reich-Sprenger, S. Richter, M. Sayed, V. Schaa, C. Scheidenberger, W. Schiebel,
 A. Schlöft, G. Schnizer, R. Scholz, G. Schreiber, C. Schroeder, P. Schütt, H. Simon,
 P. Spädike, P. Spiller, J. Stadlmann, M. Steck, K. Summerer, N. A. Tahir,
 Chr. Traudmann, W. Vinzenz, G. Walter, B. Weckenmann, H. Weick, M. Weipert,
 H. Welker, S. Willert, M. Winkler, T. Wöber, Y. Xiang, S. Yarumyshev, X. Yu, O. Zurkan
Darmstadt, Technische Universität
 B. Dolliva, W. Ensinger, H. Fueß, H. Gerssem, M. Glesner, A. Gruzdeva, A. Guntero,
 T. Holstein, P. Meissner, O. Soffke, P. Zipf, A. Zoubir
Dresden, Technische Universität
 A. Kutschbach, H. Quack

Frankfurt, Johann Wolfgang Goethe-Universität
 L. Brendel, G. Clemente, B. Hofmann, Z. Li, H. Podlech, U. Ratzinger, A. Schempp,
 R. Tiede

Fulda, Fachhochschule

K. Fricke-Neudert, B. Zipfel

Giessen, Justus-Liebig-Universität

D. Boutin, W. Plass

Hamburg, Deutsches Elektronen-Synchrotron (DESY)

K. Knaak, S. Wolff

Ismaning, Communications & Power Industries (CPI)

H. Bohlen, W. Tschunke

Jena, Friedrich-Schiller-Universität (FSU)

R. Neubert, G. Staupendahl, W. Vodel

Jülich, Forschungszentrum Jülich (FZJ)

S. An, K. Bongardt, J. Dietrich, R. Eichhorn, O. Felden, A. Lehrach, B. Lorentz,

R. Maier, S. Martin, D. Prasuhn, A. Schmase, Y. Senichev, E. Senicheva, R. Stassen,

H. Stockhorst, R. Tölle, D. Welsch, E. Zaplatin

Karlsruhe, Forschungszentrum Karlsruhe (FZK)

W. Goldacker, A. Nylas, S. Schlachter, R. Stieglitz

Kassel, Universität Kassel

J. Becker, M. Häpe, W. Ricken

Langenbiersdorf, Gerlinde Schulteis & Partner GbR (UGS)

S. Martin, Chr. Wiedner

Mainz, Fachhochschule

A. Marbs

Mainz, Johannes-Gutenberg-Universität

K. Wendt

Marburg, Philipps-Universität

D. Severin

Wiesbaden

B. Langenbeck

Würzburg, Babcock Noell Nuclear (BNN)

W. Gärtner, M. Gehring, T. Grasmann, H. Scheller, W. Walter, A. Wessner

FINLAND

Jyväskylä, University of Jyväskylä

J. Äystö, A. Jokinen, I. Moore

FRANCE

Saclay, Commissariat à l'Energie Atomique (CEA/Saclay)

A. Dael, R. Gobin, A. Payn, J.-M. Rifflet

Vélizy, Thales Electron Device

A. Beunas, R. Marchesin

JAPAN

Hitachi-City, Hitachi Ltd., Power Systems

T. Hae, K. Saito

Saitama, RIKEN

T. Kubo, K. Kusaka, A. Yoshida

Tokyo, RIKEN

T. Kubo

Yokohama, Toshiba

Y. Kanai, T. Miyaoka

- JORDAN**
Irbid, Yarmouk University
 A. Al-Khateeb
- NETHERLANDS**
Enschede, University of Twente
 A. den Ouden
Groeningen, Kernfysisch Versneller Instituut (KVI)
 S. Brandenburg, P. Dendooven
- RUSSIA**
Dubna, Joint Institute for Nuclear Research (JINR)
 N. Agapov, P. Akishin, A. Alfeev, V. Batin, V. Bartenev, A. Butenko, A. Doniagin, V. Drobin, A. Eliseev, I. Eliseeva, Y. Filipov, E. Ivanov, V. Karpinsky, I. Karpunina, H. Khodzhibagyan, V. Koksharov, O. Kozlov, A. Kovalenko, G. Kuznetsov, V. Mikhaylov, P. NikitaeV, V. Safronov, V. Seleznev, A. Shabunov, Y. Shishov, A. Smirnov, A. Starikov, Y. Tjatyushkin, B. Vasilishin, V. Volkov, L. Zaitsev
Moscow, Fund Kurchatov Technopark
 V. Keilin
Moscow, Institute for Nuclear Research of the Russian Academy of Sciences (INR RAS)
 N. Sobolevsky, L. Latysheva
Moscow, Institute for Theoretical and Experimental Physics (ITEP)
 A. Bolshakov, A. Golubev, D. Kashinsky, D. Liakin, S. Minaev, V. Pershin, V. Skachkov, P. Zenkevich
Moscow, Institute High Energy Physics (IHEP)
 I. Bogdanov, S. Kozub, R. Kurmishov, P. Scherbakov, V. Sytnik, L. Tkachenko, S. Zintchenko, V. Zubko,
Moscow, Joint Stock Company VNIIEP
 V. Sytnikov, A. Taran, V. Vysotsky
Moscow, Moscow Radio Technical Institute
 A. Durkin
Novosibirsk, Budker Institute of Nuclear Physics (BINP)
 V. Arbuзов, E. Gorniker, I. Koop, S. Krutikhin, G. Kurkin, P. Logatchov, V. Osipov, V. M. Panasiuk, V. V. Parkhomchuk, V. Petrov, V. B. Reva, P. Y. Shatunov, Y. M. Shatunov, A. Skrinsky, M. A. Vedenev, P. Vobly
St. Petersburg, Polytechnical University
 A. Kalimov
St. Petersburg, Russian Academy of Science (RAS)
 M. Svedentsov, M. Yavor
St. Petersburg, D. V. Efremov Scientific Institute of Electrophysical Apparatus
 S. Egorov, I. Rodin
- SLOVAKIA**
Bratislava, Comenius University
 B. Sitar
- SLOVENIA**
Solkan, Instrumentation Technologies
 T. Karcnik, R. Uri
- SPAIN**
Madrid, Elytt Energy
 A. Echeanadia, J. Lucas
- SWEDEN**
Stockholm, Manne Sigbahn Laboratory (MSL)
 A. Paal
Uppsala, Uppsala University
 T. Bergmark, B. Gálnander, T. Johnson, T. Lofnes, G. Norman, D. Reistad
- SWITZERLAND**
Geneva, European Organization for Nuclear Research (CERN)
 B. Auchmann, J. Belleman, L. Bottura, F. Caspers, D. Cornuet, O. Dunkel, P. Fessia, D. Hagedorn, J. Jeffrey, D. Möhl, V. Parma, P. Pugnât, U. Raich, P. Rohmig, S. Russenschuck, A. Sziemko, N. Smirnov, L. Thorndahl, D. Tommasini, L. Walkiers
Villigen, Centre de Recherches en Physique des Plasmas (CRPP)
 P. Bruzzone
- UNITED KINGDOM**
Abingdon
 M. Wilson
Chesham, Sundance Multiprocessor Technology Ltd
 P. S. Robert, E. H. L. Wheatley
Chilton, Rutherford Laboratory
 T. Bradshaw, S. Canfer, J. Greenhalgh, S. Robertson
Edinburgh, 3L Ltd.
 P. S. Robertson, H. P. Veldman
- USA**
Argonne, Argonne National Lab.,
 A. Kolomiets, J. A. Nolen, G. Savard
Batavia, Fermi National Accelerator Laboratory (FNAL)
 R. Pasquelli
Berkeley, Lawrence Berkeley National Laboratory (LBL)
 S. Caspi, D. Dieterich, P. Ferracin, R. Scanlan
Boston
 E. Bobrov
East Lansing, Michigan State University (MSU)
 M. Berz, S. Manikonda, D. Morrissey, R. Romningen, B. M. Sherrill, A. F. Zeller
Livermore, Lawrence Livermore National Laboratory (LLNL)
 L. Ahle
Oakland,
 W. Hassenzahl
Ovilla, Applied Cryogenics Technology (ACT)
 H. Mulholland
San Carlos, Communications & Power Industries
 E. Wright
Upton, Brookhaven National Laboratory (BNL)
 M. Anerella, J. Escallier, G. Ganetis, A. Ghosh, A. Jain, P. Joshi, W. Louie, A. Marone, J. Muratore, J. Schmalzle, R. Soika, R. Thomas, P. Wanderer, E. Willen
- FAIR Civil Engineering**
- GERMANY**
Darmstadt, Gesellschaft für Schwerionenforschung (GSI)
 G. Aberin-Wolters, B. Becker-de Mos, G. Fehrenbacher, A. Fischer, B. Froitzheim, H. Kühlen, H. Ramakers, H. Welker

Darmstadt, Technische Universität Darmstadt (TUD)
 J. Gierle, S. Wachter
Heidelberg, BUNG Ingenieure AG
 H. Hillman, Th. Kennepohl

FAIR Safety and Radiological Protection

GERMANY

Darmstadt, Gesellschaft für Schwerionenforschung (GSI)

G. Fehrenbacher, J. G. Festag, F. Gutermuth, A. Knapp, G. Moustafina, A. Niermeyer,
 D. Plazura-Olszowski, T. Radon

RUSSIA

Dubna, Joint Institute for Nuclear Research (JINR)

G. Shabratova

CBM Collaboration

CHINA

Hefei, University of Science & Technology of China

H. Chen, Z. Zhang, C. Li, X. Wang, J. Wu, M. Shao, X. Dong, M. Xu
Wuhan, Hua-zhong Normal University
 X. Cai, T. Wu, Z. Yin, D. Zhou

CROATIA

Zagreb, Rudjer Bošković Institute

Z. Basrak, R. Caplar, M. Dželalija, I. Gašparić, M. Kiš

CYPRUS

Nikosia, University of Cyprus

J. Mousa, H. Tsertos

CZECH REPUBLIC

Prag, Czech Technical University (CTU)

V. Petracek, V. Pospisil, L. Skoda

Rež, Nuclear Physics Institute

D. Adamova, A. Kugler, P. Tlustý

GERMANY

Darmstadt, Gesellschaft für Schwerionenforschung (GSI)

J. Adamczewski, M. Al-Turany, A. Andronic, E. Badura, E. Berdermann, D. Bertini,
 P. Braun-Munzinger, M. Cloban (NIPNE, Bucharest), S. Das, H. Deppa, M. Deveau,
 J. Eschke, H. Essel, H. Flemming, V. Friese, T. Galatyuk, C. Garabatos, D. Gonzales,
 J. Heuser, C. Höhne, R. Holzmann, M. Kallisky, Young-Jin Kim, A. Kiseleva, K. Koch,
 P. Koczon, W. König, B. Kolb, D. Kresan, Y. Leifels, S. Linev, W.F.J. Müller, W. Niebur,
 A. Schütttauf, P. Senger, R. Simon, F. Uhlig, I. Vassiliev
Frankfurt, Johann Wolfgang Goethe-Universität

S. Amar-Youcef, H. Appelshäuser, I. Fröhlich, M. Hartig, C. Müntz, H. Ströbele, J. Stroth

Heidelberg, Ruprecht-Karls-Universität

M.L. Benabderrahmane, E. Cordier, N. Herrmann, A. Mangiarotti, M. Merschmeyer,
 K. Schweda

Heidelberg, Kirchhoff-Institut für Physik

D. Atanasov, U. Kbschull, I. Kisel, V. Lindenstruth, G. Torralba, G. Tröger

Kaiserslautern, Technische Universität Kaiserslautern

D. Muthers, R. Tielert, S. Tontisirin

Mannheim, Universität Mannheim

K.-H. Bremner, U. Brüning, P. Fischer, H. Fröning, J. Gläß, C. Kreidl, R. Männer,
 M. Nüsse, D. Slognat, C. Steinle, Gao Wenxue, D. Wohlfeld, A. Wurz

Münster, Westfälische Wilhelms Universität Münster

M. Hoppe, C. Klein-Bösing, K. Reygers, A. Wilk, J. Wessels

Rosendorf, Forschungszentrum Rosendorf (FZR)

F. Dohrmann, E. Grosse, K. Heidel, B. Kämpfer, R. Kotte, L. Naumann

FRANCE

Strasbourg, Institut de Recherches Subatomiques (IRes), IN2P3-CNRS and Université

Louis Pasteur Strasbourg

A. Besson, G. Claus, A. Dorokhov, W. Dulinski, S. Heini, A. Himmi, K. Jaaskelainen,
 F. Rami, I. Valin, M. Winter

HUNGARY

Budapest, Eötvös University

F. Deak, R. Izsak, A. Kiss

Budapest, KFKI Research Institute for Particle and Nuclear Physics (KFKI-RMKI)

L. Boldizsar E. Denes, Z. Fodor, E. Futo, J. Kecskemeti, T. Kiss, A. Laszlo, Cs. Soos,
 T. Tolyhi, G. Vesztergombi

INDIA

Kolkata, Variable Energy Cyclotron Centre (VECC)

Z. Ahmad, S. Chattopadhyay, M.R. DuttaMajumdar, P. Ghosh, B. Mohanty,
 G.S.N. Murthy, S.R. Narayan,
 T. Nayak, S. Pal, Y. Sainis, V. Singhal, Y. P. Vijoyi

KOREA

Pusan, Pusan National University (PNU)

K.U. Choi, J. Kim, I.K. Yoo

Seoul, Korea University

B. Hong, T.I. Kang, M.S. Ryu, K.S. Sim

NORWAY

Bergen, University of Bergen

D. Röhrich, K. Ullaland

POLAND

Katowice, University of Silesia

A. Bubak, A. Grzeszczuk, S. Kowalski, M. Krauze, E. Stephan, W. Zipper

Kraków, Jagiellonian University

J. Brzywczyk, R. Karabowicz, Z. Majka, P. Staszal

Warsaw, Warsaw University

M. Kirejczyk, T. Matulewicz, K. Piasecki, B. Sikora, K. Siwek-Wilczynska, K. Wisniewski

PORTUGAL

Coimbra, Laboratório de Instrumentação e Física Experimental de Partículas (LIP)

P. Fonte, R. Ferreira Marques

ROMANIA

Bucharest, National Institute for Physics and Nuclear Engineering (NIPNE)
C. Aftimiei, V. Catanescu, G. Caragheorghieopol, C. Magureanu, D. Moisa, M. Petris,
A. Petrovici, M. Petrovici, A. Pop, A. Raduta, V. Simion, G. Stoicea

RUSSIA

Dubna, Joint Institute for Nuclear Research, (JINR-LHE)
V. Chepurinov, S. Chernenko, O. Fateev, V. Golovatyuk, A. Ierusalimov, V. Ladygin,
A. Malakhov, E. Matyusheskiy, E. Plekhanov, V. Pozdniakov, O. Rogachevsky,
Yu. Zanevsky, V. Zrjuev

Dubna, Joint Institute for Nuclear Research (JINRLPP)
Ju. Gousakov, G. Kekelidze, V. Lucento, V. Mialkovski S. Mishin, D. Peshekhonov,
V. Peshekhonov, O. Sirekaloyskiy, K. Viriasov

Dubna, Joint Institute for Nuclear Research (JINR-LIT)
P. Akishin, E. Akishina, S. Baginyan, Victor Ivanov, Valery Ivanov, B. Kostenko,
S. Lebedev, E. Litvinenko, G. Ososkov, A. Raportirenko, A. Solovjev, P. Zrelov,
V. Uzhinskiy

Gatchina, Petersburg Nuclear Physics Institute (PNPI)
V. Baublis, N. Bondar, V. Golovtsov, V. Ivanov, A. Khanzadeev, A. Nadtochiy, Y. Riabov,
V. Samsonov, D. Seliverstov, O. Tarassenkova, E. Vznuzdaev, M. Zhalov

Moscow, Institute for Nuclear Research
M. Golubeva, F. Guber, A. Ivashkin, O. Karavichev, T. Karavicheva, E. Karpechev,
A. Kurepin, A. Maevskaya, I. Peshenichnov, V. Rasin, A. Reshetin, V. Tiflov,
N. Topilskaya, I. Veretenkin

Moscow, Alikhanov Institute for Theoretical and Experimental Physics (ITEP)
A. Akimov, A. Arefiev, S. Belogurov, Y. Grishuk, A. Goltutvin, S. Kiselev, I. Korolko,
T. Kvaracheliya,

V. Maiatski, S. Malyshev, A. Martemiyarov, K. Mikhailov, P. Polozov, M. Prokudin,
G. Sharok, A. Smirnitkiy, A. Stavinskiy, V. Stolin, K. Voloshin, B. Zagreev, Smolyankin
laboratory: Y. Grishkin, A. Lebedev, N. Rabin, V. Smolyankin, A. Zhilin

Moscow, Lomonosov Moscow State University (SINP-MSU)
N. Baranova, G. Bashindjagyan, D. Karmanov, M. Korolev, M. Merkin, A. Voronin

Moscow, Kurchatov Institute
A. Kazantsev, V. Manko, I. Yushmanov

Moscow, Moscow Engineering Physics Institute (MEPhI)
M. Alyushin, E. Aikin, Y. Bocharov, B. Bogdanovich, V. Emelianov, I. Ilyushenko,
A. Krasnuk, E. Omishchenko, V. Popov, A. Silaev, A. Simakov, Y. Volkov

Obninsk, Obninsk State Technical University for Nuclear Power Engineering
V. Galkin, A. Golovin, D. Ossetski, D. Ryzhikov, V. Saveliev, M. Zaboudko

Protvino, Institute for High Energy Physics (IHEP)
V. Ammosov, M. Bogolyubsky, V. Dyatchenko, Yu. Kharlov, V. Khmelnikov, V. Leontiev,
V. Obratsov, B. Polishchuk, A. Ryazantsev, V. Rykalin, S. Sadovskiy, A. Semak,
V. Shelikhov, A. Soldatov, V. Sougonyaev, Y. Sviridov, V. Victorov, V. Zaets

St. Petersburg, V.G. Khlopin Radium Institute (KRI)
M. Chubarov, S. Igolkin (CKBM), V. Karasev, S. Lashaev, Y. Murin, V. Plyushev,
E. Seleznev

St. Petersburg, St. Petersburg State Polytechnic University (SPbSTU)
A. Berdnikov, Y. Berdnikov, E. Kryshen, M. Ryzhinskiy

UKRAINE

Kyiv, National Taras Shevchenko University
O. Bezshyyko, I. Kadenko, V. Plujko, V. Shevshenko

PANDA Collaboration**AUSTRIA**

Vienna, Stefan Meyer Institut für Subatomare Physik
M. Cargnelli, H. Fuhrmann, P. Kienle, J. Marton, E. Widmann, J. Zmeskal

BELARUS

Minsk, Belarus State University
V.I. Dornenev, G.Y. Drobychev, A.A. Fedorov, A.E. Korneev, M.V. Korzhik, A.R. Lopatik,
O.V. Missevitch

Minsk, National Center of Particle and High Energy Physics (NCPHEP)
N. Shumeiko, A. Solin

CHINA

Beijing, Institute of High Energy Physics
J.J. Xie, B.S. Zou

Lanzhou, Institute of Modern Physics (IMP-CAS)
R. Chen, L. Duan, Z. Hu, W. Li, Z. Sun, G. Xiao, Z. Xiao, H. Xu, H. Xu

FRANCE

Orsay, Institut de Physique Nucléaire (IPNO)
M. Guidal, T. Hennino, M. Mac Cormick, S. Ong, B. Ramstein, J. Van deWiele,
J. Pouthas, P. Rosier,
T. Zergueras

GERMANY

Bochum, Ruhr-Universität
A. Golischewski, K. Götzten, T. Held, H. Koch, B. Kopf, B. Lewandowski, H. Nowak,
H. Schmücker, M. Steinke, P. Wiecezorek, A. Wilms, J. Zhong

Bonn, Helmholtz-Institut für Strahlen- und Kernphysik
F. Hinterberger

Darmstadt, Gesellschaft für Schwerionenforschung (GSI)
U. Lynen, J. Lühning, H. Orth, K. Peters, T.R. Saitoh, C. Schwarz, C. Sfiendi

Dresden, Technische Universität
K.-T. Brinkmann, H. Freiesleben, R. Jäkel

Giessen, Justus Liebig-Universität
M.G. Destefanis, W. Döring, P. Drexler, M. Düren, I. Fröhlich, D.G. Kirschner, W. Kühn,
K. Makonyi, V. Metag, M. Nanova, R. Novotny, F. Ottone, C. Salz, J. Schneider, B. Seitz,
G.-C. Serbanut, H. Stenzel, U. Thöring, M. Thiel

Jülich, Forschungszentrum Jülich (FZJ)
H. Ströher, P. Vlasov, P. Wintz, J. Rittman, D. Grzonka, V. Hejny, W. Gast, A. Gillitzer,
T. Stockmanns, W. Oelert, D. Prasuhn, S. Schadmand, A. Sibirtsev, A. Sokolov, A. Ucar,
M. Drockner, G. Kemmerling, H. Kleines, P. Wüstner

München, Technische Universität
B. Ketzer, I. Konorov, A. Mann, S. Neubert, S. Paul, L. Schmitt, Q. Weitzel

Münster, Westfälische Wilhelms-Universität
D. Frekers, A. Khoukaz, A. Täschner, J. Wessels

Mainz, Johannes Gutenberg-Universität
P. Achenbach, J. Pochodzalla, A. Sanchez-Lorente

Tübingen, Eberhard-Karls-Universität
H. Clement, E. Doroshkevitch, K. Ehrhardt, P. Gonser

Frankfurt, Johann-Wolfgang-Goethe-Universität
R. Dörner, R. Grisenti, M. Kaesz

Erlangen, Friedrich-Alexander-Universität
W. Eyrich, A. Lehmann

- ITALY**
Brescia, Università di Brescia
 A. Zenoni
Catania, Università di Catania and INFN
 M. De Napoli, G. Raciati, E. Rapisarda
Ferrara, Università di Ferrara and INFN
 D. Bettoni, R. Calabrese, P. Dalpiaz, E. Luppi, M. Savriè
Frascati, INFN-Laboratori Nazionali di Frascati
 P. Gianotti, C. Guaraldo, O.N. Hartmann, M. Iliescu, V. Lucherini, E. Pace, C. Petrascu,
 D. Sirghi, F. Sirghi
Genova, INFN
 R. Ballantini, M. Macri, R. Parodi, A. Pozzo
Milano, Politecnico di Milano, Università di Milano and INFN
 P. Alberto, R. Bassini, C. Boiano, I. Iori, S. Riboldi
Pavia, Università di Pavia and INFN
 G. Bendiscioli, G. Boca, A. Fontana, P. Genova, L. Lavezzi, P. Montagna, A. Panzarasa,
 A. Rotond, P. Salvini
Torino, Università del Piemonte Orientale, Alessandria and INFN
 M.L. Colantoni, L. Fava, D. Panziera
Torino, Dipartimento di Fisica Generale 'A. Avogadro', Università di Torino and INFN
 M. Alexeev, A. Amoroso, F. Balestra, R. Bertini, M.P. Bussa, O. Denisov, A. Ferrero,
 L. Ferrero, V. Frolov, R. Garfagnini, A. Grasso, A. Maggiora, M. Maggiora,
 G. Pontecorvo, G. Piragino, F. Tosello, G. Zosi
Torino, Università di Torino, INFN, IFSI and Politecnico di Torino
 M. Agnello, E. Boita, T. Bressani, L. Busso, D. Calvo, P. De Remigis, A. Fellicello,
 F. Ferro, A. Filippi, F. Iazzi, S. Marcello, G. Mazza, O. Morra, A. Rivetti, R. Wheadon
Trieste, INFN and Università di Trieste
 R. Birska, F. Bradamante, S. Dalla Torre, M. Giorgi, A. Martin, P. Schiavon, F. Tessarotto
- POLAND**
Cracow, Uniwersytet Jagielloński
 P. Hawranek, B. Kamys, St. Kistryn, A. Magiera, P. Moskal, B. Piskor-Ignatowicz,
 C. Piskor-Ignatowicz, Z. Rudy, P. Salabura, J. Smyrski, M. Wojciechowski
Katowice, Uniwersytet Śląski
 J. Holeczek, J. Kisiel, B. Klos,
Warsaw, Soltan Institute for Nuclear Studies
 Z. Guzik, M. Kisielinski, T. Kozłowski, D. Melnychuk, J. Wojtkowska, B. Zwięglinski
Otwock-Swierk, Warsaw University of Technology
 B. Slowinski
- SWITZERLAND**
Basel, Universität Basel
 M. Kotulla, B. Krusche, F. Zehr
- RUSSIA**
Gatchina, Petersburg Nuclear Physics Institute of Academy of Science (PNPI)
 S. Belostotski, G. Gavrillov, Y. Naryshkin, O. Miklukho, A. Sarantsev, V. Vikhrov
Nal'chik, Veksler-Baldin Laboratory of High Energies (VBLHE), Joint Institute for Nuclear Research,
Laboratory of Particle Physics (LPP), Laboratory of Information Technologies (LIT),
Laboratory of Nuclear Problems (LNP), Kabardin-Balkarian State University and
Institute of Applied Mathematics and Automation
 V.M. Abazov, G. Alexeev, A. Arefiev, M.Yu. Barabanov, B.V. Batyunya, D. Bogoslovski,
 T.Yu. Bokova, V.V. Borisov, V.A. Budilov, Yu.V. Bugaenko, V.Kh. Dodokhov, A.A. Efremov,
- O.I. Fedorov, A.A. Feshchenko, A.S. Galoyan, G. Ivanov, E. Jafarov, V.I. Kaplin,
 A. Karmokov, E.K. Koshurnikov, V.Ch. Kudaev, V.I. Lobanov, A.F. Makarov,
 L.V. Malinina, V.L. Malyshev, K.V. Mikhailov, B. Morosov, G.A. Mustafaev,
 A.M. Nakhushiev, P.V. Nomokonov, I.A. Oleks, V. Pismennaya, T.A. Pocheptsov,
 A. Polanski, G. Pontecorvo, A. Povtoreyko, Yu.N. Rogov, I.A. Rufanov, S. Ryabitsun, Z.Ya.
 Sadygov, R.A. Salmin, A.G. Samartsev, M.G. Sapozhnikov, T. Sereda, G.S. Shabratova,
 A.A. Shishkin, A.N. Skachkova, N.B. Skachkov, E.A. Strokovsky, R.Sh. Teshev,
 V. Tikhomirov, V.V. Tokmenin, E.P. Ustenko, V.V. Uzhinsky, N.V. Vlasov,
 A.S. Vodopianov, S.A. Zaporozhets, N.I. Zhuravlev, A.I. Zinchenko
Novosibirsk , Budker Institute of Nuclear Physics (BINP)
 E. Baldin, V. Malyshev, A. Maslennikov, S. Peleganchyk, G. Pospelov, A. Sukharev,
 Yu. Tikhonov
Profvino, Institute for High Energy Physics (IHEP)
 E. Ardashhev, Yu. Arestov, G. Britvich, B. Chuiko, S. Golovnya, S. Gorokhov,
 A. Kholodenko, V. Lishin, V. Parakhin, V. Pikalov, V. Shelikhov, A. Vorobiev
Tomsk, Tomsk State University (TSU)
 G. Ayzenshiat, O. Tolbanov, A. Tyazhev
- SPAIN**
Valencia, Universidad de Valencia
 J. Diaz
- SWEDEN**
Stockholm, Kungliga Tekniska Högskolan (KTH)
 B. Cederwall, A. Johnson
Stockholm, Stockholms Universitet
 C. Bargholtz, K. Lindberg, P.E. Tegner, I. Zartova
Uppsala, The Svedberg Laboratory
 H. Calén, C. Ekström, K. Fransson, A. Kupsc, P. Marciniwski
Uppsala, Uppsala Universitet
 F. Cappellaro, B. Höistad, T. Johansson, I. Lehmann, A. Lundborg, Y.-N. Rao,
 Ö. Nordhage, J. Nyberg, H. Pettersson, K. Schömming, P. Thörnrgren Engblom,
 U. Wiedner, J. Zlomanczuk
- UNITED KINGDOM**
Edinburgh, University of Edinburgh
 M. Aliotta, D. Branford, K. Föhl, D. Watts, P. Woods
Glasgow, University of Glasgow
 J. Amund, A. Borissov, D. Ireland, R. Kaiser, J. Kellie, K. Livingston, C. McGeorge,
 D. Protopopescu, G. Rosner
- USA**
Evanston, Northwestern University
 K. Seth
- PAX Collaboration**
ARMENIA
Yerevan, Yerevan Physics Institute
 N. Akopov, R. Avagyan, A. Avetisyan, G. Elbakyan, Z. Hakopov, H. Marukyan,
 S. Tarotian

- BELGIUM**
Gent, University of Gent
 D. Ryckbosch
- CHINA**
Hefei, University of Science and Technology of China
 Y. Jiang, H. Lu, W. Ma, J. Shen, Y. Ye, Z.J. Yin, Y. Zhang
Beijing, Peking University
 B.Q. Ma
- FRANCE**
Palaiseau, Ecole Polytechnique
 B. Pire
- GEORGIA**
Tbilisi State University
 B. Chiladze, N. Lomidze, A. Machavariani, M. Nioradze, T. Sakhelashvili, M. Tabidze,
 I. Trekov, L. Kurdadze, G. Tsirekidze
- GERMANY**
Bochum, Ruhr Universität Bochum
 K. Goeke, A. Metz, P. Schweitzer
Bonn, Helmholtz Institut für Strahlen und Kernphysik
 P.D. Eversheim, F. Hinterberger, U.G. Meißner, H. Rohdteß, A. Sibirtsev
Erlangen, Friedrich-Alexander-Universität
 W. Eyrich, A. Kacharava, A. Lehmann, A. Nass, D. Reggiani, K. Rith, E. Steffens,
 F. Stünzling, P. Tait., S. Vaschenko
Jülich, Forschungszentrum Jülich
 D. Chiladze, R. Gebel, R. Engels, O. Felden, J. Haidenbauer, C. Hanhart, M. Hartmann,
 I. Koshelashvili, S. Krewald, A. Lebrach, B. Lorentz, S. Martin, U.G. Meißner,
 N. Nikolaev, D. Prasuhn, F. Rathmann, R. Schleichert, H. Seyfarth, H. Ströher
**Langenbernsdorf, Unternehmensberatung und Service Büro (USB), Gerlinde
 Schulleis & Partner GbR**
 C. Wiedner (formerly at MPI-K Heidelberg)
- IRELAND**
Dublin, Trinity College
 N. Buttimore
- ITALY**
Alessandria, Università del Piemonte Orientale A. Avogadro and INFN
 V. Barone
Cagliari, Università di Cagliari and INFN
 U. D'Alesio, F. Murgia
Ferrara, Istituto Nazionale di Fisica Nucleare
 M. Capiluppi, G. Ciullo, M. Contalbrigo, A. Drago, P. Ferretti, P. Dalpiaz, F. Giordano,
 P. Lenisa, L. Pappalardo, G. Stancari, M. Stancari, M. Statera
Frascati, Istituto Nazionale di Fisica Nucleare
 E. Aretiusyan, N. Bianchi, E. De Sanctis, P. Di Nezza, A. Fantoni, C. Hadjidakis, D. Hasch,
 M. Mirazita, V. Muccifora, F. Ronchetti, P. Rossi
Lecce, Università di Lecce and INFN
 C. Coriano, M. Guzzi
Milano, Università dell'Insubria and INFN
 P. Ratcliffe
- Torino, Università di Torino and INFN**
 M. Anselmino, M. Boglione, A. Prokudin
- POLAND**
Warsaw, Soltan Institute for Nuclear Studies
 W. Augustyniak, B. Mariani, L. Szymanowski, A. Trzcinski, P. Zupranski
- RUSSIA**
Dubna, Joint Institute for Nuclear Research
 A. Efreimov, O. Teryaev, S. Dymov, N. Kadagidze, V. Komarov, A. Kulikov, V. Kurbatov,
 V. Leontiev, G. Macharashvili, S. Merzliakov, I. Meshkov, V. Serdjuk, A. Sidorin,
 A. Smirnov, E. Syresin, S. Trusov, Y. Uzikov, A. Volkov, N. Zhuravlev, O. Ivanov,
 V. Krivokhizhin, G. Meshcheryakov, A. Nagaytsev, V. Peshkehonov, I. Savin,
 B. Shaikhatdenov, O. Shevchenko, G. Yarygin
Gatchina, Petersburg Nuclear Physics Institute
 S. Barsov, S. Belostotski, O. Grebenyuk, K. Grigoriev, A. Izotov, A. Jgoun, P. Kravtsov,
 S. Manaenkov, M. Mikirtychiants, S. Mikirtychiants, O. Miklukho, Y. Naryshkin,
 A. Vassiliev, A.Zhdanov
Moscow, Institute for Theoretical and Experimental Physics
 V. Baru, A.t Gasparyan, V. Grishina, L. Kondratyuk, A. Kudriavtsev
Moscow, Lebedev Physical Institute
 A. Bagulya, E. Devitsin, V. Kozlov, A. Terkulov, M. Zaveritiaev
Moscow, Moscow Engineering Physics Institute
 A. Bogdanov, S. Nurushev, V. Okorokov, M. Runtzo, M. Strikhanov
Novosibirsk, Budker Institute for Nuclear Physics
 Y. Shatunov
Protvino, Institute of High Energy Physics
 N. Belikov, B. Chujko, Y. Kharlov, V. Korotkov, V. Medvedev, A. Mysnik, A. Prudkoglyad,
 P. Semenov, S. Troshin, M. Ukhanov
- SLOVAKIA**
Kosice, Slovak Academy of Sciences and P.J. Safarik University
 D. Bruncko, J. Ferencei, J. Musinsky, J. Urban
- SWEDEN**
Uppsala, Department of Radiation Sciences
 P. Thornngren-Engblom
- USA**
Brookhaven, Brookhaven National Laboratory
 C. Montag, W. Vogelsang
Chalottesville, University of Virginia
 S. Liuti
Madison, University of Wisconsin
 T. Wise
- HISPEC Collaboration**
ARGENTINA
Buenos Aires, CNEA
 A. Kreiner

- AUSTRALIA**
Canberra, ANU
 G. Dracoulis
- BELGIUM**
Brussels, Université de Bruxelles
 I. Borzow
Leuven, KU Leuven
 P. v. Duppen, M. Huyse, G. Neyens
Louvain-la-Neuve, CRC
 C. Angulo
- DENMARK**
Copenhagen, NBI Copenhagen
 G. Sletten
- FINLAND**
Jyväskylä, JYFL Jyväskylä
 J. Aystö, R. Julin, M. Leino, P. Greenlees
- FRANCE**
Strasbourg, Univ. Strasbourg
 J. Dudek
Saclay, CEA Saclay
 W. Kortien
- GERMANY**
Berlin, HMI
 W. v. Oertzen
Bochum, Ruhr-Universität
 W. Gloeckle
Bonn
 K.H. Speidel
Darmstadt, Gesellschaft für Schwerionenforschung (GSI)
 D. Ackermann, F. Becker, P. Bednarczyk, H. Feldmeier, J. Gerl, M. Gorska, N. Saito,
 T. Saito, Ch. Scheidenberger, M. Tomaselli
Darmstadt, Technische Universität (TUD)
 D. Redondo
Gießen, Justus-Liebig-Universität
 H. Lenske, M. Petrick
Heidelberg, MPI Heidelberg
 H. Scheit
Jülich, Forschungszentrum Jülich (FZJ)
 G. Baur
Cologne, Universität zu Köln
 J. Jolie, P. Reiter, A. Dewald
Munich, Technische Universität München
 R. Krücken
- HUNGARY**
Debrecen, ATOMKI
 Zs. Dombbradi, A. Krasznahorkay, D. Sohler, A. Algóra
- INDIA**
Bhubaneswar, Institute of Physics
 R.K. Choudhury
New Delhi, NSC
 S. Muralithar, S. K. Mandal
- ISRAEL**
Rehovot, Weizman Institute Rehovot
 M. Haas
- ITALY**
Camerino, Università di Camerino
 D. Balabanski
Padova, Università di Padova
 A. Vitturi
- JAPAN**
Osaka, University of Osaka
 Y. Fujita
- NETHERLANDS**
Groningen, KVI
 H. Woertche
- NORWAY**
Bergen, University of Bergen
 J. Vaagen
- POLAND**
Krakow, IFJ PAN Krakow
 A. Maj, J. Styczen, W. Meczynski, G. Grebosz
Warsaw, University of Warsaw
 J. Kowacki
- PORTUGAL**
Lisboa, Universitat Lisboa
 R. Crespo
- ROMANIA**
Bucharest, IFIN-HH
 N.V. Zamfir, D. Bucurescu, G. Cata-Danil, A. Petrovici
- RUSSIA**
Gatchina, PNPI
 Y. Novikov
- SPAIN**
Huelva, University of Huelva
 I. Martel
Madrid, IEM-CSIC
 O. Tengblad, M.J.G. Borge
Madrid, Universita Autonoma de Madrid
 A. Jungclauss, O. Tengblad

Santiago de Compostela, Universita de Santiago
P. Benlliure
Sevilla, Universita Sevilla
J. Gomez-Camacho, J. Espino
Valencia, IFIC, CSIC
B. Rubio

SWEDEN
Stockholm, Royal Institute of Technology
B. Cederwall, A. Johnson
Studsвик, Uppsala University
H. Mach
Uppsala, Uppsala University
J. Nyberg
Lund, University of Lund
D. Rudolph, C. Fahlander

SWITZERLAND
Basel, Universitat Basel
K. Hencken

UNITED KINGDOM
Daresbury, CCLRC Daresbury
J. Simpson, R. Lemmon
Edinburgh, University of Edinburgh
P. Woods
Liverpool, University of Liverpool
P. Nolan, A. Boston, E. Paul
Manchester, University of Manchester
D. Cullen, B. Varley, A. Smith
Paisley, University of Paislay
B. Chapman, K. Spohr, M. Labiche
Surrey, University of Surrey
J. Al-Khalili, Zs. Podolyak, P.M. Walker, P.H. Regan
York, University of York
M. Bentley, D. Jenkins, R. Wadsworth

DESPEC Collaboration

BELGIUM
Leuven, University of Leuven
M. Huyse, G. Neyens, P. van Duppen
Louvain-la-Neuve
C. Angulo

BULGARIA
Sofia
G. Rainovski, S. Lalkovski, M. Danchev

CANADA
Guelph, University of Guelph
P. Garrett

DENMARK
Aarhus
H. Fynbo

FINLAND
Jyväskylä, University of Jyväskylä
J. Äystö, A. Jokinen, P. Jones, R. Julin, M. Leino, H. Penttilä., J. Uusitalo , C. Scholey

FRANCE
Bordeaux
B. Blank
Strasbourg, IRES
G. Duchêne

GERMANY
Darmstadt, Gesellschaft für Schwerionenforschung (GSI)
D. Ackermann, M. Görska, J. Gerl, I. Kojouharov, C. Scheidenberger
Giessen
W. Plass
Köln, Universität Köln
J. Jolie, P. Reiter
Mainz, Universität Mainz
K.-L. Kraatz
München
T. Faestermann, R. Krücken

HUNGARY
Debrecen, Institute of Nuclear Research
A. Algóra

ITALY
Camerino, Universita di Camerino
D.L. Balabanski

NORWAY
Oslo
P. Hoff

POLAND
Krakow, IFJ PAN
A. Męj
Swierk, SINS
E. Ruchowska, S. Kaczarowski
Warsaw, University of Warsaw
W. Kurciewicz, M. Pflutzner

ROMANIA
Bucharest, IFIN-HH
N.V. Zamfir, M. Ionescu-Bujor

RUSSIA
Gatchina, PNPI
L. Batist

St. Petersburg, RI
I. Izosimov

SPAIN

Barcelona, Universita Politècnica Cataluña
F. Calviño
Madrid, CIEMAT
D. Cano-Ott, E. González, T. Martínez
Madrid, Universita Autónoma
A. Jungelaus
Valencia, IFIC, CSIC-Universita Valencia
B. Rubio, J.L. Tañá

SWEDEN

Lund, University of Lund
D. Rudolph
Stockholm
B. Cederwall, A. Johnson
Uppsala, Uppsala University
H. Mach, J. Nyberg

UNITED KINGDOM

Daresbury, CCLRC
J. Simpson, D. Warner, I. Lazarus, V. Pucknell
Edinburgh, University of Edinburgh
P.J. Woods, T. Davinson
Liverpool, University of Liverpool
R. D. Page
Manchester, University of Manchester
D. Cullen
Surrey, University of Surrey
W. Gelletly, Zs. Podolyak, P. Regan, P. Walker

USA

Oak Ridge, ORNL
R. Grzywacz

MATS Collaboration

BELGIUM

Brussels, Université Libre de Bruxelles
P.-H. Heenen

CANADA

Vancouver, TRIUMF
L. Blomley, J. Dilling, V. Ryjkov, M. Smith

FRANCE

Orsay, CSNSM-IN2P3
G. Audi, C. Bachelet, D. Lunney, C. Guénaut

FINLAND

Jyväskylä, University of Jyväskylä
J. Äystö, A. Jokinen, I. Moore

GERMANY

Darmstadt, Gesellschaft für Schwerionenforschung (GSI)
D. Beck, M. Block, H. Geisel, S. Heinz, F. Herfurth, O. Kester, Y.A. Litvinov,
Y.N. Novikov, W. Quint, C. Scheidenberger, M. Winkler, C. Yazdijian
Erlangen, Friedrich-Alexander-Universität
P.G. Reinhard
Garching, Ludwig-Maximilians-Universität
D. Habs, V. Kolhinen, M. Sewtz, J. Szerypo, P.G. Thirolf
Giessen, Justus-Liebig-Universität
T. Dickel, M. Petrick, W. R. Plaf
Greifswald, Ernst-Moritz-Arndt-Universität
M. Breitenfeld, A. Herlert, G. Marx, L. Schweikhard, F. Ziegler
Heidelberg, MPI Kernphysik
J. Ullrich, J.R. Crespo López-Urrutia
Mainz, Johannes-Gutenberg-Universität
K. Blaum, I. Bloch, M. Dworschak, R. Ferrer, S. George, A. Kellerbauer, J. Ketelaer,
S. Kreim, D. Neidherr, W. Nörtershäuser, B. Schabinger, S. Stahl, C. Weber

INDIA

Kolkata, Variable Energy Cyclotron Centre (VECC)
P. Das, A. Ray

SWEDEN

Stockholm, Stockholm University
T. Fritioff, R. Schuch, N. Szilard

USA

East Lansing, Michigan State University
M. Bender, G. Bollen, M. Matos, S. Schwarz
Livermore, Lawrence Livermore National Laboratory
D. Schneider

LaSpec Collaboration

BELGIUM

Leuven, Katholieke Universiteit Leuven
K. Flanagan, M. Huyse, I. Koudriavtsev, G. Neyens, P. Van Duppen

FINLAND

Jyväskylä, JYFL University of Jyväskylä
J. Äystö, A. Jokinen, T. Kessler, I. Moore, K. Peräjärvi

FRANCE

Orsay, IN2P3 CNRS
F. Le Blanc, D. Lunney

GERMANY

Darmstadt, Gesellschaft für Schwerionenforschung (GSI)
Ch. Geppert, Th. Kühl, C. Scheidenberger, M. Tomaselli

Garching, Ludwig-Maximilians-Universität München
D. Habs, M. Sawtz, J. Szerypo, P.G. Thirolf

Heidelberg, MPI Kernphysik
J. R. Crespo López-Urrutia, J. Ullrich

Mainz, Johannes Gutenberg-Universität
K. Blaum, G. Huber, W. Nörtershäuser, M. Seliverstov, K. Wendt

Tübingen, Eberhard-Karls-Universität
C. Zimmermann

GREAT BRITAIN
Manchester, University of Manchester
J. Billowes, P. Campbell

SWITZERLAND
Geneva, CERN
A. Dax

USA
Livermore, Lawrence Livermore National Laboratory
D. Schneider

Richland, Pacific Northwest National Laboratory
B. A. Bushaw

R3B Collaboration

BRASIL
Sao Paulo, Universidade de São Paulo
A. Lepine-Szily

CANADA
Vancouver, TRIUMF
R. Kanungo, I. Tanihata

CHINA
Lanzhou
Y.H. Zhang

DENMARK
Aarhus, University of Aarhus
D. V. Fedorov, H.O.U. Fynbo, A.S. Jensen, K. Riisager

FINLAND
Pyhäsaalmi, CUOPP project
T. Enqvist

FRANCE
Caen, GANIL
D. Brolley, W. Mittig, F. Rejmund, P. Roussel-Chomaz, H. Savajols

Gif sur Yvette, DAPNIA, CEA
A. Boudard, J.-E. Ducret, B. Gastineau, K. Kezzar, E. Le Gentil, V. Lapoux, S. Leray

Lyon, IPN
Ch. Schmitt

Orsay, IN2P3/IPN
F. Azabiz, D. Beaumel, Y. Blumenfeld, B. Genolini, E. Khan, J. Peyré, J. Pouthas,
J.-A. Scarpaci, F. Skaza, T. Zerguerras

GERMANY
Darmstadt, Technische Universität
F. Aksouth, J. Enders, S. Mueller, A. Richter, G. Schrieder, A. Zilges

Darmstadt, Gesellschaft für Schwerionenforschung (GSI)
T. Aumann, F. Becker, K. Boretzky, A. Chaitillon, P. Egelhof, H. Emling, H. Feldmeier,
H. Geissel, J. Gerl, M. Görská, V. Henzl, D. Henzlova, J. Hoffmann, H. Johansson,
A. Kelic, I. Kojouharov, N. Kurz, K. Langanke, T. Le Bleis, Y. Leifels, K. Mahata,
G. Münzenberg, T. Neff, M.V. Ricciardi, T. Saito, K.-H. Schmidt, H. Simon, K. Sümmerer,
W. Trautmann, S. Typel, H. Weick, M. Winkler

Dresden, Forschungszentrum Rossendorf
E. Grosse, A. Junghans, A. Wagner

Frankfurt, Johann Wolfgang Goethe-Universität
C. Müntz, J. Stroth, C. Wimmer

Giessen, Justus-Liebig-Universität
H. Lenske

Heidelberg, Max-Planck-Institut
Heiko Scheit

Köln, Universität zu Köln
P. Reiter

Mainz, Johannes Gutenberg Universität
O. Kiselev, J.V. Kratz

Munich, Technische Universität (TUM)
M. Böhmer, T. Faestermann, J. Friese, R. Gernhäuser, T. Kröll, R. Krücken

HUNGARY
Debrecen, ATOMKI
A. Algora, M. Csatlós, Z. Gácsi, J. Gulyás, M. Hunyadi, A. Krasznahorkay

INDIA
Kolkata, Saha Institute of Nuclear Physics
S. Bhattacharya, U. Datta Pramanik

Mumbai, Tata Institute of Fundamental Research
R. Palit

Mumbai, Bhabha Atomic Research Centre
S. Kailas, A. Shrivastava

JAPAN
Tokyo, Tokyo Institute of Technology
T. Nakamura

POLAND
Krakow, Jagellonski University
P. Adrich, A. Klimkiewicz, R. Kulessa, W. Walus

Krakow, IFJ PAN Krakow
M. Kmiecik, A. Maj, M. Zieblinski

NORWAY
Bergen, University of Bergen
J.S. Vaagen

- ROMANIA**
Bucharest, Institute of Space Sciences
M. Haiduc, D. Hasegan, C. Mitu, M. Pollog, A. Sevenco
- RUSSIA**
Dubna, Joint Institute for Nuclear Research (JINR)
S.N. Ershov, L. Grigorenko
Gatchina, Petersburg Nuclear Physics Institute (PNPI)
A. Khanzadeev
Moscow, Kurchatov Institute
L. Chulkov, B. Danilin
Moscow, Institute for Nuclear Research of RAS
A. Botvina
Obninsk, IPPE Obninsk
A. Ignatyuk
- SPAIN**
Barcelona, Universidad Politecnica de Cataluna
F. Calvino
Madrid, Instituto de Estructura de la Materia, CSIC
M.J.G. Borge, E. Garrido, D. Obradors, O. Tengblad, M. Turrión
Madrid, Universidad Complutense
L.M. Fralle, J.M. Udias
Santiago de Compostela, University of SdC
H. Alvarez-Pol, J. Benlliure, E. Casarejos, D. Cortina-Gil, I. Duran
Valencia, IFIC, CSIC-University Valencia
B. Rubio, J.L. Tain
- SWEDEN**
Göteborg, Chalmers University of Technology
B. Jonson, M. Meister, T. Nilsson, G. Nyman, M. Zhukov
- SWITZERLAND**
Basel, Universität Basel
K. Hencken
- UNITED KINGDOM**
Birmingham, University of Birmingham
M. Freer
Daresbury, CCLRC Daresbury Laboratory
P. Coleman-Smith, I. Lazarus, R. Lemmon, S. Letts, V. Pucknell, J. Simpson
Guildford, University of Surrey
J. Al Khalili, W. Catford, W. Gelletly, R. Johnson, S. Pietri, M. Oi, Z. Podolyak, P. Regan,
P. Stevenson, I. Thompson, J. Tostevin
Liverpool, University of Liverpool
M. Charlier, C.E. Demonchy, B. Fernandez Dominguez, P. Nolan, S. Paschalis
Manchester, University of Manchester
D. Cullen, S. Freeman
Paisley, University of Paisly
R. Chapman, M. Labiche, X. Liang, K. Spohr
York, University of York
Ch. Barton
- USA**
Argonne, Argonne National Laboratory
J. Nolen
East Lansing, MSU
B. Sherrill
New Haven, Yale University
A. Heinz
Tucson, University of Arizona
C. Bertulani
- ILLIMA Collaboration**
- BELGIUM**
Brussels, Université Libre de Bruxelles
K. Takahashi
- CHINA**
Lanzhou, Institute of Modern Physics
R. Mao, Z. Sun, G. Xiao
- FRANCE**
Orsay, CSNSM
G. Audi, D. Lunney
- GERMANY**
Darmstadt, Gesellschaft für Schwerionenforschung (GSI)
E. Badura, K. Beckert, P. Beller, F. Bosch, D. Boutin, A. Dolinski, P. Egelhof,
B. Franczak, B. Franzke, H. Geissel, F. Herfurth, J. Hoffmann, H.-J. Kluge, R.K. Knöbel,
C. Kozhuharov, S.A. Litvinov, Yu.A. Litvinov, G. Münzenberg, F. Montes, I. Nesmiyan,
F. Nickel, F. Nolden, W. Ott, W. Quint, C. Scheidenberger, H. Simon, M. Steck,
Th. Stöhrker, K. Stümmerer, S. Typel, G.K. Vorobjev, H. Weick, M. Winkler
Garching, Technische Universität München
T. Faestermann, P. Kienle, L. Maier, P. Ring, D. Vretenar
Giessen, Justus-Liebig Universität
L. Chen, Z. Di, T. Dickel, A. Fettouhi, M. Petrick, W.R. Plaß
Heidelberg, Max-Planck-Institut für Kernphysik
Th. Bürvenich
Mainz, Johannes Gutenberg Universität
K. Blaum, K.-L. Kraatz, B. Pfeiffer
- GREECE**
Thessaloniki, Aristotle University
G.A. Lalazissis
- JAPAN**
Niigata, Niigata University
T. Ohtsubo
Saitama, University Sakura-ku
T. Yamaguchi
Tsukuba, Tsukuba University
A. Ozawa

- POLAND**
 Warsaw, Warsaw University
 Z. Janas, M. Pfitzner
 Warsaw, Soltan Institute for Nuclear Studies
 Z. Patyk
- RUSSIA**
 Gatchina, St. Petersburg Nuclear Physics Institute and St. Petersburg State University
 Yu.N. Novikov, D.M. Seliverstov, Yu. Gusev
- UNITED KINGDOM**
 Guildford, University of Surrey
 Z. Podolyak, P.M. Walker
 Manchester, University of Manchester
 D. Cullen
- USA**
 East Lansing, Michigan State University
 M. Hausmann, M. Mato, H. Schatz
 Los Alamos, Los Alamos National Laboratory
 D. Madland, P. Moeller, D. Vieira
- AIC Collaboration**
- AUSTRIA**
 Vienna, Stephan Meyer Institut
 E. Widmann, M. Cargnelli, H. Fuhrmann, A. Hirtl, J. Marton, J. Zmeskal
- GERMANY**
 Darmstadt, Gesellschaft für Schwerionenforschung (GSI)
 P. Beller, F. Bosch, B. Frankze, C. Kozhuharov, F. Nolden, Yu. Litvinov
 Giessen, Justus-Liebig Universität
 H. Lenske
 Munich, Technische Universität München
 L. Fabbietti, T. Faestermann, J. Homolka, P.B. Kienle, R. Krücken, P. Ring, K. Suzuki
- JAPAN**
 Saytama, University of Saytama
 T. Yamaguchi
 Tokyo, University of Tokyo
 R.S. Hayano
- POLAND**
 Warsaw, Andrzej Soltan Institute for Nuclear Studies
 S. Wycech
- RUSSIA**
 Novosibirsk, Budker Institute of Nuclear Physics
 Yu. Shatunov, A.N. Skrinsky, V.A. Vostrikov
- ELISE Collaboration**
- GERMANY**
 Darmstadt, Gesellschaft für Schwerionenforschung (GSI)
 T. Aumann, F. Becker, K. Boretzky, A. Dolinskii, P. Egelhof, H. Emling,
 B. Franzke, H. Geissel, A. Kelic, O. Kestler, N. Kurz, G. Münzenberg, F. Nolden,
 K.-H. Schmidt, H. Simon, M. Steck, H. Weick
 Darmstadt, Technische Universität
 J. Enders, T. Nilsson, A. Richter, G. Schrieder, A. Zilges
 Dresden, Forschungszentrum Rossendorf (FZR)
 A.R. Junghans
 Giessen, Justus-Liebig Universität
 H. Lenske
 Mainz, Johannes-Gutenberg-Universität
 H. Merkel, M. Distler, U. Müller
- JAPAN**
 Yamagata, Yamagata University
 S. Kato
 Wako, RI-Beam Science Laboratory
 T. Suda
- NETHERLANDS**
 Groningen, Kernfysisch Versneller Instituut (KVI)
 N. Kalantar-Nayestanaki, H. Wörtche
- RUSSIA**
 Novosibirsk, Budker Institut of Nuclear Physics (BINP)
 I.A. Koop, M.S. Korostelev, P.V. Logatchov, I.N. Nesterenko, A.V. Oboev,
 V.V. Parkhomchuk, V.M. Pavlov, D.N. Shatlov, Yu.M. Shatunov, S.V. Shiyankov,
 A.N. Skrinsky, A.A. Valishev
 Obninsk, Institute of Physics and Power Engineering (IPPE)
 S.P. Kamerdzhiev, E.V. Litvinova
 Dubna, Joint Institute of Nuclear Research, Flerov Laboratory of Nuclear Reactions (JINR)
 A.G. Artukh, V.V. Avdeichikov, S.N. Ershov, L.V. Grigorenko, S.A. Klygin, Yu.M. Sereda,
 Yu.G. Teterov, A.N. Vorontsov
 Dubna, Joint Institute of Nuclear Research, Laboratory for Nuclear Problems (JINR)
 I.N. Meshkov, E.M. Syresin, I.A. Seleznev
 Moscow, Kurchatov Institute
 L.V. Chulkov, B.V. Danilin, V.A. Volkov
 Moscow, Institute for Nuclear Research
 V.G. Nedorezov, V.P. Lisin, A.A. Turling, A.L. Polonski, A.N. Mushkarenkov, N.V. Rudnev
- SPAIN**
 Madrid, Instituto de Estructura de la Materia (CSIC)
 R. Alvarez, M.J.G. Borge, E. Garrido, E. Moya de Guerra, C.F. Ramirez, P. Sarriguren
 Sevilla, University of Sevilla
 J.A. Caballero
 Granada, University of Granada
 E. Amaro, A. Lallena
 Madrid, Universidad Complutense
 L.V. Fraile, J.L. Herranz, J.M. Udias Moimelo, J.R. Vignote

- SWEDEN**
Göteborg, Chalmers Tekniska Högskola and Göteborgs Universitet
 H. Johansson, B. Jonson, G. Nyman
- SWITZERLAND**
Basel, Universität Basel
 K. Hencken, J. Jourdan, B. Krusche, F. Rauscher, D. Rohe, D. Trautmann
- UNITED KINGDOM**
Darshury, Daresbury Laboratory
 R. Lemmon
Guildford, University of Surrey
 W. Catford, J. Al-Khalil, R. Johnson, P. Stevenson
Liverpool, University of Liverpool
 M. Chartier
Manchester, University of Manchester
 D. Cullen
York, University of York
 C. Barton, D. Jenkins
- USA**
New Haven, Wright Nuclear Structure Laboratory (WNSL)
 A. Heinz
Tucson, University of Arizona
 C. Bertulani
- EXL Collaboration**
- BRASIL**
São Paulo, Universidade de São Paulo
 A. Lépine-Szilý
- CANADA**
Vancouver, TRIUMF
 R. Kanungo
- FRANCE**
Orsay, Institut de Physique Nucléaire (IPNO)
 D. Beaumel, Y. Blumenfeld, E. Khan, J. Peyre, J. Pouthas, J.A. Scarpaci, F. Skaza, T. Zerguerras
Saclay, CEADAPNIA
 F. Auger, A. Drouart, A. Gillibert, L. Nalpas
- GERMANY**
Darmstadt, Gesellschaft für Schwerionenforschung (GSI)
 T. Aumann, F. Becker, K. Becker, P. Beller, K. Boretzky, A. Dolinski, P. Egelhof, H. Emiling, H. Feldmeier, B. Franczak, H. Geissel, J. Gerl, C. Kozhuharov, Y. Litvinov, J.P. Meier, T. Neff, F. Nolden, C. Peschke, U. Popp, H. Reich-Sprenger, H. Simon, M. Steck, T. Stöhlker, K. Summerer, S. Typel, H. Weick, M. Winkler
Darmstadt, Technische Universität
 T. Nilsson, G. Schröder
Frankfurt, Johann Wolfgang Goethe-Universität
 R. Dörner, R. Grisenti, J. Stroth
- Jülich, Institut für Kernphysik, Forschungszentrum Jülich (FZJ)**
 D. Grzonka, T. Krings, D. Prodic, F. Rathmann
Mainz, Johannes Gutenberg Universität
 O. Kiselev, J.V. Kratz
Munich, Technische Universität München
 M. Böhmer, T. Faestermann, R. Gernhäuser, P. Kienle, R. Krücken, L. Maier, K. Suzuki
- HUNGARY**
Debrecen, Institute of Nuclear Research (ATOMKI)
 A. Algora, M. Csátos, Z. Gáski, J. Gulyás, M. Hunyadi, A. Krasznahorkay
- INDIA**
Kolkata, India, Saha Institute of Nuclear Physics
 S. Bhattacharya, U. Datta Pramanik
Mumbai, Bhabha Atomic Research Center (BARC)
 S. Kailas, A. Shrivastava
- IRAN**
Tehran, University of Tehran
 M. Mahjour-Shafiei
- ITALY**
Milan, Università da Milano and INFN
 A. Bracco, P.F. Bortignon, G. Coló, A. Zalite
- JAPAN**
Osaka, Osaka University
 Y. Fujita
- NETHERLANDS**
Groningen, KVI
 M.N. Harakeh, N. Kalantar-Nayestanaki, H. Wörtche
- SWITZERLAND**
Basel, Universität Basel
 K. Hencken, J. Jourdan, B. Krusche, T. Rauscher, D. Rohe, F. Thielemann
- RUSSIA**
Dubna, FLNR Joint Institute of Nuclear Research
 A.G. Artukh, S.A. Klygin, G.A. Kononenko, Yu.M. Sereda, E.A. Shevchik, Yu.G. Teterev, A.N. Vorontzov
Gatchina, St. Petersburg Nuclear Physics Institute and St. Petersburg State University (PNPI)
 V. Ivanov, A. Khanzadeev, E. Rostchin, O. Tarasenkova, Y. Zalite
Moscow, Kurchatov Institute
 L. Chulikov
St. Petersburg, V.G. Khlopin Radium Institute
 Y. Murin
- SPAIN**
Madrid, Instituto de Estructura de la Materia (CSIC)
 E. Garrido, O. Moreno, P. Sarriguren, J. R. Vignote
Madrid, Universidad Complutense
 L. Fralle, J. López Herranz, E. Moya de Guerra, J.M. Udias, C. Martínez-Pérez

SWEDEN

Göteborg, Chalmers Institute
 B. Jonsson, T. Nilsson, G. Nyman
 Lund, Lund University
 V. Avdeichikov, L. Carlén, P. Gobulev, B. Jakobsson
 Sundsvall, Mid Sweden University
 G. Thungström
 Uppsala, Svedberg Laboratory (TSL)
 C. Ekström, L. Westerberg

UNITED KINGDOM

Birmingham, University of Birmingham
 M. Freer
 Daresbury, CCLRC Daresbury Laboratory
 P. Coleman-Smith, I. Lazarus, R. Lemmon, S. Letts, V. Pucknell
 Guildford, University of Surrey
 J. Al-Khalili, W. Catford, R. Johnson, P. Stevenson, I. Thompson
 Hestington, University of York
 C. Barton, B. Fulton, D. Jenkins, A. Laird
 Liverpool, University of Liverpool
 M. Chartier, J. Cresswell, B. Fernandez Dominguez, J. Thornhill

SPARC Collaboration

ARGENTINA

Río Negro, Centro Atómico Bariloche
 P.D. Fainstein

AUSTRIA

Vienna, Technische Universität Wien
 J. Burgdoerfer, C. Lemell, S. Yoshida, F. Aumayr, H. Winter

CANADA

Winnipeg, University of Manitoba
 G. Gwinner
 Toronto, York University
 M. Horbatsch
 Vancouver, TRIUMF National Laboratory
 J. Dilling

CHINA

Beijing, China Institute of Atomic Energy
 X. Zeng
 Beijing, Institute of Applied Physics and Computational Mathematics
 J. Wang
 Hefei, University of Science and Technology of China
 J. Chen, L.F. Zhu
 Jilin, Jilin University
 D. Ding
 Lanzhou, Chinese Academy of Sciences
 X. Cai, X. Ma, B. Wei, F. S. Zhang, X. Zhu
 Lanzhou, Lanzhou University
 C. Ximeng

Lanzhou, Northwest Normal University

C. Dong
 Shanghai, Fudan University
 C. Chen, Y.Zou
 Wuhan, Wuhan Institute of Physics and Mathematics
 K. Gao

CROATIA

Zagreb, Ruder Boskovic Institute
 K. Pisk, T. Suric

CZECH REPUBLIC

Prague, Czech Academy of Sciences
 O. Renner

DENMARK

Aarhus, University of Aarhus
 L.B. Madsen

EGYPT

Beni-Suef, Faculty of Science
 H. Hanafy, T. Mohamed

FRANCE

Caen, CIRIL Ganil
 B. Mami, H. Rothard
 Lyon, Ecole Normale Supérieure
 A. Simonovici
 Lyon, Institut de Physique Nucléaire de Lyon
 D. Dauvergne
 Paris, Groupe de Physique des Solides
 E. Lamour, J.P. Rozet
 Paris, Université P. & M. Curie et Ecole Normale Supérieure
 E.O. Le Bigot
 Paris, Laboratoire Kastler-Brossel (UPMC/ENS)
 D. Attia

GERMANY

Berlin, Hahn-Meitner-Institut
 J. Eichler
 Berlin, Humboldt-Universität
 A. Saenz
 Braunschweig, Physikalisch-Technische Bundesanstalt
 V. Dangendorf
 Clausthal-Zellerfeld, Technische Universität
 T. Kirchner
 Darmstadt, Gesellschaft für Schwerionenforschung (GSI)
 D. Beck, F. Becker, T. Beier, H.F. Beyer, M. Block, F. Bosch, A. Braeuning-Demian,
 C. Brandau, P. Egelhof, A. Gumberidze, T. Hahn, F. Herfurth, H.J. Kluge,
 C. Kozhuharov, T. Kühl, D. Liesen, R. Mann, P. Mokler, M. Mukherjee, W. Quint,
 S. Rahaman, R. Sanchez, H. Simon, T. Stöhlker, M. Tomasselli, S. Trotsenko, C. Weber
 Darmstadt, Technische Universität
 A. Zhiges

- Dresden, Technische Universität**
O.Yu. Andreev, G. Plumien, R. Schützhold, G. Soff, A. Volotka
Erlangen, Friedrich-Alexander-Universität
G. Zwicknagel
Frankfurt, Johann Wolfgang Goethe-Universität
R. Dörner, R. Grisenti, S. Hagmann, H. Schmidt-Böcking, K.E. Stiebing
Freiburg, Albert-Ludwigs-Universität
J. Briggs, U. Jentschura
Gießen, Justus-Liebig-Universität
H. Bräuning, A. Müller, S. Schippers, W. Scheid
Heidelberg, Max-Planck-Institut für Kernphysik
D. Fischer, C.H. Keitel, M. Lestinsky, R. Moshhammer, S. Reinhardt, G. Saathoff,
F. Sprenger, J. Ullrich, C. Welsch, A. Wolf, A. Voitkv
Heidelberg, Kirchhoff-Institut für Physik
A. Fleischmann
Jena, Friedrich-Schiller-Universität
E. Förster
Jülich, Forschungszentrum Jülich (FZJ)
A. Herler, G.H. Marx, L. Schweikhard, G. Baur, D. Gottia, T. Krings, D. Proftic,
F. Rathmann
Kassel, Universität Kassel
J. Anton, B. Fricke, S. Fritzsche, W. D. Sepp, A. Surzhykov
Mainz, Johannes-Gutenberg-Universität
W. Nörtershäuser, H. Backe, S. Djekic, G. Huber, S. Karpuk, C. Novotny, S. Stahl,
M. Vogel
Munich, Ludwig-Maximilians-Universität
D. Habs, U. Schramm, D. Jakubassa-Amundsen
Rostock, Universität Rostock
G. Röpke
- GREECE**
Heraklion, University of Crete and IESL-FORTH
T. Zouros
- HUNGARY**
Debrecen, Institute of Nuclear Research (ATOMKI)
B. Sulik, K. Tokesi
- INDIA**
Kolkata, Saha Institute of Nuclear Physics
D. Mitra
Mumbai, Tata Institute of Fundamental Research
K. Manchikani, D. Mathur, L. Tribedi, U.Kadhane
New Delhi, Nuclear Science Centre
T. Nandi, C.P. Safvan
New Delhi, Bhabha Atomic Research Centre
B. Suri
Rohtak, Vaish College
P. Verma
- ITALY**
Catania, Istituto Nazionale di Fisica Nucleare (INFN)
G. Lanzano
- JAPAN**
Wako, University of Tokyo and RIKEN
Y. Yamazaki
- JORDAN**
Zarqa, Hashemite University
F. Afaneh, R. Ali
- MEXICO**
Mexico City, Universidad Nacional Autónoma de México
C. Cisneros
- NETHERLANDS**
Groningen, Rijks Universiteit
R. Hoekstra, R. Morgenstern, A. Robin
- POLAND**
Cracow, Jagiellonian University
S. Samek, A. Warczak
Cracow, Institute of Nuclear Physics of Polish Academy of Sciences
Z. Stachura
Kielce, Swietokrzyska Academy
D. Banas, M. Pajek
Swierks, Soltan Institute for Nuclear Studies
J. Rzadkiewicz
Warsaw, Warsaw University
K. Pachucki
- ROMANIA**
Bukarest, National Institute for Physics and Nuclear Engineering (NIPNE)
C. Giordea, D.E. Dumitriu, A. Enulescu, D. Filuerasu, L.C. Penescu, A.T. Radu
- RUSSIA**
Moscow, Lebedev Physical Institute
L.Presnyakov, V. Shevelko
Moscow, Institute of Metrology for Time and Space at VNIIFTR
V. Pal'Chikov
Moscow, Institute of Spectroscopy of the RAS
L.Bureyeva
Moscow, State University
V.Balashov
Moscow, RRC Kurchatov Institute
V. Lisitsa
St. Petersburg, State University
O.Y. Andreev, A. Artemyev, I. Goidenko, L.N. Labzowsky, A. Nefitov, V. Shabaev,
V. Yerokhin
St. Petersburg, V.G.Khlopin Radium Institute
V. Varentsov
St. Petersburg, Nuclear Physics Institute
E. Drukarev
- SERBIA AND MONTENEGRO**
Belgrade, Institute of Physics
B. Marinkovic

- SPAIN**
Madrid, CSIC
 G. Garcia
- SWEDEN**
Goteborg, Chalmers University of Technology and Goteborg University
 I. Lindgren, S. Salomonson
Lund, Lund University
 R. Hutton
Stockholm, Manne Siegbahn Laboratory MSL
 G. Andler, L. Bagge, H. Danared, M. Engström, A. Källberg, L. Liljeby, P. Löfgren,
 A. Paál, K.-G. Rensfelt, A. Simonsson, Ö. Skeppstedt
Stockholm, Stockholm University
 E. Lindroth, S. Madzunkov, S. Nagy, R. Schuch, G. Viktor
Sundsvall , Mid-Sweden University
 G. Peter
- SWITZERLAND**
Basel, Universität Basel
 K. Hencken, D. Trautmann
Fribourg, Université de Fribourg
 J.-C. Dousse, M. Kavcic, J. Szlachetko
- UNITED KINGDOM**
Belfast, Queen's University
 F. Currell, J. Walters
Durham, University of Durham
 R. Potvillege
London, Imperial College
 D. Segal, R. Thompson, D. Winters
- USA**
Atlanta , Georgia State University
 Steven Manson
Austin, University of Texas
 E. Gaul
Berkeley, Lawrence Berkeley National Laboratory (LBL)
 T. Schenkel, D. Schneider, S. Toleikis
Boston, Harvard-Smithsonian Center for Astrophysics
 E. Silver
Kalamazoo, Western Michigan University,
 E. Kamber, J. Tanis
Manhattan, Kansas State University
 P. Richard
New York, Columbia University
 D. W. Savin
Norfolk, Old Dominion University
 C. Whelan
Oak Ridge, Oak Ridge National Laboratory (ORNL)
 M. Fogle, J. Macek
Providence, Brown University
 C. Enss
Rolla , University of Missouri
 R. DuBois, M. Schulz
- UZBEKISTAN**
Tashkent, Uzbek Academy of Sciences
 D. Matrasulov, K. Rakhimov
- HEDGEHOB Collaboration**
- CHINA**
Shanghai, Institute for Optics and Fine Mechanics (IOFM)
 R. Li, Q.H. Lou, B. Shen, W. You, J.Q. Zhu
- CZECH REPUBLIC**
Prague, Pals Research Center
 K. Jungwirth, M. Kalal, J. Ullschmied
- FRANCE**
Marseille, Université de Provence
 F.B. Rosmej, R. Stamm
Orsay, Laboratoire de Physique des Gaz et des Plasmas (LPGP)
 C. Deutsch, G. Maynard
Palaiseau, Laboratoire pour l'Utilisation des Lasers Intenses (LULI)
 P. Audebert, E. Brambrink, N. Grandjean
Talence, Université de Bordeaux
 J.-C. Gauthier, G. Schurtz, V. Tikhonchuk
- GERMANY**
Bochum, Ruhr Universität
 H. Ruhl
Darmstadt, Technische Universität (TUD)
 D.H.H. Hoffmann, R. Knobloch, P. Ni, M. Roth, G. Schaumann, M. Schollmeier, S. Udrea,
 D. Varentsov
Darmstadt, Gesellschaft für Schwerionenforschung (GSI)
 A. Blazevic, R. Bock, S. Borneis, T. Kühl, R. Neumann, O. Rosmej, N.A. Tahir,
 A. Tauschwitz, C. Trautmann,
 H. Wahl, K. Weyrich
Erlangen, Friedrich-Alexander-Universität
 C. Toepffer, G. Zwicknagel
Frankfurt, Johann-Wolfgang-Goethe Universität
 A. Adonin, J. Jacoby, An. Tauschwitz
Garching, Max-Planck-Institut für Quantenoptik
 J. Meyer-ter-Vehn
Greifswald, Ernst-Moritz-Arndt-Universität
 D.O. Gericke, G. Grubert, M. Schlanges, J. Vorberger
Jena, Friedrich-Schiller-Universität
 R. Sauerbrey
Munich, Ludwig-Maximilians-Universität
 D. Habs
- Rostock, Universität Rostock**
 C. Fortmann, H. Juraneck, A. Kietzmann, S. Kuhlbrodt, N. Nettelmann, B. Omar,
 R. Redmer, H. Reinholz, G. Röpke, V. Schwarz, R. Thiele
- ISRAEL**
Rehovot, Weizmann Institute of Sciences
 V. Fisher, Y. Maron, E. Nardi, A. Starobinets, K. Tsigitkin

- ITALY**
Frascati, Research Centre (ENEA)
 A. Caruso
Milano, University of Milano
 D. Batani
- JAPAN**
Tokyo, Tokyo Institute of Technology
 M. Ogawa
- KOREA**
Changwon, Korea Electrotechnology Research Institute
 H. Suk
Daejon, Korea Advanced Institute of Science and Technology (KAIST)
 H.J. Kong
Daejeon, Korea Atomic Energy Research Institute
 Ch.J. Kim, Ch. Lim
- RUSSIA**
Chernogolovka, Institute of Problems of Chemical Physics
 S. Dudin, V.E. Fortov, V.K. Gryaznov, G.I. Kanel, V.V. Kim, M. Kulish, I.V. Lomonosov,
 A.V. Matveichev, V.B. Mintsev, D.N. Nikolaev, V.I. Postnov, S.V. Razorenov, A. Sheyko,
 N. Shilkin, A.V. Shutov, V. Sosikov, V.G. Sultanov, V.Ya. Ternovoi, A.V. Utkin, D. Yuryev,
 Yu. Zaporoghets
- Moscow, Institute of High Energy Density**
 E.M. Apfelbaum, V.P. Eifremov, K.V. Khishchenko, P.R. Levashov, V.V. Milyavskii,
 I.V. Morozov, G.E. Norman, M.E. Povarnitsyn
- Moscow, Institute for Theoretical and Experimental Physics (ITEP)**
 M.M. Basko, A. Fertman, A.A. Golubev, S. Minaev, I. Roudskoy, B. Yu. Sharkov,
 V. Turtikov
- Moscow, RRC Kurchatov Institute**
 Yu.G. Kalinin, A.S. Kingssep, L.S. Lisitsa, V.P. Smirnov
- Saroy, All-Russian Institute of Experimental Physics (VNIIEF)**
 M.V. Zhernokletov
- Mendeleevo, Multi-Charged Ion Spectra Data Center (MISDC) of VNIIFTRI**
 A.Ya. Faenov, A.I. Magunov, T.A. Pikuz, I.Yu. Skobelev
- Moscow, Institute of Physics and Technology**
 I. Iosilevski
- Moscow, Lebedev Physical Institute**
 I. Aleksandrova, V. Chitchebakov, A. Gromov, E. Koresheva, E. Koshelev, A. Kupriashin,
 Y. Merkuliev, A. Nikitenko, I. Osipov, T. Timasheva, S. Tolokonnikov
- SPAIN**
Ciudad Real, Universidad de Castilla La Mancha
 M. Barigga, A. Bret, O.D. Cortazar, J.J. Lopez-Cela, A.R. Piriz, J.C. Sanchez-Duque,
 M. Temporal, J.G. Wouchuk
- Valencia, Universidad Politecnica**
 J.A. Alcober Auban, D. Ballester, I.M. Tkachenko Gorski
- SWITZERLAND**
Geneva, European Organization for Nuclear Research (CERN)
 V. Kain, R. Schmidt
- UKRAINE**
Odessa, National University
 V.M. Adamyan
- UNITED KINGDOM**
Belfast, Queens University (QUB)
 D. Ritley, M. Zepf
- USA**
Albuquerque, Sandia National Laboratories (SNL)
 M. Geissel, T. Mehlhorn, J. Porter
Berkeley, Lawrence Berkeley National Laboratory (LBL)
 G. Logan
Livermore, Lawrence Livermore National Laboratory (LLNL)
 D. Callahan, C. Constantin, E. Dewald, A. Friedman, S.H. Glenzer, C. Niemann,
 M. Tabak
Los Alamos, Los Alamos National Laboratory (LANL)
 J.F. Benage, J. Fernandez, M. Hegelich, M.S. Murrillo
Princeton, Princeton University
 R. Davidson
Reno, University of Nevada (UNR)
 T. Cowan, P. Wiewior
- WDM Collaboration**
- FRANCE**
Marseille, Université de Provence et CNRS
 F.B. Rosmej, R. Stamm
Orsay, Université Paris XI et CNRS
 G. Maynard, B. Cros
Palaiseau, Laboratoire d'Optique Appliquée
 P. Zeitoun
- GERMANY**
Darmstadt, Gesellschaft für Schwerionenforschung (GSI)
 S. Borneis, Andreas Tauschwitz, T. Kühl, E. Onkels, S. Götte, T. Schlegel,
 D.H.H. Hoffmann, H. Wahl, K. Weyrich, H.-J. Kluge
Frankfurt, Johann-Wolfgang-Goethe Universität
 J. Jacoby, A. Adonin, J. Maruhn, A. Tauschwitz
Heidelberg, Max-Planck Institut für Kernphysik
 J. Ullrich
Rostock, Universität Rostock
 R. Redmer
- JAPAN**
Osaka, Institute of Laser Engineering (ILE)
 H. Nishimura, K. Nagai, T. Norimatsu
Saitama, Institute of Physical and Chemical Research (RIKEN)
 Y. Yamazaki
- RUSSIA**
Moscow, RRC Kurchatov Institute
 V.S. Lisitsa, A. Demura

- Mendeleevo , Multi-Charged Ion Spectra Data Center (MISDC) of VNIIFTRI**
A.Ya. Faenov, T.A. Pikuz
- Moscow, Institute for Theoretical and Experimental Physics (ITEP)**
M. Basko, A. Golubev, A. Fertmann, V. Turtikov, B. Sharkov
- Moscow, Lebedev Physical Institute**
L.A. Vainshtein, I. Beigman, I.Yu. Tolstikhina, E.R. Koresheva, I.E. Osipov,
I.V. Aleksandrova, Yu.A. Merkuliev, A.I. Gromov, T.P. Timasheva, E.L. Koshelev,
S.M. Tolokonnikov, V.I. Chicherbakov, A.I. Nikitenko
- St. Petersburg, State Polytechnic University**
V.Y. Sergeev, V.G. Kapralov, B.V. Kuteev, D.V. Kizivetter, A.Yu. Kostrukov
- UNITED KINGDOM**
- Belfast, Queens University (QUB)**
D. Riley
- USA**
- Livermore, Lawrence Livermore National Laboratory (LLNL)**
R.W. Lee
- Los Alamos, Los Alamos National Laboratory (LANL)**
J. Abdallah Jr
- FLAIR Collaboration**
- AUSTRIA**
- Vienna, Stefan Meyer Institute for Subatomic Physics**
M. Cargnelli, H. Fuhrmann, P. Kienle, H. Marton, E. Widmann, H. Zmeskal
- Vienna, University of Technology**
J. Burgdoerfer, C. Lemell, S. Yoshida
- CANADA**
- Toronto, York University**
E. A. Hessels
- Vancouver, Triumf**
M.C. Fujiwara
- DENMARK**
- Aarhus, Institute for Storage Ring Facilities**
S. P. Møller
- Aarhus, Aarhus University**
H. Knudsen, U. I. Uggerhøj
- FRANCE**
- Paris, École Normale Supérieure et Université P. et M. Curie**
É.-O. Le Bigot, S. Boucard, P. Indelicato
- GERMANY**
- Berlin, Humboldt Universität**
A. Saenz
- Darmstadt, Gesellschaft für Schwerionenforschung (GSI)**
T. Beier, H. Beyer, M. Block, F. Bosch, S. Borneis, A. Bräuning-Demian, B. Franzke,
S. Hagemann, F. Herfurth, A. Kellerbauer, H.-J. Kluge, C. Kozhuharov, T. Kühl,
D. Liesen, R. Mann, P. Mokler, F. Nolden, H. Orth, W. Quint, M. Steck, T. Stöhlker,
M. Tomaselli
- Dresden, Technische Universität**
G. Plunien, G. Soff
- Frankfurt, Johann-Wolfgang-Goethe Universität**
U. Ratzinger, A. Schempp, R. Dörner,
- Giessen, Justus-Liebig Universität**
A. Müller
- Heidelberg, MPI für Kernphysik**
M. Griesser, R. von Hahn, T. Ichioaka, U. Jentschura, R. Moshhammer, J. Ullrich,
C.P. Welsch, A. Wolf
- Jülich, Forschungszentrum Jülich (FZJ)**
A. Gillitzer, D. Gotia, D. Grzonka, K. Kilian, W. Oelert, J. Ritman
- Mainz, Johannes-Gutenberg Universität**
K. Blaum, I. Bloch, S. George, S. Stahl, M. Vogel, J. Walz, C. Weber, G. Werth,
W. Nörtershäuser
- HUNGARY**
- Budapest, Research Institute for Particle and Nuclear Physics (KFKI)**
D. Barna, D. Horvath
- Debrecen, Institute of Nuclear Research of the Hungarian Academy of Sciences (ATOMKI)**
B. Juhász, B. Horváth, E. Takács, K. Tökési
- Debrecen, University of Debrecen**
E. Takacs
- INDIA**
- Kolkata, Variable Energy Cyclotron Center (VECC)**
A. Ray
- ITALY**
- Brescia, Università di Brescia and INFN**
M. Corradini, M Leali, E. Lodi Rizzini, L. Venturelli, N. Zurlo
- Firenze, Università degli Studi di Firenze and INFN**
G. M. Tino
- Genova , Istituto Nazionale di Fisica Nucleare (INFN)**
G. Testera
- JAPAN**
- Wako, Atomic Physics Laboratory (RIKEN)**
Y. Kanai, N. Kuroda, A. Mohri, Y. Nagata, H. Saito, M. Shibata, M. Wada
- Wako, Atomic Physics Laboratory (RIKEN) and University of Tokyo**
Y. Yamazaki
- Tokyo, University of Tokyo**
A. Dax, R.S. Hayano, M. Hori, T. Ishikawa, K.-I. Komaki, H. A. Torii
- NETHERLANDS**
- Amsterdam, Laser Centre Vrije Universiteit**
K.S.E. Eikema, W. Hogervorst, W. Ubachs
- Amsterdam, FOM Institute for Atomic and Molecular Physics**
L.D. Noordam
- POLAND**
- Warsaw, Warsaw University**
J. Jastrzebski, A. Trzcinska, K. Pachucki

- Warsaw, Soltan Institute for Nuclear Studies**
S. Wycech
- RUSSIA**
Dubna, Joint Institute for Nuclear Research (JINR)
I. Meshkov, I. Seleznev, A. Smirnov, A. Sidorin, E. Syresin, G. Trubnikov, S. Yakovenko, Yu. Korotaev, A. Kobets
Moscow, State University
V.V. Balashov
Moscow, Institute of Theoretical and Experimental Physics (ITEP)
S. Minaev
St. Petersburg, D.I. Mendeleev Institute for Metrology (VNIIM),
S. G. Karshenboim
St. Petersburg, State University
L. N. Labzowsky, V. M. Shabaev
St. Petersburg, Nuclear Physics Institute
A.V. Nefiodov
Troitsk, Institute of Spectroscopy of the RAS
L.A. Bureyeva
- SWEDEN**
Stockholm, Manne Siegbahn Laboratory (MSL)
G. Andler, L. Bagge, H. Danared, M. Engström, A. Källberg, L. Liljeby, P. Löfgren,
A. Paál, K.-G. Rensfelt, A. Simonsson, Ö. Skeppstedt
Stockholm, Stockholm University
R. Schuch, E. Lindroth
- UNITED KINGDOM**
Belfast, Queens University
R. McCullough
Swansea, University of Wales
M. Charlton, N. Madsen
- USA**
Albuquerque, University of New Mexico
B. Bassalleck
Bloomington, Indiana University
Alan Kostelecky
Cambridge, Harvard University
G. Gabrielse
Cambridge, Massachusetts Institute of Technology (MIT) and Duke University (NC)
P. Kingsberry
College Station, Texas A&M University
H.A. Schuessler
Santa Fe, Pbar Labs
M.H. Holzschetter, C. Maggiore
- Biophysics Collaboration**
FINLAND
Turku, University of Turku
E. Valtonen
- GERMANY**
Braunschweig, Phys.-Techn. Bundesanstalt (PTB)
H. Schuhmacher
Darmstadt, Gesellschaft für Schwerionenforschung (GSI)
D. Schardt, M. Scholz, S. Ritter, H. Iwase, T. Elsässer, G. Kraft
Köln, Deutsches Inst. f. Luft-und Raumfahrt (DLR)
G. Reitz
- IRELAND**
Dublin, Institute for Advanced Studies
D. O'Sullivan
- ITALY**
Milano, University of Milano
D. Bettega
Naples, University of Naples
M. Durante
Rome, University of Rome
L. Narici, P. Picozza
Torino, Istituto Nazionale di Fisica Nucleare (INFN)
R. Cirio
- JAPAN**
Chiba, National Institute of Radiation Science (NIRS)
R. Okayasu
- RUSSIA**
Dubna, Joint Institute for Nuclear Research (JINR)
E. Krasavin
Moscow, Institute of Theoretical and Experimental Physics (ITEP)
A. Golubev
- SWEDEN**
Göteborg, Chalmers University of Technology
L. Silver
- USA**
Berkeley, Lawrence Berkeley Lab (LBL)
J. Miller
Cambridge, Massachusetts Institute of Technology (MIT)
S.C.C. Ting
Pasadena, California Institute of Technology (CALTECH),
R. Mewaldt
- Materials Research Collaboration**
- CHINA**
Lanzhou, Institute of Modern Physics (IMP-CAS)
G.M. Jin, J. Liu, Z.G. Wang
- FRANCE**
Caen, Centre Interdisciplinaire de Recherche Ions Laser (CIRIL)
A. Benyagoub, S. Bouffard, H. Rothard, M. Toulemonde

GERMANY
Bayreuth, Universität Bayreuth und Bayerische Akademie der Wissenschaften
H. Kepler
Berlin, Hahn-Meitner-Institut (HMI)
S. Klaumünzer, G. Schiwietz
Darmstadt, Technische Universität
D. H. Hoffmann, D. Varentzov, S. Udrea
Darmstadt, Gesellschaft für Schwerionenforschung (GSI)
R. Neumann, C. Trautmann, M. Lang, H. Geissel, N. Tahir
Frankfurt, Johann-Wolfgang-Goethe-Universität
S. Hagmann
Heidelberg, Heidelberger Akademie der Wissenschaften
G.A. Wagner
Heidelberg, Max-Planck-Institut für Kernphysik
U.A. Glasmacher
Heidelberg, Ruprecht-Karls Universität
R. Miletich
Jena, Friedrich-Schiller-Universität
F. Langenhorst
Stuttgart, Universität Stuttgart
W. Bolse

JAPAN
Osaka, Osaka Prefecture University
A. Iwase
Tokai, Japan Atomic Energy Research Institute (JAERI)
Y. Chimi, N. Ishikawa
Wako, RIKEN
T. Kambara

Publisher and copyright

Gesellschaft für Schwerionenforschung mbH (GSI)
Member of the Hermann-von-Helmholtz-Association of National Research Centres (HGF)
Planckstraße 1
64291 Darmstadt
GERMANY

Phone +49-(0)6159-71-0
Fax +49-(0)6159-71-3916
Mail FAIR@gsi.de

Publication Date

September 2006

Print

Digitaldruck leibi.de
Schindowski Zimmermann GbR
89233 Neu-Ulm

Design

Bauer & Guse GmbH
64367 Mühlthal

ISBN 3-9811298-0-6
EAN 978-3-9811298-0-9



Gesellschaft für Schwerionenforschung mbH



