

INJECTOR OF PRIMARY SOLUTIONS WITH HYDRAULIC CONTROL

Gheorghe ȘOVĂIALĂ¹, Sava ANGHEL¹, Gabriela MATACHE¹, Ana-Maria POPESCU¹,
Petru-Marian CÂRLESCU²

e-mail: sovaiala.ihp@fluidas.ro

Abstract

The injector within the structure of the equipment usable for fertigation of horticultural crops, developed under the PN-II-PT-PCCA-2013-4-0114-*FERTIRIG* project, Financial Agreement no. 158 /2014, is the type double diaphragm pump, compact design, its body embedding both the hydraulically controlled directional valve, which controls the change in the direction of motion of the mobile assembly with membranes, and the valves for intake/ discharge of primary solution. The injection device uses irrigation water as the working (driving) fluid; this water is taken from the same pipeline in which the primary solution (that in a mixture with the irrigation water forms the fertilizing solution) is injected, which provides autonomy in operation of the fertigation equipment in any spot of the irrigation enclosure. The overpressure needed to perform injection is achieved on the principle of difference between the active surfaces of driving chambers and injection chambers. The injector shall be installed in bypass against the pipeline which supplies the drip or micro sprinklers irrigation plant, with which it forms a working assembly. The pump working pressure is 2.5...3 bar, and it is limited to such values by the pressure allowable in the irrigation water distribution network. Laboratory tests have highlighted that for the previously defined pressure range, at flow rates of the irrigation plant of 10.5...13.5 l/min, the device achieves injection flow rates of 2.5...3 l/min, at frequencies of the mobile assembly of 90...110 double strokes/min. Tests on the fertigation equipment, in real operating conditions, will be conducted at the premises of project partners USAMV Iasi and ICDP Pitesti Maracineni.

Key words: Injection device, fertigation, primary solution, hydraulic control

Irrigation techniques have continually evolved towards reducing water consumption at plants (dripping, micro-sprinkling) and a higher capitalization of water by mitigating losses and pairing with other works (fertilizing, herbiciding, etc). (Șovăială Gh. *et al*, 2015)

A modern agriculture cannot be conceived without irrigation, which is both a high performance technological sequence in agro technology of crops and the most important technical means of eliminating the water deficit in soil, thus representing the infrastructure for sustainable development. The fertigation equipment, intended for fertigation of horticultural crops in protected areas (vegetables and flowers), and respectively for fertigation of horticultural crops in open field (vegetables, trees and fruit shrubs), includes the device which injects the primary solution into the irrigation water, the container for the preparation of the former, devices for measurement and control of operating parameters, hydraulic connection elements between items of equipment. This equipment enables coupling the technical elements of

irrigation with the technical elements of fertigation, so that at the end of watering, when there is reached the depth of water penetration in the zone of prevailing development of plant roots, there is administered the entire amount of fertilizing solution necessary to plants, determined according to the state of plant growth.

The injector is connected in parallel (by-pass system) to the main circuit of the irrigation facility, by two quick couplers, in order to take over the water used as a driving fluid, and respectively in order to inject the primary solution; this assembling system does not introduce hydraulic pressure loss in the pipe of the irrigation facility.

MATERIAL AND METHOD

The injector, which is the main component of the fertigation equipment, is intended to introduce the primary solution into the supply pipeline of the irrigation facility that it serves. The mixture of primary solution and irrigation water forms the fertilizing solution, which reach plants via the distribution network and devices.

¹ INOE 2000-IHP, Bucharest

² "Ion Ionescu de la Brad" University of Agricultural Sciences and Veterinary Medicine, Iasi

The injection device, type double diaphragm pump (Avram M., 2005), hydraulically driven, uses as a working fluid the irrigation water taken from the same pipeline in which primary solution is injected, which provides autonomy in operation in any spot of the irrigation enclosure. Injection pressure is achieved on the principle of difference between the active surfaces of driving chambers and injection chambers, and it can be determined accurately, according to the hydraulic parameters of the irrigation facility with which it forms a working assembly, early since the equipment design stage. Flow of injected primary solution can be adjusted within a wide range, by adjusting the flow which supplies the driving chambers, and respectively by throttling the flow which supplies the control chambers of the hydraulic directional valve, thus altering frequency of the piston, which is joined with the membranes that separate driving chambers from injection chambers.

The injector (figures 1...3) has compact design; in its body 1 there are mounted the mobile assembly, the hydraulic directional valve, the primary solution intake/discharge valve assembly, the throttles of control chambers of hydraulic directional valve, and the piston which controls the spool of hydraulic directional valve.

The mobile assembly consists of piston 2, membranes 3, outer flanges 4 and inner flanges 5, special screws 6 for fastening the membranes to the piston.

The hydraulic directional valve, spool fitted, 7 is a 2-position / 4-port valve.

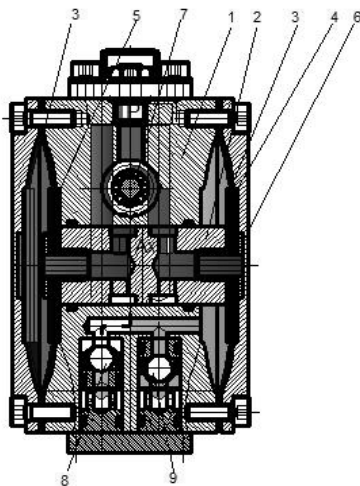

Figure 1 E-E section through the injection device
1-body; 2-piston; 3-membranes; 4-outer flanges;
5-inner flanges; 6-screws fastening the membranes;
7-hydraulic directional valve, spool fitted; 8-primary
solution intake valve; 9-primary solution discharge
valve

The primary solution intake/discharge valve assembly – each injection chamber is connected to an intake valve-8 and a discharge valve-9. The intake/discharge valves of the two injection chambers are interconnected and also connected to the primary solution intake nozzles *As*, and respectively connected to the primary solution discharge nozzles *Re* (figure 3).

The piston which controls the spool of hydraulic directional valve-10 is shown in figure 2.

The driving chambers are bounded by the outer surfaces of the membranes and the caps 11, while the injection chambers are bounded by the inner surfaces of the membranes and the body.

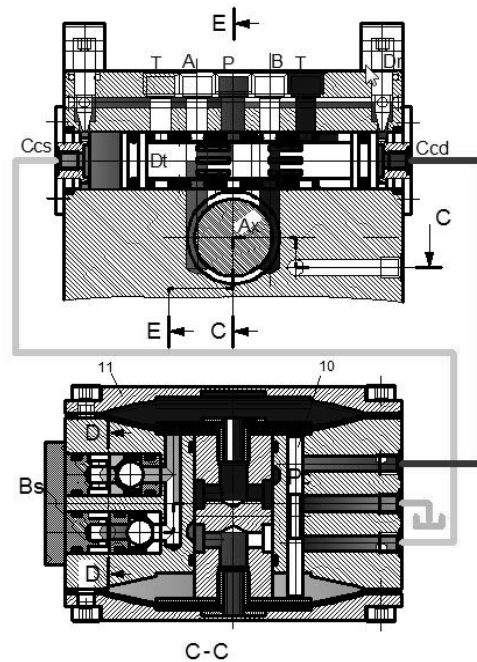

Figure 2 C-C section through the injection device
10-piston controlling the spool of hydraulic
directional valve; 11-caps

Principle of operation

Depending on the position occupied by the spool of hydraulic directional valve, the port P is connected either to the port A or the port B, from which, via interior channels in the body and piston, the driving chambers are supplied with pressurized water. On the outside, ports A and B are sealed with plugs.

Through the ports T the fluid from the driving chambers is alternately discharged (A to T or B to T), in the phase of retraction of the membrane assembly (decrease in capacity of the driving chambers).

The water discharged from the driving chambers is distributed to the plants through a distribution pipe with embedded drippers.

Also from the port P the control chambers *Ccs-Ccd* of hydraulic directional valve are continuously supplied with pressurized water. The mobile assembly alternatively moves, by means of the inner flanges, the control piston, which shortly before reaching the stroke end connects one of the control chambers to the atmosphere, causing spool valve switch from the control chamber which is pressurized to the chamber which is depressurized. The throttles *Dr* maintain a position of equilibrium for the directional valve.

Supplying the left driving chamber with pressurized water causes the mobile assembly to move to the right, resulting in:

-discharge of driving fluid from the right driving chamber;

-intake of primary solution in the right injection chamber;

-injection of primary solution from the left injection chamber.

Decreasing the capacity of the left injection chamber (implicitly increasing the pressure), causes placing the intake valve ball on seat and rising the discharge valve ball from seat. Increasing the capacity of the right injection chamber (implicitly generating depressure) causes rising the intake valve ball from seat and placing the discharge valve ball on seat. The injection chambers are alternately connected to the joint intake couplings (on the tank with primary solution), respectively discharge couplings (in the supply pipeline of the irrigation facility) (figure 3).

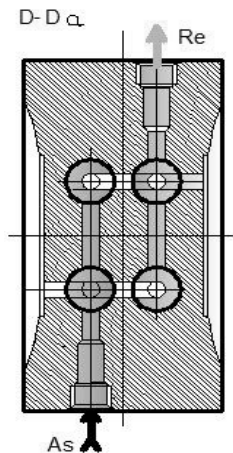

Figure 3 Connections between primary solution intake/discharge valves

Injection device parameters

If the injection device is type positive displacement pump, to calculate the pump flow q one needs to know the volume V_s of primary solution injected per stroke and pump frequency f . (Biolan I. et al, 2010), As the volume V_s of primary solution injected per stroke is a value imposed through design, pump frequency is calculated as:

$$f = \frac{n [\text{strokes}]}{t [\text{min}]}, \text{ where}$$

n - no. of strokes made;

t – time required for performing the strokes.

Flow of injector is calculated as:

$$q [l/h] = 60 \times f [\text{strokes / min}] \times V_s$$

Note. In simple action pumps, stroke means moving in both directions, while in double action pumps stroke means moving in only one direction.

The injection equipment introduces the primary solution (of concentration C_m) in the irrigation water existing inside the irrigation facility, in order to produce the final solution (the fertilizing solution of concentration C_s). The equation for primary solution concentration is:

$$C_m [g/l] = \frac{M}{V}, \text{ where:}$$

M - mass of chemical fertilizers, expressed in grams;

V - volume of water in which fertilizers were dissolved, expressed in (l); this volume must be greater than the water volume in which chemical fertilizers reach saturation.

If chemical fertilizer is purchased in liquid form, primary solution concentration C_m is expressed as percentage (%) and it is made by the producer. The same goes for fertilizing solution concentration C_s ; it is also expressed as percentage (%), and the injection dosage as well. For the case of drip irrigation there is recommended a fertilizing solution concentration C_s of less than 4 g/l to not clog the drippers:

$$C_s \leq 4 \text{ g/l}$$

When calculating time of making fertigation T_f , there are two possible situations.

In the case of using soluble solid fertilizers, in which the primary solution is prepared by the person who makes irrigation, time T_f is calculated by using the equation:

$$T_f [\text{min}] = \frac{60 \times M [\text{g}]}{Q [\frac{1}{h}] \times C_s [\frac{g}{l}]}$$

If there are used liquid fertilizers (which represent the primary solution), time T_f is calculated by using the equation:

$$T_f [\text{min}] = \frac{60 \times M [\text{g}]}{Q [\frac{1}{h}] \times C_s [\%]}$$

This mentioned time T_f must be less than or equal to the time of making irrigation T , to ensure environmental protection.

If the irrigation facility makes fertigation while operating, then fertigation time is equal to irrigation time:

$T_f = T$, where:

T - irrigation time, [min];

T_f - fertigation time, [min].

Final solution concentration is calculated as:

$$C_s [g/l] = \frac{60 \times M [\text{g}]}{T [\text{min}] \times Q [\frac{1}{h}]}$$

$$\text{or } C_s = \frac{60 \times V [l]}{T [\text{min}] \times Q [\frac{1}{h}]}$$

If there are used soluble fertilizers and one knows the concentration of fertilizing solution and the flow of injection equipment (and implicitly the injection dosage), primary solution concentration is calculated by use of equation:

$$C_m [g/l] = \frac{C_s [\frac{g}{l}]}{r [\%]}$$

From equations: $q [l/h] = 60 \times f [\text{strokes / min}] \times V_s$

$$\text{and } C_s = \frac{60 \times V [l]}{T [\text{min}] \times Q [\frac{1}{h}]}, \text{ it results:}$$

$$V_{[I]} = \frac{M[g] \times r[\%]}{C_s \left[\frac{g}{l} \right]} \text{ or } V_{[I]} = \frac{M[g]}{C_m \left[\frac{g}{l} \right]}$$

RESULTS AND DISCUSSIONS

Tests on the injection device in laboratory conditions aimed to demonstrate injector functionality and to determine the main technical and functional parameters. These tests have been conducted with the help of the hydraulic equipment tests stand which uses pressurized water as the working fluid, with collaboration of project partners; the aforementioned tests stand is part of the infrastructure existing in the Laboratory of Environmental Protection of INOE 2000-IHP Bucharest.



Figure 4 The hydraulic equipment tests stand using pressurized water as the working fluid

The pumping block on this stand, type WILO ECONOMY CO-2 MHI 206/ER-RBI-CALOR, consists of two high pressure horizontal centrifugal pumps, with no self-priming, stainless steel, connected in parallel, of flow Q_{max} 10 m³/h and pump head H_{max} 67 mWC.

Preliminary results of laboratory tests are presented in *table 1*.

Table 1

Technical and functional parameters of injector

p (bar)	f (ds/min)	Q_{inst} (l/h)	Q_{inst} (l/min)	q_{inj} (l/min)	r (%)	Ra-hid (%)
2.0	70	384	6.4	2.2	0.19	45.8
2.5	94	624	10.5	2.8	0.29	46.6
3.0	112	798	13.2	3.4	0.42	48.5
3.5	120	960	16.0	3.5	0.56	43.7
4.0	170	1140	19.0	4.1	1.06	44.5
4.5	192	1200	20.0	4.5	0.36	44.0

p- water pressure in the irrigation facility, bar;
f- frequency of pump mobile assembly, double strokes/min;

Q_{inst} - flow of the irrigation facility, l/h; l/min;

q_{inj} - flow injected by pump, l/min;

r- injection rate- concentration of fertilizer in the irrigation water, (%);

Ra-hid- hydraulic efficiency, (%).

The minimum pressure at which the pump starts running is 0.5 bar, and maximum working pressure is 6 bar.

Pump hydraulic efficiency, seen as the ratio of fertilizing solution injected flow v_{inj} and water volume consumed for the operation of the

pump v_m , $\frac{v_{inj}}{v_m} \cdot 100$, (%), is determined by the

hydraulic parameters of water in the driving chambers and the fertilizing solution concentration.

Pressure up to which the pump operates at high efficiency is 3.0 bar, hydraulic efficiency being 48.5 %, consistent with hydraulic efficiency of dosing pumps existing on the global scale.

CONCLUSIONS

Preliminary laboratory tests highlighted injector functionality and achievement of the main technical and functional parameters in accordance with the ones forecast in the design phase.

Following completion of laboratory tests, which will be conducted in accordance with the testing methodology drafted in Phase 2 of the project no. 158/2014, we will proceed to conducting tests in real operating conditions at the headquarters of project partners ICDP Pitesti Maracineni- for fertigation, by using drip irrigation equipment and micro sprinklers, of intensive crops of apple, blueberry and strawberry, and respectively USAMV Iasi- for drip fertigation of horticultural crops in protected areas.

ACKNOWLEDGMENTS

Research presented in this paper has been developed with financial support of UEFISCDI (Executive Unit for Financing Higher Education, Research, Development and Innovation) under PCCA 2013 Programme, Financial Agreement no. 158/2014.

REFERENCES

- Avram M., 2005 - *Actionari hidraulice si pneumatice, echipamente si sisteme clasice si mecatronice / Hydraulic and pneumatic drives, classic and mechatronic equipment and systems*, ISBN 973-7787-40-4.
- Biolan I., Serbu I., Șovăială Gh., Mardare F., 2010 - *Tehnici si tehnologii de fertirigare a culturilor agricole / Techniques and technologies for fertigation of agricultural crops*. AGIR (eds.), ISBN: 978-973-720-344-1.
- Șovăială Gh., Anghel S., Țenu I., Tănăsescu N., 2015 - *Research on the development of innovative fertigation equipment*. In: Proc. of 23rd International Scientific and Technical Conference CYLINDER 2015 - Testing, Designing, Manufacturing and Operation of Hydraulic Systems, September 23-25, Kliczków Castle, Poland, 163-172, ISBN 978-83-60708-88-0.