

Phase noise and jitter modeling for fractional-N PLLs

S. A. Osmany, F. Herzel, K. Schmalz, and W. Winkler

IHP Im Technologiepark 25, 15236 Frankfurt (Oder), Germany

Abstract. We present an analytical phase noise model for fractional-N phase-locked loops (PLL) with emphasis on integrated RF synthesizers in the GHz range. The noise of the crystal reference, the voltage-controlled oscillator (VCO), the loop filter, the charge pump, and the sigma-delta modulator (SDM) is filtered by the PLL operation. We express the rms phase error (jitter) in terms of phase noise of the reference, the VCO phase noise and the third-order loop filter parameters. In addition, we consider OFDM systems, where the PLL phase noise is reduced by digital signal processing after down-conversion of the RF signal to baseband. The rms phase error is discussed as a function of the loop parameters. Our model drastically simplifies the noise optimization of the PLL loop dynamics.

1 Introduction

Frequency synthesizers are essential components in wireless RF transceivers. A synthesizer provides a stable signal for frequency conversion, modulation and demodulation. A fractional-N PLL gives a greater flexibility than an integer-N PLL due to the higher frequency resolution (Perrot et al., 2002). The phase noise is the most important performance criterion of the synthesizer for its stringent requirement in many applications, e.g., in OFDM based systems (Stott, 1998; Herzel et al., 2005). The problem with phase noise is exacerbated in high-frequency applications, since the oscillator phase noise at a given frequency offset typically increases in proportion to the carrier frequency. For this reason, the minimization of the phase noise in frequency synthesizers is of special interest in mm-wave application, e.g., in the 60 GHz band (Winkler et al., 2005). Many publications on phase noise modeling of oscillators and PLLs have

appeared during the last few years, e.g. Lee and Hajimiri (2000)–Rohde (2005). This paper is focussed on problems which are specific to integrated PLLs. They arise mainly from the low quality factor of the available passives as well as from the limited size of filter capacitors. Especially, the low quality factor of integrated inductances causes a high noise level of the voltage-controlled oscillator (VCO). This problem is exacerbated by the fact that variations of the device parameters with process and temperature require a relatively large VCO tuning range affecting oscillator noise and loop filter noise. In integrated PLLs, the values of the integrated capacitances are limited by chip area and, possibly, yield. This can make the filter noise comparable to the VCO noise, if the VCO gain is large. Another problem arises in RF synthesizers for mm-wave applications. The high oscillation frequency results in a large division factor enhancing the reference noise to a level comparable to the phase noise of integrated VCOs. The different dependencies of the noise contribution on the PLL dynamics results in a subtle trade-off for the loop bandwidth.

This paper describes the phase noise spectrum of a PLL, where emphasis is placed on the high-pass filtering in OFDM systems due to the correction of the common phase error.

2 PLL phase noise sources

In the literature, two types of phase noise are used, the two-sided power spectral density (PSD) of the phase and the single-sideband phase noise. For moderate and large frequency offsets, these quantities are almost equal (Herzel, 2004). For wideband systems, close-in phase noise is less relevant due to a large channel width and/or proper baseband filtering explained below. Therefore, we will not distinguish between the single-sideband phase noise and the two-sided power spectral density of the phase in the remainder of this paper. The phase noise S can be determined from the single-

Correspondence to: S. A. Osmany
(osmany@ihp-microelectronics.com)

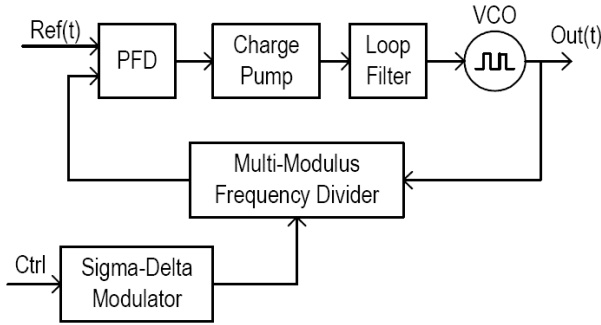

Fig. 1. Schematic view of a fractional-N synthesizer architecture.

sideband phase noise \mathcal{L} specified in units of dBc/Hz according to

$$S = 10^{\mathcal{L}/10}. \quad (1)$$

In a charge-pump PLL as used in modern communication systems, the output phase of the VCO is divided by N and compared with a reference phase in a phase-frequency detector (PFD). A charge pump current proportional to the phase error is produced, low-pass filtered, and applied to the control input of the VCO as shown in Fig. 1. In fractional-N PLLs the divider ratio is controlled by a sigma-delta modulator (SDM).

The output voltage of a PLL can be described as

$$V_{\text{out}}(t) = V_0 \cos[\omega_0 t + \phi_{\text{out}}(t)], \quad (2)$$

where V_0 is the amplitude, $f_0 = \omega_0/(2\pi)$ is the oscillation frequency, and $\phi_{\text{out}}(t)$ is the excess phase. The dominating noise sources in our type of PLL are the VCO and the reference. But also the low-pass filter (LPF) and charge pump (CP), if not properly designed, may significantly contribute to the overall phase noise. The problem is critical for integrated PLLs due to the relatively small capacitances and the large VCO gain. In fractional-N PLLs, another important noise source may significantly contribute to the overall phase noise, namely, quantization noise of the $\Sigma - \Delta$ modulator. In this paper, we will include the following five noise sources:

- reference noise,
- VCO noise,
- loop filter noise,
- charge pump noise,
- $\Sigma - \Delta$ quantization noise.

These are typically the dominant noise contributions in integrated fractional-N RF synthesizers for the GHz range (Uang, 2004; Valero-Lopez, 2004). Digital noise is disregarded in this paper.

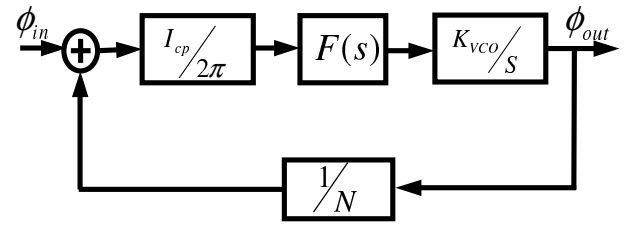

Fig. 2. Linearized PLL model.

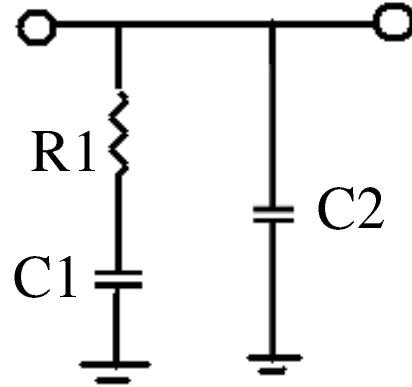

Fig. 3. 2nd order loop filter.

3 Linearized PLL model

Fig. 2 shows the linearized model of a PLL, where the PFD/CP gain is modeled by $I_{CP}/2\pi$ [A/rad], the loop filter transimpedance is denoted as $F(s)$, and the VCO gain is K_{VCO}/s . N is the divider ratio of the PLL. Note that the VCO gain $K_{VCO} = d\omega/dV_{ctrl}$ refers to the angular frequency and is given in units of rad/s/V. The closed-loop transfer function reads

$$H = \frac{H_0}{1 + H_0/N}, \quad (3)$$

where the forward path transfer function H_0 is

$$H_0 = \frac{I_{CP} F(s) K_{VCO}}{2\pi s}. \quad (4)$$

For the filter transimpedance calculation we assume that no current flows into VCO control input, since the filter capacitances are notably large. For the second-order filter according to Fig. 3, we obtain the transimpedance

$$F(s) = \left(R_1 + \frac{1}{sC_1} \right) \parallel \frac{1}{sC_2}. \quad (5)$$

In order to suppress reference spurs, an additional low-pass filter is often included as shown in Fig. 4, resulting in a third-order loop filter. The current through Z_2 causes a voltage

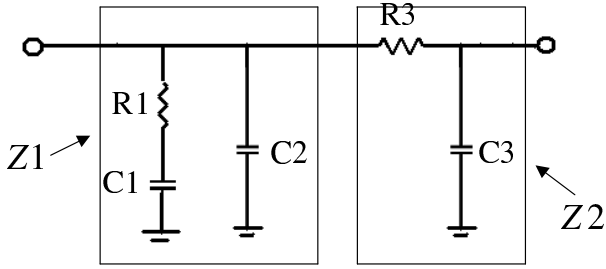

Fig. 4. 3rd order loop filter.

drop over C_3 , which can be calculated by using the current divider rule resulting in

$$F(s) = \frac{1}{sC_3} \frac{1/Z_2}{1/Z_1 + 1/Z_2}, \quad (6)$$

where

$$Z_1 = \left(R_1 + \frac{1}{sC_1} \right) \parallel \frac{1}{sC_2} \quad (7)$$

and

$$Z_2 = R_3 + \frac{1}{sC_3}. \quad (8)$$

The crossover frequency of the open loop transfer function is the PLL bandwidth f_T , defined by

$$\text{mag} \left(\frac{H_0(f_T)}{N} \right) = 1. \quad (9)$$

The PLL phase margin is given by

$$\text{phase margin} = \text{phase} \left(\frac{H_0(f_T)}{N} \right) + 180^\circ. \quad (10)$$

In the following five sections, the noise sources mentioned in Sect. 2 will be analytically described in the framework of the linear PLL model. The transfer functions of the noise sources to the PLL output will be calculated.

4 Reference noise

A low-noise reference is crucial for a good PLL performance. The phase noise contribution of the reference oscillator as a function of the frequency offset f is modeled by

$$S_{REF}(f) = S_{REF}(\Delta f) \frac{(\Delta f)^2}{f^2} + S_{REF, \text{floor}}, \quad (11)$$

where $S_{REF}(\Delta f)$ is the phase noise at a specific offset Δf in the -20 dB/decade region of the spectrum and $S_{REF, \text{floor}}$ is the noise floor of the reference. According to Fig. 5, the transfer

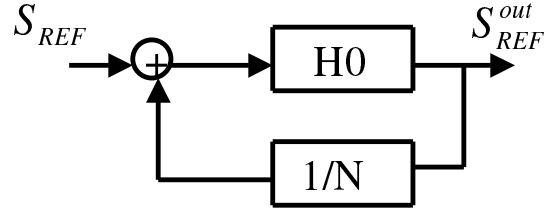

Fig. 5. Reference noise shaping model.

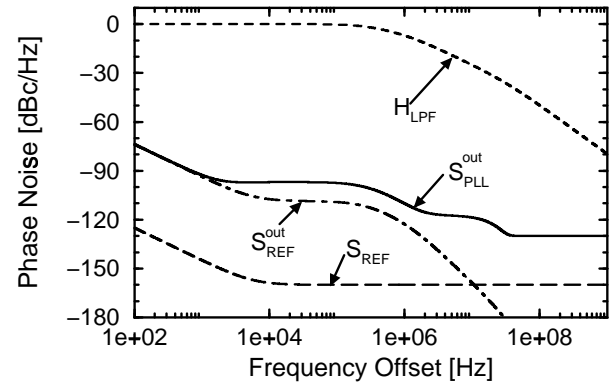

Fig. 6. Reference noise at the PLL input and output. In addition, the solid line shows the total output noise spectrum.

function from the reference phase to the synthesizer output phase is given by

$$\frac{\phi_{REF}^{out}}{\phi_{REF}} = \frac{H_0}{1 + H_0/N}. \quad (12)$$

From this, we obtain the reference noise spectrum at the output from the reference noise spectrum at the input according to

$$S_{REF}^{out} = S_{REF} N^2 |H_{LPF}|^2 \quad (13)$$

with the low-pass filter function

$$H_{LPF} = \frac{H_0/N}{1 + H_0/N}. \quad (14)$$

Note that the reference noise is low-pass filtered and amplified by the divider ratio. Although the phase noise of the reference is typically lower than that of the VCO by many orders of magnitude, it may become comparable to the VCO noise, if a large division factor is employed. For instance, the value of $N=1024$ in Winkler et al. (2005) corresponds to an increase of the phase noise by about 60 dB as it appears at the PLL output. Figure 6 shows the reference noise for typical crystal oscillators (long dashed). Using the noise transfer function (dashed) we obtain the corresponding phase noise contribution (dot-dashed). Comparison with the total phase noise (solid) shows that at offsets below 1 kHz the reference noise dominates.

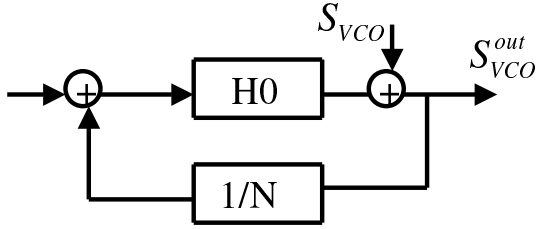

Fig. 7. VCO noise shaping model.

5 VCO noise

Oscillator phase noise has been the subject of numerous papers. The optimization of the VCO phase noise is beyond the scope of this paper. For low-noise microwave oscillator design we refer to the extensive literature cited, e.g., in Rohde (2005). The phase noise of a free running oscillator is modeled by

$$S_{VCO}(f) = S_{VCO}(\Delta f) \frac{(\Delta f)^2}{f^2} + S_{VCO, \text{floor}}, \quad (15)$$

where $S_{VCO}(\Delta f)$ is the phase noise at a specific offset Δf in the -20 dB/decade region of the spectrum, typically at 1 MHz. $S_{VCO, \text{floor}}$ is the noise floor of the VCO. Note that we have disregarded flicker noise, since we focus on applications, where the loop bandwidth is larger than the $1/f^3$ noise corner frequency of the VCO, which is on the order of 10 kHz for modern SiGe HBT technologies (Niu, 2005). Flicker noise in the VCO is then effectively suppressed due to the high-pass filtering by the PLL. According to Fig. 7, the transfer function from the VCO output phase to the PLL output reads

$$\frac{\phi_{VCO}^{\text{out}}}{\phi_{VCO}} = \frac{1}{1 + H_0/N}. \quad (16)$$

Consequently, the PLL output noise to due VCO phase noise is given by

$$S_{VCO}^{\text{out}} = S_{VCO} |1 - H_{L\text{PF}}|^2 \quad (17)$$

with the low-pass filter Function (14). Note that the VCO noise is high-pass filtered in the PLL. Figure 8 shows the VCO phase noise (dashed) and its contribution to the PLL output phase noise (long-dashed). The PLL noise spectrum at higher offset is dominated by the VCO phase noise.

6 Loop filter noise

We model the noisy loop filter by a noise current in parallel with a noise-less admittance as shown in Fig. 9. The two-sided power spectral density of noise current i_n can be expressed as

$$S_{\text{FIL}}(s) = 2k_B T \text{Re}(Y_{\text{FIL}}(s)), \quad (18)$$

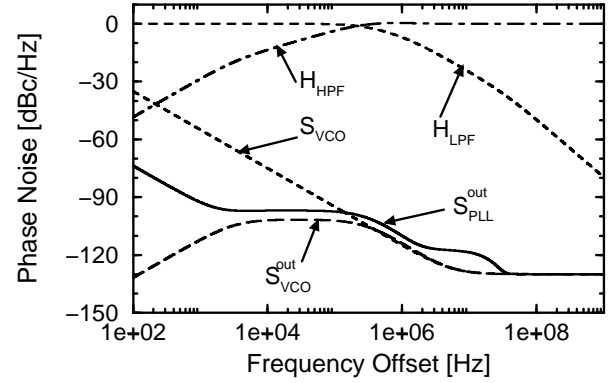

Fig. 8. VCO noise for open-loop (dashed) and closed-loop (long-dashed) case. In addition, the solid line shows the total output noise spectrum.

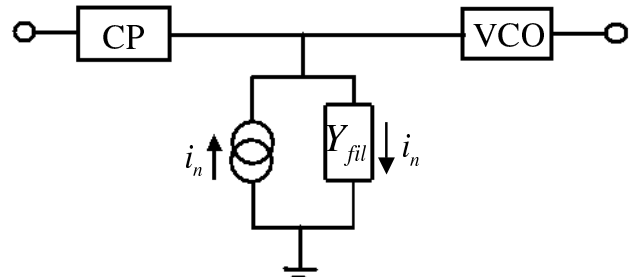

Fig. 9. Filter noise model.

where k_B is Boltzmann's constant, T the absolute temperature, and Y_{FIL} is the complex admittance of the filter from the charge pump output to ground. Equation (18) is the well-known Nyquist equation, generalized to a passive two-pole described by a complex admittance. For a second-order loop filter $Y_{\text{FIL}}(s)$ equals the inverse transimpedance $1/F(s)$, but for a third-order filter this is no longer the case. We find for this case $Y_{\text{FIL}}(s) = 1/Z_1 + 1/Z_2$, where Z_1 and Z_2 are given by (7) and (8). We assume $|Z_{\text{FIL}}| \ll Z_{\text{out}}^{\text{CP}}$ and $|Z_{\text{FIL}}| \ll Z_{\text{in}}^{\text{VCO}}$. This implies that the total filter noise current flows through the filter impedance. Using the filter transimpedance (6), we obtain a noise voltage PSD at the VCO input. Exploiting the VCO phase noise transfer function, we obtain the noise spectrum at the output given by

$$S_{\text{FIL}}^{\text{out}}(s) = S_{\text{FIL}}(s) |F(s)|^2 \left| \frac{K_{VCO}}{s} \right|^2 |1 - H_{L\text{PF}}|^2. \quad (19)$$

Note that the noise transfer function for the loop filter has a band-pass characteristics. Figure 10 shows the filter contribution for the integrated PLL. In the region around the PLL bandwidth, the filter noise may significantly contribute to the overall phase noise due to the small filter capacitances. Its contribution can be much reduced by adding an external

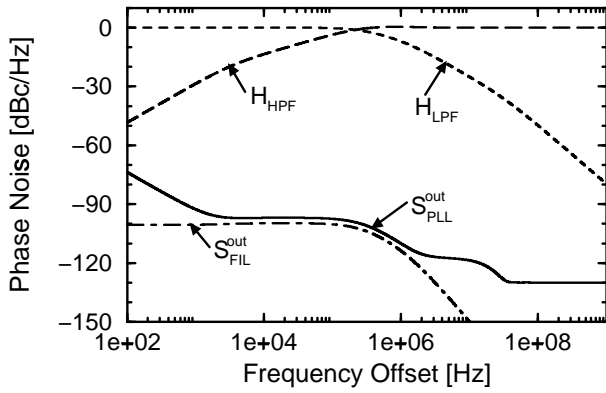

Fig. 10. Filter noise at the PLL output. In addition, the solid line shows the total output noise spectrum.

capacitor which is, however, not always desirable for low-cost integrated solutions.

7 Charge pump noise

For a PLL to work at a given bandwidth, a large charge pump current is generally favorable in order to reduce the loop filter resistance R . The large current, however, produces significant current noise during the time, where the charge pump is active. The time between two phase comparison instants is referred to as $t_{comp} = 1/f_{comp}$, where f_{comp} is the comparison frequency at the PFD input. In order to prevent a dead zone, the charge pump currents are usually activated during a time t_{CP} , which is in the order of 100 ps to 1 ns in the steady state for an integer-N PLL. For a fractional-N PLL the activation time is typically larger due to the momentary frequency error inherent in this type of PLL (Perrot et al., 2002). In a typical CMOS charge pump as shown in Fig. 11, an N-MOSFET and a P-MOSFET are connected to the filter. Their thermal and flicker noise is transferred to the PLL output causing phase noise. We write the drain current noise PSD of a MOSFET as described in Allen (1987):

$$S_i^{MOS} = \gamma 4k_B T g_m + \frac{(KF)I_D}{f C_{OX} L^2}, \quad (20)$$

where $\gamma = 2/3$ for long-channel devices. Adding the noise contributions of the two transistors, we obtain

$$S_{CP} = \left[S_i^{NMOS} + S_i^{PMOS} \right] \alpha, \quad (21)$$

where $\alpha = t_{CP}/t_{comp}$ is the duty cycle of the charge pump, that is, the ratio of the average charge pump activation time and the time difference between two comparison instants. Note that the spectral densities S_i^{NMOS} , S_i^{PMOS} must be averaged, since g_m varies with time. The noise currents produce a noise voltage over the filter impedance, which is transferred to the

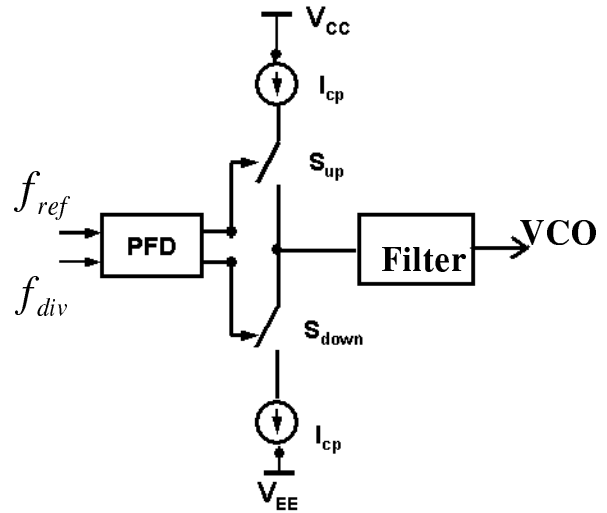

Fig. 11. Charge pump noise model.

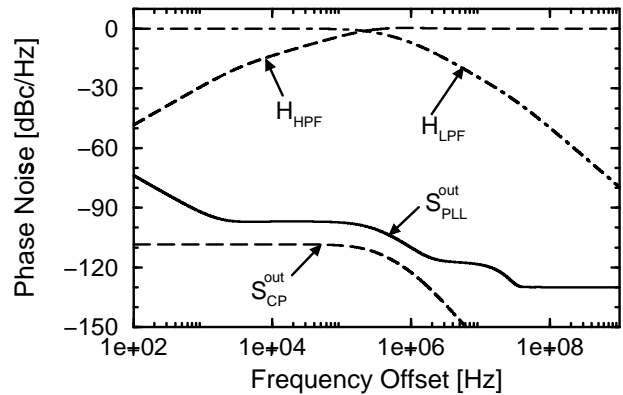

Fig. 12. Charge pump noise at the PLL output. In addition, the solid line shows the total output noise spectrum.

PLL output phase according to the VCO noise transfer function. As a result, we obtain the noise spectrum at the PLL output

$$S_{CP}^{out} = S_{CP} |F(s)|^2 \left| \frac{K_{VCO}}{s} \right|^2 |1 - H_{LPF}|^2. \quad (22)$$

Figure 12 shows the contribution of the charge pump to the total PLL phase noise. Flicker noise contribution is disregarded here. The PLL bandwidth is proportional to the product of the charge pump current I_{CP} and the filter resistance R_1 . Consequently, if a certain PLL bandwidth is required, the charge pump current noise must be carefully traded off with the noise produced by the filter resistance R_1 .

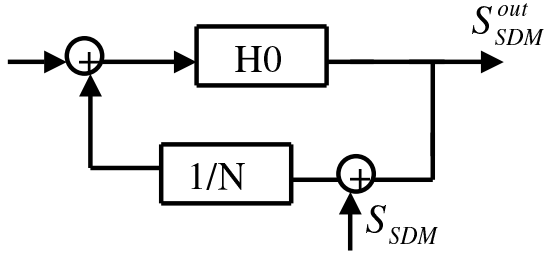

Fig. 13. SDM noise shaping model.

8 Sigma-delta quantization noise

In a fractional-N synthesizer, the integer divider value is dithered dynamically to achieve fractional values. A classical fractional-N architecture uses an accumulator to perform the dithering operation. But in this case, a periodic error signal creates spurious tones in the synthesizer output. A better approach is to use a sigma-delta modulator rather than a single accumulator to perform the dithering operation. This results in a much better spurious performance. But the sigma-delta modulator adds quantization noise. For the PLL noise analysis, we model the SDM by a divider value and a sigma-delta noise spectrum as shown in Fig. 13. The quantization noise spectrum for a m -th order MASH type sigma-delta modulator is given by Miller (1991),

$$S_{SDM} = \frac{(2\pi)^2}{12f_{REF}} \left[2 \sin \left(\frac{\pi f}{f_{REF}} \right) \right]^{2(m-1)}, \quad (23)$$

where m is the order of the modulator and f_{REF} is the reference frequency. The transfer function for the noisy phase from the SDM output to the PLL output reads

$$\frac{\phi_{SDM}^{out}}{\phi_{SDM}} = \frac{H_0/N}{1 + H_0/N}. \quad (24)$$

Consequently, we obtain the SDM noise spectrum at the PLL output

$$S_{SDM}^{out} = S_{SDM} |H_{LPF}|^2. \quad (25)$$

Note that the SDM quantization noise spectrum is low-pass filtered in the PLL. Figure 14 shows the resulting phase noise contribution.

9 PLL phase noise spectrum and jitter

In a PLL the phase noise of the reference is low-pass filtered, while the VCO noise is high-pass filtered and the filter noise is bandpass-filtered. The charge pump noise and sigma delta quantization noise is low-pass filtered in the PLL. This results in the total phase error

$$\phi_{out}(t) = N \int_0^\infty dt' h_{LPF}(t') \phi_{REF}(t-t') +$$

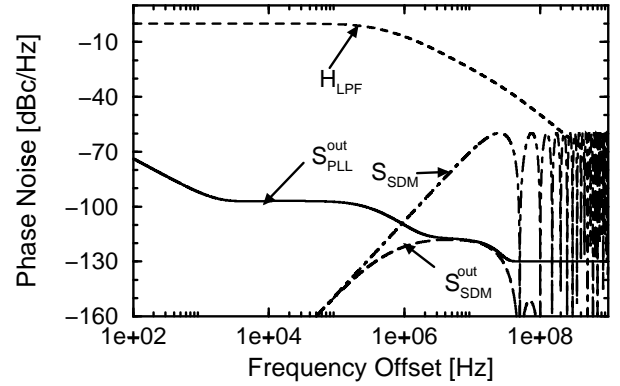

Fig. 14. SDM noise at divider input and at PLL output. In addition, the solid line shows the total output noise spectrum.

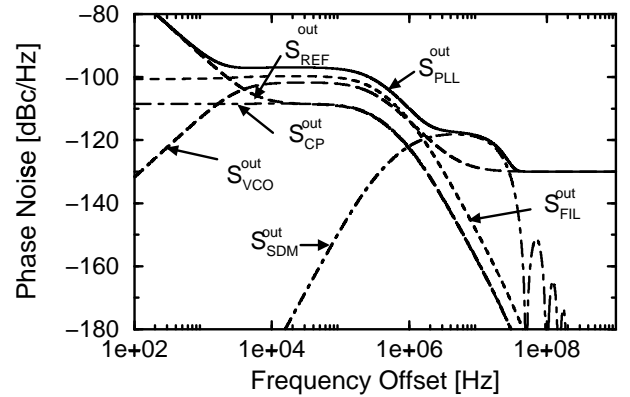

Fig. 15. Phase noise spectrum and its contributors.

$$\int_0^\infty dt' h_{HPF}(t') \phi_{VCO}(t-t') + \int_0^\infty dt' h_{BPF}(t') i_{LPF}(t-t') + \int_0^\infty dt' \tilde{h}_{LPF}(t') i_{CP}(t-t') + \int_0^\infty dt' \hat{h}_{LPF}(t') \phi_{SDM}(t-t'), \quad (26)$$

where $N h_{LPF}$, h_{HPF} , h_{BPF} , \tilde{h}_{LPF} and \hat{h}_{LPF} are the linear phase responses at the PLL output referred to the phase noise source. Note that $N h_{LPF}(t')$ implies a multiplication by the division ratio N , which enhances the reference noise.

Since the five noise sources are uncorrelated, the corresponding noise spectra must be added to obtain the overall phase noise spectrum

$$S_{PLL}^{out}(f) = S_{REF}^{out}(f) + S_{VCO}^{out}(f) + S_{FIL}^{out}(f) + S_{CP}^{out}(f) + S_{SDM}^{out}(f), \quad (27)$$

where f is the frequency offset from the carrier and $S_{REF}^{out}(f)$, $S_{VCO}^{out}(f)$, $S_{LPF}^{out}(f)$, $S_{CP}^{out}(f)$ and $S_{SDM}^{out}(f)$ are the phase noise

contributions of the five previously discussed noise sources referred to the PLL output. The rms phase error, sometimes called absolute phase jitter, is given by

$$\sigma_{\phi}[\text{degree}] = \frac{180^{\circ}}{\pi} \sqrt{\int_0^{\infty} 2 S_{\text{PLL}}^{\text{out}} df}. \quad (28)$$

In the high-speed digital design community, the so-called absolute jitter is a common measure to quantify the timing error of a PLL driven by a clean reference. It is given by

$$\sigma_{\text{abs}} = \frac{\bar{T}}{360^{\circ}} \sigma_{\phi}, \quad (29)$$

where $\bar{T}=1/f_0$ is the average oscillation period. The jitter can be calculated numerically using our analytic expression for the phase noise. This allows a fast optimization of the loop parameters for a low jitter.

10 Modeling of RF synthesizers for OFDM

A low pll jitter is especially important for OFDM systems, where phase noise may easily destroy the orthogonality of the different subcarriers. A strong correlation between the rms phase error and the bit-error rate of an OFDM system has been demonstrated in Herzel et al. (2005). In OFDM systems, different signals are used at frequencies separated in frequency by the sub-carrier spacing $\Delta f_{\text{carrier}}$. The inverse of that

$$T_u = 1/(\Delta f_{\text{carrier}}) \quad (30)$$

is called the useful symbol time. In state-of-the-art baseband processor implementations part of the phase noise (common phase error) can be eliminated after the signal has been down-converted to baseband. This process can be modelled by a high-pass filter according to Stott (1998)

$$H_{\text{OFDM}}(f) = 1 - \text{sinc}^2(fT_u), \quad (31)$$

where the sinc function is defined by $\text{sinc}(x)=\sin(\pi x)/(\pi x)$. The resulting improved phase noise spectrum reads

$$S_{\text{OFDM,eff}}(f) = S_{\text{PLL}}^{\text{out}}(f)|1 - \text{sinc}^2(fT_u)|. \quad (32)$$

Integrating this spectrum, we obtain the rms phase error given by Stott (1998), Herzel et al. (2005)

$$\sigma_{\phi}[\text{degree}] = \frac{180^{\circ}}{\pi} \sqrt{2 \int_0^{B/2} df S_{\text{OFDM,eff}}(f)}. \quad (33)$$

The upper integration limit is half the bandwidth of the whole OFDM band. This corresponds to the middle-carrier weighting function as representative for the whole OFDM signal. Equation (33) allows the effective phase error σ_{ϕ} to be calculated from circuit parameters and carrier spacing $(\Delta f)_{\text{car}}=1/T_u$. The result is shown in Fig. 16.

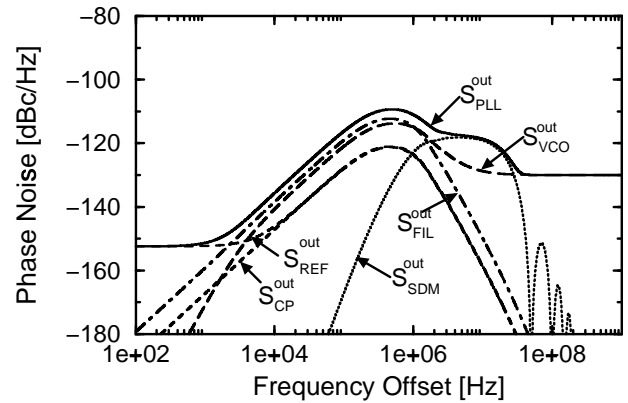

Fig. 16. Phase noise spectrum after OFDM filtering.

11 Conclusions

We have presented analytical expressions for the phase noise spectrum of phase-locked loops. We have included white noise of the reference, the VCO, the loop filter and the charge pump, and the $\Sigma - \Delta$ quantization noise. The filter noise was described on the basis of the Nyquist equation generalized to complex resistances. It may contribute significantly to the overall noise, especially for low capacitance values used in fully integrated frequency synthesizers. The reduction of phase noise and jitter due to correction of the common phase error by digital baseband processing in OFDM systems was also included in the model. If the carrier spacing is larger than the loop bandwidth, the correction of the common phase error results in a significant reduction of the rms phase jitter.

References

- Perrot, M. H., Trott, M. D., and Sodini, C. G.: A Modeling Approach for $\Sigma - \Delta$ Fractional-N Frequency Synthesizers Allowing Straightforward Noise Analysis, *IEEE Journal of Solid-State Electronics*, 37, 1028–1038, 2002.
- Stott, J.: The effects of phase noise in COFDM, *BBC Research and Development*, EBU Technical Review, Summer 1998.
- Herzel, F., Piz, M., and Grass, E.: Frequency Synthesis for 60 GHz OFDM Systems, in: *Proceedings of the 10th International OFDM Workshop (InOWo'05)*, Hamburg, Germany, 303–307, 2005.
- Winkler, W., Borngräber, J., Heinemann, B., and Herzel, F.: A Fully Integrated BiCMOS PLL for 60 GHz Wireless Applications, *ISSCC Digest of Technical Papers*, San Francisco, 406–407, 2005.
- Lee, T. H. and Hajimiri, A.: Oscillator Phase Noise: A Tutorial, *IEEE Journal of Solid-State Circuits*, 35, 326–336, 2000.
- Mehrotra, A.: Noise Analysis of Phase-locked Loops, *IEEE Transactions on Circuits and Systems-I: Fundamental Theory and Applications*, 49, 1309–1316, 2002.

- Lee, D. C.: Analysis of jitter in phase-locked loops, *IEEE Transactions on Circuits and Systems-II: Analog and Digital Signal Processing*, 49, 704–711, 2002.
- Demir, A.: Phase Noise and Timing Jitter in Oscillators with Colored-Noise Sources, *IEEE Transactions on Circuits and Systems-I: Fundamental Theory and Applications*, 49, 1782–1791, 2002.
- Kundert, K.: Predicting the Phase Noise and Jitter of PLL-Based Frequency Synthesizers, in: *Phase-Locking in High-Performance Systems*, edited by: Razavi, B., John Wiley & Sons, 46–69, 2003.
- Centurelli, F., Ercolani, A., Scotti, G., Tommasino, P., and Trifiletti, A.: “Behavioral Model of a Noisy VCO for Efficient Time-Domain Simulation, *Microwave and Optical Technology Letters*, 40, 352–354, 2004.
- Herzel, F., Winkler, W., and Borngreber, J.: Jitter and Phase Noise in Oscillators and Phase-locked Loops, in: *Proc. SPIE Symp. Fluctuations and Noise, Maspalomas, Spain*, 5473, 16–26, 2004.
- Navid, R., Jungemann, C., Lee, T. H., and Dutton, R. W.: Close-in Phase Noise in Electrical Oscillators, in: *Proc. SPIE Symp. Fluctuations and Noise, Maspalomas, Spain*, 5473, 27–37, 2004.
- Rohde, U. L., Poddar, A. K., and Böck, G.: *The Design of Modern Microwave Oscillators for Wireless Applications*, John Wiley & Sons, 2005.
- Uang, R., Bourde, C., and Bagwell, T.: A SiGe 23 GHz Fractional-N Frequency Synthesizer, online available: <http://www.mpdigest.com/Articles/2004/May2004/centellax>, 2004.
- Estimating PLL Phase Noise, online available: http://www.rfengineer.net/pdf/pll_pn_magisnetworks.pdf, 1998.
- Valero-Lopez, A. Y.: *Design of Frequency Synthesizers for Short Range Wireless Transceivers*, Ph. D. Dissertation, Texas A & M, Sep. 2004.
- Niu, G.: Noise in SiGe HBT RF Technology: Physics, Modelling, and Circuit Implications, *Proceedings of the IEEE*, 93, 1583–1597, 2005.
- Allen, P. E. and Holberg, D. R.: *CMOS Analog Circuit Design*, Oxford University Press, New York, p.118, 1987.
- Miller, B.: A Multiple Modulator Fractional Divider, *IEEE Transactions on Instrumentation and Measurements*, 40, 578–583, 1991.