



A novel conductive sensor-based test method to measure longitudinal wicking of fabrics

S S Suresh¹, D Raja^{1, a}, B Thiyaneswaran², R Gobinath¹, S Kubera Sampath Kumar³, R G Panneerselvam⁴ & M Senthilkumar⁵

¹Department of Fashion Technology, ²Department of Electronics and Communication Engineering, Sona College of Technology, Salem 636 005, India

³Department of Chemical Engineering (Textile Technology), Vignana's University, Guntur 522 213, India

⁴Department of Fashion Technology, KCG College of Technology, Chennai 600 117, India

⁵Department of Textile Technology, PSG Polytechnic College, Coimbatore 641 004, India

Received 5 September 2021; revised received and accepted 11 January 2022

This paper reports the development of novel vertical wicking instrument which is specially designed to measure the wicking behavior of textile fabrics precisely. The instrument is designed using T-shaped test frame fabricated with tribo-electric fibre glass and electrical conductivity sensors. The developed electrical conductive sensors are capable to measure the time taken for the vertical wicking of water through inter-fibre capillaries with respect to height. The wet fabric allows the electrical current flow between two conductive points of sensor and enables the IoT controller circuit to monitor the time taken for wicking. To improve the accuracy of measuring the wicking behavior, tribo-electric fibre glass is used. The tribo electric fibre glass has electrostatic charges on its surface and induces static cling effect. Static cling is the tendency of light objects such as fabrics to stick (cling) to other objects owing to static electricity. The static cling effect attracts the fabric test sample to make it in contact with conductivity sensor array. The wicking process is carried out without causing obstruction to the movement of water through inter-fibre capillaries. The accuracy of the measured data obtained from the novel instrument is compared with the data of manual standard test procedure ($R^2 > 0.97$). The comparison shows that the developed instrument produces more reliable results.

Keywords: Electrical conductivity sensor, Single jersey fabric, Static cling, Tribo-electric glass base, Wicking, Woven fabric

1 Introduction

In textiles, clothing comfort plays an important role for any garment used for sportswear and leisurewear. Every human being sweats during different kinds of activities. Therefore, an important feature of any fabric is how it transports this sweat (perspiration) out of the body surface and makes the wearer feel comfortable. In this regard, wetting, wicking and moisture vapour transmission properties are critical aspects for the performance of clothes.

Especially, wicking behavior of the fabric or garment is more responsible for sweat evaporation during active sports events. Spontaneous transport of a liquid driven into a porous system by capillary forces is termed as 'wicking'. Mahadevan¹ defines that it is the ability of a fabric to take in moisture. Raul² says that the ability of fabric to absorb water,

especially by wicking or capillary action may be observed by timing the rate at which water climbs up a narrow strip of fabric suspended vertically with its lower end dipping into the water.

Kawase *et al.*³ developed the first technique for observing and measuring the liquid rise in textile structure by using a colored liquid. The experimental study to analyze the liquid penetration into fabrics was made in line with the AATCC standard test procedure 197. The wicking height for an equal time interval is recorded for further evaluation. Since it is the manual method, it lacks accuracy. Raja *et al.*^{4,5} developed dynamic sweat transfer tester for analyzing the sweat transfer behavior of multi-weave structure fabrics. It measures sweat/liquid transfer behavior. An automatic wicking test method using image analysis and colour sensor technique was developed in order to automate the longitudinal wicking test and improve the accuracy of wicking measurement. It was particularly useful for conducting wicking

^aCorresponding author.
E-mail: rajaslm@gmail.com

measurement test during the initial rapid wicking process. Zhuang *et al.*⁶ developed a test method to analyze the longitudinal wicking of weft knitted fabrics. In the first part of this research they developed an automatic wicking test method using image analysis technique.

Raja *et al.*^{7,8} made the comparison of different methods to measure the transverse wicking behaviour of fabrics. In this, they measured fabric absorbency rate and total absorbent capacity. Ghali *et al.*⁹ designed a wicking instrument based on the electrical principle. In this case, for measuring the vertical wicking height, the electrical probe is kept in direct contact with the test sample. When light fabric was used for testing there was a difficulty noticed for establishing contact between fabric and probe quite. ShiruiLiua *et al.*¹⁰ developed a sliding-mode tribo-electrification system to measure the charge density on highly porous and deformable materials, such as textile fabrics. Twenty one types of polymer fibres were investigated to evaluate the operational parameters, structures and properties of these textile fabrics. The results show that tribo - electric charge density of fabrics varies, depending upon the fabric surface and its chemical structure

Zhang *et al.*¹¹ tested the electrical resistivity of a textile material, based on the influence of fibre assembly composition. Experiments with different kinds of fibre assemblies clearly show that the electrical resistivity, so defined, is an inherent characteristic reflecting the electrical properties of fibre material and it is independent of sample form, such as fabric, yarn, and fibre.

Parada *et al.*¹² created a dual porosity diffusivity model to replicate the complex dynamic wicking behavior in textiles. They measured wicking within yarns as well as wicking in the spaces between the yarns. Water absorption in the yarn pore system is influenced by the textile structure (woven versus knit), and the maximum moisture content during uptake differs in the void pore system.

Parada *et al.*¹³ also reviewed the advanced imaging technologies for quantification of wicking in textiles. The imaging approaches for wicking in textiles included in this review range from visible light to synchrotron x-ray. The wicking phenomena and its significance are also discussed. The primary wicking experimental setups like strip test and the spot test are presented. Nemcokova *et al.*¹⁴ explored the liquid moisture transfer in textile structures. The research of

dynamic moisture transport of knitted fabrics using sophisticated technologies such as moisture management testers (MMT), thermography, and microtomography devices is the subject of this article. The above two methods required highly sophisticated equipment and safety measure. There are many attempts made to develop test methods for longitudinal wicking. But, in the developed method conductive sensor array is used to attract the fabric, which will give continuous contact between fabric and sensor all the time.

It is presumed that a novel, reliable, cost-effective objective assessment system is needed to measure the wicking behavior. Therefore, in the study, a new instrument has been designed and developed, by which the wicking time taken for the capillary rise of moisture to reach specified height is recorded automatically. This study also discusses the development of its mechanical and electrical components, such as T-shaped test frame, sensor assembly, electronic mother board and thing speak cloud output. The findings of this novel instrument are compared with the findings of the manual standard test procedure.

2 Materials and Methods

2.1 Principle and Design of Instrument

The development of the new vertical wicking instrument is based on the tribo-electric fibre glass material and conductive sensors. The basic principles involved in the designing of instrument are discussed hereunder. Fibre glass has the good static cling effect to attract the test fabric and makes it to contact with conductive sensor. The water is a good conductor of electricity. Between two conductive points of the conductive sensors, the electrical current flow is not established when the dry fabric is in contact with it. Whereas, when the fabric is wet by the water through wicking process, the electrical current flow is established, because water is good conductor of electricity.

In the phase of the new development, tribo-electric fibre glass test frames with conductive sensors have been designed using standard test procedures. The electrostatic charges are distributed over the surface of tribo-electric glass material. The electrical conductive sensors is developed and used to track the vertical wicking process. Each conductive sensor has two conductive points (+ve & -ve), which are normally open circuit type. An array of six conductive

sensors is developed and made to conduct (closed circuit) by the help of wet fabric (wicking process).

The time taken by the water to reach the specific height of the fabric is measured using an array of conductive sensors and the output is processed with the IoT enabled controller. The idea on this approach is that the fabric could be tested in manufacturing location and the client may be able to see the output from his location.

2.2 Fabric Materials

Woven (plain) and knitted fabrics (single jersey) samples of different blend and thickness are used for the study. The static cling effect test and wicking test are made for 20 different sample fabrics. The 20 fabric samples of the same quantity and size are cut in both the warp and weft directions, and all the samples are conditioned for 24 h under standard atmospheric conditions (temperature $20\pm 2^\circ\text{C}$ and relative humidity $65\pm 5\%$). After conditioning, samples are taken for the investigation.

2.3 Development of T-shaped Test Frame

The vertical wicking device setup is shown in Fig. 1. A cubical wooden open enclosure frame is fabricated to hold the wooden T-shaped test frame. The T-shaped test frame consists of the horizontal and vertical arms. The front facing side of vertical arm is layered with the tribo-electric fibre glass of the size; vertical height 30cm, length 4 cm and width 1 cm. The conductive sensor array is fixed vertically above the fibre glass layer. The conductive sensors are fabricated using conductive metal and epoxy printed dot board. Six conductive sensors are fixed one above the other vertically with equal spacing of about 1cm apart. Thus, 6 sensors are required to measure the wicking height of 6 cm.

The mechanical setup of the test frame and sensor assembly is shown side by side in Fig.1. It is a cubical hollow wooden frame. The frame width and breath are 2 cm and 2 cm. The dimension (height, width and

breath) of hollow wooden frame setup is $40\text{ cm} \times 22\text{ cm} \times 20\text{ cm}$. The hollow space area of the mechanical assembly is $17,600\text{ cm}^2$. The horizontal pillar of T-shaped frame length, width and breath are 24.5 cm, 2 cm, and 1 cm respectively. Similarly the vertical pillar length, width and breath are 37 cm, 2 cm, and 1 cm respectively. The tribo-electric fibre glass pasted with ruler measurement is fixed in the vertical pillar using pivot at the top and bottom ends. The conductive sensor array consists of 6 sensors, namely Sensor-1 (S1), Sensor-2 (S2), Sensor-3 (S3), Sensor-4 (S4), Sensor-5 (S5), and Sensor-6 (S6). The sensors are fixed vertically one above the other, with the equal spacing of 1cm apart (S1-1cm, S2-2cm, S3-3cm, S4-4cm, S5-5cm and S6-6cm)

The Table 1 shows the sensors locations in the fibre glass scale. The contacts of the each sensor are located in the specified locations. Six sensors are fixed with an equal distance of 1 cm. First sensor fixed at the 1cm marking in the ruler and last sensor fixed at the 6 cm. Number of sensors can be increased depending upon the needs. In order to differentiate the wicking time with respect to wicking height, one centimeter distance is taken in this study.

2.4 Tribo-electric Fibre Glass

The tribo-electric fibre glass material (Fig. 2) is fabricated using silica and tested for the static cling property. The tribo-electric effect is a type of contact electrification which causes static cling in clothes. The static cling is the tendency for light weight objects such as clothes to stick (cling) to other objects owing to static electricity.

To study the static electricity and static cling property, an electroscope device is developed using aluminum conductor material. The electroscope is able to detect the static charge distribution over the surface of glass, plastic, clothes, styro-foam and metals. Table 1 shows the quantity of static charges

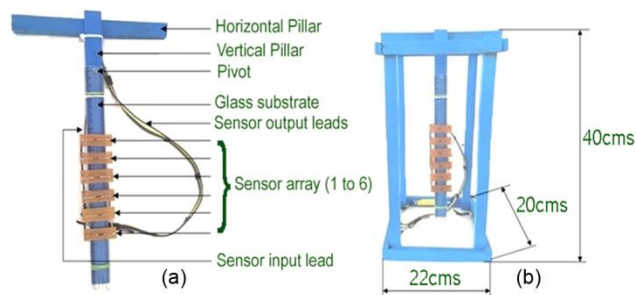

Fig. 1 — Test frame (a) and sensor assembly (b)

Table 1 — Static-charge of different materials measured using digital coulomb meter

Base material	Contact material	Charge type	Static charge milli amps
Plastic	Silk	-ve	2.9
	Wool	-ve	3.4
Normal glass	Silk	+ve	2.1
	Wool	+ve	2.5
Fibre glass	Silk	+ve	2.8
	Wool	+ve	3.2
Styrofoam	Wool	+ve and -ve	4.5
	Silk	+ve and -ve	4.8

present in different materials tested using digital coulomb meter.

2.5 Conductive Sensor

The conductive sensor is fabricated using the copper dotted epoxy PCB. Figure 3 shows the sample of one conductive sensor.

Each of the conductive sensors has two terminals. Input copper lead (+ve) and output copper lead (0v) which are spaced 0.5cm apart. The potential applied between the two terminals is in range of +4.0 V to 4.5 V. The fabric gets its contact with the conductive

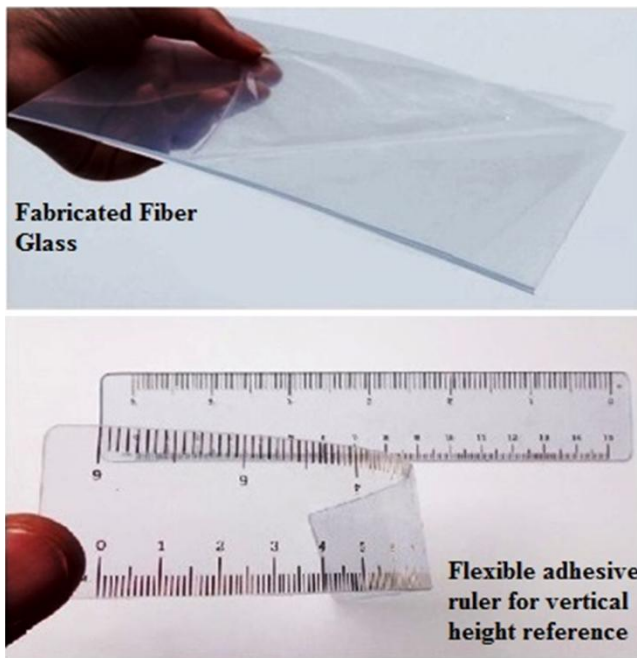

Fig. 2 — Fabricated fibre glass and flexible adhesive ruler

sensor terminals lively. When the fabric is dry, there will be high resistance in between, and the leakage current cannot travel through dry fabric. When the fabric is wet, there will be potential created between two copper board terminals and the flow of current decreases the barrier resistance value. This analog potential value is sensed and derived as wicking point. The array of six conductive sensors is fabricated and is fixed over the surface of glass substrate.

2.6 Sensor Arrays Circuit and Mother Board

The circuit diagram of conductive sensor array is shown in Fig. 4. A +5V input line is connected with the sensor. The output consists of 6 lines from each sensor. A +5V input is connected in the sensor input lead. The input lead is connected with the Sensor-1, Sensor-2, Sensor-3, Sensor-4, Sensor-5, and Sensor-6. Output leads are taken from sensor array which are from Sensor-1, Sensor-2, Sensor-3, Sensor-4, Sensor-5, and Sensor-6.

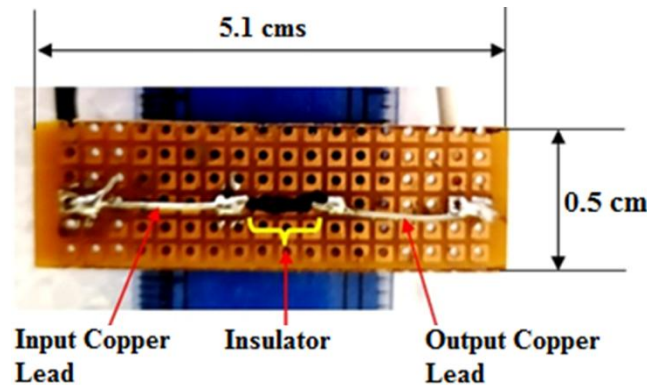

Fig. 3 — Development of conductive sensor module assembly

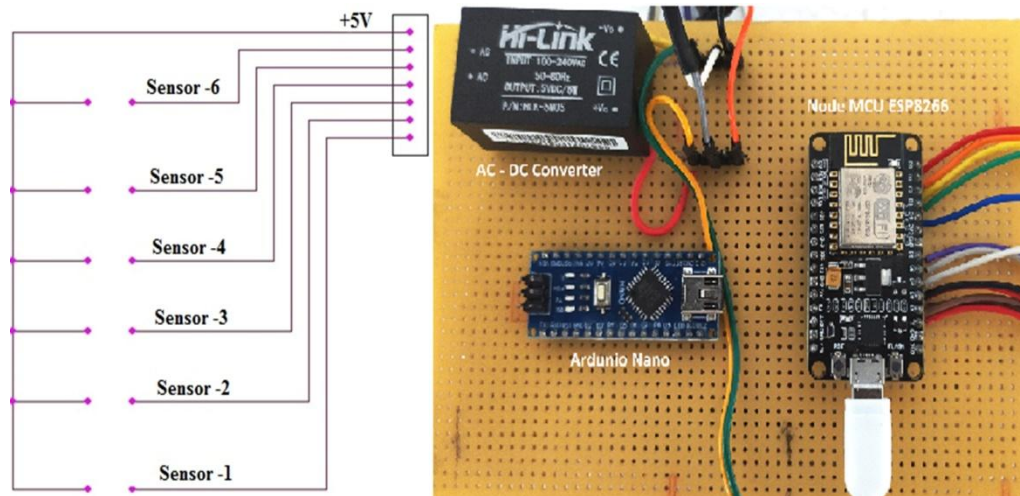

Fig. 4 — Sensor array connection diagram with fabricated mother board

The contact between the input path and sensor output path in the proposed system is made by the wet cloth. When fabric is dipped in water, the water starts wicking in vertical direction. The first conductive sensor is placed at 1 cm height from fabric base. Once the wicking starts, the wet cloth acts as conductor. Due to the presence of conductor, the sensor input voltage will reach the sensor output side.

The sensor arrays outputs are connected with the Arduino nano board analog channels and the nano board outputs are connected with the NodeMCU board (Table 2) The sensors give the output voltage between +4V and 4.6V, when the fabric is in wet condition. The output voltage will vary from +4V to 4.6V, depending on the fabric resistivity. If the fabric is in dry condition, the sensors give the +0V output. The Arduino nano board is used to convert the analog signal into digital signal. The primary role of nano board is to sense the fabric wicking time and share the computed wicking time at each sensor levels to the ‘think speak’ cloud server.

2.7 Method of Measurement

Water is the wicking liquid. The water is filled only at the moment of starting the wicking test after completion of the basic instrument setup. The test

Table 2 — Conductive sensor connection details and their interface pins in nano board

Sensor description	Arduino nano analog	Arduino nano digital	NodeMCU digital
Sensor-1 (S1)	A0	D2	D0
Sensor-2 (S2)	A1	D3	D1
Sensor-3 (S3)	A2	D4	D2
Sensor-4 (S4)	A3	D5	D3
Sensor-5 (S5)	A4	D6	D4
Sensor-6 (S6)	A5	D7	D5

fabric specimen is clamped to the horizontal pillar of the T-shaped vertical frame as shown in Fig. 5. The static cling effect of glass makes the fabric to get its contact with conductive sensor array. A 500 mL beaker is placed at the bottom and water is poured into beaker until it rises to the level to touch the base of vertical frame.

The bottom edge of the test frame and the bottom edge of the fabric are kept at equal level. The instrument is switched on and positive ends of all conductive sensor points (+ve) are energized.

A lead of silver conductive wire leads (+ve and -ve) is placed at the base of vertical pillar of T-shaped vertical frame. The two silver conductive leads get electrically connected by means of water and this triggers the instrument circuit to start recording the time for wicking process. As the water ascends from bottom of fabric to 1st conductive sensor in the test frame, the sensor is activated through fabric wicking and time is recorded. The water starts to wick vertically and crosses the 2nd, 3rd, and finally to 6th sensor. The corresponding wicking height and time are simultaneously recorded and processed using IoT enabled controller. The same can be configured and transmitted wirelessly through the ‘thing speak’ cloud server using the Application Program Interface (API).

The instant wicking time difference between each conductive sensor is also obtained from the instrument. The similar kind of procedure is followed to measure the vertical wicking of any fabric respectively. The complete experimental setup is shown in Fig. 6.

It consists of mechanical assembly, sensor board, controller board and laptop. The NodeMCU is also connected with the Wi-Fi internet connectivity. The

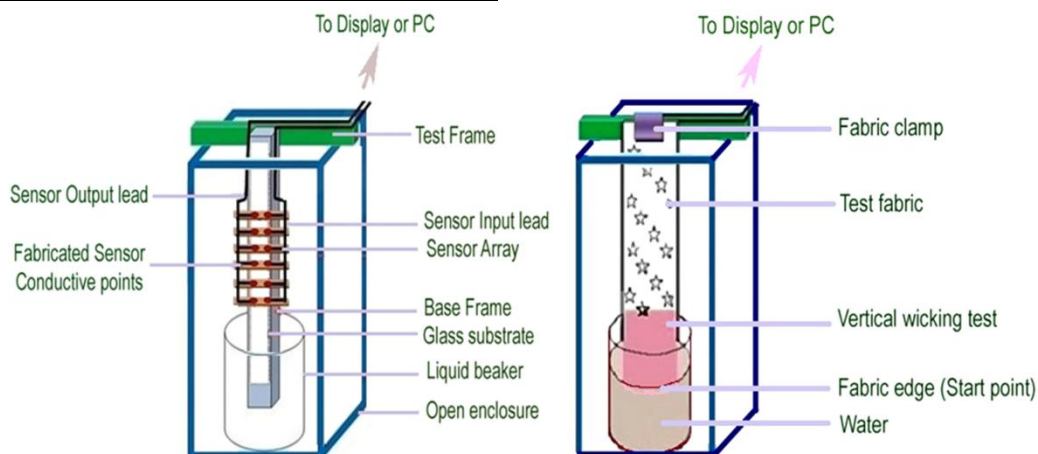

Fig. 5 — Method of vertical wicking measurement

laptop shown in the Fig. 6 also enabled with the internet connectivity. Based on all the sensor output, wicking times at various levels are updated in the cloud server. The idea on this approach is that the fabric could be tested in manufacturing location and the client may be able to see the output from his location.

3 Results and Discussion

The rate of longitudinal wicking capability for the produced samples is assessed in the novel vertical wicking tester using the newly developed static cling

and conductive sensor methodology. For all the samples, vertical wicking tests are carried out by the new instrument as well manual study for both wale/warp and course/weft directions. The comparison of these two is given in Table 3.

3.1 Validation of Instrument

To validate the developed instrument, the test results of the existing standard manual method (M) and the results of the instrument method (I) are correlated with Pearson correlation coefficient, as shown below:

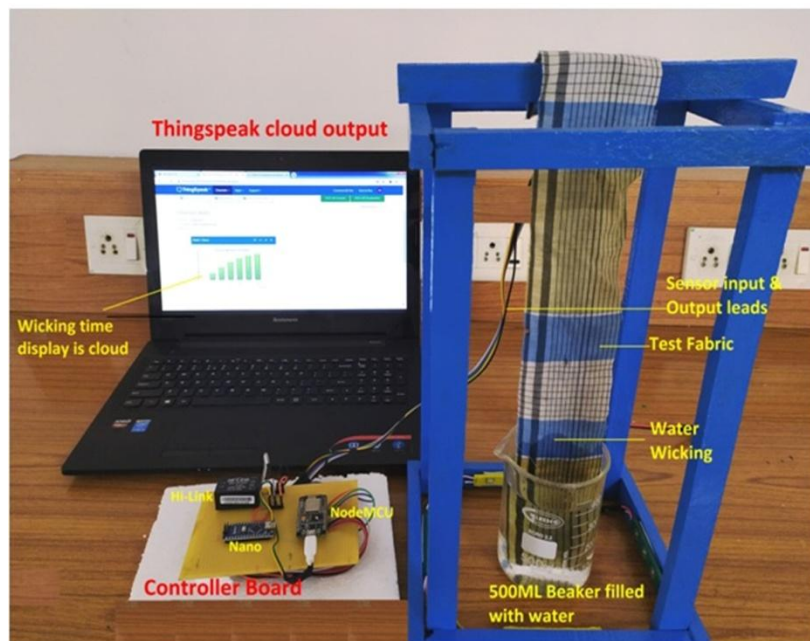

Fig. 6 — Practical experimental setup of the instrument

Table 3 — Comparison of wicking time of different fabrics recorded from the novel instrument (I) and manual (M) methods

Fibre	Fabric type	Thickness mm	Static cling effect	Wicking direction	Wicking time, min											
					1 cm(S1)		2 cm(S2)		3 cm(S3)		4 cm(S4)		5 cm(S5)		6 cm(S6)	
					I	M	I	M	I	M	I	M	I	M	I	M
Polyester	Woven	0.31	Excellent	Warp	1.1	1.2	3.3	3.2	6.6	6.2	10.2	9.9	12.7	12.4	18.3	17.9
				Weft	1.2	1.3	3.8	3.6	7.3	6.7	11.1	10.2	13.8	12.7	20.0	18.2
Polyester-cotton	Woven	0.35	Good	Warp	1.3	1.2	4.2	3.9	8.9	7.8	13.5	12.7	16.9	15.8	24.1	22.7
				Weft	0.9	0.8	2.5	2.5	5.1	4.8	7.8	7.4	9.8	9.3	14.2	13.6
Cotton	Woven	0.603	Normal	Warp	0.7	0.7	2.4	2.3	4.6	4.3	7.4	7.2	9.2	9.0	13.5	13.1
				Weft	0.6	0.6	2.2	2.1	4.3	4.1	6.9	6.7	8.7	8.4	12.7	12.4
Eri silk	Woven	0.89	Excellent	Warp	0.7	0.6	2.0	1.9	4.0	3.8	6.4	6.2	8.0	7.7	11.7	11.3
				Weft	0.6	0.6	1.9	1.8	3.9	3.7	6.3	6.1	7.8	7.6	11.5	11.1
Wool	Woven	1.1	Excellent	Warp	0.9	0.8	2.3	2.1	4.2	4.1	6.8	6.5	8.2	8.1	11.9	11.7
				Weft	0.8	0.7	2.1	2.0	4.0	3.9	6.4	6.3	7.9	7.7	10.8	10.5
Jute	Woven	0.7	Normal	Warp	1.5	1.3	2.4	2.2	3.6	3.8	5.3	5.1	6.2	6.0	9.8	9.5
				Weft	1.6	1.4	2.5	2.4	3.7	3.4	5.4	5.2	6.4	6.2	7.9	8.1

(Contd.)

Table 3 — Comparison of wicking time of different fabrics recorded from the novel instrument (I) and manual (M) methods (Contd.)

Fibre	Fabric type	Thickness mm	Static cling effect	Wicking direction	Wicking time, min											
					1 cm(S1)		2 cm(S2)		3 cm(S3)		4 cm(S4)		5 cm(S5)		6 cm(S6)	
					I	M	I	M	I	M	I	M	I	M	I	M
Linen	Woven	0.72	Excellent	Warp	1.2	1.1	2.1	2.3	2.5	2.4	3.1	3.3	3.1	3.3	3.5	3.4
				Weft	1.3	1.2	2.2	2.1	2.7	2.5	3.2	3.4	3.2	3.5	3.7	3.5
Satin	Woven	0.65	Normal	Warp	4.5	4.3	6.3	7.1	7.2	8.0	9.5	9.7	11.2	10.8	12.3	12.1
				Weft	2.1	1.9	4.9	4.6	7.3	7.9	9.9	9.8	11.4	10.7	12.1	11.9
Nylon	Woven	0.75	Excellent	Warp	3.1	2.9	4.1	3.9	5.9	5.8	6.5	6.2	6.9	6.7	7.9	7.7
				Weft	2.9	2.7	3.9	3.6	5.7	5.5	6.3	6.1	6.7	6.6	7.6	7.5
100% acrylic	Single jersey	0.58	Excellent	Course	0.6	0.5	4.3	4.0	5.6	6.2	7.3	7.6	8.6	8.7	10.5	10.2
				Wale	0.7	0.6	4.2	4.1	5.4	5.6	7.1	7.3	8.2	8.0	9.8	9.7
Cotton/acrylic (50/50)	Single jersey	0.69	Good	Course	1.8	2.1	2.3	2.0	2.8	2.6	3.0	3.2	3.0	3.3	3.1	3.0
				Wale	1.7	1.9	2.4	2.6	2.9	2.7	3.1	3.3	3.1	3.4	3.2	3.5
Cotton/acrylic (85/15)	Single jersey	0.67	Normal	Course	2.0	2.3	3.3	3.1	3.5	3.2	3.6	3.3	3.6	3.3	3.6	3.4
				Wale	1.9	1.8	3.2	3.4	3.6	3.7	3.8	3.5	3.5	3.6	3.7	3.9
Viscose	Single jersey	1.07	Good	Course	0.6	0.7	1.4	1.6	2.5	2.5	3.4	3.7	4.2	4.3	5.4	5.7
				Wale	0.7	0.8	1.5	1.7	2.1	2.3	3.5	3.6	4.1	4.2	5.6	5.7
Bamboo	Single jersey	0.93	Normal	Course	1.2	1.3	2.2	2.5	3.6	3.7	5.2	5.4	6.1	6.4	7.8	8.0
				Wale	1.3	1.4	2.4	2.7	3.5	3.6	5.3	5.5	6.3	6.5	7.9	8.1
Polyester fine cool	Single jersey	0.9	Excellent	Course	2.6	2.4	3.1	2.8	4.2	4.0	5.1	4.7	5.6	5.3	6.3	5.9
				Wale	2	1.9	3.2	3.0	4	3.9	4.8	4.6	5.3	5.1	6.1	5.9
Polyester cool max	Single jersey	0.7	Excellent	Course	6	5.8	7.3	7.1	8.2	8.0	10	9.7	11.1	10.8	12.1	11.9
				Wale	2	1.8	7.2	7.0	8.3	8.0	10.1	9.8	11.1	10.9	12.0	11.7
100 Tencel LF	Single jersey	0.9	Normal	Course	3.5	3.2	4.6	4.3	6.2	6.0	6.8	6.6	7.0	6.7	8.1	7.8
				Wale	3.1	3.0	4.2	3.9	6.1	5.8	6.6	6.3	6.9	6.6	7.9	7.5
Cotton/coolmax 50/50	Single jersey	0.9	Normal	Course	7.8	7.5	9.3	9.0	11.2	11.0	12.6	12.3	13.7	13.7	15.0	14.8
				Wale	7.7	7.5	9.4	9.1	11.0	10.7	12.4	12.1	13.5	13.1	14.9	14.6
100 Soybean	Single jersey	0.9	Good	Course	4.2	4.0	5.6	5.3	7.2	6.9	8.5	8.3	9.1	8.7	10.6	10.4
				Wale	3.9	3.6	5.4	5.3	7.1	6.7	8.3	8.1	8.8	8.5	10.4	10.1
Loycell rayon	Single jersey	0.8	Good	Course	3.9	3.5	5.1	4.7	6.8	6.2	7.3	6.8	7.6	7.1	8.6	8.2
				Wale	3.5	3.2	4.7	4.2	6.3	5.9	7.1	6.4	7.5	6.9	8.3	7.9

$$r = \frac{\sum(x - \bar{x})(y - \bar{y})}{\sqrt{\sum(x - \bar{x})^2 \sum(y - \bar{y})^2}}$$

where x is the wicking time of Instrument method (I); and y , the wicking time of manual method (M).

The wicking time in minutes measured through manual and instrument methods have Pearson correlation coefficient (R^2) as 0.997, 0.970, 0.995, 0.992, 0.995 and 0.996 for the wicking height at 1, 2, 3, 4, 5 and 6 cm respectively. The results prove that the developed instrument is consistent and reliable for performing the standard vertical wicking tests. Instrument test results are stored in cloud for future reference. The stored wicking data can be used for future analysis to understand wicking characteristics with respect to fibre, yarn count, fabric weave type, thickness and finish,

4 Conclusion

In the new development, electrostatic cling property of textile fabric is used as a key element to attract the fabric and make it to have self-contact with the conductive sensor array. The novel vertical wicking tester has been designed and developed, to measure the wicking time versus wicking height of fabrics objectively. Special electrical conductive sensors are developed to measure the wicking time using electrical conductivity techniques. Also the wicking data can be viewed anywhere with the newly developed IoT controller. The fabric could be tested in manufacturing location and the client may be able to see the output from his location. To validate the newly developed novel instrument, 20 different types of woven and knitted fabric samples are tested. The test results are precise and have a high correlation ($R^2 > 0.97$), as compared to the standard manual method.

References

- 1 Mahadevan M G, *Dictionary of Textile* (Abhishek Publications, New Delhi), 2004, 1.
- 2 Raul J, *Textile Testing* (APH Publishing Corporation, New Delhi), 2005, 248.
- 3 Kawase T, Sekoguchi S, Fujii T & Mingawa M, *Text Res J*, 56 (7) (1986) 409.
- 4 Raja D, Babu V R, Senthilkumar M, Ramakrishnan G & Kannan N, *J Industrial Text*, 44(2) (2014) 211.
- 5 Chinnadurai S, Raja D, Priyalatha S, Suresh S S & Prakash C, *J Natural Fibres*, <https://doi.org/10.1080/15440478.2020.1848731> (2020).
- 6 Zhuang Q, Harlock S C & Brook D B, *J Text Inst*, 93(1) (2002) 88.
- 7 Raja D, Ramakrishnan G, Babu V R, Senthilkumar M & Sampath M B, *J Industrial Text*, 43(3) (2014) 366.
- 8 Raja D, Prakash C, Ramakrishnan G & Koushik C V, *J Text Inst*, 105 (8) (2014) 842.
- 9 Ghali K, Jones B & Tracy, *Text Res J*, 64 (2) (1994) 106.
- 10 ShiruiLiua, Wei Zhenga B, BaoYanga & Xiaoming Taa, *Nano Energy*, 53 (2018) 38.
- 11 Zhang L, Lin S, Hua T, Huang B, Liu S & Tao X, *Advanced Energy Materials*, 8(26) (2018) 88.
- 12 Marcelo Parada, Xiaohai Zhou, Dominique Derome, Rene Michel Rossi & Jan Carmeliet, *Text Res J*, 89 (17) (2019) 3519.
- 13 Parada M, Derome D, Rossi R M, Carmeliet J, *Text Res J*, 87(1) (2017) 110
- 14 Renata Nemcokova, Viera Glombikova & Petra Komarkova, *A Res J*, 15(4) (2015) 233.