



February 2022

Application of the Combinatorial Nullstellensatz to Integer-magic Graph Labelings

Richard M. Low

San Jose State University, richard.low@sjsu.edu

Dan Roberts

Illinois Wesleyan University, drobert1@iwu.edu

Follow this and additional works at: <https://digitalcommons.georgiasouthern.edu/tag>



Part of the [Discrete Mathematics and Combinatorics Commons](#)

Recommended Citation

Low, Richard M. and Roberts, Dan (2022) "Application of the Combinatorial Nullstellensatz to Integer-magic Graph Labelings," *Theory and Applications of Graphs*: Vol. 9: Iss. 1, Article 3.

DOI: 10.20429/tag.2022.090103

Available at: <https://digitalcommons.georgiasouthern.edu/tag/vol9/iss1/3>

This article is brought to you for free and open access by the Journals at Digital Commons@Georgia Southern. It has been accepted for inclusion in Theory and Applications of Graphs by an authorized administrator of Digital Commons@Georgia Southern. For more information, please contact digitalcommons@georgiasouthern.edu.

Application of the Combinatorial Nullstellensatz to Integer-magic Graph Labelings

Cover Page Footnote

The origins of this research began many years ago in 2006. During a conversation with the first author, Stephen G. Hartke proposed a prototype polynomial and the Combinatorial Nullstellensatz as a possible tool to analyze \mathbb{Z}_p -magic graph labelings. Although we tried to pursue this research direction, we were not successful at the time. Now (many years later), the seed of Stephen's idea has borne fruit and the first author wishes to thank Stephen. The second author was supported by a grant from Illinois Wesleyan University. Part of this work was conducted while visiting the first author during a sabbatical.

Abstract

Let A be a nontrivial additive abelian group and $A^* = A \setminus \{0\}$. A graph is A -magic if there exists an edge labeling f using elements of A^* which induces a constant vertex labeling of the graph. Here, the induced label on a vertex is obtained by calculating the sum of the edge labels adjacent to that vertex. Such a labeling f is called an A -magic labeling and the constant value of the induced vertex labeling is called an A -magic value. In this paper, we use the Combinatorial Nullstellensatz to show the existence of \mathbb{Z}_p -magic labelings (prime $p \geq 3$) for various graphs, without having to construct the \mathbb{Z}_p -magic labelings. Through many examples, we illustrate the usefulness and limitations in applying the Combinatorial Nullstellensatz to the integer-magic labeling problem. Finally, we focus on \mathbb{Z}_3 -magic labelings and give some results for various classes of graphs.

1 Introduction

Let $G = (V, E)$ be a connected simple graph. For any nontrivial additive abelian group A , let $A^* = A \setminus \{0\}$. A mapping $f : E(G) \rightarrow A^*$ is called an *edge labeling* of G . Any such edge labeling induces a *vertex labeling* $f^+ : V(G) \rightarrow A$, defined by $f^+(v) = \sum_{uv \in E(G)} f(uv)$. If there

exists an edge labeling f whose induced mapping f^+ on $V(G)$ is a constant map, we say that f is an *A -magic labeling* of G and that G is an *A -magic graph*. The corresponding constant is called an *A -magic value*. A -magic graphs were first introduced by Lee, Lee, Sun, and Wen in [8]. If G has a \mathbb{Z}_k -magic labeling (for some $k \geq 2$), then G is an *integer-magic graph*. The *integer-magic spectrum* of a graph G is the set $\text{IM}(G) = \{k \geq 2 : G \text{ is } \mathbb{Z}_k\text{-magic}\}$. Many results on these topics can be found cited in Gallian's dynamic survey of graph labelings [2], as well as in the mathematical literature.

2 The Combinatorial Nullstellensatz

In [1], Alon proved the following result and successfully applied it to problems in additive number theory and graph theory.

Theorem 2.1. (*Combinatorial Nullstellensatz*). *Let $f = f(x_1, \dots, x_m)$ be a polynomial of degree d over a field \mathbb{F} . Suppose that the coefficient of the monomial $x_1^{t_1} \cdots x_m^{t_m}$ in f is nonzero and $t_1 + \cdots + t_m = d$. If S_1, \dots, S_m are subsets of \mathbb{F} with $|S_i| \geq t_i + 1$, then there exists an $\underline{x}' = (x'_1, x'_2, \dots, x'_m) \in S_1 \times \cdots \times S_m$ for which $f(\underline{x}') \neq 0$.*

For example, let $f(x_1, x_2, x_3, x_4) = x_1^4 x_2 x_3 - 2x_1^5 + x_1^2 x_2^2 x_3^2 + x_4^2 \in \mathbb{Z}_3[x_1, x_2, x_3, x_4]$. We will apply Theorem 2.1 on the term $x_1^2 x_2^2 x_3^2$ in f . Note that $\deg(f) = 6 = \deg(x_1^2 x_2^2 x_3^2)$. Since the exponents of x_1, x_2 and x_3 (in $x_1^2 x_2^2 x_3^2$) are all 2, we must have $|S_i| = 3$ for $1 \leq i \leq 3$. As the exponent of x_4 (in $x_1^2 x_2^2 x_3^2$) is 0, our choice for S_4 must satisfy $1 \leq |S_4| \leq 3$. Thus, we choose $S_1 = \{0, 1, 2\}$, $S_2 = \{0, 1, 2\}$, $S_3 = \{0, 1, 2\}$ and $S_4 = \{2\}$. Then, Theorem 2.1 implies that there exist $s_i \in S_i$, where $1 \leq i \leq 4$, such that $f(s_1, s_2, s_3, s_4) \neq 0$. Note that the Combinatorial Nullstellensatz cannot be applied to any of the other monomial terms in f .

In relatively short order, the Combinatorial Nullstellensatz would soon become a powerful tool in extremal combinatorics [6]. With regards to graph labeling and coloring problems, it has been used to prove theorems on anti-magic labelings, neighbor sum distinguishing total colorings, and list colorings [4, 11, 13]. For a recent research monograph on the Combinatorial Nullstellensatz and graph coloring problems, the reader is directed to [17].

When studying A -magic labeling problems, there are two prevailing techniques that are often used to prove results. Either a construction of a desired labeling is obtained through ingenuity, or one shows the non-existence of the labeling (via proof by contradiction). In practice, these methods can be time-consuming and difficult to use.

We use the Combinatorial Nullstellensatz to show that certain graphs are \mathbb{Z}_p -magic (prime $p \geq 3$), without having to construct an actual \mathbb{Z}_p -magic labeling. As far as the authors know, this is the first time that a nonconstructive method has been used to analyze integer-magic graph labelings. Section 3 contains some examples to illustrate this approach.

First, we note a few important facts which are known about \mathbb{Z}_k -magic labelings. Lemmas 2.3 and 2.4 are found in [9], whereas Lemma 2.2 is a slight generalization of a lemma found in [9].

Lemma 2.2. *For a graph G , let $i(v)$ denote the number of edges (multiple edges, loops) incident to $v \in V(G)$. Then, G is \mathbb{Z}_2 -magic $\iff i(v)$ are of the same parity, for all $v \in V(G)$.*

Lemma 2.3. *If G is \mathbb{Z}_k -magic and $k|n$, then G is \mathbb{Z}_n -magic.*

Remark. The converse of Lemma 2.3 is not true, in general. For example, it was shown in [7] that $\text{IM}(K_4 - \{uv\}) = \{4, 6, 8, \dots\}$. In particular, $K_4 - \{uv\}$ is \mathbb{Z}_6 -magic. However, $K_4 - \{uv\}$ is not \mathbb{Z}_3 -magic.

Lemma 2.4. *Let p be prime. If G is \mathbb{Z}_p -magic for some magic value $t \neq 0$, then G is \mathbb{Z}_p -magic with magic value t' for any nonzero $t' \in \mathbb{Z}_p$.*

Lemmas 2.2 and 2.3 allow us to focus on primes $p \geq 3$. Because of Lemma 2.4, it suffices to look at \mathbb{Z}_p -magic labelings with magic values equal to 0 and 1.

Throughout this paper, we only consider connected simple graphs. Let $G = (V, E)$, where $|V(G)| = n$ and $E(G) = \{x_1, x_2, \dots, x_m\}$. Let $p \geq 3$ be prime and $t \in \{0, 1\}$. We define the polynomials f_t in $\mathbb{Z}_p[x_1, \dots, x_m]$ in the following way:

$$f_t(\underline{x}) = f_t(x_1, \dots, x_m) = \prod_{v \in V(G)} \left[1 - \left(t - \sum_{v \in x_j} x_j \right)^{p-1} \right].$$

The motivation for defining f_t in this way is to capture whether or not each induced vertex label is equal to t . In the product, each vertex of G corresponds to one factor. Each factor is designed to evaluate to 1 if the corresponding induced vertex label is equal to t , and evaluates to 0 otherwise. Therefore the product evaluates to either 0 or 1, as the coefficients of f_t come from the field \mathbb{Z}_p . Given a particular input vector, the polynomial f_t returns 1 if and only if that input vector is a \mathbb{Z}_p -magic labeling of G with magic value t .

Remark. Note that $\deg(f_t(\underline{x})) = |V(G)| \cdot (p - 1)$. This follows from:

1. There are $|V(G)|$ factors in $f_t(\underline{x})$.
2. Each of the factors is of degree $p - 1$.
3. Theorem in [5]: Let R be a commutative ring with unity and $g, h \in R[x_1, x_2, \dots, x_m]$. If R has no zero divisors, then $\deg(gh) = \deg(g) + \deg(h)$.

Observations. Let \underline{x}' be an m -tuple in $\mathbb{Z}_p^* \times \mathbb{Z}_p^* \times \dots \times \mathbb{Z}_p^*$. Then, we note the following:

1. $f_t(\underline{x})$ is defined for all connected multigraphs G .
2. The range of $f_t(\underline{x})$ is $\{0, 1\}$. This follows from the fact that each factor of f_t takes on a value of 0 or 1, due to Fermat's Little Theorem [5]: If p is prime, then $a^p = a$ for all $a \in \mathbb{Z}_p$.
3. $f_0(\underline{x}') = 1 \Rightarrow \underline{x}'$ is a \mathbb{Z}_p -magic labeling of G with magic value 0.
4. $f_1(\underline{x}') = 1 \Rightarrow \underline{x}'$ is a \mathbb{Z}_p -magic labeling of G with magic value 1.
5. $f_0(\underline{x}') = 0$ and $f_1(\underline{x}') = 0 \Rightarrow \underline{x}'$ is not a \mathbb{Z}_p -magic labeling of G with magic value 0 or 1.
6. $f_0(\underline{x}') = 1 \Rightarrow f_1(\underline{x}') = 0$. If $f_0(\underline{x}') = 1$, then \underline{x}' is a \mathbb{Z}_p -magic labeling of G with magic value 0. Thus, \underline{x}' is not a \mathbb{Z}_p -magic labeling of G with magic value 1.
7. $f_1(\underline{x}') = 1 \Rightarrow f_0(\underline{x}') = 0$. This is the contrapositive of Observation 6.

3 Applications and Examples

This section provides a proof of concept for the algebraic approach discussed in Section 2. In particular, we give some examples to illustrate the usefulness and limitations of the Combinatorial Nullstellensatz, when applied to \mathbb{Z}_p -magic labelings of graphs.

Example 1. Let $p = 3$ and H be the first graph in Figure 1. Then, $f_1(\underline{x}) \in \mathbb{Z}_3[x_1, x_2, \dots, x_7]$, where

$$f_1(\underline{x}) = [1 - (1 - x_1)^2] \cdot [1 - (1 - (x_2 + x_3))^2] \cdot [1 - (1 - (x_1 + x_2 + x_4 + x_5))^2] \cdot [1 - (1 - (x_3 + x_4 + x_6 + x_7))^2] \cdot [1 - (1 - (x_5 + x_6))^2] \cdot [1 - (1 - x_7)^2].$$

Choosing $\underline{x}' = (1, 2, 2, 2, 2, 2, 1)$, we see that $f_1(\underline{x}') = 1$. The second graph in Figure 1 illustrates this \mathbb{Z}_3 -magic labeling (with magic value 1) of H .

Example 2. Let $p = 3$. Clearly, C_3 cannot be \mathbb{Z}_3 -magic with magic value 0. We also easily see that C_3 has a \mathbb{Z}_3 -magic labeling with magic value 1. However, suppose we did not know

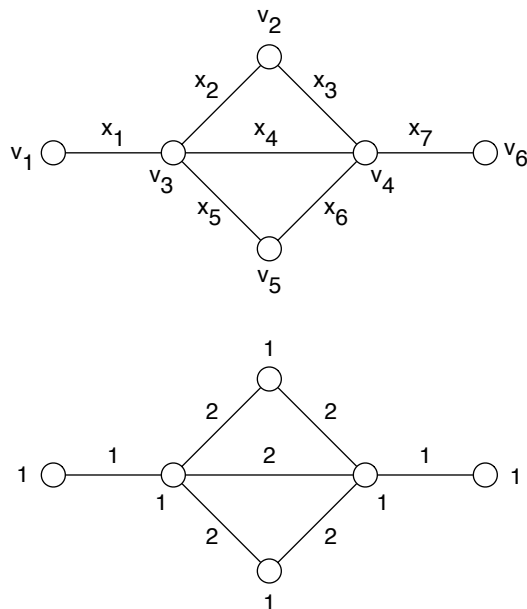

Figure 1: A \mathbb{Z}_3 -magic labeling of H with magic value 1.

of this particular \mathbb{Z}_3 -magic labeling. Let us see if we can use Theorem 2.1 to determine if a \mathbb{Z}_3 -magic labeling (with magic value 1) of C_3 exists. We have $f_1(\underline{x}) \in \mathbb{Z}_3[x_1, x_2, x_3]$, where

$$f_1(\underline{x}) = [1 - (1 - (x_1 + x_3))^2] \cdot [1 - (1 - (x_1 + x_2))^2] \cdot [1 - (1 - (x_2 + x_3))^2].$$

Note that $\deg(f_1(\underline{x})) = 6$. We wish to find a monomial term (degree 6) of $f_1(\underline{x})$, where each exponent of the monomial term is as small as possible. Using Mathematica 12.1 [16], we see that there are thirteen non-vanishing monomial terms of degree 6, modulo 3. None of them satisfy the hypothesis of Theorem 2.1. For example, $2x_1^2x_2^2x_3^2$ is such a monomial term. However, there do not exist subsets S_1, S_2 and S_3 of $\{1, 2\}$ such that $|S_i| \geq 2 + 1$, for $i = 1, 2$ and 3. Hence, we cannot apply Theorem 2.1 in this example.

Remark. Let prime $p \geq 3$. Then, Theorem 2.1 will show that graph G is \mathbb{Z}_p -magic, if the following hold:

1. $|E(G)| \geq \frac{p-1}{p-2} \cdot |V(G)|$. If G does not satisfy this inequality, a straightforward application of the Pigeonhole Principle shows that f_t cannot possibly satisfy the hypothesis of Theorem 2.1. See Example 2.
2. An f_t polynomial (corresponding to G) must have a non-vanishing monomial term, modulo p , (having degree = $\deg(f_t)$), where all the exponents are $\leq p - 2$.

Example 3. Let $p = 3$ and G_3 be the first graph in Figure 2. Then, $f_1(\underline{x}) \in \mathbb{Z}_3[x_1, x_2, \dots, x_{15}]$,

where

$$\begin{aligned}
 f_1(\underline{x}) = & [1 - (1 - (x_1 + x_7 + x_8 + x_{14} + x_{15}))^2] \cdot [1 - (1 - (x_1 + x_2 + x_{11} + x_{12}))^2] \cdot \\
 & [1 - (1 - (x_2 + x_3 + x_8 + x_9))^2] \cdot [1 - (1 - (x_3 + x_4 + x_{12} + x_{13}))^2] \cdot \\
 & [1 - (1 - (x_4 + x_5 + x_9 + x_{10} + x_{15}))^2] \cdot [1 - (1 - (x_5 + x_6 + x_{13} + x_{14}))^2] \cdot \\
 & [1 - (1 - (x_6 + x_7 + x_{10} + x_{11}))^2].
 \end{aligned}$$

Note that $\deg(f_1(\underline{x})) = 14$. Using Mathematica 12.1, we see that $f_1(\underline{x})$ contains the monomial term $-6400x_1x_2 \cdots x_{11}x_{12}x_{14}x_{15}$. Let $S_i = \{1, 2\}$, for $i = 1, 2, \dots, 12, 14, 15$ and $S_{13} = \{1\}$. By Theorem 2.1, we have that $f_1(\underline{x}') \neq 0$, for some $\underline{x}' \in S_1 \times S_2 \times \cdots \times S_{15}$. Thus, $f_1(\underline{x}') = 1$ and we conclude that G_3 has a \mathbb{Z}_3 -magic labeling with magic value 1. With some considerable effort (by hand), one can obtain a \mathbb{Z}_3 -magic labeling of G_3 with magic value 1, as illustrated in the second graph in Figure 2.

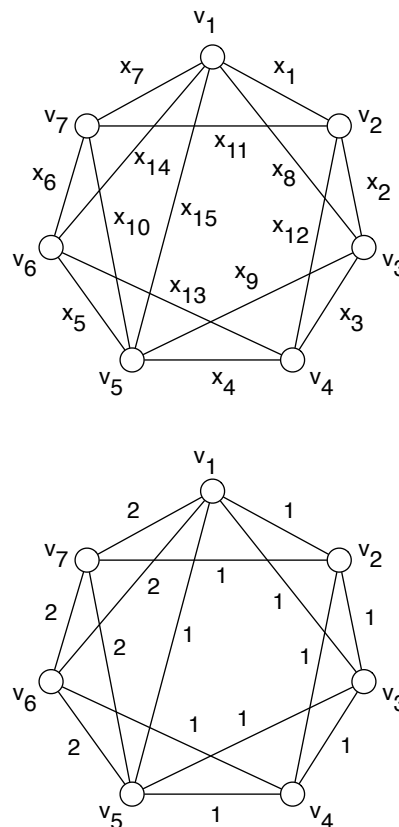

Figure 2: A \mathbb{Z}_3 -magic labeling of G_3 with magic value 1.

Example 4. Let $p = 3$ and G_4 be the graph G1121 from [12] illustrated in Figure 3. Then,

$f_0(\underline{x}) \in \mathbb{Z}_3[x_1, x_2, \dots, x_{14}]$, where

$$f_0(\underline{x}) = [1 - (0 - (x_1 + x_5 + x_6 + x_9 + x_{10} + x_{14}))^2] \cdot [1 - (0 - (x_1 + x_2 + x_{11}))^2] \cdot [1 - (0 - (x_2 + x_3 + x_7 + x_8 + x_{10}))^2] \cdot [1 - (0 - (x_3 + x_4 + x_{13} + x_{14}))^2] \cdot [1 - (0 - (x_4 + x_5))^2] \cdot [1 - (0 - (x_6 + x_7 + x_{11} + x_{12}))^2] \cdot [1 - (0 - (x_8 + x_9 + x_{12} + x_{13}))^2].$$

Note that $\deg(f_0(\underline{x})) = 14$. Using Mathematica 12.1, we see that $f_0(\underline{x})$ contains the monomial term $-4096x_1x_2 \cdots x_{13}x_{14}$. Let $S_i = \{1, 2\}$, for $i = 1, 2, \dots, 14$. By Theorem 2.1, we have that $f_0(\underline{x}') \neq 0$, for some $\underline{x}' \in S_1 \times S_2 \times \cdots \times S_{14}$. Thus, $f_0(\underline{x}') = 1$ and we conclude that $G_4 = G1121$ is \mathbb{Z}_3 -magic with magic value 0.

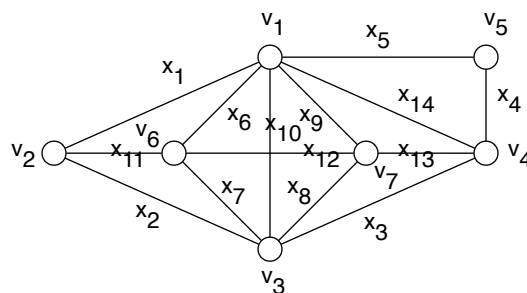

Figure 3: Graph $G_4 = G1121$ from [12].

Example 5. Let $p = 5$ and G_5 be the first graph illustrated in Figure 4. Then, $f_1(\underline{x}) \in \mathbb{Z}_5[x_1, x_2, \dots, x_8]$, where

$$f_1(\underline{x}) = [1 - (1 - (x_1 + x_3))^4] \cdot [1 - (1 - (x_1 + x_2 + x_6 + x_7))^4] \cdot [1 - (1 - (x_2 + x_8))^4] \cdot [1 - (1 - (x_3 + x_4))^4] \cdot [1 - (1 - (x_4 + x_5 + x_7 + x_8))^4] \cdot [1 - (1 - (x_5 + x_6))^4].$$

Note that $\deg(f_1(\underline{x})) = 24$. Using Mathematica 12.1, we see that $f_1(\underline{x})$ contains the monomial term $1069056x_1^3x_2^3 \cdots x_8^3$. Let $S_i = \{1, 2, 3, 4\}$, for $i = 1, 2, \dots, 8$. By Theorem 2.1, we have that $f_1(\underline{x}') \neq 0$, for some $\underline{x}' \in S_1 \times S_2 \times \cdots \times S_8$. Thus, $f_1(\underline{x}') = 1$ and we conclude that G_5 has a \mathbb{Z}_5 -magic labeling with magic value 1. With some considerable effort (by hand), one can obtain a \mathbb{Z}_5 -magic labeling of G_5 with magic value 1, as illustrated in the second graph of Figure 4. Observe that G_5 is an Eulerian graph with an even number of edges. Traveling along an Eulerian circuit, we label the edges with $1, -1, 1, -1, \dots, 1, -1$, which gives a \mathbb{Z}_5 -magic labeling of G_5 with magic value 0.

Example 6. Let $p = 5$ and G_6 be the first graph illustrated in Figure 5. Since $f_1(\underline{x})$ is of degree $6 \cdot 4 = 24$ and $|E(G_6)| = 8$, the only $(\deg 24)$ monomial term which could possibly satisfy the hypothesis of Theorem 2.1 is of the form $\underline{x}_1^3x_2^3x_3^3 \cdots x_8^3$. Using Mathematica 12.1, we see that no such term exists in $f_1(\underline{x})$. Thus, we cannot conclude if G_6 has a \mathbb{Z}_5 -magic

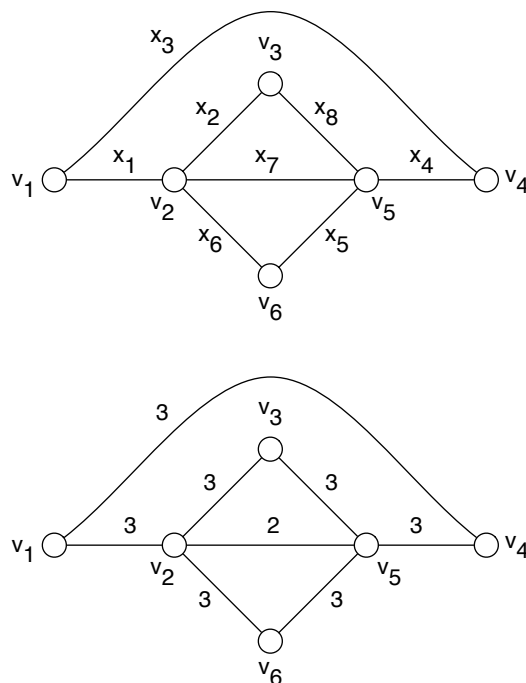

Figure 4: A \mathbb{Z}_5 -magic labeling of G_5 with magic value 1.

labeling (with magic value 1) or not. However, with some considerable effort (by hand), one can obtain a \mathbb{Z}_5 -magic labeling of G_6 with magic value 1, as illustrated in the second graph of Figure 5.

Example 7. Let $p = 3$ and G_7 be the graph illustrated in Figure 6. Note that G_7 is the graph F4 in [12]. The degree of $f_0(\underline{x})$ is 16. Using Mathematica 12.1, we see that $f_0(\underline{x})$ contains the monomial term $14336x_5x_6 \cdots x_{20}$. Let $S_i = \{1, 2\}$ for $i = 5, 6, \dots, 20$, and $S_i = \{1\}$ for $i = 1, 2, 3$ and 4. By Theorem 2.1, we have that $f_0(\underline{x}') \neq 0$, for some $\underline{x}' \in S_1 \times S_2 \times \cdots \times S_{20}$. Thus, $f_0(\underline{x}') = 1$ and we conclude that G_7 has a \mathbb{Z}_3 -magic labeling with magic value 0. Note that in some cases (like this one), Theorem 2.1 can be used to give a lower-bound on the number of different \mathbb{Z}_p -magic labelings. In this particular example, G_7 has at least $2^4 = 16$ different \mathbb{Z}_3 -magic labelings (ignoring symmetry) with magic value 0. This is because S_i can be chosen to be $\{1\}$ or $\{2\}$, for $i = 1, 2, 3$ and 4.

Computations in Examples 2-7 were done on a 2018 Mac mini (3 GHz 6-Core Intel Core i5, 8 GB RAM, macOS Catalina 10.15.5). The ‘‘Computational Time’’ column in Table 1 gives the time required to list a single degree $|V(G)| \cdot (p - 1)$ reduced (mod p) monomial term (of f_i) with exponents $\leq p - 2$, or return \emptyset . Here, the ‘‘AbsoluteTiming’’ and ‘‘MonomialList’’ functions in Mathematica 12.1 were used.

Currently, our Mathematica program has not yet been optimized. We point out that the computational power of Mathematica (or any other software) should be used intelligently, along with Theorem 2.1.

For example, in Table 1 (for graph G_3), we see that 25.8 minutes were required to

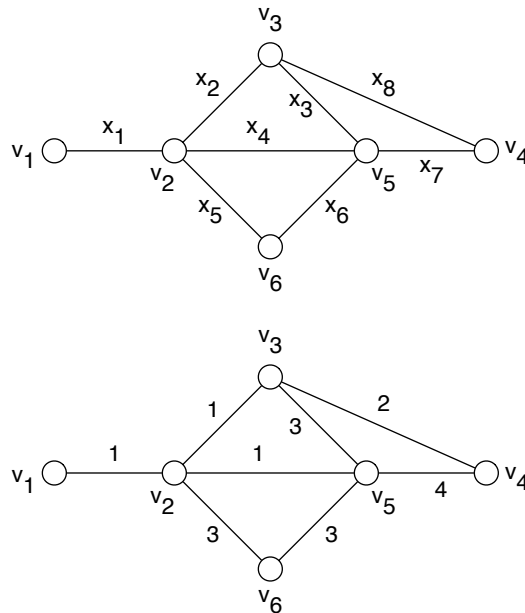

Figure 5: A \mathbb{Z}_5 -magic labeling of G_6 with magic value 1.

Graph G	$ V(G) $	$ E(G) $	\mathbb{Z}_p	Computational Time
C_3	3	3	\mathbb{Z}_3	.001 seconds
G_3	7	15	\mathbb{Z}_3	25.8 minutes
G_4	7	14	\mathbb{Z}_3	3.6 minutes
G_5	6	8	\mathbb{Z}_5	1.5 minutes
G_6	6	8	\mathbb{Z}_5	2.1 minutes
G_7	8	20	\mathbb{Z}_3	> 3.5 days*

Table 1: Runtimes of calculations in Examples 2-7.

obtain a (degree 14) non-vanishing monomial term (with exponents ≤ 1), modulo 3. Even before running our program, we already knew the list of monomials to consider. Because $|E(G_3)| \approx 2 \cdot |V(G_3)|$, there are only $\binom{15}{14} = 15$ monomials which could possibly satisfy the hypothesis of Theorem 2.1. They are of the form $_x_1x_2x_3 \cdots x_{15}$, where exactly one of the x_i is omitted. Using Mathematica (interactively), one can determine the coefficients (mod 3) of these 15 monomials very quickly.

As another example, consider the graph G_4 in Table 1. There, we see that 3.6 minutes were required to obtain a (degree 14) non-vanishing monomial (with exponents ≤ 1), modulo 3. Even before running our program, we know that there is only one monomial which needs to be considered. The unique monomial which could possibly satisfy the hypothesis of Theorem 2.1 is of the form $_x_1x_2x_3 \cdots x_{14}$. Mathematica can determine the coefficient (mod 3) of $_x_1x_2x_3 \cdots x_{14}$ instantly.

The computational time for graph G_7 was greater than 3.5 days and thus, we terminated

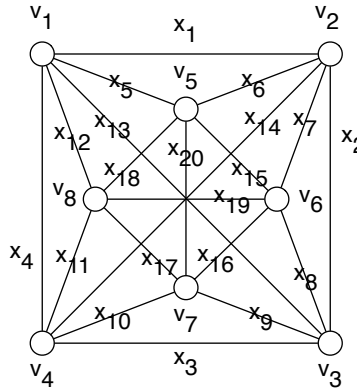

Figure 6: G_7 has a \mathbb{Z}_3 -magic labeling with magic value 0.

our Mathematica program manually. The monomial term in Example 7 was quickly obtained by using Mathematica interactively and examining monomials of a particular form.

4 \mathbb{Z}_3 -magic Graphs

When working with integer-magic labelings, one typically wishes to establish the entire integer-magic spectrum of G . Determining whether or not $3 \in \text{IM}(G)$ is often a degenerate and difficult case to resolve. Currently, there is no known characterization of \mathbb{Z}_3 -magic graphs. Nevertheless, in this section, we use Theorem 2.1 and obtain additional results on \mathbb{Z}_3 -magic graphs.

We first recall the following definition from [3].

Definition. Let G and H be connected simple graphs. The *join* of G and H (denoted by $G + H$) is the graph union $G \cup H$, together with all of the edges joining $V(G)$ and $V(H)$.

Lemma 4.1. *Let G be a \mathbb{Z}_3 -magic graph with magic value 1, where $|V(G)|$ is even. Then, $G + P_2$ has a \mathbb{Z}_3 -magic labeling with magic value 1.*

Proof. For $G + P_2$, let x and y be the vertices of P_2 ; $x_1, x_2, \dots, x_{|V(G)|}$ be the edges joining x to the vertices v_i of G and $y_1, y_2, \dots, y_{|V(G)|}$ be the edges joining y to the vertices v_i of G . Let $\mathcal{L}_{G,1}$ be a \mathbb{Z}_3 -magic labeling of G with magic value 1. Now, consider the following edge labeling of $G + P_2$:

$$\mathcal{L}_{G+P_2,1}(e_i) = \begin{cases} \mathcal{L}_{G,1}(e_i) & \text{if } e_i \in E(G); \\ 1 & \text{if } e_i = x_1, x_3, \dots, x_{|V(G)|-1}, y_2, y_4, \dots, y_{|V(G)|}; \\ 2 & \text{if } e_i = x_2, x_4, \dots, x_{|V(G)|}, y_1, y_3, \dots, y_{|V(G)|-1}; \\ 1 & \text{if } e_i = xy. \end{cases}$$

This gives a \mathbb{Z}_3 -magic labeling of $G + P_2$ with magic value 1. \square

Notation. For $n \geq 3$, let $K_n^* = K_n - \{uv\}$. For $n \geq 4$, let $K_n^{**} = K_n - \{uv, uw\}$. For $n \geq 5$, let $K_n^{***} = K_n - \{uv, uw, uz\}$.

Remark. $K_3^* = P_3$ is not \mathbb{Z}_k -magic, for all $k \geq 2$. In [7], it was shown that $IM(K_4^*) = \{4, 6, 8, \dots\}$. For $n \geq 5$, $K_n^* = K_n - \{uv\}$ was shown to be \mathbb{Z}_3 -magic in [15]. Note that K_4^{**} is isomorphic to C_3 with a pendant edge. A straightforward exhaustive proof can be used to show that K_4^{**} is not \mathbb{Z}_3 -magic.

We now analyze the \mathbb{Z}_3 -magic property for $K_n^{**} = K_n - \{uv, uw\}$ and $K_n^{***} = K_n - \{uv, uw, uz\}$, for $n \geq 5$.

Theorem 4.2. For $n \in \{6, 8, 10, \dots\}$, $K_n^{**} = K_n - \{uv, uw\}$ is \mathbb{Z}_3 -magic.

Proof. Using $f_1(x)$ and Theorem 2.1, we see that K_6^{**} has a \mathbb{Z}_3 -magic labeling $\mathcal{L}_{K_6^{**},1}$ with magic value 1. Note that $K_{n+2}^{**} = K_n^{**} + P_2$. Repeated use of Lemma 4.1 establishes the claim. □

Theorem 4.3. For $n \in \{5, 7, 9, \dots\}$, $K_n^{**} = K_n - \{uv, uw\}$ is \mathbb{Z}_3 -magic.

Proof. Figure 7 illustrates a \mathbb{Z}_3 -magic labeling of K_5^{**} with magic value 1. Using $f_0(x)$ and Theorem 2.1, we see that K_7^{**} has a \mathbb{Z}_3 -magic labeling $\mathcal{L}_{K_7^{**},0}$ with magic value 0. We observe that $K_9^{**} = K_7^{**} + P_2$. Here, let x and y be the vertices of P_2 ; x_1, x_2, \dots, x_7 be the edges joining x to the vertices v_i of K_7^{**} and y_1, y_2, \dots, y_7 be the edges joining y to the vertices v_i of K_7^{**} . Now, consider the following edge labeling of K_9^{**} :

$$\mathcal{L}_{K_9^{**},1}(e_i) = \begin{cases} \mathcal{L}_{K_7^{**},0}(e_i) & \text{if } e_i \in E(K_7^{**}); \\ 2 & \text{otherwise.} \end{cases}$$

This gives a \mathbb{Z}_3 -magic labeling of K_9^{**} with magic value 1. In similar fashion, we can then extend the labeling $\mathcal{L}_{K_9^{**},1}$ to obtain a \mathbb{Z}_3 -magic labeling $\mathcal{L}_{K_{11}^{**},2}$ of K_{11}^{**} with magic value 2:

$$\mathcal{L}_{K_{11}^{**},2}(e_i) = \begin{cases} \mathcal{L}_{K_9^{**},1}(e_i) & \text{if } e_i \in E(K_9^{**}); \\ 2 & \text{otherwise.} \end{cases}$$

Continuing to extend $\mathcal{L}_{K_{11}^{**},2}$, we construct

$$\mathcal{L}_{K_{13}^{**},1}(e_i) = \begin{cases} \mathcal{L}_{K_{11}^{**},2}(e_i) & \text{if } e_i \in E(K_{11}^{**}); \\ 1 & \text{if } e_i = x_1, x_2, \dots, x_{11}, y_1, y_2, \dots, y_{11}; \\ 2 & \text{if } e_i = xy. \end{cases} \tag{1}$$

This gives a \mathbb{Z}_3 -magic labeling of K_{13}^{**} with magic value 1. In similar fashion, we can then extend the labeling $\mathcal{L}_{K_{13}^{**},1}$ to obtain a \mathbb{Z}_3 -magic labeling $\mathcal{L}_{K_{15}^{**},0}$ of K_{15}^{**} with magic value 0:

$$\mathcal{L}_{K_{15}^{**},0}(e_i) = \begin{cases} \mathcal{L}_{K_{13}^{**},1}(e_i) & \text{if } e_i \in E(K_{13}^{**}); \\ 1 & \text{if } e_i = x_1, x_2, \dots, x_{13}, y_1, y_2, \dots, y_{13}; \\ 2 & \text{if } e_i = xy. \end{cases} \tag{2}$$

Extending $\mathcal{L}_{K_{15}^{**},0}$, we construct

$$\mathcal{L}_{K_{17}^{**},2}(e_i) = \begin{cases} \mathcal{L}_{K_{15}^{**},0}(e_i) & \text{if } e_i \in E(K_{15}^{**}); \\ 1 & \text{if } e_i = x_1, x_2, \dots, x_{15}, y_1, y_2, \dots, y_{15}; \\ 2 & \text{if } e_i = xy. \end{cases} \quad (3)$$

This gives a \mathbb{Z}_3 -magic labeling of K_{17}^{**} with magic value 2. From this, we obtain a \mathbb{Z}_3 -magic labeling $\mathcal{L}_{K_{19}^{**},1}$ of K_{19}^{**} with magic value 1. This is accomplished by constructing a labeling of type (1). Using $\mathcal{L}_{K_{19}^{**},1}$, we then obtain a \mathbb{Z}_3 -magic labeling $\mathcal{L}_{K_{21}^{**},0}$ of K_{21}^{**} with magic value 0. This is accomplished by constructing a labeling of type (2). Using $\mathcal{L}_{K_{21}^{**},0}$, we then obtain a \mathbb{Z}_3 -magic labeling $\mathcal{L}_{K_{23}^{**},2}$ of K_{23}^{**} with magic value 2. This is accomplished by constructing a labeling of type (3). Continuing in this manner, \mathbb{Z}_3 -magic labelings are constructed (by “cycling through” type (1), (2) and (3) labelings) for K_{25}^{**} , K_{27}^{**} , K_{29}^{**} , etc. This establishes the claim. \square

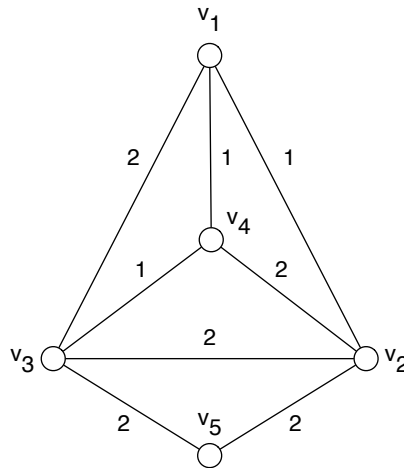

Figure 7: A \mathbb{Z}_3 -magic labeling of $K_5 - \{v_5v_1, v_5v_4\}$ with magic value 1.

Theorem 4.4. For $n \in \{6, 8, 10, \dots\}$, $K_n^{***} = K_n - \{uv, uw, uz\}$ is \mathbb{Z}_3 -magic.

Proof. Figure 8 illustrates a \mathbb{Z}_3 -magic labeling of K_6^{***} with magic value 1. Note that $K_{n+2}^{***} = K_n^{***} + P_2$. Repeated use of Lemma 4.1 establishes the claim. \square

Theorem 4.5. For $n \in \{5, 7, 9, \dots\}$, $K_n^{***} = K_n - \{uv, uw, uz\}$ is \mathbb{Z}_3 -magic.

Proof. Figure 9 illustrates a \mathbb{Z}_3 -magic labeling of K_5^{***} with magic value 1. Using $f_0(\underline{x})$ and Theorem 2.1, we see that K_7^{***} has a \mathbb{Z}_3 -magic labeling $\mathcal{L}_{K_7^{***},0}$ with magic value 0. Using an identical argument (as found in the proof of Theorem 4.3), the claim is established. \square

Here are some results which give constructions of \mathbb{Z}_3 -magic graphs using the join operation.

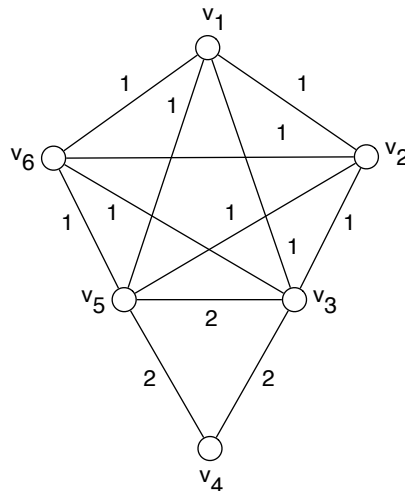

Figure 8: A \mathbb{Z}_3 -magic labeling of $K_6 - \{v_4v_6, v_4v_1, v_4v_2\}$ with magic value 1.

Theorem 4.6. *Let G be a \mathbb{Z}_3 -magic graph (with magic value 1), where $|V(G)|$ is even. Then, $G + P_2 + P_2 + \dots + P_2$ is \mathbb{Z}_3 -magic.*

Proof. This follows immediately from repeated use of Lemma 4.1. □

Theorem 4.7. *Suppose $k \geq 2$. Let G and H_i be \mathbb{Z}_k -magic graphs (with magic value 0), where $|V(G)|$ and $|V(H_i)|$ are even. Then, $G + H_1 + H_2 + \dots + H_l$ is \mathbb{Z}_k -magic.*

Proof. First, we consider $G + H_1$. Let $V(G) = \{v_1, v_2, \dots, v_{2r}\}$ and $V(H_1) = \{w_1, w_2, \dots, w_{2s}\}$. Keeping the \mathbb{Z}_k -magic labelings (with magic value 0) of G and H_1 , we now label the edges v_iw_j (for $1 \leq i \leq 2r$ and $1 \leq j \leq 2s$) in the following way:

$$f(v_iw_j) = \begin{cases} 1 & \text{if } i + j \text{ is even;} \\ k - 1 & \text{otherwise.} \end{cases}$$

This gives a \mathbb{Z}_k -magic labeling of $G + H_1$ with magic value 0. Since $|V(G + H_1)|$ is even, we can proceed in similar fashion to obtain a \mathbb{Z}_k -magic labeling of $(G + H_1) + H_2 = G + H_1 + H_2$, with magic value 0. Iterating this process, the claim is now established. □

Corollary 4.8. *Let G be a \mathbb{Z}_3 -magic graph (with magic value 0), where $|V(G)|$ is even. If H_i are Eulerian graphs where $|V(H_i)|$ and $|E(H_i)|$ are even, then $G + H_1 + H_2 + \dots + H_l$ is \mathbb{Z}_3 -magic.*

Proof. For each H_i , we travel along an Eulerian circuit and label the edges $1, 2, 1, 2, \dots, 1, 2$. Thus, each H_i has a \mathbb{Z}_3 -magic labeling with magic value 0. By Theorem 4.7, the claim is now established. □

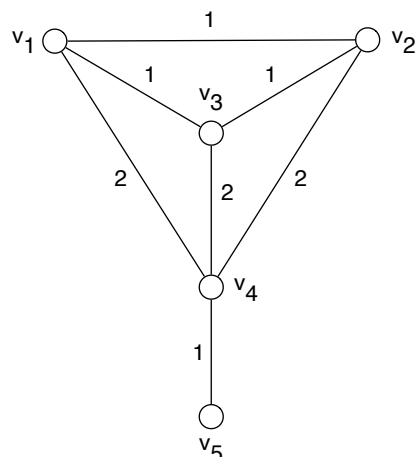

Figure 9: A \mathbb{Z}_3 -magic labeling of $K_5 - \{v_5v_1, v_5v_3, v_5v_2\}$ with magic value 1.

5 Further Directions and some Open Questions

The Combinatorial Nullstellensatz can be generalized in different ways. Theorem 2.1 is true over integral domains. The Generalized Combinatorial Nullstellensatz [14] sharpens Theorem 2.1; instead of analyzing a monomial with degree = $\deg(f)$, it suffices to consider a monomial that does not divide any other monomial term in f . In [10], the author remarks that the Combinatorial Nullstellensatz is true over any commutative ring R with unity, as long as $a - b$ is not a zero divisor in R , for any $a, b \in S_i$ ($i = 1, 2, \dots, m$). Can any of these generalizations of the Combinatorial Nullstellensatz help us in analyzing the \mathbb{Z}_p -magic graph labeling problem (prime $p \geq 3$)?

Another question that we have not yet explored is the *Inverse Problem*. Is it possible to use the f_t polynomials and Theorem 2.1 to generate large classes of \mathbb{Z}_p -magic graphs (prime $p \geq 3$)? One possible approach to tackle this is to write a Mathematica program and have it perform a Monte-Carlo simulation on

- $K_n - \{e_1, e_2\}$, $K_n - \{e_1, e_2, e_3\}$, etc.,
- K_n with a pendant, for $n \geq 6$,
- A highly symmetric graph with an added or deleted edge.

Other open questions include the following:

- Let G be a \mathbb{Z}_p -magic graph, where $|E(G)| \geq \frac{p-1}{p-2} \cdot |V(G)|$. Are there substructures in G which cause the f_t polynomials to not satisfy the hypothesis of Theorem 2.1 (in the context of \mathbb{Z}_p -magic labelings)? See Example 6.
- Are there classes of graphs where the f_t polynomials always satisfy the hypothesis of Theorem 2.1 (in the context of \mathbb{Z}_p -magic labelings)?
- Are there other types of graph labeling problems where the Combinatorial Nullstellensatz can be used?

References

- [1] N. Alon. Combinatorial Nullstellensatz. *Combin. Probab. Comput.*, 8:7-29, 1999.
- [2] J. Gallian. A dynamic survey of graph labeling. *Elect. J. Combin.*, 23:#DS6, 2020.
- [3] F. Harary. *Graph Theory*. Addison-Wesley, Reading, MA, 1994.
- [4] D. Hefetz. Anti-magic graphs via the combinatorial nullstellensatz. *J. Graph Theory*, 50:263-272, 2005.
- [5] T.W. Hungerford. *Algebra*. Springer-Verlag, New York, 1974.
- [6] S. Jukna. *Extremal Combinatorics: With Applications in Computer Science* (second edition). Springer-Verlag Berlin Heidelberg, 2011.
- [7] S-M. Lee, Y-S. Ho and R.M. Low. On the integer-magic spectra of maximal planar and maximal outerplanar graphs. *Congr. Numer.*, 168:83-90, 2004.
- [8] S-M Lee, A. Lee, H. Sun, and I. Wen. On group-magic graphs. *J. Combin. Math. Combin. Comput.*, 38:197-207, 2001.
- [9] R.M. Low and S-M. Lee. On group-magic eulerian graphs. *J. Combin. Math. Combin. Comput.*, 50:141-148, 2004.
- [10] M. Michalek. A short proof of combinatorial Nullstellensatz. *Amer. Math. Monthly*, 117:821-823, 2010.
- [11] J. Przybylo. Neighbour sum distinguishing total colourings via the combinatorial Nullstellensatz. *Discrete Appl. Math.*, 202:163-173, 2016.
- [12] R.C. Read and R.J. Wilson. *An Atlas of Graphs*. Oxford University Press, 1998.
- [13] U. Schauz. A paintability version of the combinatorial Nullstellensatz, and list colorings of k -partite k -uniform hypergraphs. *Electron. J. Combin.*, 17:#176, 2010.
- [14] U. Schauz. Algebraically solved problems: describing polynomials as equivalent to explicit solutions. *Electron. J. Combin.*, 15:#10, 2008.
- [15] W.C. Shiu and R.M. Low. Group-magic labelings of graphs with deleted edges. *Australas. J. Combin.*, 57:3-19, 2013.
- [16] Wolfram Research. *Mathematica* (version 12.1). Champaign, IL, 2020.
- [17] X. Zhu and R. Balakrishnan. *Combinatorial Nullstellensatz with Applications to Graph Colouring*. Chapman and Hall/CRC Press, 2022.