

Geometric and structural information for the analysis of historical domes: the case of SS. Trinità church in Torino

Original

Geometric and structural information for the analysis of historical domes: the case of SS. Trinità church in Torino / DE LUCIA, Giulia; Ceravolo, Rosario. - ELETTRONICO. - (2021), pp. 1996-2006. ((Intervento presentato al convegno 12th International Conference on Structural Analysis of Historical Constructions SAHC 2020 nel 29 Sep - 1 Oct, 2021.

Availability:

This version is available at: 11583/2928776 since: 2021-10-03T16:12:22Z

Publisher:

International Centre for Numerical Methods in Engineering (CIMNE)

Published

DOI:

Terms of use:

openAccess

This article is made available under terms and conditions as specified in the corresponding bibliographic description in the repository

Publisher copyright

(Article begins on next page)

GEOMETRIC AND STRUCTURAL INFORMATION FOR THE ANALYSIS OF HISTORICAL DOMES: THE CASE OF THE SS.TRINITÀ CHURCH IN TORINO

GIULIA DE LUCIA^{1,3*}, ROSARIO CERAVOLO^{2,3}

¹ Interuniversity Department of Regional and Urban Studies and Planning (DIST)
Politecnico di Torino,
Viale Pier Andrea Mattioli, 39 10125 Torino, Italy
e-mail: giulia.delucia@polito.it

² Department of Structural, Geotechnical and Building Engineering (DISEG)
Politecnico di Torino
Corso Duca degli Abruzzi, 24, 10129 Torino, Italy
e-mail: rosario.ceravolo@polito.it

³ Responsible Risk Resilience Interdepartmental Centre (R3C)
Politecnico di Torino
Viale Pier Andrea Mattioli, 39 10125 Torino, Italy
e-mail: r3c@polito.it

Keywords: Masonry domes, FE models, laser scanner survey, SS. Trinità church

Abstract. *Investigation into the geometric configuration of historical masonry domes is fundamental when studying the structural behaviour of these architectural elements, above all if they have historical and artistic relevance. Indeed, accurate geometric information is essential also for the construction of reliable mechanical models, to monitor the condition state of the building and to plan strengthening and conservation interventions. To this aim, a multidisciplinary approach is required to collate the highest possible amount of data useful for the numerical modelling, including historical and archival research.*

The "SS. Trinità" church is a 16th century building of great historical, architectural and structural significance in the historic centre of Turin. It owes its fame primarily to the architect who built it, Ascanio Vitozzi, and to its large dome, built after the architect's death. The availability of a recently undertaken laser scanner survey of the intrados of the dome made it possible to detect several depressions of the masonry cap. These findings can be either due to construction defects, or to structural problems that developed over centuries, or to the severe fire which struck the dome in 1942.

In this multidisciplinary research, different numerical models of the masonry dome of SS.Trinità church were built. As a first step, a geometric study was based on the point cloud from the laser scanning. Then, structural analyses were conducted on the two different models of the dome-tambour system of the building, in order to try to explain the observed deformation behaviour.

1 INTRODUCTION

Digital technologies are increasingly used in the field of three-dimensional geometric data processing because they permit the integration of several kinds of data and numerous measurements. This is particularly important when dealing with the structural analyses of ancient buildings belonging to the architectural heritage, which are often characterized by complex geometric configurations. Indeed, through current laser scanning technologies, it is possible to design accurate geometric models of buildings and structures, facilitating the design of numerical models to be used for the structural analyses.

By simulating the structural behaviour of a building, numerical models are a very useful tool for planning diagnostic surveys, for evaluating the presence of structural damage or seismic vulnerabilities, and for dimensioning and carrying out conservation and retrofitting interventions. Unfortunately, the design of an accurate numerical model is a complex issue because it requires specific information, strictly related to the historical knowledge of the building, which is hard to be collect and interpret. As far as historical buildings are concerned, uncertainties related to the real geometric shape, the construction techniques or the material characterization often limit the accuracy of the models obtained.

This study regards the structural analyses conducted on the SS. Trinità Church in Torino (Fig. 1) in order to investigate the structural behaviour and the structural health conditions of the building, in particular its masonry dome-tambour system. Masonry domes represent an important element of the Italian architectural heritage, but their conservation is a complex issue due to their geometric and structural complexity. For this reason, the use of accurate numerical models able to simulate their global structural behaviour is a precious tool [1][2][3][4][5]. To this aim, a multidisciplinary approach is required to take into account various kinds of data needed for the most accurate possible design of models. The case study presented is a church with a large masonry dome built at the end of the 16th century under commission from the SS.Trinità confraternity. This is located in the historical centre of the city, near the Royal Palace (ducal palace at that time). The project of the church was requested to the architect Ascanio Vitozzi (1539-1615), a member of the confraternity, who greatly influenced the architectural and urban plan of Torino in the early Baroque age. The church was designed using particular geometric rules based on triangles and hexagons, due to their religious symbolism and referring to the church being dedicated to the Most Holy Trinity. It has a central circular plan, with a main altar and two secondary ones. The cylindrical masonry structure is concluded by a massive cornice which support the dome-tambour system, and the church reaches a height of 50 metres [6][7][8].

This work aims to investigate the structural behaviour of the SS.Trinità church through numerical models designed from an accurate initial knowledge of the building and geometric data acquired by traditional and digital survey technologies. In fact, given the lack of specific archive literature (burnt during the 1942 bombardments), the recent laser scans of the church provide accurate geometric data and information on the current state of the structure.

The subsequent structural analyses allow the structural behaviour of the building to be evaluated and also some preliminary assumptions to be made on the possible causes of the deformations.



(a)

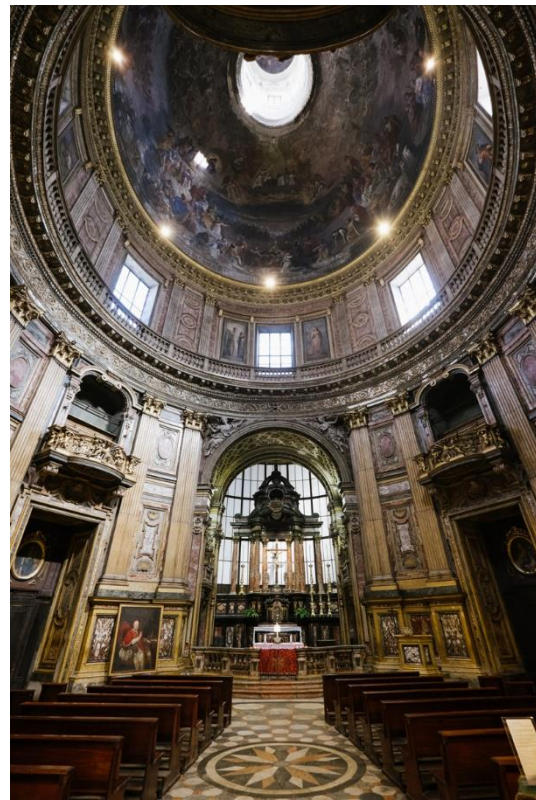

(b)

Figure 1: The SS. Trinità church in Torino: (a) outside view; (b) inside view.

2 THE LASER SCANNER SURVEY OF THE DOME

During the recent restoration work conducted on the church of SS. Trinità, a laser scanner survey of the intrados of the dome was performed. The scanning was conducted using a LEICA BLK360 instrument and the scans were obtained from six measure points with a final resolution of one point for every 5 millimetres. Then, the scans were elaborated as a point cloud. Given access to this point cloud allowed the current shape of the dome to be investigated in this study.

The point cloud was transformed into a mesh, which was the starting point for the design of an accurate geometric model of the dome. The complex geometry of the building and its dome, both in plan and in section, have already been the subject of several geometric studies highlighting the compositional skills of Vitozzi [9]. However, the mesh shows several irregularities and depressions on the intrados of the dome, which are easily visible (Fig.2a). In Figures 2b and 2c, elaborated through 3DReshaper® digital software, the deformations are more evident. They are especially located on the northern side of the dome, to the right of the main altar. For convenience sake, the dome was subdivided in four dials, starting from the main altar, in a clockwise direction. In this scheme, the main deformations are located in the first dial.

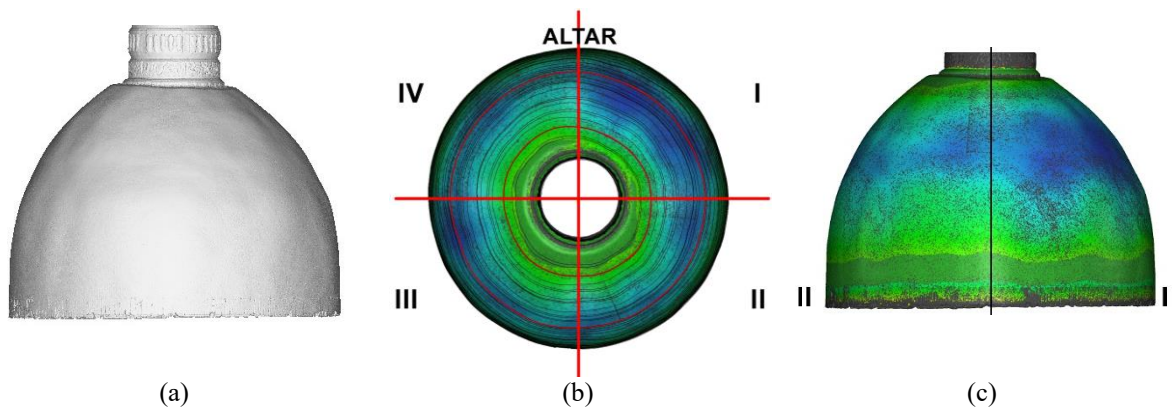

Figure 2: Deformations on the intrados of the dome: (a) the mesh; (b) 3DReshaper elaboration of the deformations, plan view. Red lines indicate the dials subdivision; (c) 3DReshaper elaboration of the deformations. Right front view. In blue the areas with the most marked depressions.

In order to have the most complete knowledge possible of the geometry, data from the mesh were compared and integrated with studies conducted on the only one existing archive drawing of the dome. This drawing is not a project drawing but a traditional geometrical survey conducted in 1792 and takes into account only one half of the dome. This cannot be intended as a design drawing but it can be interpreted as a representation of the initial state of the dome. This comparison was useful in order to quantify the deformations of the dome, by considering section line in the drawing and measuring the discrepancies. The discrepancies reach values of 19 cm in some areas of the intrados (Fig. 3) such as in the fourth section (I-III dials). In the same section, the discrepancies on the other side are 10cm.

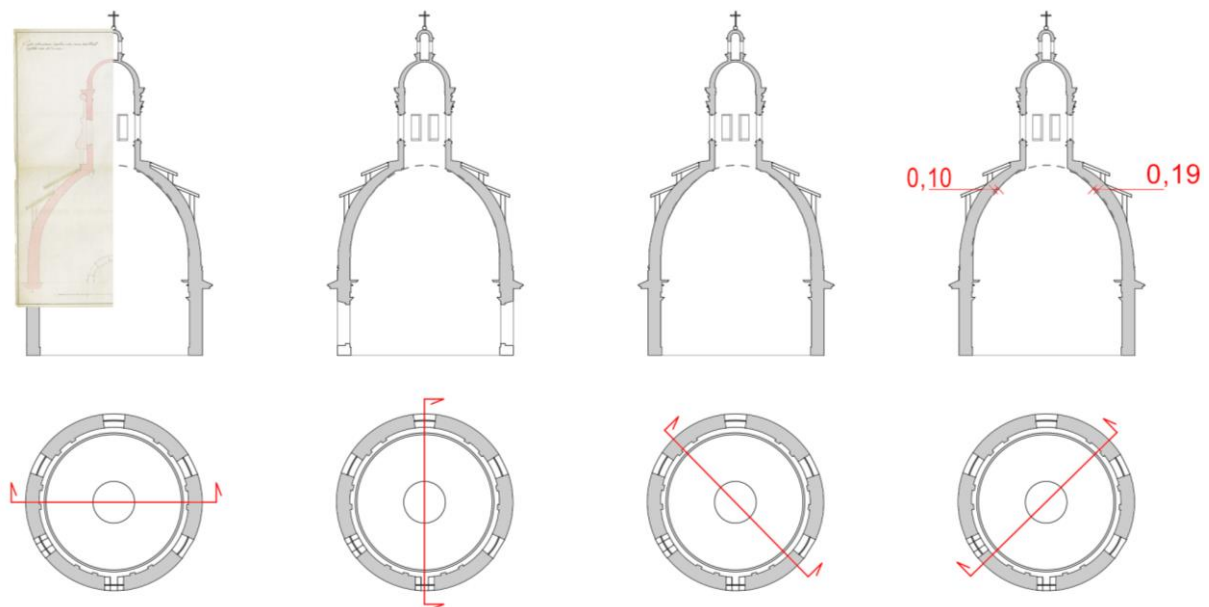

Figure 3: Measuring of the deformations of the intrados in relation to the section line (dropped line). In the first section view, the superposition of the archive drawing can be observed.

3. THE FE MODELS OF THE DOME

In order to investigate the structural behaviour of the dome-tambour system and to increase knowledge about the deformations observed on the first dial the dome, structural analyses on a numerical model had to be carried out. In this study, two different solid element models were used, both built with a macro-modelling approach and the DIANA code.

The first model is an elastic linear model representing an idealised configuration of the dome, without defects or deformations (model-I). The shape of the dome was created with a simple revolution solid of the profile section obtained from the archive drawing. Then, the model was completed with the tambour and the lantern (Fig.4a). The second model reproduces the current configuration of the dome as resulting from the survey (model-R). This model was created by using directly the geometric information obtained from the scans (Fig.4b). Tambour and the lantern were also added to model-R. They were modelled from simple revolution solids, as in the previous case, because the available scans were referred only to the dome area.

It is worth mentioning that, whenever possible, structural analyses of historical domes should be conducted on models that precisely follow the real configuration of the structures. Indeed, for an accurate investigation of the structural behaviour, possible deformations should not be neglected because they can play an important role.

As far as the material characterisation is concerned, historical masonry requires specific knowledge and investigations on their mechanical characteristic, as well as its production and construction techniques. The mechanical parameters of historical masonry should be evaluated through in situ experimental investigations, but such analyses are often too invasive for buildings that belong to the historical architectural heritage. To this regard, data from the literature can usually be used when dealing with preliminary investigations.

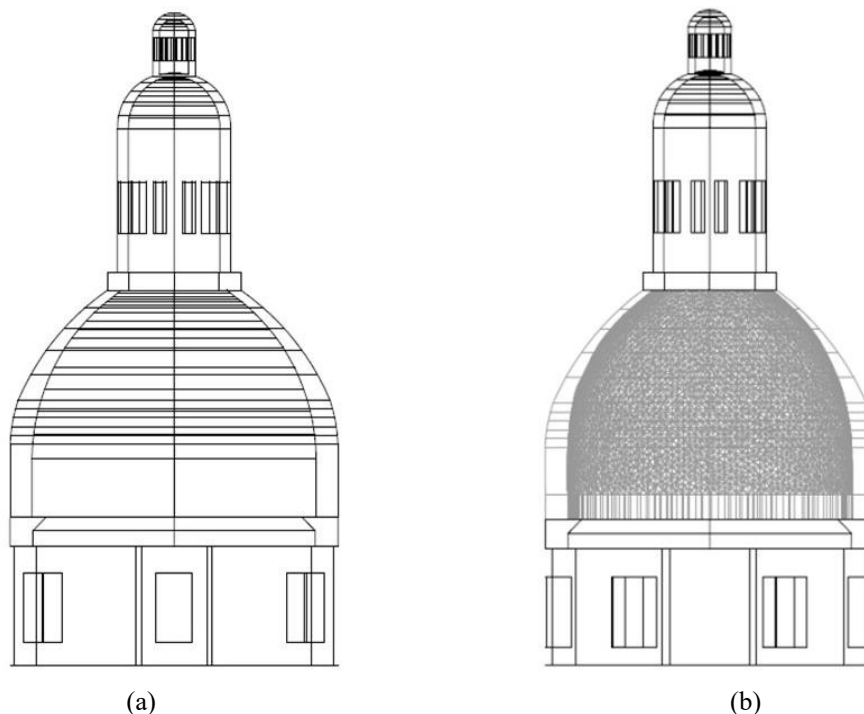

Figure 4: Geometric models of the dome-tambour system of the SS. Trinità Church: (a) model-I; (b) model-R.

In this study, the parameters of the linear model-I were taken from the study by Pistone and Roccati [10], who conducted the material characterization of the masonry of a building in Torino almost contemporary to this case-study. For the non-linear model-R, a standard elastoplastic model based on the Drucker-Prager (DP) criterion was used, considering the masonry as a material with isotropic behaviour and plastic deformations [11]. Even in this case, data about the elastic phase and resistance of the masonry were taken from the literature [12]. Table 1 shows the mechanical parameters used for the two models.

Then, vertical loads and the snow load were applied to the dome, in addition to the punctual loads related to the two roofs placed on the extrados of the dome. Both models were constrained at the base of the tambour assuming the rest of the building as very stiff.

Table 1: Mechanical parameters used for the masonry of the SS.Trinità church

E [MPa]	ν [-]	γ [kN/m ³]	c [MPa]	φ [°]	δ [°]	f_c [MPa]	f_t [MPa]
1750	0.25	18	0.24	38	15	4.36	0.24

4. THE STATIC ANALYSES

Static analyses were conducted with the aim of obtaining information about the global structural behaviour of the dome-tambour system and in order to investigate the possible causes of the appearance of the deformations and their influence on the structural state of the building. In fact, the deformations could be due to construction defects and imperfections, to structural problems which appeared over time, or to the severe fire experienced by the dome in 1942. It is important to note that investigations in this field is also deemed to contribute to the historical critical debate. Indeed, some questions about the paternity of the dome, built after Vitozzi's death, still remain unanswered, while doubts remains that the current shape of the dome is that designed by Vitozzi, considering the absence of project drawings [9]. This highlights the importance of a multidisciplinary approach, necessary when dealing with cultural heritage architecture.

Although the assumption of an elastic behaviour for the masonry does not correspond to its real behaviour, such a basic model can be useful in a preliminary stage because it sheds some light on the stress distribution and the displacements affecting the dome. The results of the linear analyses conducted on model-I, and the non-linear analyses conducted on model-R are reported in terms of vertical stress and displacements.

According to both models, the stress state due to the constant vertical loads is moderate: the average compression stress on the extrados of the dome is 1.7 N / mm² for the non-linear model and 0.9 N / mm² for the linear model. These are expected values in domes and confirm that the structure is able to support the loads to which it is subjected. As far as the representation of the vertical stress is concerned, a horizontal band distribution is visible in linear model-I (Fig. 5a). However, of greater interest is the distribution of the stress state on non-linear model-R. In fact, positive values of stress at the top of the lantern and at the central horizontal band of the dome can be noted, as well as a gradient in the area of the first dial (Fig. 5b). This behaviour is related to the non-linearity of the model which takes into account the real geometry of the dome.

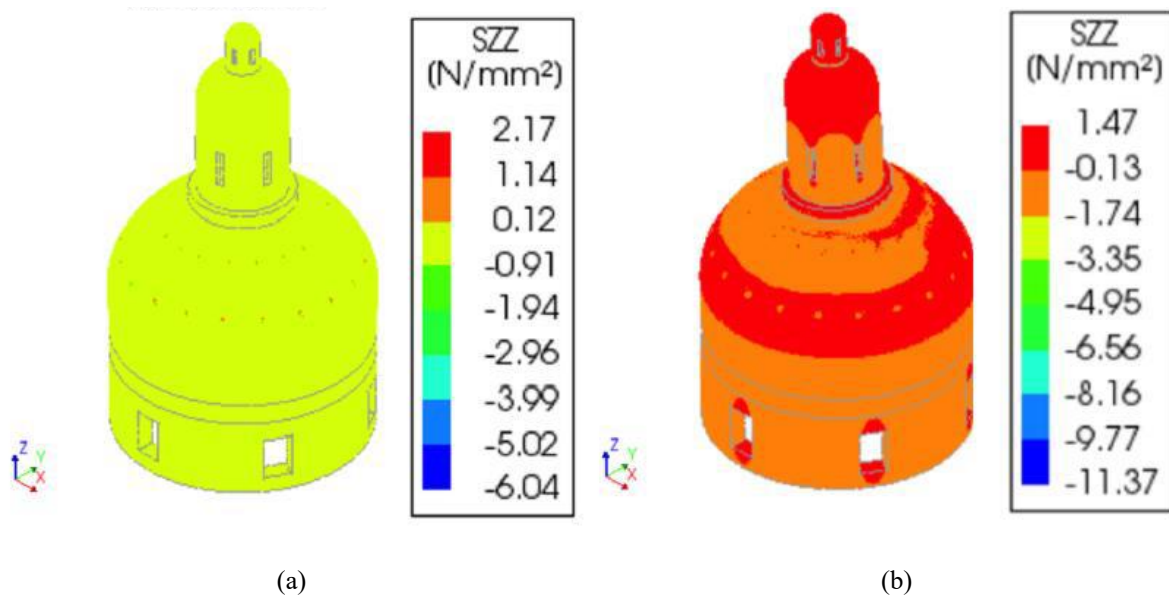

Figure 5: Representation of the vertical stress: (a) linear model-I; (b) non-linear model-R.

It is also interesting to observe the results of the analyses in terms of vertical displacements. For model-I the vertical displacements obviously have a homogeneous distribution along the parallel of the dome, but for model-R the structural deformations cause an asymmetric displacement field. In particular, higher displacements can be observed at the base of the lantern in the third dial, exactly on the opposite side to the area with the main deformations, to which the eccentricity of the lantern seems to correspond. The effect of this eccentricity is a compression increment at the base of the dome on the third dial and a decompression increment on the first dial. The decompression results in greater inflexion values on the first dial area measured at the same height levels, in particular on the area affected by the largest deformations. This effect is clearly observed in Figure 6.

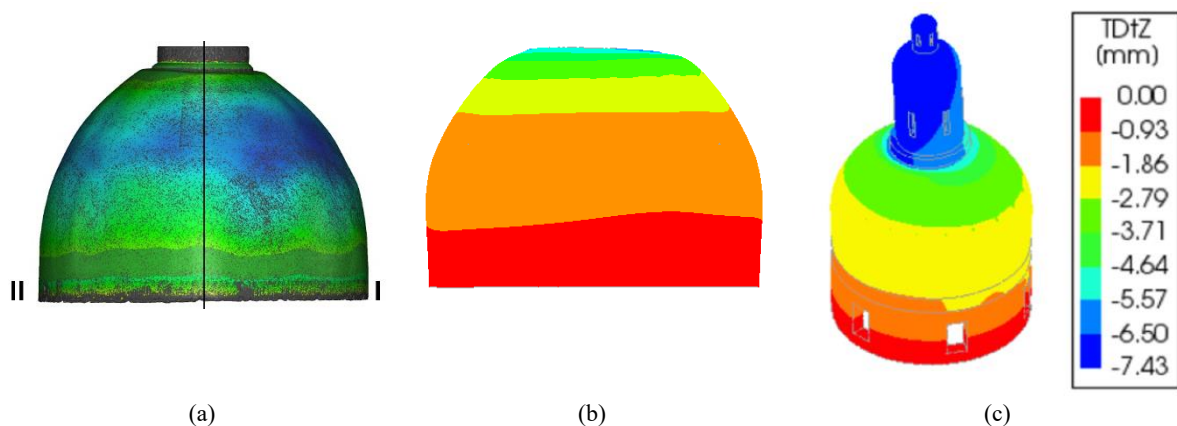

Figure 6: (a) representation of the structural deformations on the dome; results of the non-linear analysis in terms of vertical displacements: (b) front view; (c) axonometric view.

From the plan view, in Figure 7, it is possible to notice the high level of vertical displacements at the base of the lantern on the third dial. This configuration is totally in agreement with what was observed in the scans, where it is easy to note a lateral lowering of the lantern.

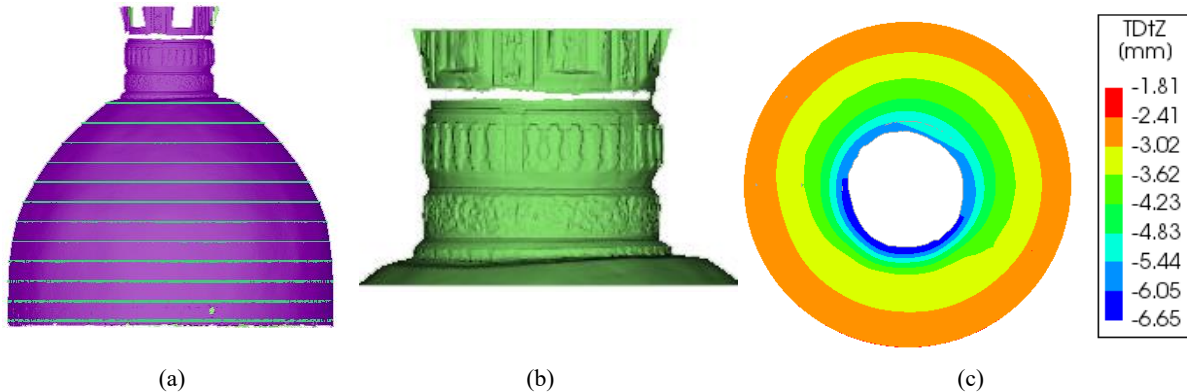

Figure 7: Deformations on the intrados of the dome: (a) the mesh; (b) zoom of the lantern area; (c) results of the non-linear analysis in terms of vertical displacements, top view.

In order to examine in depth the displacement trends by analysing both the internal and external surfaces of the dome, five reference heights were defined, each of which at a relevant increment of displacement value. Then, the vertical displacement and stress values on the nodes located at the intrados and the extrados of the dome were obtained. The detail in Figure 8 shows that, in the area between a height of 17 and 21 metres (measured from the impost of the tambour), the displacement values for both intrados and extrados increase with the increasing height. As far as the vertical stress is concerned, the values measured on the extrados follow the same trend while in contrast they decrease on the intrados.

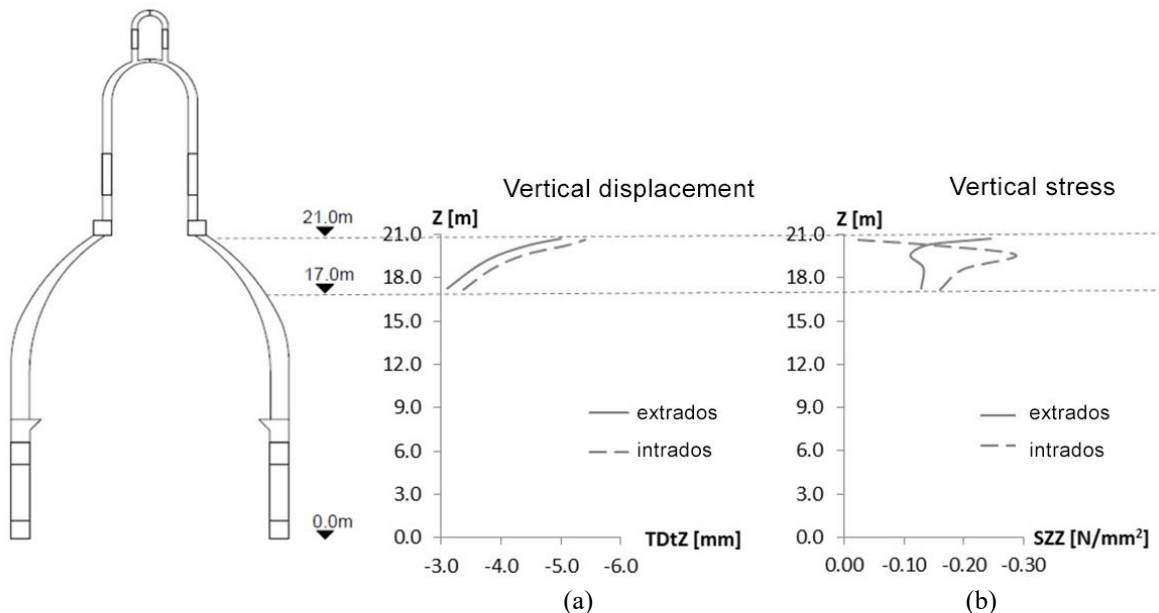

Figure 7: Values of vertical displacement (a) and vertical stress (b) for the nodes of the both extrados and intrados in the area of the dome considered between a height of 17 and 21 metres.

4.1 Viscoelastic behaviour of the dome

Simplified viscoelastic analyses (creep) were conducted in order to investigate whether a possible cause of the depressions observed around the dome can be related to the viscous long-term behaviour of masonry.

The method used for plotting long-term displacement curves was taken from the literature [13], assuming the mortar be the viscous phase of the masonry material. The data on the mortar came from constant compression tests reported in the literature [14]. However, the use of a single trend of a mortar test was not sufficient to estimate the viscous behaviour of the masonry. Consequently, a physical model, able to simulate the global behaviour of the material, was deemed necessary.

By setting the viscous phase vs. elastic phase ratio equal to 1:4, the creep function of masonry was obtained. Hence the deformation was calculated accordingly, as a function of the stress history. In order to observe the creep effects on the masonry, the study of the load effect over time in different temporal steps is required. In Figure 9 the evolution over time of the vertical displacement values is shown. They start from a value of shortening equal to 7.6 mm for the first out of 15 steps in a 55-year period, to reach a maximum value of 20.2 mm for the last temporal step.

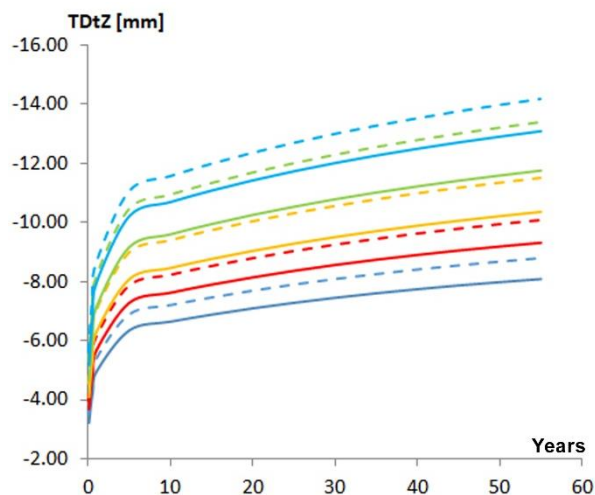

Figure 9: (a) the Vertical displacements over time for the extrados (continuous line) and the intrados (dotted line). The value are measured at five height points (17.2 meters: blue line; 18.7m red line; 19.6 m yellow line; 20.3m green line; 20.7 light blue line).

The model confirms the first dial of the dome to be the more affected by viscous phenomena, in accordance with the observation. In Figure 10, the vertical displacement values are plotted as a function of time, extending the creep analysis to a period of 400 years (approximately the age of the dome). While the deformations measured by the laser scanner survey are in accordance with the elastic and viscoelastic deformations obtained from the creep analyses, these results represent a qualitative value awaiting more in-depth investigations, also due the lack of accurate data on the materials.

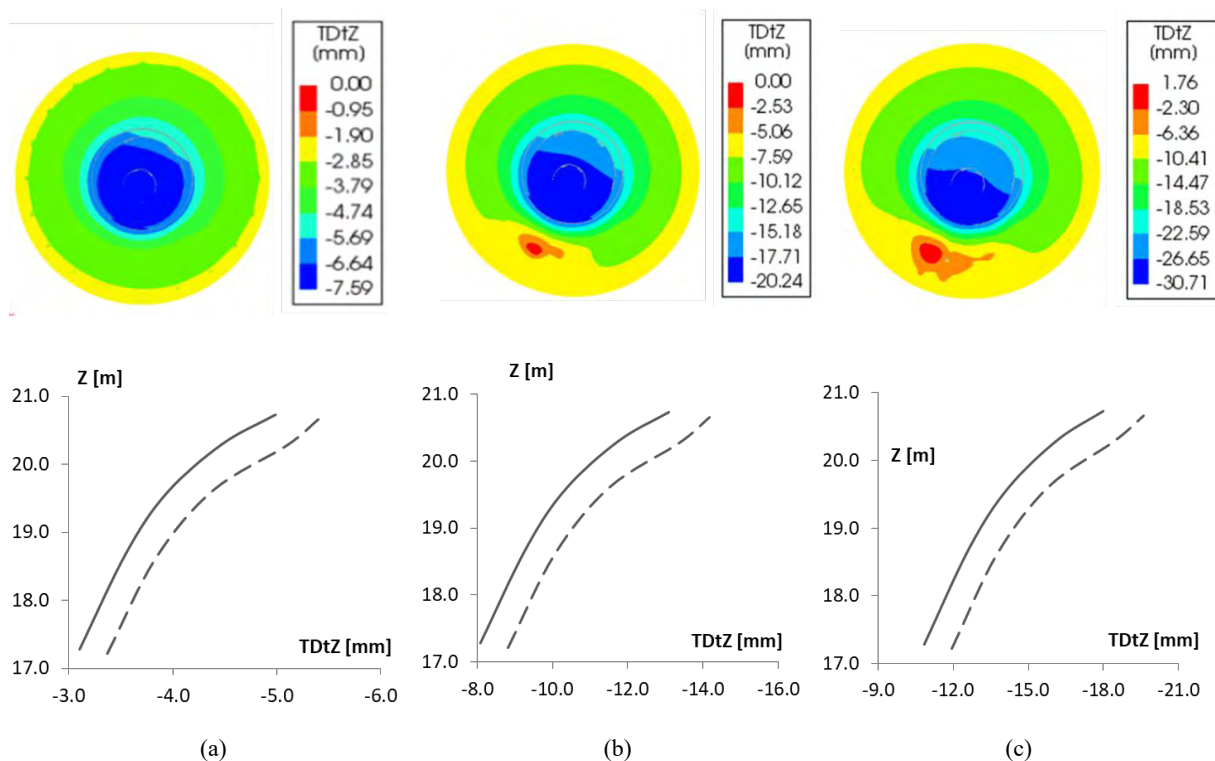

Figure 9: Vertical displacement values as a function of time : (a) 30 days; (b) 55 years; (c) 400 years.

CONCLUSIONS

This study investigated the potentialities of using accurate geometric survey data for the structural analysis of buildings belonging to historical architectural heritage and characterized by complex geometric configuration.

The geometry of the large dome of the SS.Trinità church in Torino was the starting point for creating a realistic mechanical model of the dome-tambour system. Finite element models confirm that geometric deformations observed on the dome are not alarming for the current structural health of the building. Moreover, it was observed that the depressions, possibly due to the construction defects and imperfections can have an important influence on the stress and deformation state of the dome, importantly affecting the global behaviour of the structure. Moreover, creep analyses demonstrated that also viscous deformations can play a role in the static configuration and consequent anomalies. In this specific case, the numerical model showed that the observed leaning of the lantern system, as evidenced by the digital survey, can be the cause of a decompression on a side of the dome, and the consequent depressions in the intrados. Although this research represents only a preliminary study, the results can still support some qualitative, but useful, structural engineering evaluations. It might as well help historians finally resolve the controversy on paternity of this dome, which has long been committed the scientific community. Future studies will address the influence of the fire caused by the World War II events.

REFERENCES

- [1] De Lucia, G., Ceravolo, R., Chiorino, M.A., Miraglia G., *The role of structural health monitoring in the seismic protection of monumental structures: the virtual lab of the sanctuary of Vicoforte*, proceeding of VII Structural World Engineering Congress, Istanbul, 24-26 Aprile (2019).
- [2] Como, M., *Statica delle costruzioni storiche in muratura*, Rome, Italy, Aracne Editrice, (2010).
- [3] Ottoni F., Dome Strengthening By Encircling Ties: A Monitored Experiment, *Int J Archit Herit.* (2015), **9**:82-95.
- [4] Ottoni, F., Blasi C., Hooping as an ancient remedy for conservation of large masonry domes, *Int. J. Archit. Herit.*, (2015), **10**:164-181.
- [5] Cavalagli N. & Gusella V., Dome of the Basilica of Santa Maria degli Angeli in Assisi: Static and Dynamic Assesement, *Int J Archit Herit* (2015), **9**: 157-175.
- [6] Scotti, A., *Ascanio Vitozzi. Ingegnere ducale a Torino*, La nuova Italia Editrice, Firenze, (1969), p. 18.
- [7] Viglino Davico, M., La chiesa della Santissima Trinità. In Viglino Davico, Ascanio Vitozzi. *Ingegnere militare, urbanista, architetto (1539-1615)*, Quattroemme, Perugia (2003), pp. 231-242.
- [8] Ruffino, M. (Eds): *Una chiesa per il Ducato, la Ss. Trinità di Torino*, Torino, CLUT, (2019).
- [9] De Lucia, G., Lenticchia E., Ceravolo R., La geometria della cupola della SS.Trinità: dal dato metrico alle valutazioni strutturali, In Ruffino, M. (Eds): *Una chiesa per il Ducato, la Ss. Trinità di Torino*, Torino, CLUT, (2019), pp. 117-142.
- [10] Pistone G. and Roccati R., *Testing of large undistributed sample of old masonry*. In Proceeding of the 8th International Brick/Block Masonry Conference, Dublin, 19-21 September (1988).
- [11] Drucker D. and Prager W., Soil mechanism and plastic analysis or limit design, *Quarterly of Applied Mathematics*, (1952), **10**:157-165.
- [12] Betti, M., Galano, L., Vingoli A., Finite element modelling for seismic assessment of historical masonry buildings. In: D'Amico, S. (Eds), *Earthquakes and their impact on society*, Springer, Switzerland, (2016), pp. 377-413.
- [13] Spina, A., *Analisi degli effetti del comportamento a breve e lungo termine di torri in muratura: il caso della torre campanaria del Duomo di Torino*. Thesis in Civil Engineering, Politecnico di Torino, 2018.
- [14] Cominelli S., *Comportamento delle murature storiche al collasso: meccanismi di rottura, effetti del confinamento e fenomeni reologici*. PhD Thesis, Università degli studi di Brescia, 2014.