

New concepts for light mechanical structures of cylindrical drift chambers

Original

New concepts for light mechanical structures of cylindrical drift chambers / Chiarello, G.; Cuna, F.; Grancagnolo, F.; Miccoli, A.; Panareo, M.; Tassielli, F. Rossetti(G. F.; Zavarise, G.. - ELETTRONICO. - (2020). ((Intervento presentato al convegno Instrumentation for Colliding Beam Physics (INSTR-20) tenutosi a Novosibirsk, Russia nel 24-28 febbraio 2020.

Availability:

This version is available at: 11583/2917292 since: 2021-08-06T00:04:42Z

Publisher:

Conference Organization

Published

DOI:

Terms of use:

openAccess

This article is made available under terms and conditions as specified in the corresponding bibliographic description in the repository

Publisher copyright

(Article begins on next page)

NEW CONCEPTS FOR LIGHT MECHANICAL STRUCTURES OF CYLINDRICAL DRIFT CHAMBERS



G. Chiarello^(b), F. Cuna^(a), F. Grancagnolo^(b), A. Miccoli^(b), M. Panareo^(a), F. Rossetti^(c), G. F. Tassielli^(b), G. Zavarise^(d)

(a) Dipartimento di Matematica e Fisica, Università del Salento, Italy; (b) Istituto Nazionale di Fisica Nucleare, Italy; (c) EnginSoft, Italy; (d) Politecnico di Torino, Italy.



ABSTRACT

A significant reduction in the amount of material at the end plates of a drift chamber can be obtained by the simple consideration of separating, in the mechanical structure, the gas containment function from the wire tension support function. According to this scheme, the wires are anchored to a self-sustaining light structure ("wire cage") surrounded by a very thin skin ("gas envelope") of suitable profile to compensate for the gas differential pressure with respect to the outside. The "wire cage" is schematically made of a set of radial spokes, constrained into a polygonal shape at the inner ends and extended to the outer endplate rim, thus subdividing the chamber in identical sectors. The drift chamber is, then, built by stacking up radially, in each of the sectors and between adjacent spokes, printed circuit boards, where the ends of the wires are soldered, alternated with proper spacers, to define the cell width. A system of adjustable tie-rods steers the wire tension to the outer endplate rim, where a rigid cylindrical carbon fibre support structure, bearing the total wire load, is attached. Two thin carbon fibre domes, free to deform under the gas pressure without affecting the wire tension and conveniently shaped to minimize the stress at the inner rim, contribute to the "gas envelope" and, together with an inner thin cylindrical foil and with the outer structural support, enclose the gas volume.

SEPARATION OF FUNCTIONS

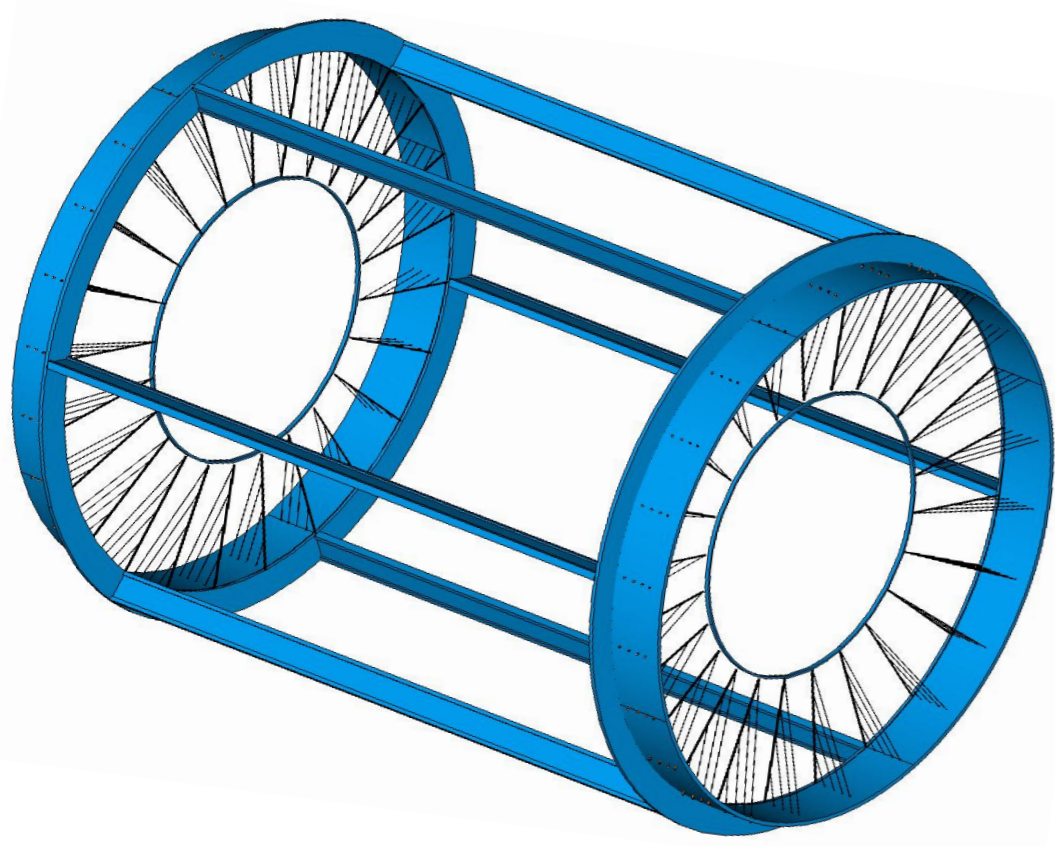

Wire support:

Wire cage structure not subject to differential pressure can be light and feed-through-less.

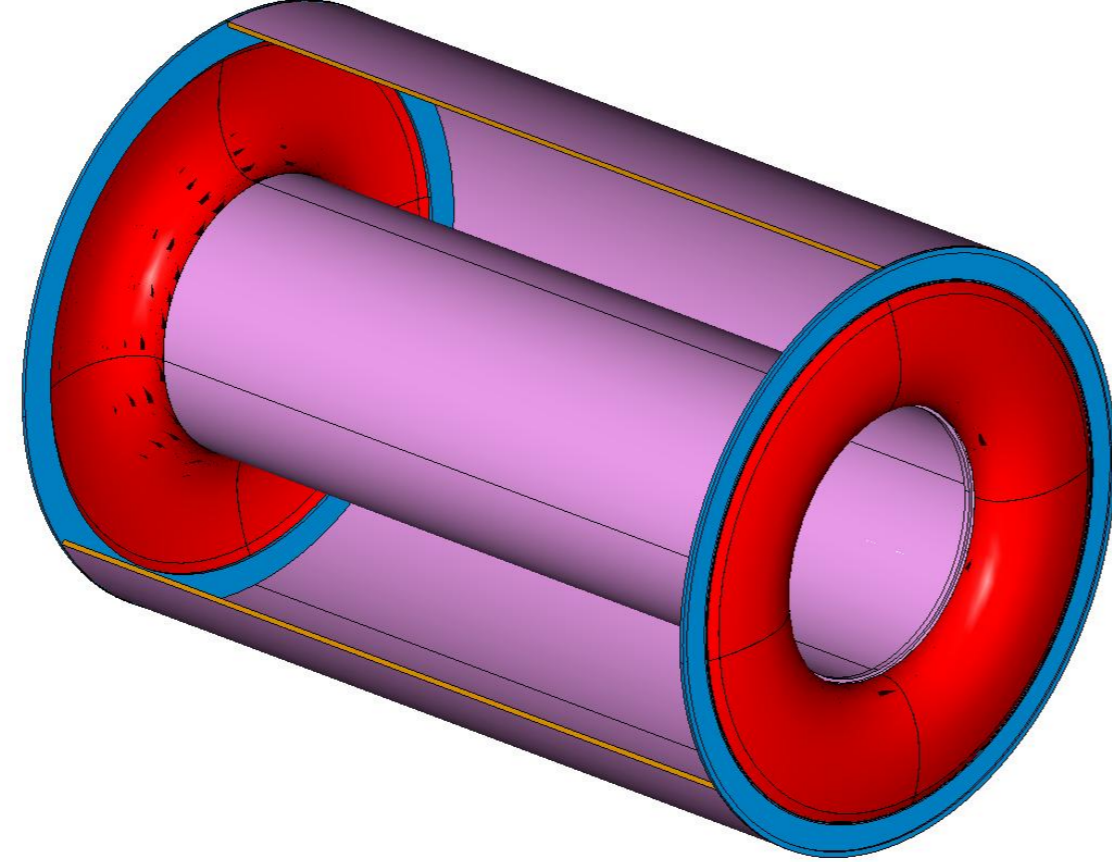

Gas containment:

Gas envelope can freely deform without affecting the internal wire position and tension.

A significant reduction in the amount of material at the end plates can be obtained by the simple consideration of separating, in the mechanical structure, the gas containment function from the wire tension support function. According to this scheme, the wires are anchored to a self-sustaining light structure ("wire cage") surrounded by a very thin skin ("gas envelope") of suitable profile to compensate for the gas differential pressure with respect to the outside. The "wire cage" is schematically made of a set of radial spokes, constrained into a polygonal shape at the inner ends and extended to the outer endplate rim, thus subdividing the chamber in identical sectors.

WIRE CAGE

Layer buildup: stratigraphy

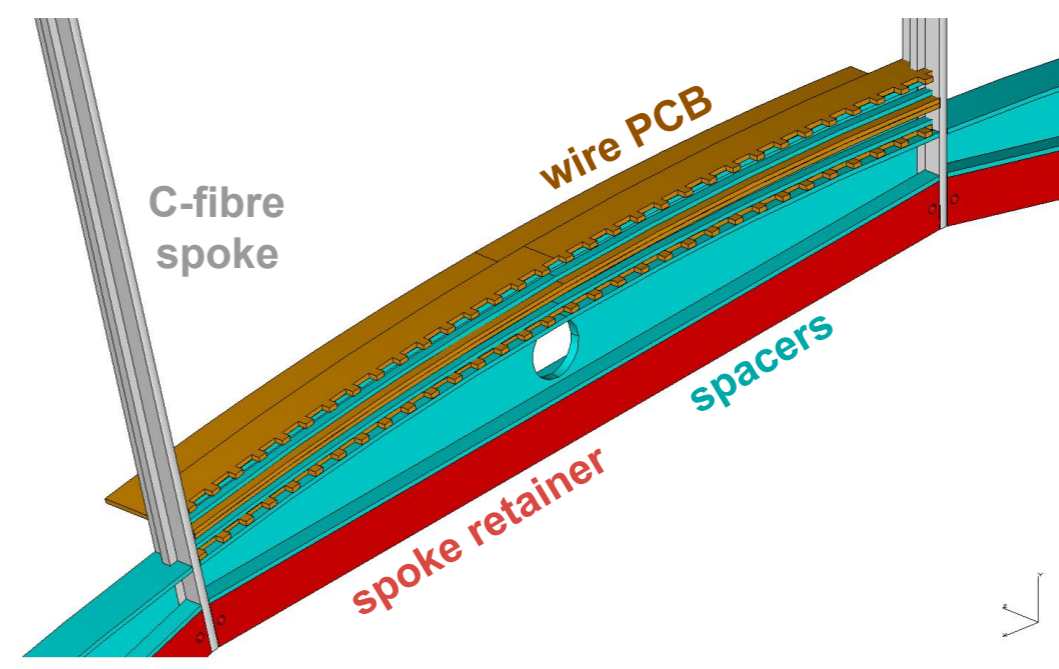

Stereo angle development

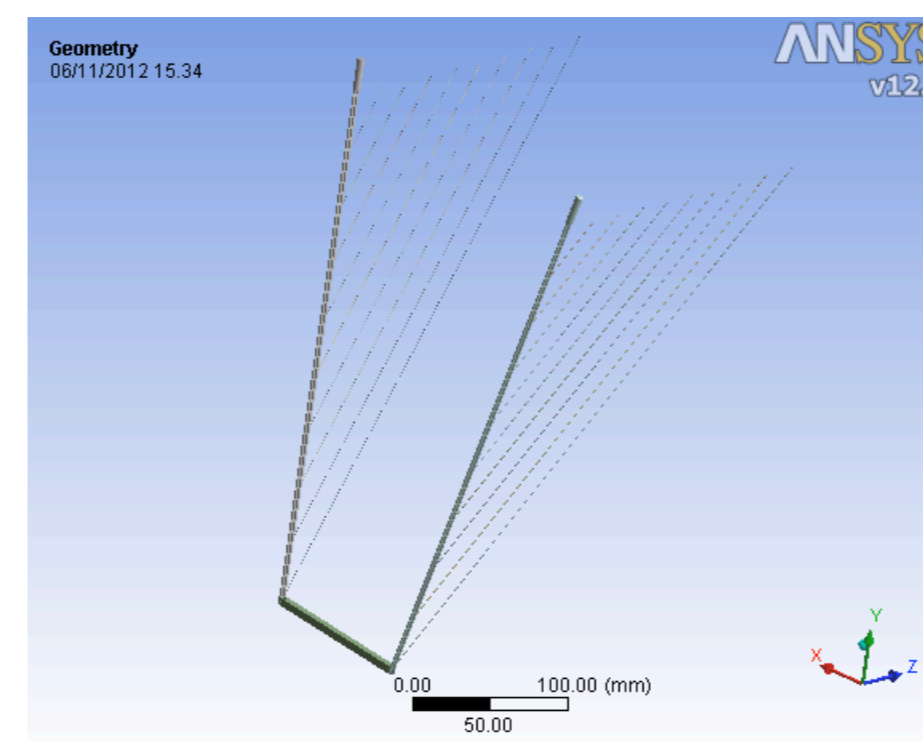
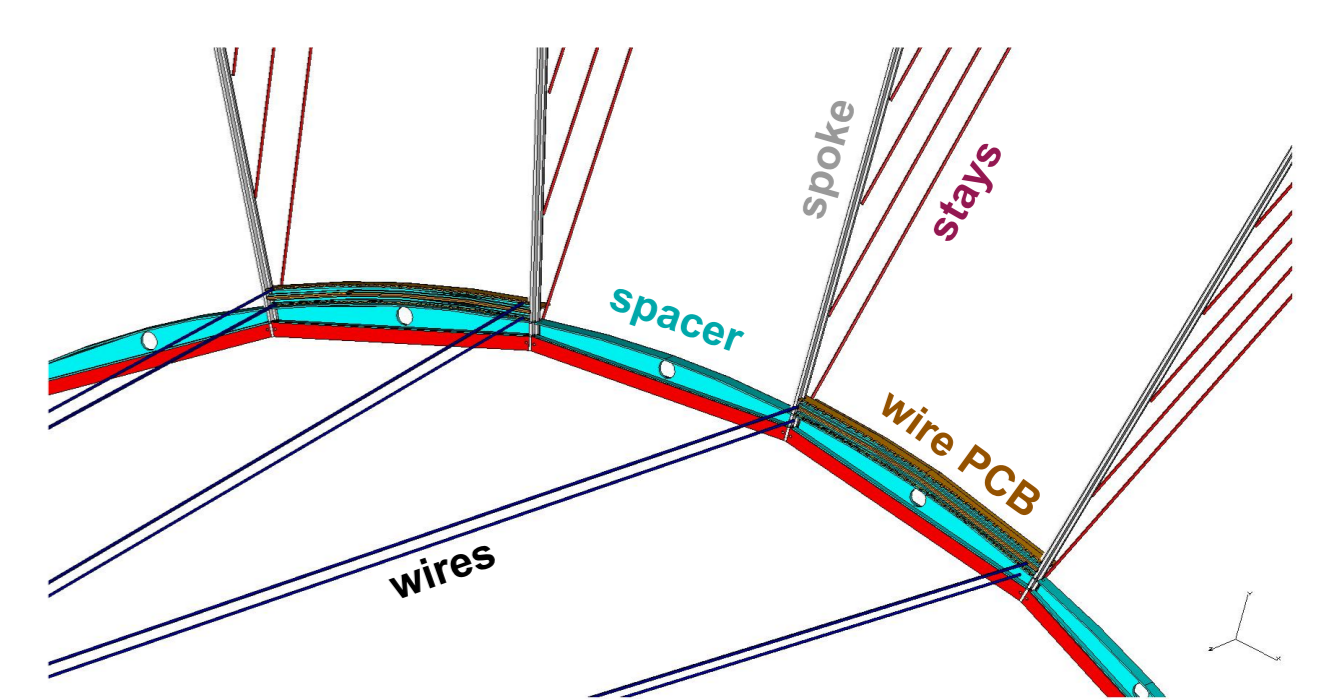

Each **spoke** is under tension against the structural outer cylinder shell. This tension is transferred to the **spoke retainers**, which are all constrained by their polygonal structure. The distribution on the spokes of the load due to the wire tension per unit length is a function of the number of layers (36 here), the number of cells per sector (16) and the number of sectors (24). Assuming 1 cm² average size cells and 150 g (5 field wires per sense wire) tension per cell, each spoke feels a flexural stress of 60 Kg (1.5 Kg/cm) which must be compensated by the tension applied to the **stays**. Assuming one stay every 4 layers, 9 stays total, the tension to be applied to each stay amounts to less than 20 Kg. This amounts to a maximum local transverse deviation along each spoke of less than **10 μm**.

GAS ENVELOPE

End-plate profile optimization by multivariate analysis

- Use isotropic material (1 mm thick Aluminum) solid rotational plates + inner cylinder (ideal joints)
- Assume infinitely rigid outer cylinder
- Parameterize geometry by:
 - constraining **inner cylinder radius**
 - constraining **inner cylinder length**
 - constraining **outer cylinder radius**
 - varying middle point of a **3 point-spline profile** for the end plates
- Optimize dynamic properties:
 - **minimum stress at inner boundary**
 - **minimum of maximum stress**
 - **maximum safety factor**
- **No convergence for isotropic material**
- Replace isotropic material with light composite material

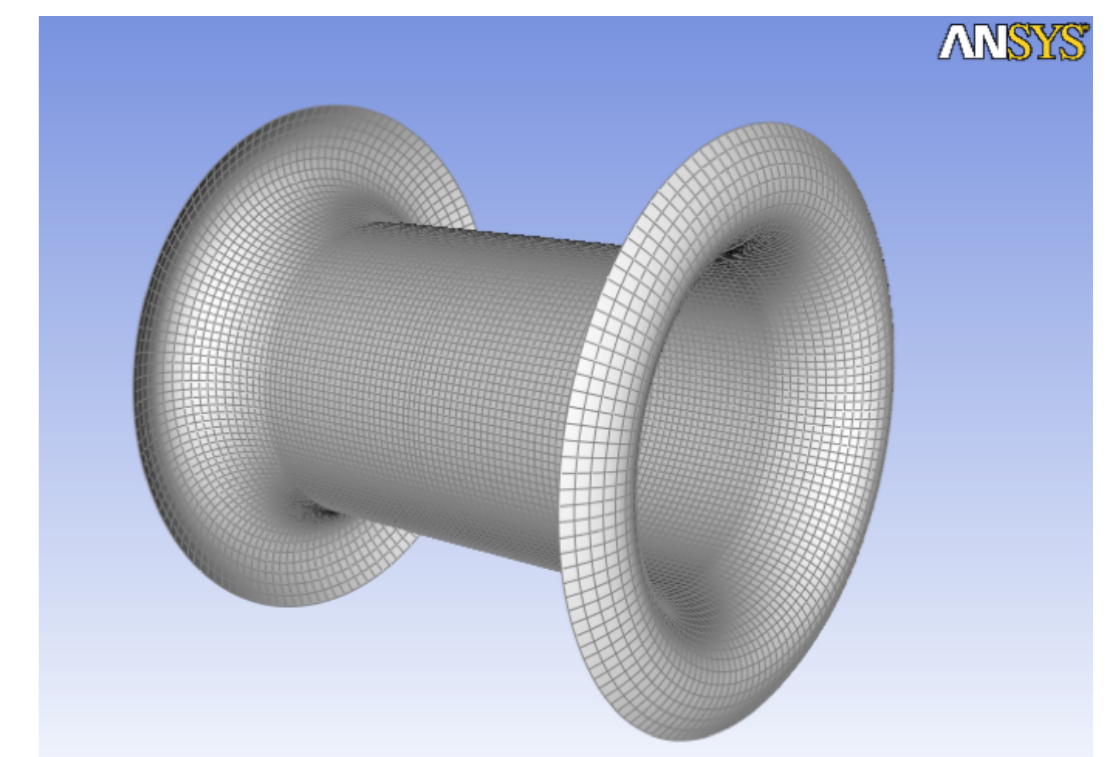
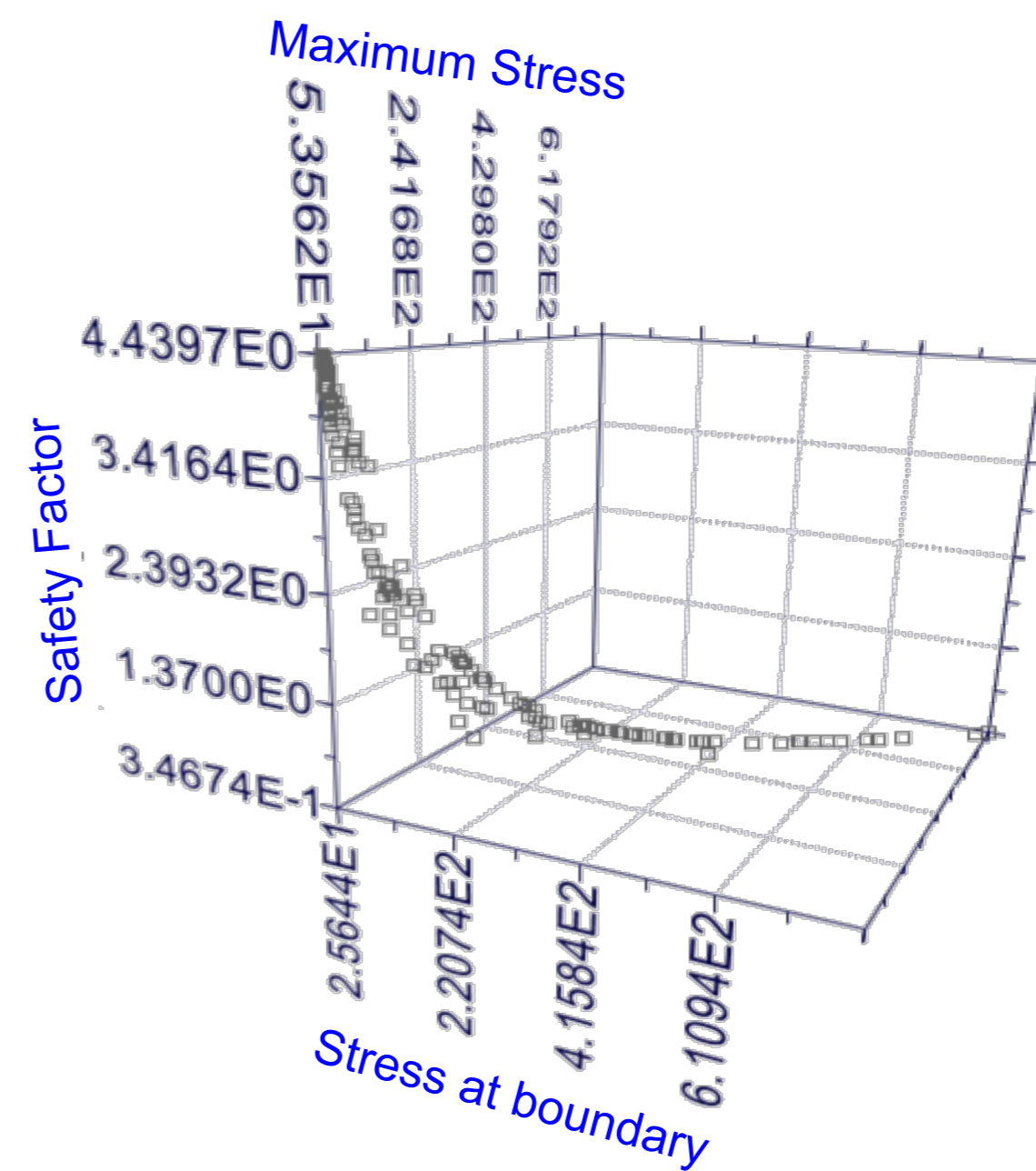

parameters	Initial model	Optimized model
Maximum stress	357.5 MPa	58.7 MPa
Stress at inner boundary	267.4 MPa	26.6 MPa
Safety factor	0.783	4.44

Replace isotropic material with composite material

- Chose proper unidirectional prepreg and form ply
- Check for feasibility of the chosen geometry
- Draping of the laminates and flat-wrap of the model (align the fibers along the direction of stress)
- Static structural analysis for different configurations and different choices of prepreg

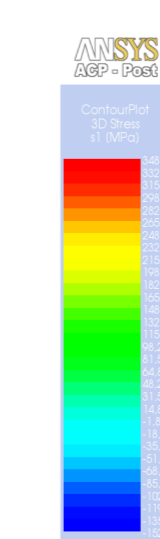
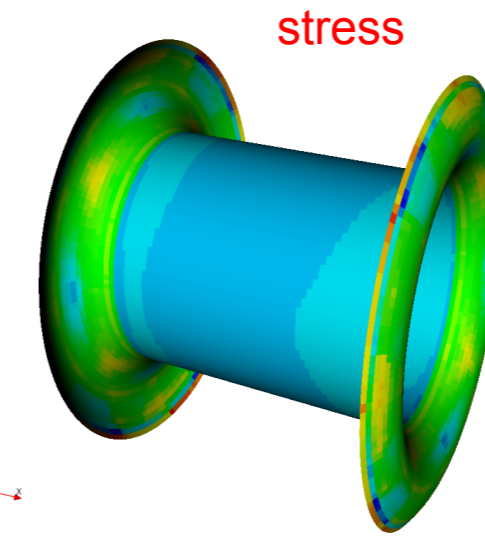
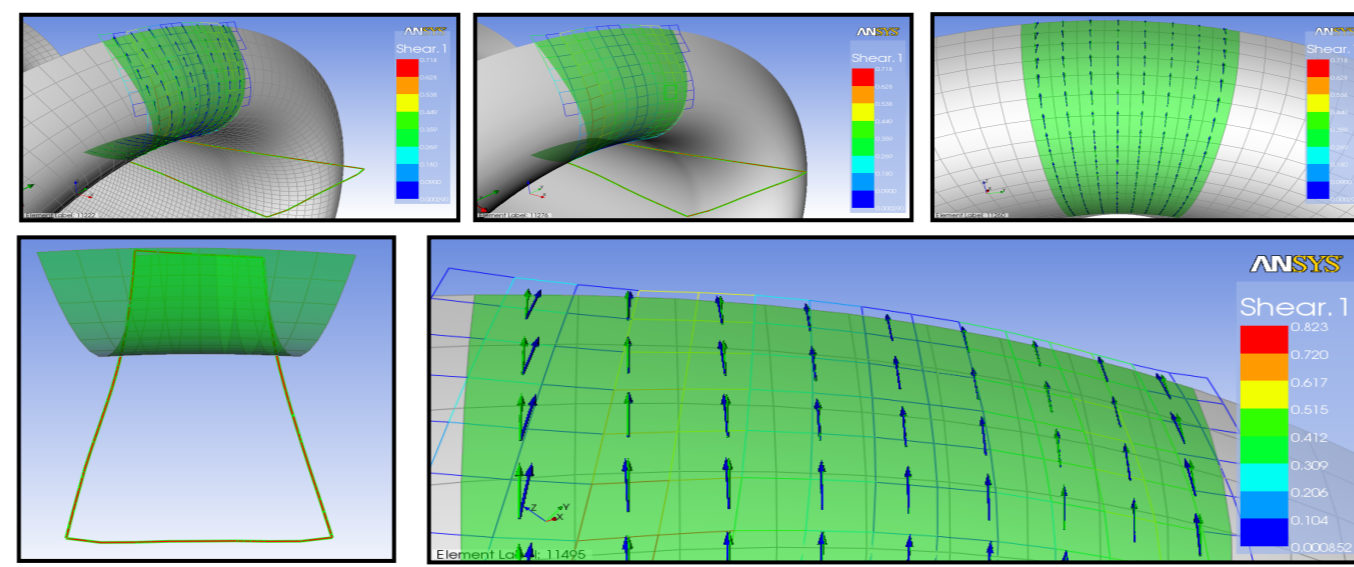

Static solution with 4-ply Orthotropic (0-90-90-0) HM M30S 53 ET443 51% 60 μm/ply - 0.0053 g/cm² but Inner cylinder unstable for buckling unless ...

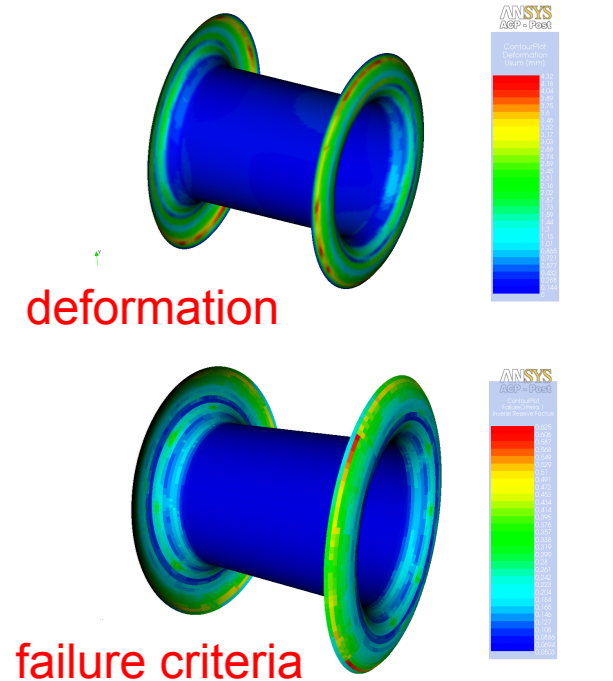

Solve buckling instabilities

- Case of isotropic 1 mm Al:

critical load / applied load = load multiplier = 0.092 !

Critical load proportional to cylinder moment of inertia proportional to **thickness⁴**

Solution is sandwich of 2 C-fiber skins, 2-ply each, HM M30S 53 ET443 51% with a 4.76 mm C-foam core Grafoam® FPA-10 for a total areal mass of **0.100 g/cm² total**

load multiplier = 2.4

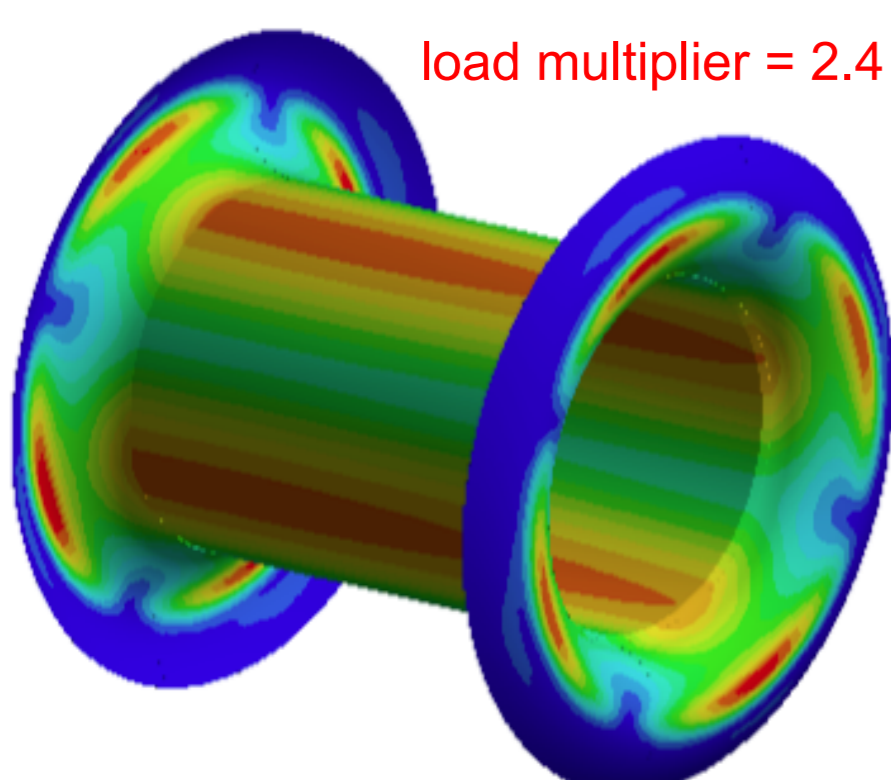

Inner cylinder sandwich: 2 C-fiber skins, 2-ply each, HM M30S 53 ET443 51% + C-foam core, 5 mm total Grafoam® FPA-10 **0.100 g/cm² total**

End plates: 4-ply orthotropic (0-90-90-0) HM M30S 53 ET443 51% 60 μm/ply - 0.0053 g/cm² **0.021 g/cm² total**

MATERIAL BUDGET

WIRE CAGE				GAS ENVELOPE			
	[g/cm ²]	X ₀ [10 ⁻³]	Hit probability	[g/cm ²]	X ₀ [10 ⁻³]		
Spokes	0.397	9.30	0.0225	0.009	0.2	0.011	1.95
Stays	0.009	0.19	0.00775				
Spokes connecting ring	0.850	19.9	0.023	0.019	0.5	0.079	4.50
Spacers	0.074	1.80	0.878	0.065	1.6	0.011	
field wires board	0.720	2.64	0.05	0.036	1.3	1.700	39.81
sense wire board	1.800	6.59	0.024	0.045	1.6	0.040	0.92
R/O board components				0.027	1.2		0.10
HV board components				0.047	2.0		
R/O cables				0.001	0.0		
HV cables				0.019	1.2		

		Wire Cage		Gas Envelope		TOTAL	
		[g/cm ²]	X ₀ [10 ⁻³]	[g/cm ²]	X ₀ [10 ⁻³]	[g/cm ²]	X ₀ [10 ⁻³]
Upstream End-Plate	Spokes + Stays	0.009	0.2	0.021	0.4	0.203	6.3
	Spacers	0.065	1.6				
	Wires board	0.081	2.9				
	R/O components	0.027	1.2				
Downstream End-Plate	Total above	0.182	5.9	0.021	0.4	0.297	10.7
	R/O + HV comp.	0.074	3.2				
	R/O + HV cables	0.020	1.2				
Inner Cylinder	Connecting rings			0.107	2.5	0.208	4.4
	Sandwich			0.101	1.9		

Work originally developed for the I-tracker drift chamber proposed for the Mu2e experiment at Fermilab