

Towards a PHM system for Electro-Mechanical Flight Control Actuators

Original

Towards a PHM system for Electro-Mechanical Flight Control Actuators / Bertolino, Antonio Carlo; De Martin, Andrea; Jacazio, Giovanni; Sorli, Massimo. - ELETTRONICO. - (2020). ((Intervento presentato al convegno I-RIM 3D 2020 nel 10-12/12/2020.

Availability:

This version is available at: 11583/2875029 since: 2021-03-18T12:14:37Z

Publisher:

I-RIM

Published

DOI:

Terms of use:

openAccess

This article is made available under terms and conditions as specified in the corresponding bibliographic description in the repository

Publisher copyright

(Article begins on next page)

Towards a PHM system for Electro-Mechanical Flight Control Actuators

Antonio Carlo Bertolino
Department of Mechanical and
Aerospace Engineering
Politecnico di Torino
Torino, Italy
antonio.bertolino@polito.it

Andrea De Martin
Department of Mechanical and
Aerospace Engineering
Politecnico di Torino
Torino, Italy
andrea.demartin@polito.it

Giovanni Jacazio
Department of Mechanical and
Aerospace Engineering
Politecnico di Torino
Torino, Italy
giovanni.jacazio@polito.it

Massimo Sorli
Department of Mechanical and
Aerospace Engineering
Politecnico di Torino
Torino, Italy
massimo.sorli@polito.it

Abstract—This paper describes the roadmap of an on-going research effort aimed at the design of a novel Prognostics and Health Management system for electro-mechanical actuators employed as secondary flight control systems.

Keywords—PHM, EMA, Flight controls, Ball screws

I. INTRODUCTION

Prognostics and Health Management is a relatively new, multidisciplinary research field aimed at the definition of routines capable of predicting the Time-of-Failure (ToF) of a defective system or component based upon a set number of signals (or “features”) extracted from the system itself. The capability to anticipate the failure occurrence and to estimate the Remaining Useful Life (RUL) of a system or a component would provide a set number of valuable advantages. In particular, if completely realized, it would provide important strategic information pertaining the opportunity to perform maintenance operations, the available time-window to successfully replace the faulty component, and eventually advice or provide an automatic reconfiguration of the defective system to compensate the effects of the degradation or to extend the RUL. Although application-agnostic in nature, PHM is of particular interest for aerospace applications, where the occurrence of unanticipated failures causes the disruption of the aircraft availability, which is a costly and potentially dangerous situation in both commercial and military aviation. As such, the benefits of PHM are not limited to the optimization of the maintenance policy and a reduction of its costs, but have significant ramification over the maintenance logistics (spare parts, personnel, dedicated facilities...), business choices (spare aircrafts number) and eventually strategic decisions (finish mission/return to base). Within this frame, on-board actuation systems are one of the most critical aircraft systems, and one of the major causes of disruption of aircraft availability. The vast majority of currently in-service flight control actuators belongs to the Electro-Hydraulic or Electro-Hydrostatic category. However, the growing push towards the design of “more-electric” aircraft encouraged several research activities aimed at the design and certification of Electro-Mechanical solutions. Compared with the hydraulic technology, Electro-Mechanical Actuators (EMAs) completely avoid the environmental and cost issues associated with the use of aggressive hydraulic fluid, provide significant advantages in terms of reliability and system layout design, and offer a combination of weights competitive with the hydraulic counterpart, especially for low power requirements. Despite these advantages, EMAs are seldomly used in flight-control systems, and mostly limited to UAVs or non-safety critical controls, due to their susceptibility to single-points of failure which can cause potentially catastrophic events like the jamming of the aerodynamic surface. Although these issues must be solved by design or through changes in the flight control architecture,

the definition of a reliable PHM system would potentially help to mitigate the probability of jamming, thus pushing the adoption of EMA technology. This manuscript focuses on the description of an on-going research effort aimed at the study of a PHM framework for EMAs of secondary flight control surface. At first, the proposed PHM system is described, hence a brief summary of the on-going activity is presented. Finally, future developments and expected results are proposed.

II. THE PHM FRAMEWORK

The proposed PHM framework for Electro-Mechanical flight control actuators is derived from previous experience on Electro-Hydraulic systems and reported in Figure 1 [1,2]. A major aim of the on-going study is to limit at a minimum, or completely avoid, the use of additional sensors, hence relying mostly on device already present on the actuator for control purposes. Signals from these sensors are hence acquired, post-processed and used to build the features used to perform diagnostics and prognostics operations. C-BITs and P-BITs are run in parallel to the acquisition and processing of the EHSA signals that generates the health indexes. The PHM functions can be conceptually grouped in a few modules. The Feature extraction / condition assessment module processes all available signals to generate the most significant features. The same module applies also de-noising techniques to raw signals accepted from the sensors. In addition, the module receives the indication of the operational condition (in-flight, on-ground, EMA active or in standby), that concur to the definition of the features. The Reasoner module receives the stream of features and performs the function of determining whether the EMA is healthy or faulty through the fault detection algorithm, and eventually, disambiguates among the possible different faults causes and location through the fault classification routine. Finally, the prognostics algorithm, based upon a particle-filter routine, provide an estimate of the Remaining Useful Life of the faulty component, along with information on its probability distribution and the estimated risk associated with each value of the RUL distribution.

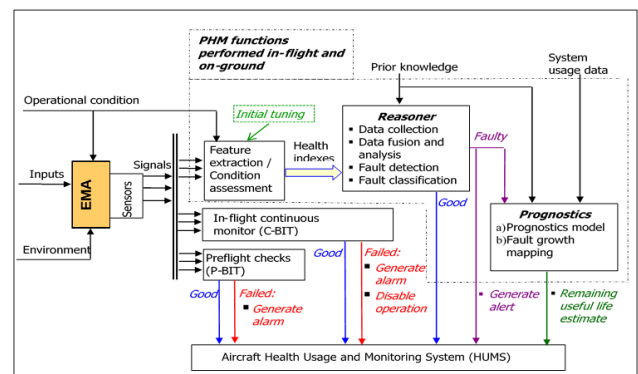

Fig. 1. The PHM framework [1]

III. ON-GOING ACTIVITIES

To pursue the design of the PHM system, we employ a hybrid approach based upon high-fidelity modeling of the system supported by seeded-fault laboratory tests following previous experiences on Electro-Hydraulic Servoactuators, shown in Figure 2 [2]. Starting from the definition of the use case, a secondary flight control actuator, a high-fidelity model of the system is prepared. A complete FMECA analysis is performed for the system under analysis, and the most significant failure modes selected according to frequency of occurrence, severity, observability and replaceability of the degraded component. The fault-to-failure process of these selected degradations is hence modelled according to the available literature and added to the high-fidelity model. The resulting simulation environment is hence used to perform a statistically representative number of simulated flights, which operating conditions, loads, and imposed commands are derived from operational data. Laboratory tests are meanwhile performed to support the model validation in both healthy and degraded conditions, by physically injecting faults of known size on the tested actuator.

The simulated flight data base is hence used to design the PHM system in each of its function; at first, a set number of features are selected from a pool of candidates according to their correlation with the studied faults, signal-to-noise ratio, accuracy and so forth. The fault diagnosis is performed through a data-driven fault detection algorithm combined with a classification routine (usually a Support Vector Machine or Artificial Neural Network). Finally, the prognostic algorithm is defined and tested against a number of degradation patterns.

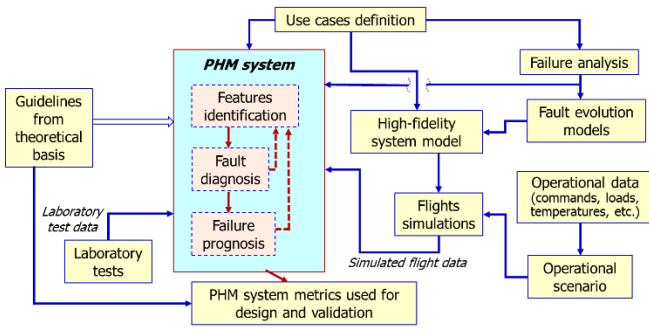

Fig. 2. Methodology [2]

A. Analytical activities

The analytical activities are focused on the definition of the high-fidelity model and the generation of the datasets used to train and test the PHM routines. The simulation environment must be able to represent the system behavior and its uncertainty and must accept the introduction of both known sized degradations and naturally evolving ones. This means that the actuators physical characteristics will be drawn from a pool of normally-distributed values centered around the nominal design one and that each variation of the physical characteristics of the device or of its performances in function of temperature, humidity, and applied load is derived from a probabilistic approach. Inputs to the model representing the operational conditions and the commands received by the system under analysis must be as realistic as possible, time dependent and randomized according to reasonable expectations of the application object of the study. From here, the proposed approach follows two consequential steps, needed to provide the data-base to design and test the PHM algorithms. At first, simulations are performed considering several levels of increasing and known fault severity for each considered failure mode, including healthy conditions. This

stage is needed to provide an in-depth statistical characterization of the system behavior under healthy and progressively more and more faulty conditions, hence providing a statistically representative data-set on which extract a set of features. The second step is to pursue time-dependent simulations in which the fault is artificially initiated and hence let free to evolve according to their own physics of failure equations. This operation is required to obtain realistic degradation patterns for each considered failure mode, and hence to test the PHM routines under realistic conditions. With regard to the case study, these tasks have been translated into an in-depth model of the EMA under analysis, comprehensive of a functional model of the Electronic Power Unit, and a complete three-phase model for the electric motor [3]. Since the ball screw is the component mostly responsible for jamming issues, particular care was dedicated to the definition of its model. Starting from a simplified unidimensional lumped mass model with a total of five degrees of freedom [4,5], a fully comprehensive multibody model has been developed in the Simscape Multibody environment [6–8], shown in Figure 3. In its latest version it allows to describe the full dynamic of each subcomponents, simulating each sphere individually and describing in detail their mutual interactions and the frictional behavior with the screw shaft and nut grooves in presence of grease lubrication. Several mutually interactive and time dependent degradations could be inserted, such as grooves' wear, thermal effects on geometry, lubricant starvation and ageing.

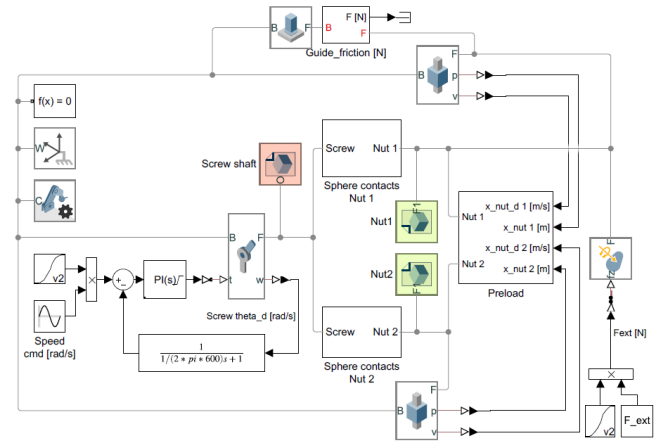

Fig. 3. Main screen of Simscape Multibody ball screw model [7]

Finally, an in-depth model of the rod-end has been pursued. The most interesting or critical degradation patterns have been modelled as well; issues in the DC-Link and in the MOSFET have been described, while issues in the electric motor and in the mechanical components have been modelled following the traditional literature available on the subject. A set of more than 100 simulations for each degradation level for each considered failure mode has been prepared, and the results used to select a number of features [9]. Features behavior are then studied in function of temperature variations, flight regime and actuator behavior. In example, some features might be more susceptible to fault presence and evolution during certain flight segments, or during certain operating conditions. In example, features connected with motor windings condition and bearings can be computed only when the actuator is moving [3]. The computed features are analyzed through a data-driven fault detection algorithm to observe the presence of one or more growing faults. The

choice of the algorithms is strictly related to the application and the overall strategy defined for the PHM activities on the platform or on the fleet. Parts or the entirety of the PHM process could be performed on-board, requiring algorithms and post-processing techniques designed to work over data streams. Having to deal with the implementation of these routines on iron-bird hardware, computational effort and RAM availability have been considered as an additional discriminant. For the case under analysis we elected to use a purely data-driven algorithm for fault detection; this methodology is straightforward in the implementation, requires limited computational and memory requirement and is suitable for on-line analysis. The fault detection algorithm provides two outputs; the first is the feature vector f , which elements are the values of each of the computed features. The second output is an alarm vector, which consists of Boolean variables associated to each failure mode, where the state is 1 when an anomaly is detected and 0 when conditions are deemed healthy. The fault classification is instead pursued via a Linear Support Vector Machine (LSVM); to favor the separation between data belonging to healthy and faulty conditions, the input to this routine is the element-by-element product of the feature vector and the alarm vector. Finally, a prognostic framework based on particle filtering is used to forecast the fault evolution in time and estimate the actuator's Remaining Useful Life. Particle Filters are Bayesian estimator for non-linear, processes affected by non-Gaussian noise; it combines a degradation model linking the features value with the expected fault size, and a tunable time-dependent model to forecast the fault progression in time up to failure occurrence. A storm of particles, resampled according to one of several schemes available in literature, is used to estimate the fault size and compare the resulting features with the ones computed through the EMAs' signals. Remaining Useful Life is estimated by comparing the algorithm projections with a threshold distribution representing the failure conditions, hence allowing to extract the probability distribution of the time-of-failure (or End-Of-Life) of the component.

B. Experimental activities

The model validation under healthy conditions follows a simple methodology, but requires a higher degree of care with respect to a traditional model identification problem, since the final aim is to validate the dynamic model and the baseline distribution for the selected features, which are usually computed as combination of different signals. This translates into the need of pre-allocating resources to insert additional sensors to the test bench. Validation of the model for degraded conditions is instead more complicated. Theoretically, this step of the development process should see the injection of known, controllable and progressively increasing degradation levels within the real device. The introduction of real, physical degradations on the system under analysis is not always feasible, both from an economical and practical standpoint. For EMAs employed in flight-control systems, the cost of physically injecting degradations can quickly ramp up, and alternatives, such as physically simulating the fault presence, need to be explored. The second major issue to the validation of the degraded condition model is the requirement to monitor the size or the severity of the tested degradation. PHM is of course aimed at this, but to evaluate how the algorithms and

the whole set up fares, we need a precise quantification of the injected fault extension. In some cases, this operation is quite simple (i.e., measure of a fixed size notch on bearings track, cracks), but more complex components present additional challenges. To pursue this step, two dedicated test benches are being used. The first is dedicated to the study of the overall behavior of the EMA under realistic load conditions and is depicted in Figure 5 [10]. The second test bench, shown in Figure 4 and currently under construction, is instead dedicated to the study of ball screw behavior in degraded and healthy conditions to support the theoretical findings obtained from the model regarding the mechanical efficiency [4], the no-load drag torque [11] and the degradations evolution [6]. Activities on these test benches are on-going and results will be shown as more tests are performed.

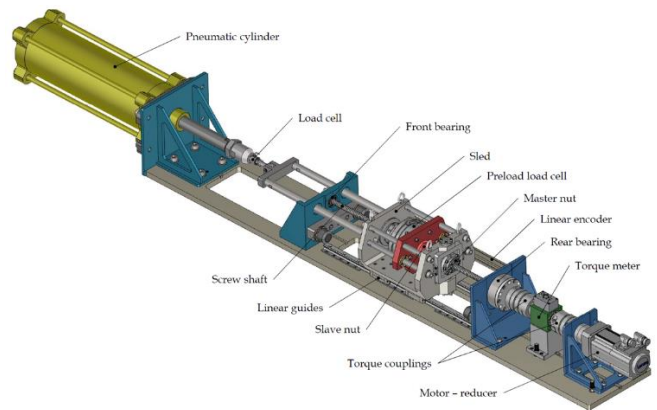

Fig. 4. Test bench for PHM on ball screws and model validation [12]



Fig. 5. Test bench for PHM on EMA flight controls [2]

C. Technology demonstrator

Laboratory tests are used to verify and eventually adjust the models of the EMAs and of the effects associated with the investigated degradations, but they have limited utility in validating a prognostic algorithm. They are in fact completely missing the time scale of the process and the interaction with the pilots and the other system can only seldomly be described. Moreover, laboratory tests are performed with dedicated commercial components, custom acquisition system and dedicated software for control, simulation, and data acquisition. To provide a more consistent technological

demonstrator factoring-in more effectively the time scale, and to verify the feasibility of PHM activities even from the computing hardware perspective, an iron-bird set-up is being prepared. The functional scheme of the portion of the system dedicated to Flight Control Systems (FCSs) is reported in Figure 6 [13]. The FCS of the set-up is partially based on real, newly designed actuators and partially by a real-time simulator (Actuator Simulation Module, ASM) which features simplified models derived from the high-fidelity environment. Since it is too expensive to introduce physical damages on the real system, degradations are introduced on the simulated EMAs according to the models validated through laboratory activities. Signals from all actuators, both real and simulated, are hence collected through a shared-memory architecture and sent to a dedicated unit (the Health Management System Module) which runs the PHM routines. The Health Management System Module has three main tasks: define and send to the ASSM which degradation type to inject and when, analyze the received data and provide results to the user. To limit the computational effort and to disengage the operation of the HMSM from those of the rest of the iron-bird, all the analyses are performed off-line, mimicking the expected implementation on real aircraft systems.

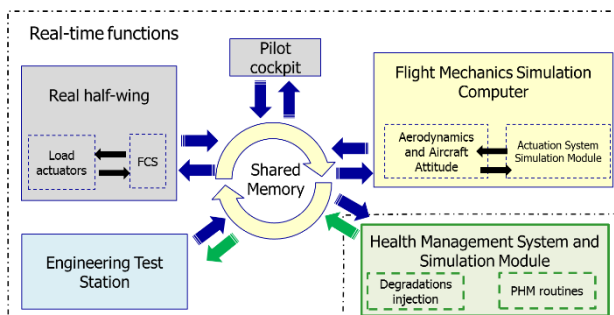

Fig. 6. Iron-bird functional architecture

IV. FUTURE DEVELOPMENTS

Both the experimental activities and the iron-bird integration are in progress and expected to provide results within the next year. Future development includes the validation of PHM algorithms and high-fidelity models on real data obtained from degraded EMA and, specifically, from ball screws. The models will be enhanced to describe more EMA's components and to deepen the understanding of the degradation physics.

- [1] Autin, S., Socheleau, J., Dellacasa, A., De Martin, A., Jacazio, G., and Vachtsevanos, G., 2018, "Feasibility Study of a PHM System for Electro-Hydraulic Servo- Actuators for Primary Flight Controls," *Annual Conference of the Prognostic and Health Management Society*, pp. 1–19.
- [2] Autin, S., De Martin, A., Jacazio, G., Socheleau, J., and Vachtsevanos, G., 2020, "Results of a Feasibility Study of a Prognostic System for Electro-Hydraulic Flight Control Actuators," *Int. J. Progn. Heal. Manag.* "in press"
- [3] De Martin, A., Jacazio, G., and Vachtsevanos, G., 2017, "Windings Fault Detection and Prognosis in Electro-Mechanical Flight Control Actuators Operating in Active-Active Configuration," *Int. J. Progn. Heal. Manag.*, **8**(2).
- [4] Bertolino, A. C., Sorli, M., Jacazio, G., and Mauro, S., 2019, "Lumped Parameters Modelling of the EMAs' Ball Screw Drive with Special Consideration to Ball/Grooves Interactions to Support Model-Based Health Monitoring," *Mech. Mach. Theory*, **137**, pp. 188–210.
- [5] Bertolino, A. C., Jacazio, G., Mauro, S., and Sorli, M., 2017, "High Fidelity Model of a Ball Screw Drive for a Flight Control Servoactuator," *IMECE*, ASME, ed., ASME, Tampa, Florida, USA, p. V001T03A024.
- [6] Bertolino, A. C., 2020, "High Fidelity Model of Ball Screws to Support Model-Based Health Monitoring, Ph.D. Thesis," Politecnico di Torino.
- [7] Bertolino, A. C., Mauro, S., Jacazio, G., and Sorli, M., 2020, "Multibody Dynamic Model of a Double Nut Preloaded Ball Screw Mechanism with Lubrication," *IMECE Volume 4: Dynamics, Vibration, and Control*, ASME, ed., ASME, Portland, OR, USA.
- [8] Bertolino, A. C., Jacazio, G., Mauro, S., and Sorli, M., 2019, "Developing of a Simscape Multibody Contact Library for Gothic Arc Ball Screws: A Three-Dimensional Model for Internal Sphere/Grooves Interactions," *IMECE Volume 4: Dynamics, Vibration, and Control*, ASME, ed., American Society of Mechanical Engineers, Salt Lake City, UT, USA.
- [9] De Martin, A., Jacazio, G., and Sorli, M., 2019, "Integrated Health Monitoring for Robust Actuation Systems of UAV Primary Flight Controls," *Int. J. Mech. Control*, **20**(02).
- [10] Chiavarelli, P., De Martin, A., Evangelista, G., Jacazio, G., and Sorli, M., 2019, "Real Time Loading Test Rig for Flight Control Actuators Under PHM Experimentation," *ASME International Mechanical Engineering Congress and Exposition, Proceedings (IMECE)*, p. V001T03A032.
- [11] Bertolino, A. C., Jacazio, G., Mauro, S., and Sorli, M., 2020, "Investigation on the Ball Screws No-Load Drag Torque in Presence of Lubrication through MBD Simulations," *Mech. Mach. Theory*, (under review).
- [12] Bertolino, A. C., De Martin, A., Jacazio, G., Mauro, S., and Sorli, M., 2019, "Robust Design of a Test Bench for PHM Study of Ball Screw Drives," *IMECE Volume 1: Advances in Aerospace Technology*, ASME, ed., American Society of Mechanical Engineers, Salt Lake City, UT, USA.
- [13] De Martin, A., Jacazio, G., and Sorli, M., 2019, "Design of a PHM System for Electro-Mechanical Flight Controls: A Roadmap from Preliminary Analyses to Iron-Bird Validation," *MATEC Web Conf.*, **304**, p. 04018.