

Multiple-Notch Frequency Selective Surface for Automotive Applications

Original

Multiple-Notch Frequency Selective Surface for Automotive Applications / Buta, A. -P.; Silaghi, A. -M.; De Sabata, A.; Matekovits, L.. - ELETTRONICO. - (2020), pp. 439-442. ((Intervento presentato al convegno 13th International Conference on Communications, COMM 2020 tenutosi a rou nel 18-20 June 2020 [10.1109/COMM48946.2020.9142001]).

Availability:

This version is available at: 11583/2862162 since: 2021-01-19T14:44:28Z

Publisher:

Institute of Electrical and Electronics Engineers Inc.

Published

DOI:10.1109/COMM48946.2020.9142001

Terms of use:

openAccess

This article is made available under terms and conditions as specified in the corresponding bibliographic description in the repository

Publisher copyright

IEEE postprint/Author's Accepted Manuscript

©2020 IEEE. Personal use of this material is permitted. Permission from IEEE must be obtained for all other uses, in any current or future media, including reprinting/republishing this material for advertising or promotional purposes, creating new collecting works, for resale or lists, or reuse of any copyrighted component of this work in other works.

(Article begins on next page)

MULTIPLE-NOTCH FREQUENCY SELECTIVE SURFACE FOR AUTOMOTIVE APPLICATIONS

Adrian-Petru Buta^{1,2}, Andrei-Marius Silaghi^{1,2}, Aldo De Sabata¹, Ladislau Matekovits³, Catalin Balan^{1,2}

¹ Dept. of Measurements and Optical Electronics, University Politehnica Timisoara, Timisoara, Romania

² Dept. of Electromagnetic Compatibility, Continental Automotive Romania, Timisoara, Romania

³ Dept. of Electronics and Telecommunications, Politecnico di Torino, Torino, Italy

Contact author e-mail: andrei.silaghi@upt.ro

Abstract—A one-layer frequency selective surface (FSS) is proposed for wide-band and multiple-notch filtering applications. The structure consists of one or two pairs of modified square rings on one side of the supporting dielectric layer. Two, three and four notches are obtained by modifying the parameters involved. A parametric analysis concerning the frequency response in function of the substrate thickness is reported, demonstrating the possibility of changing the stop bands. By duplicating the structure on both sides of the FR4 substrate, a wide-band is obtained, for both TE and TM polarizations. The devised FSS can be used for filtering in the Wi-Fi, Bluetooth and X bands for Automotive applications.

Keywords—FSS; square ring; wide-band; X band

I. INTRODUCTION

Frequency selective surfaces (FSS's) have gained much attention in the engineering community, initially due to applications such as spatial filters, selective absorbers and reflectors [1,2]. The simplest practical implementation of FSS's consists of a periodic metal pattern imprinted on a dielectric substrate, which can be sometimes a cost-effective one, like FR4 [3]. However, more involved solutions have been proposed in the last years, such as switched [4], flexible [5] and even wearable FSS's [6]. The concept of FSS's evolved in the last years to metasurfaces, which are surfaces engineered to modify at will various parameters of wavefronts of electromagnetic waves, such as amplitude, phase, polarization, direction of propagation and focusing [7].

FSS's have found various applications in function of the frequency range, from GHz [3-6] going through THz [8] to Optics [7]. One of the applications in the 1-10 GHz range in which some of the authors of the present paper have been interested in in the past consists of selective shielding in view of filtering out signals of certain frequencies and letting pass unmodified signals at other frequencies in automotive EMC testing environment [9]. An example of this is keeping in an enclosure Wi-Fi signals still allowing for GSM communications with the exterior [2].

The present work proposes a simple structure to answer such a practical issue with final design goal on the Wi-Fi, Bluetooth and X bands, commonly used in the automotive industry.

A double sided FSS conceived for multi wide-band filtering applications is reported. The structure is built on a FR4 substrate, with a set of one and or two square rings on both sides. The filtering properties are assessed with a commercial solver [10]. A step-by-step presentation of the evolution of the metal pattern of the unit cell for obtaining the desired transmission properties is provided. Parametric studies are undergone for the substrate thickness to demonstrate the possibility of shifting the stop bands.

The paper is organized as follows. In the next section, the design of the FSS is presented and its filtering properties are assessed. In Section III, it is shown how the resonances of the surface can be combined by modifying the geometrical parameters to obtain a large stop-band. The last section is dedicated to conclusions.

II. PROPOSED STRUCTURE

A. Initial structure with one notch

The starting point for the design of the unit cell of the FSS is presented in Fig.1 (a) - side view and (b) - front view). It consists of one square ring made from copper on one side of an FR4 substrate ($\epsilon_r=4.3$, $\tan \delta=0.025$). The dimensions are as follows: substrate thickness - 3.2 mm, dimensions of the unit cell: $d_x=d_y=15$ mm (with respect to the reference frame in Fig. 1), trace width - 0.5 mm, square edge - 14.8 mm. The FSS results by 2D repetition of the unit cell in the d_x and d_y directions.

The transmission coefficient of the structure with one simple square ring on only one side of the substrate has been assessed first by using [10]. Such a design resonates at a single notch frequency determined by the perimeter of the square ring [1].

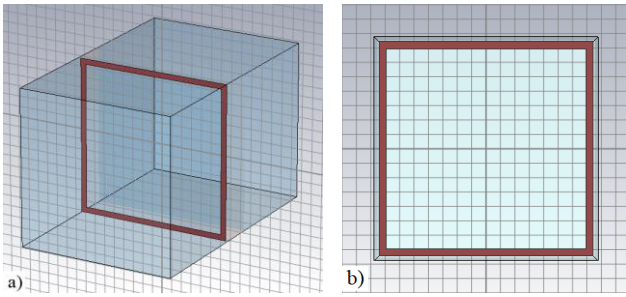

Fig. 1 Initial square ring structure: a) side view; b) front view

In Fig. 2 the magnitude of the transmission coefficient S_{21} of a linearly polarized plane wave in normal incidence is reported. The square ring, with different geometric dimensions, entered as a part of the structure introduced by the authors in [9], [11]. In this particular case, one notch frequency (2.1 GHz) has been obtained (Fig. 2), for a 10 dB stop-band in the range (1.43 – 2.89 GHz), i.e. a bandwidth of 1.46 GHz (69.52%), which covers the Wi-Fi and Bluetooth bands.

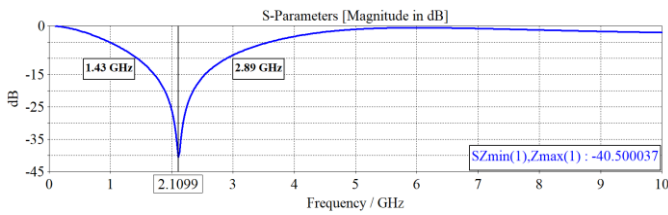

Fig. 2 Result for Fig. 1 (1 notch)

B. Modified structure with multiple notches

A modification allowing to obtain two notch frequencies is reported in Fig. 3 (a) - side view, (b) - front view): increasing the number of resonant elements by placing one extra square ring. The new parameter is: second square edge length = 7.55 mm with the same trace width as the initial square. In Fig. 4 the transmissions properties of this new structure are reported. The first 10 dB notch band extends from 1.54 GHz to 2.82 GHz (a band of 1.28 GHz with a notch centered on 2.18 GHz, i.e. 58.72% relative bandwidth) and the second one from 7.36 GHz to 8.32 GHz (a band of 0.96 GHz with the second notch being centered on 7.88GHz, i.e. 12.18%). The first notch is inherited from the outer square ring and the other ring determines the second notch. However, notch frequencies and bandwidths are also influenced by the interaction between the rings. [1].

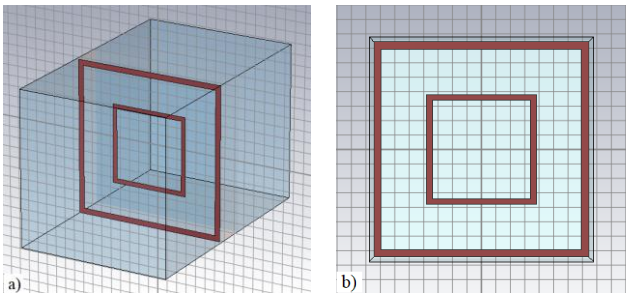

Fig. 3 Two square rings structure: a) side view; b) front side

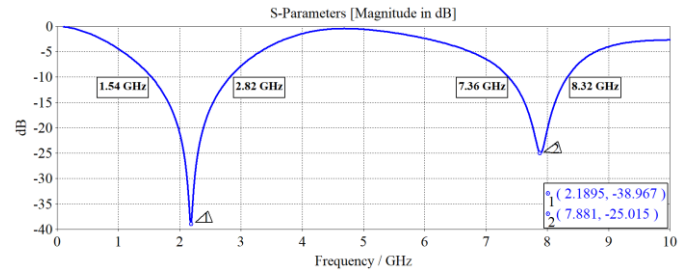

Fig. 4 Result for Fig. 2 (2 notches)

Next, in Fig. 5, the unit cell with modified dimensions and shape, based on a square ring is reported. The trace width w has been increased from 0.5 mm to 2 mm, the square ring has been squeezed, and four metal patches have been added in order to increase the number of resonances and enrich the frequency response. The side of the patches is $p/5.5$ mm, leaving the total length of the structure, in the x and y directions unmodified. The metal from the intersection regions of the patches with the interior of the square ring have been trimmed.

In Fig. 6 the transmission coefficient in TE polarization, between 0 and 20 GHz of the structure from Fig. 5, obtained using [10] is reported. A wide stop-band and also the occurrence of the two extra notches are visible. The first band, determined mainly by the square ring is displaced towards higher frequencies in Fig. 6 with respect to its position in Fig. 2 mainly due to the increase of the trace width and the decrease of the edge of the square.

The first stop-band starts at 2.83 GHz and stops at 7.36 GHz, thus we obtained a 10 dB stop-band of 4.53 GHz for (centered on 5.47 GHz, i.e. 82.81%). Although the absolute bandwidth of the stop-band is larger for the modified structure (Fig. 5) than for the initial one (Fig. 1), the relative bandwidth is similar in this case, indicating similar properties as filters. The next notch is obtained at 13.19 GHz, but with a small attenuation at the center frequency and a small 10 dB bandwidth; the third notch is centered at 16.49 GHz and it presents a 10 dB stop-band between 15.6 GHz and 17.8 GHz, i.e. 2.2 GHz bandwidth (13.34%).

The stop-band structure of the transmission coefficient is determined by the dimensions of the resonators and by their mutual coupling. The proposed metal pattern of the unit cell has a number of geometrical degrees of liberty that can be modified to obtain special cases with convenient filtering properties, fit for various applications. Various parametric studies have been performed in order to assess the flexibility of the proposed FSS. Some examples are presented next.

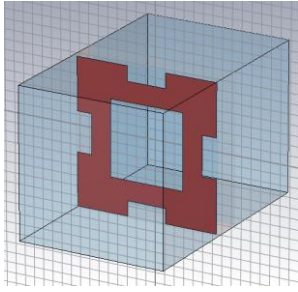

Fig. 5 Modified square ring structure

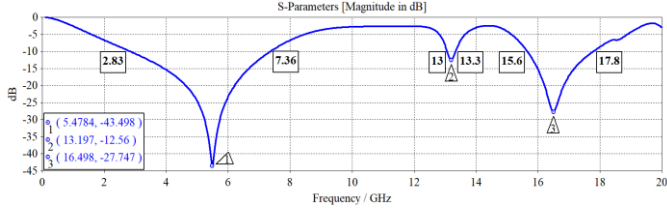

Fig. 6 Results for Fig. 3 (3 notches)

In Fig. 7, the shape of the unit cell obtained by performing modifications to the structure in Fig. 5, is presented. The modifications are as follows: the side of the patches have been reduced $pl=4.75$ mm, and the interior square ring has been brought closer to the center. (NU SE INTELEGE! CU CAT?)

In Fig. 8, the magnitude of the transmissions coefficient of this new structure is reported. When compared to Fig. 6, an extra notch appears, giving a total of 4 notches. The first wide stop-band extends from 3.4 GHz to 7.7 GHz (band of 4.3 GHz, centered with a notch on 6 GHz, 71.66%). The second notch is obtained at 12.79 GHz with a small stop-band around, however the attenuation at the central frequency is better than in the previous case for the second notch. The third notch occurs at 16.35 GHz, with a small stop-band between 15.8 GHz and 17.1 GHz (1.3 GHz bandwidth i.e. 7.95%), and the last one is centered at 20.17 GHz with a 10 dB band between 19.7 GHz and 20.5 GHz (0.8 GHz – 3.96%). Like in the preceding case, the first stop-band is inherited from the outer square ring (reported in Fig. 2 for different dimensions), while the metal patches and the interaction in between the elements determine the other notches.

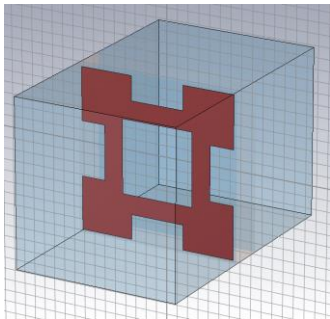

Fig. 7 Unit cell from Fig. 5 with modified parameters

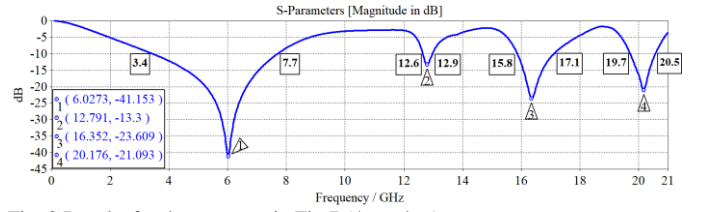

Fig. 8 Results for the structure in Fig.7 (4 notches)

C. Parametric study

A parametric study was done first for the structure from Fig. 5: variation of the FR4 substrate thickness. The modification of the substrate thickness changes the length of the wave path within the structure and impacts the frequency response [9].

As reported in Fig. 9, by changing this parameter from 3.2 to 1.6 mm (in steps of 0.4 mm) for the FSS with the unit cell represented in Fig. 5, the wide-band and the notches can be shifted in frequency.

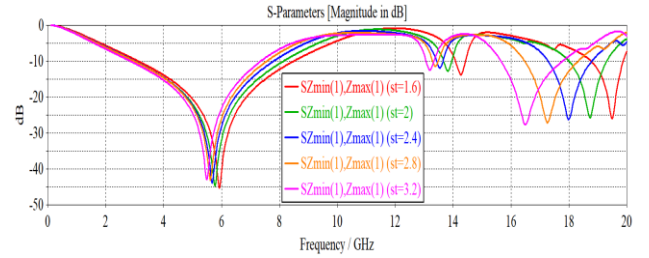

Fig. 9 Parametric study st for Fig. 5

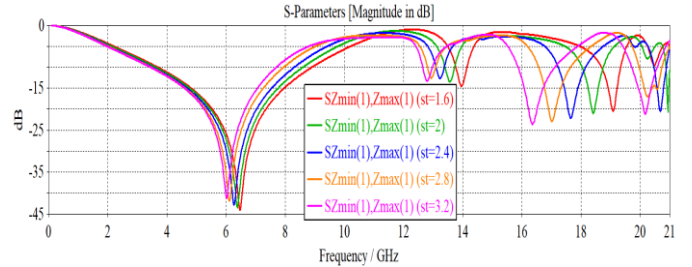

Fig. 10 Parametric study st for Fig. 7

By decreasing the substrate thickness the notches are shifted towards higher frequencies. The modification for the wide-band is not so visible, the central frequency covering a range of about 0.5 GHz. However, the second notch covers a range of about 1.5 GHz, while the third notch covers a range of about 3 GHz.

The same parametric study was repeated for the structure with the unit cell represented in Fig. 7: variation of the substrate thickness of the FR4 substrate by changing again this parameter from 3.2 to 1.6 mm (in steps of 0.4 mm). By decreasing substrate thickness we obtain in Fig. 10 a behavior similar to the one in Fig. 9. However, the third notch covers a range of about 5 GHz in this case.

III. PROPOSED STRUCTURE WITH WIDE-BAND PROPERTIES

It is well known that duplicating a pattern on the other side of the substrate has a great impact on the transmission coefficient due to coupling [1]. Although the patterns are

similar, the interaction of the incoming electromagnetic wave with the two sides of the board is not identical due to the different paths it takes to reach the two metal patterns.

In Fig. 11, the unit cell with two patterns (one on each side of the FR4 substrate) is represented. The structure is symmetrical; it consists of exact repetition of the structure from Fig. 7. In Fig. 12, the band-stop properties between 0 and 12 GHz of the structure from Fig. 11, obtained using [10] are reported for TE polarization.

A much wider stop-band than the one obtained by using a square ring on only one side is visible. It starts at 3.49 GHz and stops at 10.44 GHz, thus we obtained a stop-band of 6.95 GHz (99.78% with respect to the center of the interval). For TM case (Fig. 13) a remarkably similar behavior has been demonstrated.

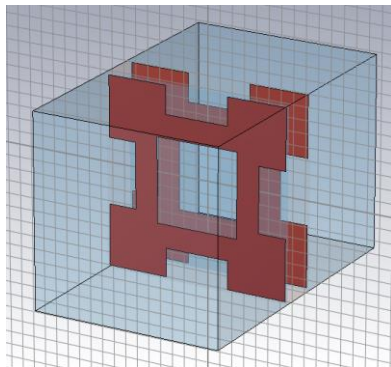

Fig. 11 Structure on both sides

The stop-band enlargement is motivated by the coupling between the square resonant structures on the two sides of the PCB. This case intersects the X band (frequency range 8-12 GHz), so this structure can be used for filtering in this area. By modifying geometrical parameters, the position of the stop-band can be shifted in frequency. In conclusion, by placing a square on both sides, a wide-band spatial filter is obtained.

To assess the sensitivity with respect to the angle of incidence of the electromagnetic plane wave, a parametric study on the structure in Fig. 11 has been performed. Due to symmetry of the structure, only variation of transmission coefficient with the colatitude angle has been considered. In Fig. 14 results of parametric variation of the colatitude angle (theta) have been reported. This parameter has been varied between 0 and 45° in 4 steps. Consistency for the wide-band can be seen in TE mode up to 45°.

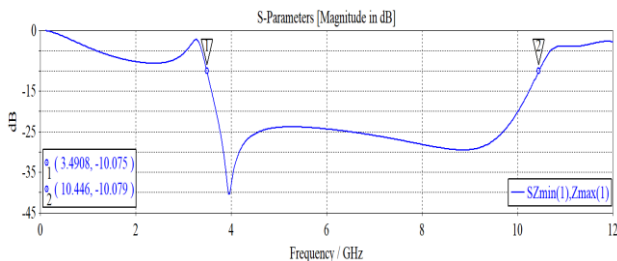

Fig. 12 Result for fig. 11 (wide-band) for TE polarization

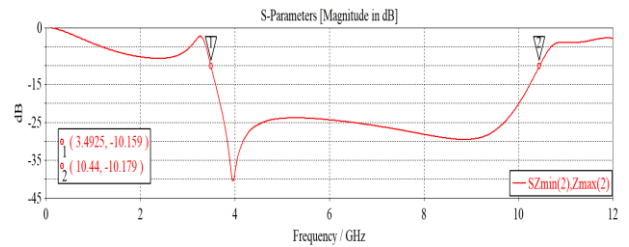

Fig. 13 Result for fig. 11 (wide-band) for TM polarization

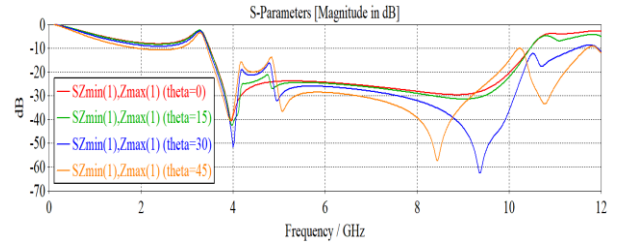

Fig. 14 Results of the parametric study for incidence angle (TE case)

IV. CONCLUSIONS

In this paper, FSS's built on an FR4 substrate, with unit cells consisting of metal patterns based on square rings and patches on one and both sides of the substrate have been proposed. The potential for applications of the proposed FSS's has been demonstrated by simulation with an electromagnetic CAD software package. It has been established that the proposed structure can work as Wi-Fi, Bluetooth and X band spatial filter for Automotive applications. The structures provide two or three stop-bands in the case of a single sided PCB, or it provides a large stop-band when the metal pattern is duplicated on the opposing side of the PCB.

ACKNOWLEDGMENT

This work was supported by a grant of the Romanian Ministry of Research and Innovation, CCDI-UEFISCDI, project number PN-III-P1-1.2-PCCDI-2017-0917/ contract number 21PCCDI.2018, within PNCDI III.

REFERENCES

- [1] B.A. Munk, Frequency Selective Surfaces - Theory and Design, New York: Wiley, 2000.
- [2] R.S. Anwar, L. Mao, H. Ning, "Frequency Selective Surfaces: A Review", Appl. Sci., vol. 8, pp. 1-47, 2018.
- [3] I.S. Syed, Y. Ranga, L. Matekovits, K.P. Esselle, S.G. Hay, "A single-layer frequency-selective surface for ultrawideband electromagnetic shielding", IEEE Trans. Electromag. Compat., vol. 56, no. 6, pp. 1404-1410, Dec. 2014.
- [4] R. Sivasamy, B. Moorthy, M. Kanagasabai, V.R. Samsingh, M.G.N. Alsath, "A wideband frequency tunable fss for electromagnetic shielding applications", IEEE Trans. Electromag. Compat., vol. 60, no. 1, pp. 280-283, Feb. 2018.
- [5] M Nauman, R. Saleem, A.K. Rashid, M.F. Shafique, "A miniaturized flexible frequency selective surface for X-band applications", IEEE Trans. Electromag. Compat., vol. 58, no. 2, pp. 419-428, Apr. 2016.
- [6] P. Gurrara, S. Oren, P. Liu, J. Song, L. Dong, "Fully conformal square-patch frequency-selective surface toward wearable electromagnetic shielding", IEEE Antennas Wireless Propag. Lett., vol. 16, pp. 2602-2605, 2017.

- [7] H.-T. Chen, N. Yu, "A review of metasurfaces: Physics and applications", *Rep. Prog.Phys.*, 79, 076401, 2016.
- [8] Z. Hamzavi-Zarghani, A. Yahaghi and L. Matekovits, "Dynamically tunable scattering manipulation of dielectric and conducting cylinders using nanostructured graphene metasurfaces, *IEEE Access*, vol. 7, pp. 15556-15562, 2019.
- [9] L. Matekovits, A. De Sabata, and A. Silaghi, "Frequency Selective Surfaces with Two Quasi-Independent Notch Frequencies," *IEEE Access*, Vol.7, Issue 1, pp. 77261-77267, June 2019.
- [10] CST, *Computer Simulation Technology* (v2019).
- [11] A. De Sabata, L. Matekovits and A. Silaghi, "Frequency Selective surface with two Notch frequencies and Good Incidence Angle Stability for Screening Applications ", 2018 International Conference on Electromagnetics in Advanced Applications (ICEEA 2018), 10-14 September 2018, Cartagena de Indias, Columbia, pp. 679-682, 2018.