

Monitoring of railway freight vehicles using onboard systems

Original

Monitoring of railway freight vehicles using onboard systems / Bosso, N.; Gugliotta, A.; Magelli, M.; Zampieri, N.. - In: *PROCEDIA STRUCTURAL INTEGRITY*. - ISSN 2452-3216. - ELETTRONICO. - 24:(2019), pp. 692-705. ((Intervento presentato al convegno 48th International Conference on Stress Analysis, AIAS 2019 tenutosi a Assisi nel 2019 [10.1016/j.prostr.2020.02.061]).

Availability:

This version is available at: 11583/2859060 since: 2020-12-27T15:49:35Z

Publisher:

Elsevier B.V.

Published

DOI:10.1016/j.prostr.2020.02.061

Terms of use:

openAccess

This article is made available under terms and conditions as specified in the corresponding bibliographic description in the repository

Publisher copyright

(Article begins on next page)



AIAS 2019 International Conference on Stress Analysis

Monitoring of railway freight vehicles using onboard systems

Nicola Bosso*, Antonio Gugliotta, Matteo Magelli, Nicolò Zampieri

Politecnico di Torino, Torino 10029, Italy

Abstract

Rail freight transport plays a key role in reducing polluting emissions, so major efforts are underway to strengthen the sector. However, this requires an improvement in the performance of the vehicles, and their more efficient use, with an increase of the axle-load and the speed. In relation to these aspects it is important to strengthen the safety of railway transport, by improving the maintenance system and at the same time reducing the vehicle's impact on the line, which can be achieved both by improving the technical characteristics of the vehicles and by reducing the geometric irregularities of the track. The possibility of extending circulation on High Speed lines also to freight vehicles is nowadays of great interest. The improvement of the maintenance level can be achieved by adopting procedures based on the actual condition of the vehicle ("on condition") instead of on the basis of cyclical programming (time or mileage). This requires knowledge of the actual condition of the vehicle and its components, which can be achieved by installing onboard monitoring devices capable of analyzing the behavior of the vehicle in real time. The work illustrates the experimental tests carried out using an innovative monitoring system, installed on board two different types of freight vehicles used for intermodal transport. The tests were performed on different lines: on the historic Gotthard line, and on the new Gotthard high-speed line, including the base tunnel. In this way, it was possible to demonstrate the application of the monitoring system to a rail freight vehicle. Furthermore, the results obtained in terms of accelerations measured on two different types of lines were compared, detecting the different impact of the vehicle on good quality lines compared to lines with significant defects.

© 2019 The Authors. Published by Elsevier B.V.

This is an open access article under the CC BY-NC-ND license (<http://creativecommons.org/licenses/by-nc-nd/4.0/>)

Peer-review under responsibility of the AIAS2019 organizers

Keywords: Monitoring, Railway Diagnostic, Onboard Monitoring

1. Introduction

The transfer of freight traffic from road to rail is one of the key elements to achieve a reduction in pollutions. For this reason, in recent times, the strengthening of rail freight transport is one of the most interesting aspects for the governments of industrialized countries.

The increase in rail traffic, however, must face the increased occupation of the lines and the greater incidence of the problems linked to this type of transport.

In countries such as the European Union, where the rail network is widely shared between freight and passenger traffic, this requires the need for more investment to improve the efficiency and safety of rail freight vehicles. The new development of the

* Corresponding author. Tel.: +39-0110906952; fax: +39-0110906999.

E-mail address: nicola.bosso@polito.it

railway networks, with the construction of new high-speed lines, does not necessarily lead to an improvement in the capacity of freight transport, especially if the freight vehicles are not allowed to transit on the new lines. For this reason, the promiscuous use of high-speed lines could represent a solution to the increase in traffic. However, this solution requires an assessment of the impact of the freight traffic on the line, as well as a significant improvement in the efficiency and safety of the freight vehicles used, in order to avoid accidents and unavailability of the line. In Europe, rail freight traffic mainly adopts vehicles based on the Y25 bogie, described by Bosso et al. (2002), or its variants.

It is a bogie with a single suspension stage, a reduced wheelbase (1.8 m) and a vertical friction damper. This vehicle, in the most advanced versions, can reach a maximum load of 25 t/axle or a maximum speed of 160 km/h by fitting disc brakes, however most vehicles are equipped with brake blocks with a speed limitation of 120 km/h.

The improvement of the efficiency and safety of these vehicles, if we exclude the possibility of designing a different type of bogie, can be achieved by improving the maintenance process, and in particular by moving from mileage or time maintenance to on-demand maintenance.

This type of solution must be assisted by different strategies to verify the vehicle, which must allow to detect promptly the conditions of the components to be replaced. This can be done using monitoring systems, which analyze the condition of the vehicle during normal operation. The monitoring systems can be installed on the track or mounted on the vehicle. The first type of sensors is normally managed by infrastructure managers and they mainly have a diagnostic purpose for operational safety. Vehicles in which non-conformities are detected are removed from the service pending maintenance work.

In the past, different types of fixed monitoring systems have been developed, the first of which have been those related to the thermal monitoring of bearing boxes, as shown by Tarawneh et al. (2018), which are currently widespread on European networks. Other types of fixed systems allow the detection of the axle load or wheel-load of the railway vehicle, allowing to detect a shift of the load on the vehicle.

More recently, fixed systems have been built which, by means of acoustic (Liu et al. 2017) or vibrational measurements, are able to detect defects in the rolling surfaces of the wheels, defects in the bearings or in the vehicle's suspension, as shown by Montalvo et al. (2018), Tournay et al. (2007). Finally, using image analysis, systems are being developed that can detect anomalies in the suspension, the gauge or the position of the load on the vehicles, as shown by Zhong et al. (2017).

However, the fixed detection systems are of little use to assist the maintenance operations to be carried out on the vehicle, as they are normally calibrated to detect the exceeding of threshold levels, and because the data are not normally directly available to the keepers of the vehicles, except in the event that non-compliance is detected.

For this reason, the other type of monitoring systems: onboard systems, are of greater interest for maintenance purposes. These systems, in addition to being able to perform an effective action to verify the safety conditions, can also promptly detect the degradation or malfunction of the components, as shown by Sneed and Smith (1998), Kuře et al. (2010), Li et al. (2017), Alemi et al. (2017), Bosso et al. (2018). Their application in the field of freight vehicles is currently not widespread, despite the growing interest in this technology, mainly for two reasons: the cost of installing the system, which in the freight sector has a significant impact, and the lack of electrification of the freight vehicles.

To overcome the first obstacle, it is necessary to develop monitoring systems and sensors at reduced cost.

To overcome the second obstacle, different types of generators or energy harvester to be mounted on the vehicles are instead being studied by Pan et al. (2019), Kalaagi (2019) and Brignole (2016).

The authors developed different types of monitoring systems at the Politecnico di Torino, initially designed for passenger vehicles, Zampieri et al. (2016), and subsequently modified to allow their application in freight vehicles, Bosso et al. (2018). This work illustrates the application of a monitoring system on freight vehicles suitable for intermodal transport. The system was subsequently tested in Switzerland, both on the traditional Gotthard line and on the new high-speed Gotthard line, a line that allows mixed traffic. The tests were carried out with the collaboration of SBB and Hupac S.A. during the testing phases of the new Gotthard Base Tunnel, as shown by Bosso et al. (2018), before it was opened to traffic.

The tests carried out allowed not only to verify the efficiency of the system in analyzing the condition of the vehicle, but also to compare the different impact of the vehicle on the new line compared to the traditional line.

2. Monitoring system

The measurement system used in the tests was developed at the Politecnico di Torino and represents an evolution of a previous system describe by Bosso et al. (2018), which was based on commercial acquisition components and a dedicated monitoring card for addressing and conditioning the signals. This architecture guaranteed a high modularity and longevity of the system as it was possible to replace some of the components separately.

However, since components are available on the market which enable a different monolithic architecture (a single monitoring board) to be realized at low cost, with the advantage of reducing the components and therefore increasing the simplicity and reliability of the system, this solution has been developed. and used in the tests illustrated in this work.

The new type of architecture that is described here has allowed to obtain a more integrated and easily engineered system. The changes concern the monitoring unit, which has been incorporated into a single electronic board called SMF. This board includes a multichannel acquisition system with simultaneous sampling, with sampling and signal conditioning differentiated according to the signal to be acquired (RTD, Accelerometer, Encoder, Thermocouple). It is controlled by a 32-bit ARM7 processor. This

processor contains a modifiable resident code, which supervises data acquisition and transfer, which can take place via Modbus / IP protocol or CAN network. An SD storage medium contains the resident code and can be used to save vehicle parameters or particular anomalous situations detected. The processing of the acquired data is carried out by a processing unit (Embedded PC) which must be placed on the data transmission line, but in this case, it is not necessary to have a processing system for each monitoring unit.

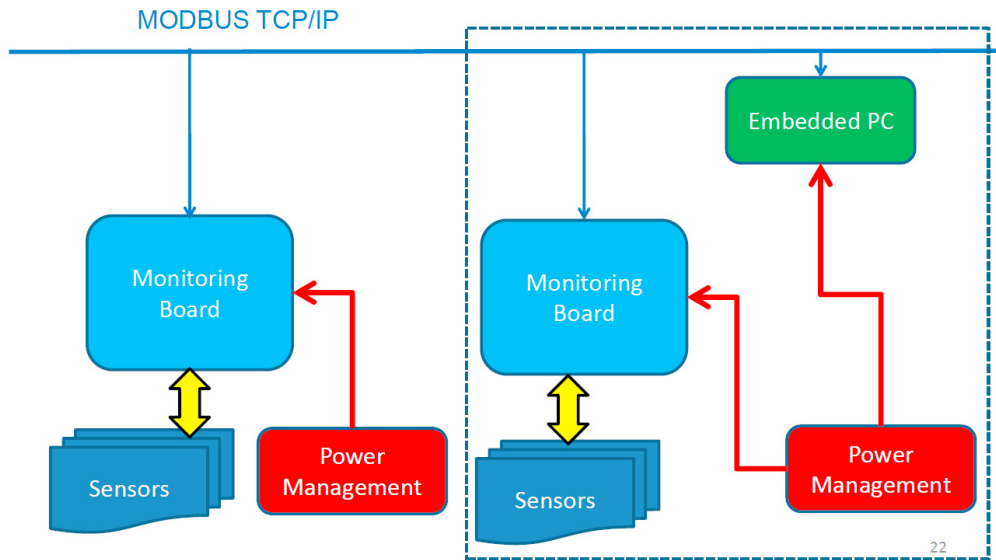

Fig. 1. Architecture of the monitoring system for a wagon with two bogies.

Fig. 1 represents the configuration of the system, which is considerably simpler than the original one shown by Bosso et al. (2018), by comprising a monolithic control unit which communicates with the sensors and deliver the data into the network.

In this way it is possible to reduce the number of processing units of the measured data (Embedded PC), to the limit to a single unit for the entire train. In the case of vehicles whose composition can be varied arbitrarily, it is instead preferable to maintain a processing unit per vehicle.

The system is designed to have a monitoring board for each bogie, therefore each vehicle normally has 2 monitoring boards and an Embedded PC, as shown in Fig. 1, or in the case of coupled vehicles (6-8 axles freight Vehicles) 3 or 4 monitoring boards and a Embedded PC only.

The system must be equipped with a power control board that can be coupled with the energy available on the vehicle (passenger vehicles) or independently generated (freight vehicles). In the case in question, given that the tests had a reduced temporal extension, a battery pack with an autonomy of about 8 hours was used to supply the energy to the monitoring system.

In order to realize an independent monitoring board, it is necessary that the this one has on board a microcontroller capable of managing data acquisition and transmission.

For this architecture, after an analysis of the processors available on the market, it was assumed to use a microcontroller based on ARM7 technology. The basic scheme of the monitoring board is shown in Fig. 2, where the microcontroller indicated in yellow supervises the signal acquisition functions and transmits the acquired data via Ethernet (ETH0). Some of the data, as well as the resident analysis program are stored in an internal memory (SD). The card is equipped with an RTC to synchronize the acquired signals.

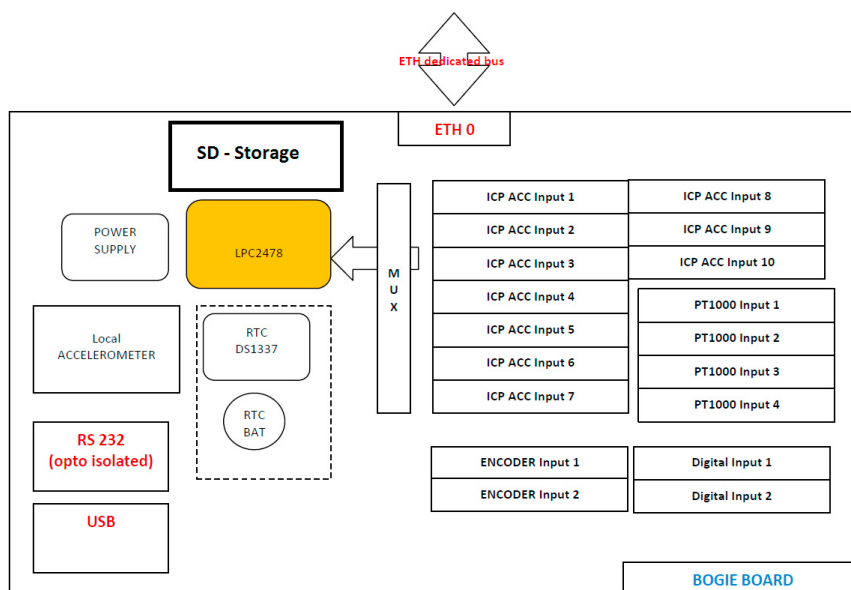

Fig. 2. Layout of the Monitoring Board

The monitoring board is designed to equip a vehicle bogie and, for each of the four axle-boxes of the bogie, includes a vertical accelerometer, a longitudinal accelerometer and a thermal probe. On one of the two axle-box of each axle, a lateral accelerometer is also installed, while on the opposite axle-box, an encoder is installed to detect the angular speed of the wheelset. The channels acquired are therefore the following:

- 10 channels for accelerometers (ICP or capacitive)
- 4 thermal probes (PT1000 or semiconductor sensors)
- 2 incremental 1024 pulse / rev encoders.
- 1 tri-axial capacitive accelerometer integrated in the board and mounted on the vehicle body

The Embedded PC, which completes the system, queries the monitoring boards present in the network, receives the signals acquired in the form of network packets according to a communication protocol (Modbus TCP / IP) and after processing them produces diagnostic indicators or alarm signals.

This processing unit is also able to store diagnostic data in order to maintain a record of the evolution of the vehicle conditions, or to carry out subsequent analyzes in the case of anomalous detections or damage / accidents. In the course of the tests illustrated in the present work, the measured signals were stored on a digital support (HD SSD) for the subsequent detailed analysis.

The capacitive accelerometers installed on the axle-box are tri-axial accelerometers with sensitivity 38 mV/g developed at Politecnico di Torino, the ICP accelerometers used during the tests have a sensitivity 100 mV/g, while the wheelset angular velocity is measured by means of a relative quadrature encoder with resolution of 1024 pulses for revolution. The tri-axial capacitive accelerometers installed on the coach is included in the acquisition board and has a typical sensitivity value of 174 mV/g. In the TASCA vehicle has been added an inclinometer ($\pm 5^\circ$ range) in order to measure the coach pitch and roll angles during the test, this sensor it is not usually installed in the measurement system when used for monitoring functions. The maximum sampling acquisition of the system is 20 kHz, but during the tests it has been set equal to 1 kHz, which is sufficient to evaluate the ride and track quality parameters.

2.1. Installation on the vehicles

The railway monitoring system (SMF) was installed on two wagons provided by the company Hupac S.A. These are two wagons used for intermodal transport of different types (CT-Light and Tasca 4.2).

The monitoring system consists of instrumented axle-box covers, replacing the existing covers, containing a thermal probe and accelerometers in the three directions. Some instrumented axle-boxes are fitted with an encoder capable of connecting, by means of a coupling system to the three bearing locking bolts mounted on the axle. The instrumented covers are made using two different technologies: equipped with ICP accelerometers and equipped with innovative capacitive sensors. Both solutions have been tested on the vehicle.

The instrumented covers are wired to the monitoring board which is mounted on the vehicle body and contains a temperature

sensor for the environment temperature, a tri-axial accelerometer for measuring accelerations in the vehicle frame and a biaxial inclinometer for measuring roll and pitch angles.

The wiring of the system is carried out according to the diagram in Fig. 3, using two intermediate junction boxes mounted on the side of the vehicle frame and connected to the two axle-box covers of the same side.

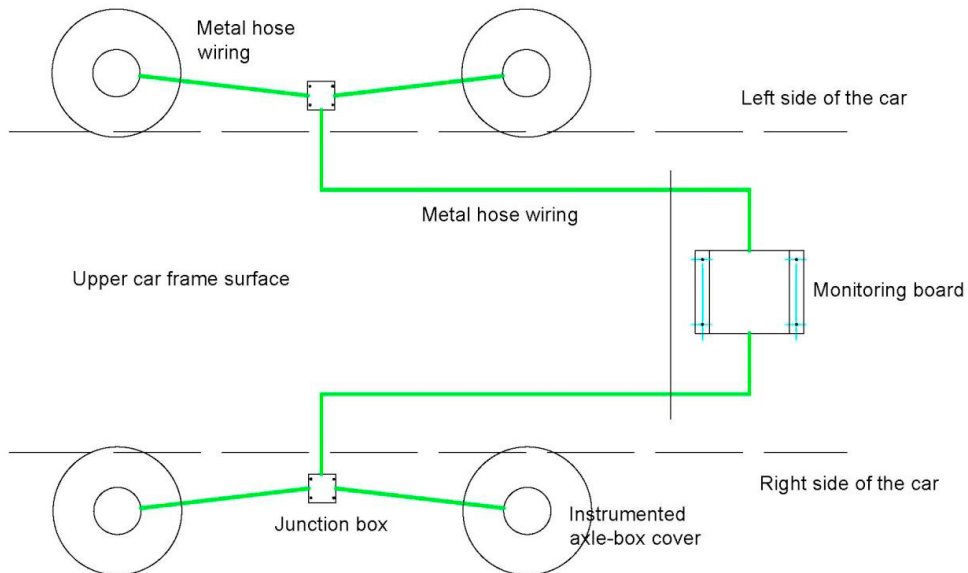

Fig. 3. Layout of system installation on the vehicle

The wiring is made using shielded multipolar cables, contained in a folded steel braided hose. The length of the wiring depends on the positioning of the control unit on the wagon. As regards the wiring made between the axle-boxes and the junction boxes located on the side of the wagon, a cable longer than necessary was created to take into account the relative rotation between the vehicle frame and the bogie.

In the case of curving, the angle that forms between the frame and the bogie depends on the curve radius R and on the bogie pivot length " i " according to the equation:

$$\sin(\psi) = \frac{i}{2 \cdot R} \quad (1)$$

Placing the junction box at a distance " b " from the middle of the bogie, during the rotation in curve, there is a relative longitudinal displacement between a point of the frame with respect to the same point of the bogie equal to Dx :

$$Dx = b \cdot \sin(\psi) = \frac{b \cdot i}{2 \cdot R} \quad (2)$$

Obviously, a wiring connected between the frame and bogie with a gauge " b " from the middle of the wagon can step away or approach by a length Dx depending on the direction of the curve and of the connection considered (front or rear axle).

Considering a minimum curve radius $R = 75$ m and an installation of the junction box at a distance $b = 1.2$ from the middle of the wagon, the movement Dx requested to the connection cable between the axle-box and junction box is equal to 116 mm for the wagon CT Light ($i = 14.46$) and 114 mm for the Tasca 4.2 wagon ($i = 14.20$). The wiring has been realized with an increase in length of 200 mm to avoid problems during curving.

The installation of the monitoring system on the two types of wagon was carried out differently due to the different arrangement of the load on the vehicle. On the CT Light chassis, the control unit was installed on the floor of the wagon in the front portion not occupied by the load as shown in Fig. 4. The axle-box covers fitted with ICP sensors were mounted on the right side, the ones fitted with capacitive sensors on the left side.

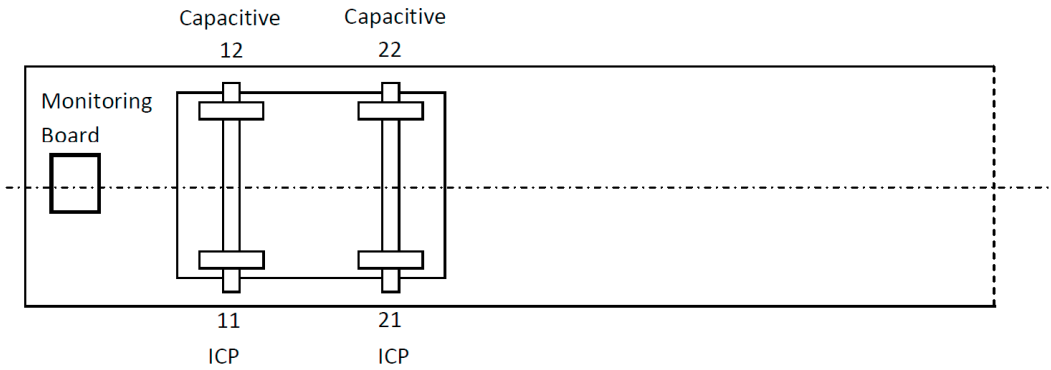

Fig. 4. Installation diagram on the CT-Light wagon.

On the Tasca type car, the control unit was installed under the vehicle frame on the right side, in the central portion. The axle-box covers fitted with ICP sensors were mounted on the first axle, the covers fitted with capacitive sensors on the second, as shown in Fig. 5.

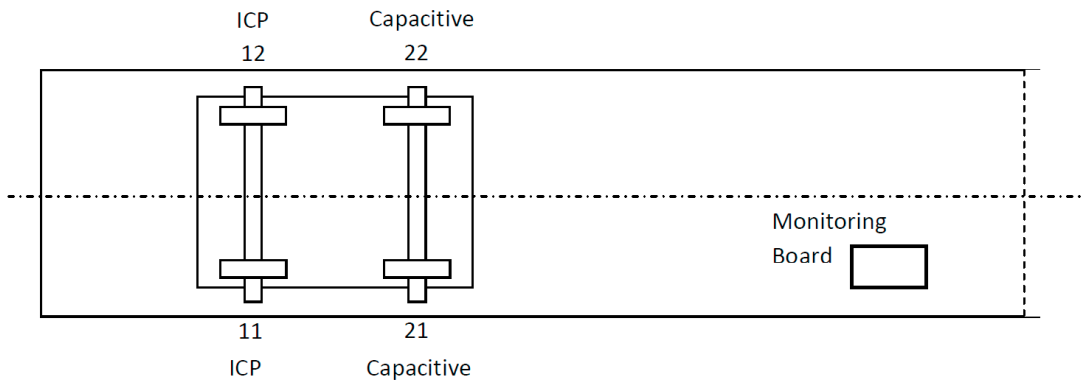

Fig. 5. Installation diagram on the Tasca wagon.

3. Track and test description

The tests shown in the paper have been performed in Switzerland, on the Gotthard Base tunnel between Biasca and Altdorf and on the old line, between Busto Arsizio and Aarau, in order to compare the performances of the two tracks in terms of vehicle accelerations. The tests on the Base tunnel have been performed considering different axle-load and different speed in order to test the new track under different conditions. Fig. 6 shows the equipped vehicles during the tests.



Fig. 6. Instrumented vehicles during the tests: a) Tasca 4.2 Wagon, b) CT-Light Wagon.

4. Experimental results

The data acquired during the tests on the Gotthard Base tunnel have been analyzed in order to evaluate the performances of the new track with respect to the “traditional” Gotthard tunnel. Considering the “new” tunnel the two vehicles (CTLIGHT and TASCA) have been tested with different speed. The data have been processed with statistical methods that consider 100 m long sections of track, as suggested by EN14363 standard. In this way it is possible to group the data and to immediately detect the track sections interested by evident irregularities or anomalies. The first analysis compares the behavior of the two vehicles running on a track section of 10 km during the test from Biasca to Altdorf (inside the Gotthard Base tunnel).

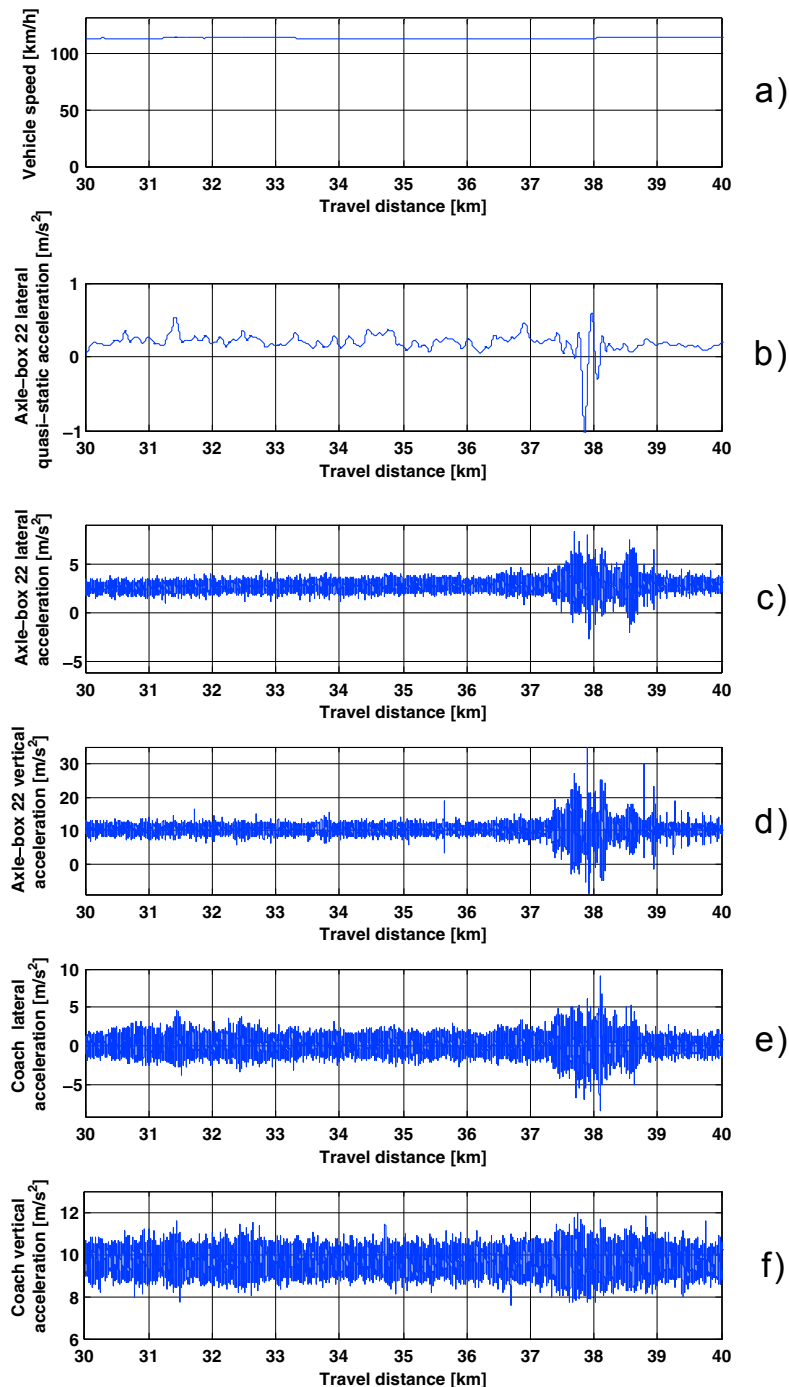

Fig. 7. Accelerations measured on the Gotthard base tunnel on the CTLIGHT vehicle.

Fig. 7 shows the results relative to the CTLIGHT vehicle where Fig. 7.a shows the vehicle speed during the test and Fig. 7.b shows the coach lateral acceleration filtered with a low-pass filter with cutoff frequency of 1 Hz. This acceleration is the non compensate lateral acceleration acting on the vehicle when running on curve or on switches. Fig. 7.c and 7.d show the axle-box 22 lateral and vertical acceleration, while in Fig. 7.e and 7.f are shown the lateral and vertical accelerations measured at the coach level. In this case, the acceleration has been filtered with a 4th order Chebyshev low-pass filter with 40 Hz cut-off frequency.

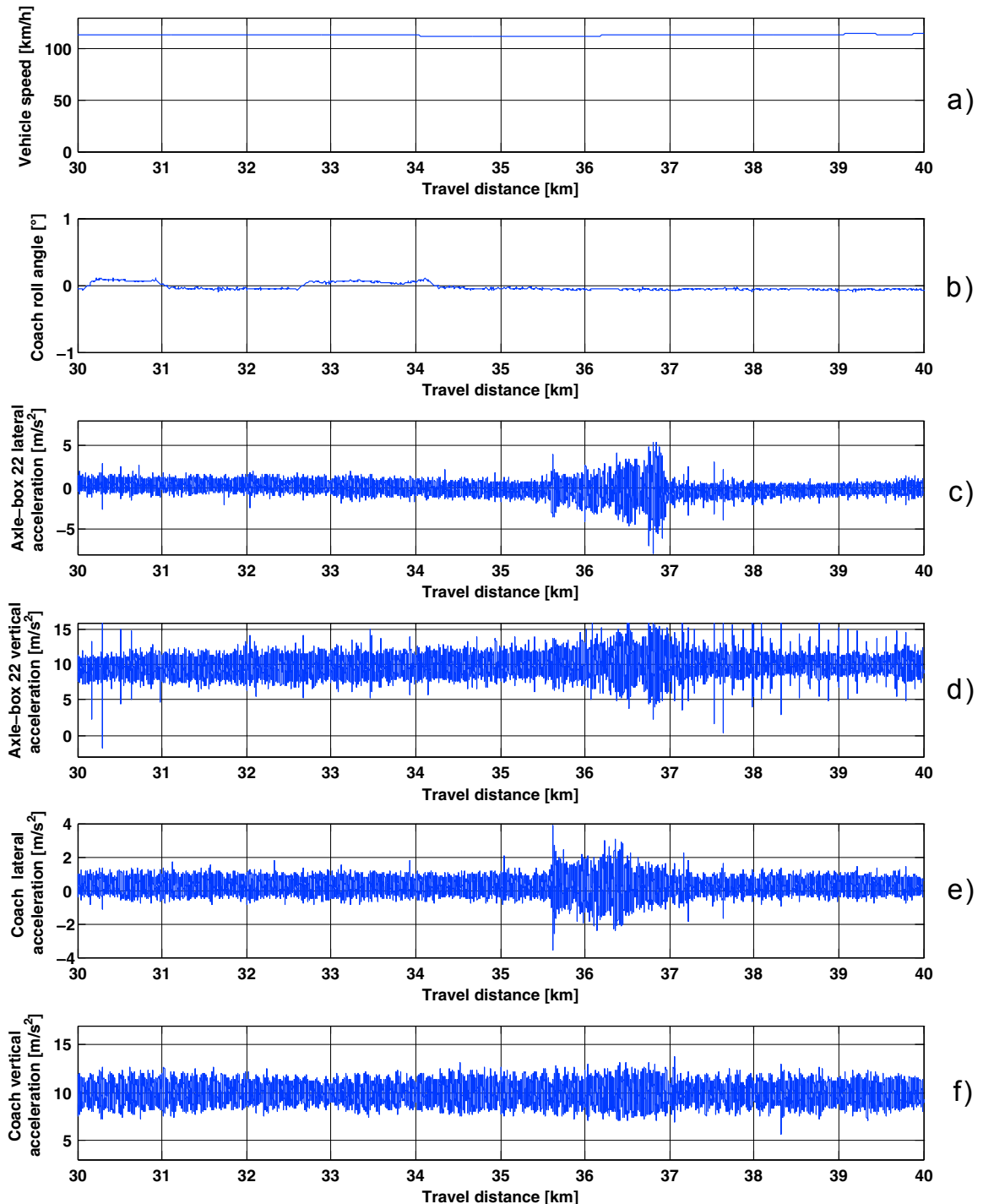

Fig. 8. Accelerations measured on the Gotthard base tunnel on the TASCA vehicle.

Fig. 8 shows the same quantities reported in Fig. 7, but relative to axle-box 31 of the TASCAs vehicle. Fig 8.b, instead of the quasi-static lateral acceleration, shows the coach roll angle measured with the inclinometer included in the measuring system of the TASCAs vehicle.

In Fig. 7 and Fig. 8 it is possible to observe at about km 36 an increment of the accelerations both in lateral and vertical direction corresponding to a coach quasi-static lateral acceleration equal to 1 m/s². In order to better analyze this part of the track a statistical analysis on the data was performed.

The track has been divided into sections of 100 m and on each section, the r.m.s. value and the 0.15% and 99.85% percentiles were calculated, as suggested by EN14363 standard. The acceleration signals are filtered with a 4th order band-pass Chebyshev filter in the range 4-10 Hz.

Fig. 9.a and 9.b respectively show the percentiles and the r.m.s values of the coach lateral acceleration for the CT-LIGHT and the TASCAs vehicles. The vertical accelerations for the same axle-box are instead shown in Fig. 10.a and 10.b. The r.m.s. and the percentile values allow to clearly identify the increment of acceleration starting from km 36. Furthermore, the lateral accelerations on the TASCAs vehicle are slightly higher than the accelerations on the CTLIGHT vehicle, while considering the vertical accelerations the situation is reversed and the accelerations measured on the CTLIGHT vehicle are about twice the ones measured on the TASCAs vehicle. This difference in the vertical direction is due to the different axle load and the different position of the freight cars with respect to the train composition. The TASCAs vehicle was tested in tare conditions, while the CTLIGHT vehicle was loaded with a 25 tons load placed on the side of the monitored bogie.

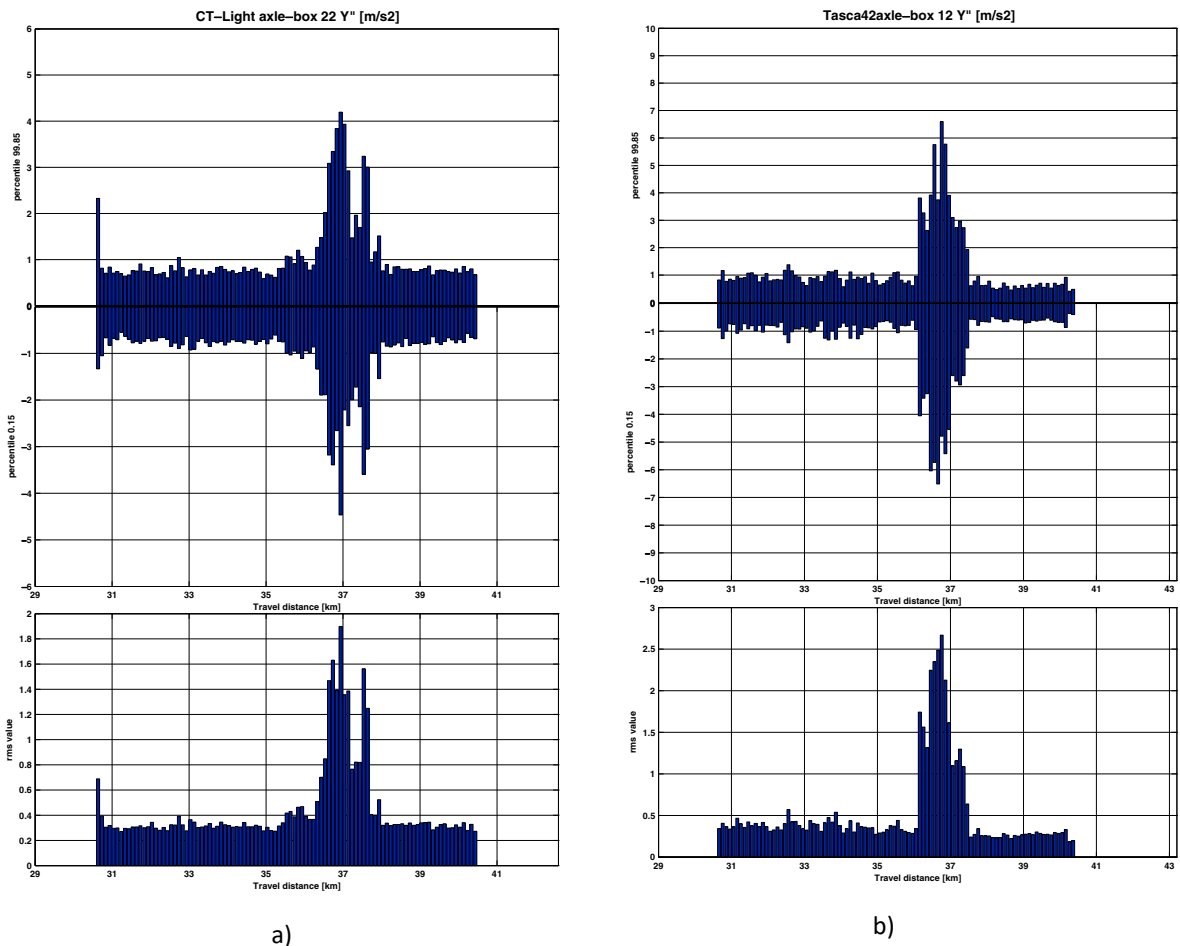

Fig. 9. Percentiles (0.15% and 99.85%) and r.m.s. values of the axle-box lateral accelerations measured on the Gotthard base tunnel on the CTLIGHT (axle-box 22) an TASCAs (axle-box 12) vehicles, passing on the switch section on the diverging route (km 37).

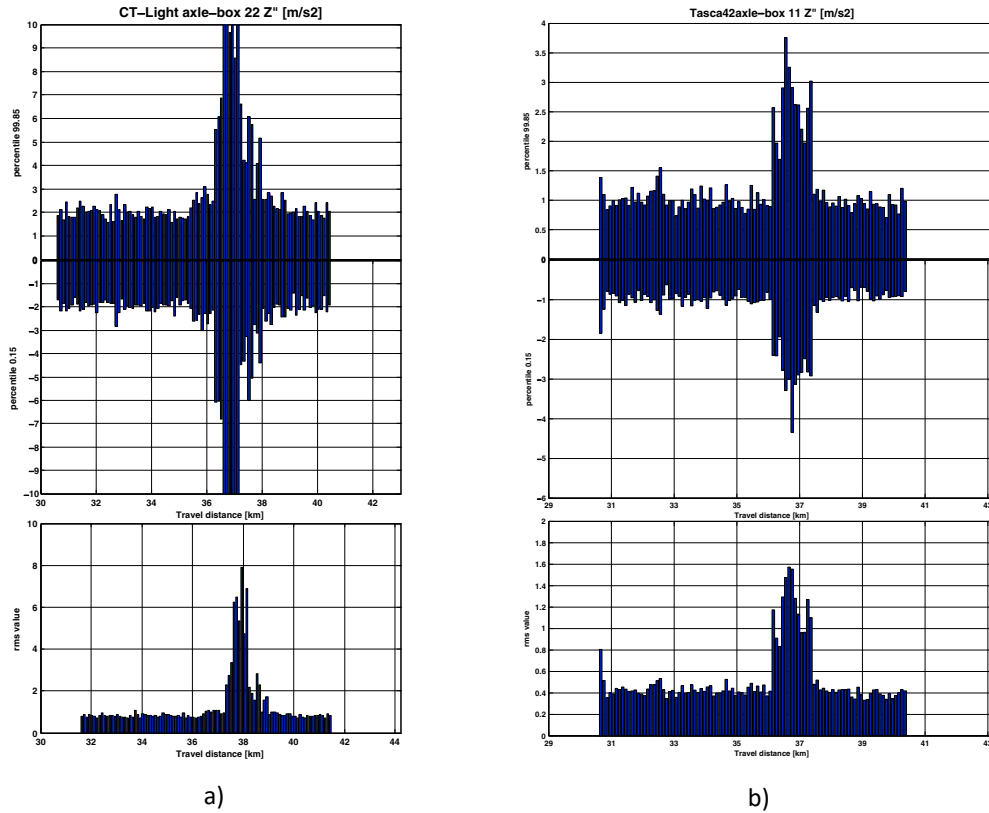

Fig. 10. Percentiles (0.15% and 99.85%) and r.m.s. values of the coach vertical accelerations measured on the Gotthard base tunnel on the CTLIGHT (axle-box 22) and TASC4 (axle-box 11) vehicles, passing on the switch section on the diverging route (km 37).

During the test, a camera was fixed on the coach and synchronized with the acquisition system, in order to relate the results with the track defects and singularities. The camera has been oriented to record the track and one wheel of the coach. From the analysis of the video at about the km 37, where the acceleration peak was detected, it is possible to notice the presence of a series of railway switches that is the cause of the acceleration increment. Fig. 11 shows the first railway switch located at the km 37.



Fig. 11. Detail of one vehicle wheel while running on the switch located at km 37 of the Gotthard Base tunnel.

A second analysis compares the effect of the vehicle speed with the accelerations measured on the vehicle axle-box in order to evaluate the impact of the vehicle on the track. The accelerations on the axle-box, in fact, are directly related with the forces acting between the wheel and the rail, which are responsible of the rail wear and deterioration. In order to analyze the effect of the vehicle speed the same vehicle, with the same axle-load and in the same track section, has been tested with speed of 115 km/h and 90 km/h.

Fig. 12.a and 12.b respectively show the axle-box 22 lateral accelerations measured during the test at about 90 km/h and 115 km/h on the CTLIGHT vehicle.

Comparing the two cases, it is possible to notice that the lateral accelerations on the axle-box are approximately the double when increasing the vehicle speed of the 30%. Also comparing the vertical accelerations, shown in Fig. 13.a and 13.b, it is possible to observe that accelerations are about the double when the vehicle is running at 115 km/h. In any case, the axle-box acceleration values are very low also when the vehicle is running at quite the maximum speed (120 km/h). The maximum percentile values of the lateral and vertical accelerations are respectively equal to 0.9 m/s² and 2.6 m/s², which are very low and ensure very low track stresses. Considering the acceleration peaks due to the switches inside the tunnel, shown in Fig. 9 and 10, the maximum value in lateral direction is 6.5 m/s² on the TASCAs vehicle, while in vertical direction is 18.2 m/s² on the CTLIGHT vehicle. These higher values of accelerations have been measured only where are located the switches and the vehicle is running at the maximum speed, and so are not related with the track quality. In general, on the basis of the accelerations measured on the two vehicles running on the Gotthard Base tunnel it is possible to conclude that the new track has a very high-quality level.

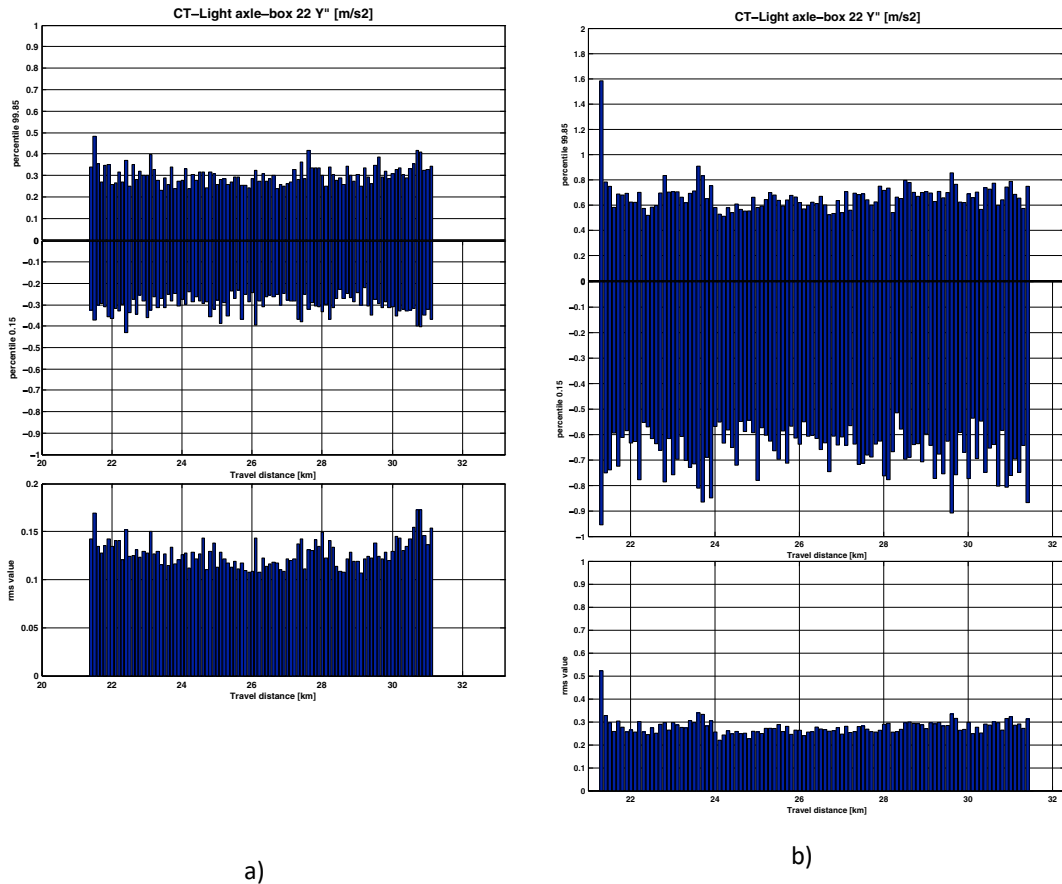

Fig. 12: Percentiles (0.15% and 99.85%) and r.m.s. values of the axle-box 22 lateral accelerations measured on the Gotthard base tunnel on the CTLIGHT vehicle running at about 90 km/h (a) and 115 km/h (b).

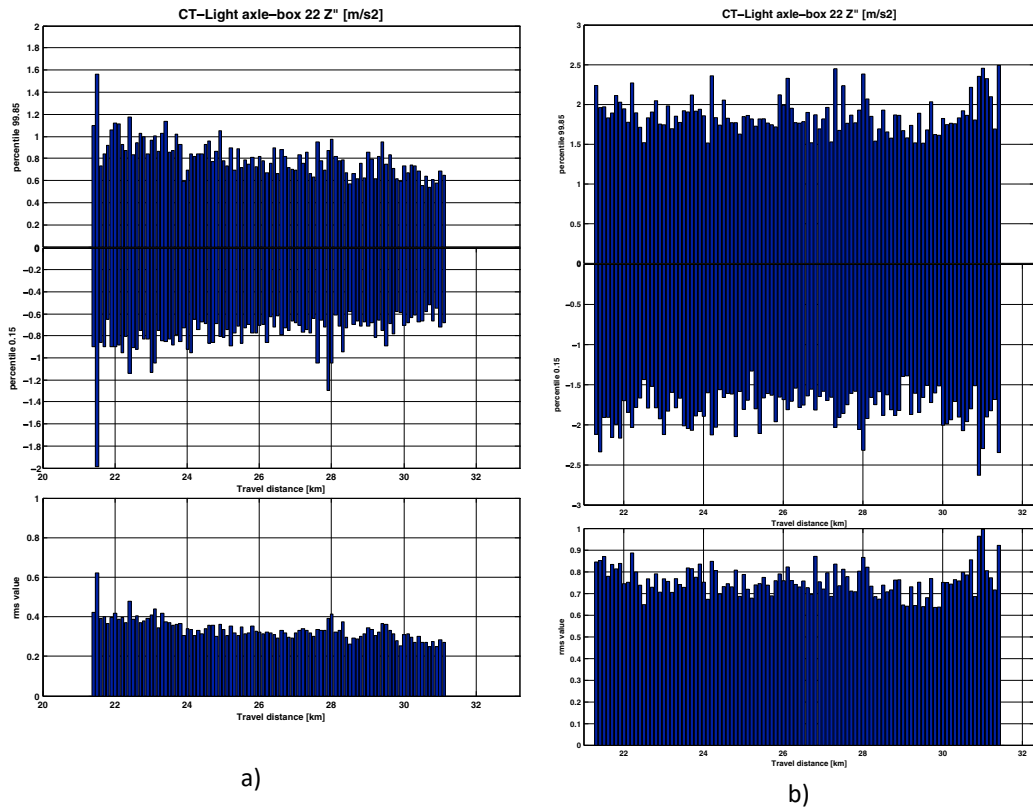

Fig. 13: Percentiles (0.15% and 99.85%) and r.m.s. values of the axle-box 22 vertical accelerations measured on the Gotthard Base tunnel on the CTLIGHT vehicle running at about 90 km/h (a) and 115 km/h (b).

In order to highlight the quality of the new track a further comparison is carried on, comparing the axle-box lateral and vertical accelerations measured on the new Gotthard Base tunnel with the ones measured on the “traditional” Gotthard tunnel. Also in this case, the comparison is performed on the same vehicle with the same axle-load and considering a track section where the vehicle is running at 90 km/h. In Fig. 8.a is shown the axle-box 22 lateral acceleration measured on the “traditional” tunnel which can be compared with the one, measured on the Base tunnel, in Fig. 12.a. Comparing the acceleration percentiles it is evident that the “old” tunnel has higher accelerations than the “new” one, in fact the maximum acceleration in the first case is 1.3 m/s², while in the second case is 0.42 m/s². Also considering the maximum value of the r.m.s. diagram the acceleration value on the “old” tunnel is much higher (0.48 m/s² vs. 0.17 m/s²). In general, the lateral acceleration on the “traditional” Gotthard tunnel are three times higher than the ones measured on the Gotthard Base tunnel under the same conditions. The axle-box vertical accelerations on the “old tunnel”, see Fig. 14.b, have a percentile and r.m.s. peak values equal to -3.6 m/s² and 1.2 m/s², while considering the acceleration measured on the Base tunnel, see Fig. 13.a, the percentile and r.m.s. peak value are equal to -1.3 m/s² and 0.48 m/s². Therefore, the same considerations for the lateral accelerations can be extended to the vertical ones and also in this case the ratio between the accelerations measured on the “traditional” and Base tunnels is about three.

The last analysis allows to conclude that the accelerations measured on the vehicle axle-boxes, when the vehicle is running on the Gotthard Base tunnel with a speed of 120 km/h (see Fig. 12.b and 13.b), are in general lower than the accelerations that occur on the same vehicle running on the traditional tunnel with a speed of 90 km/h.

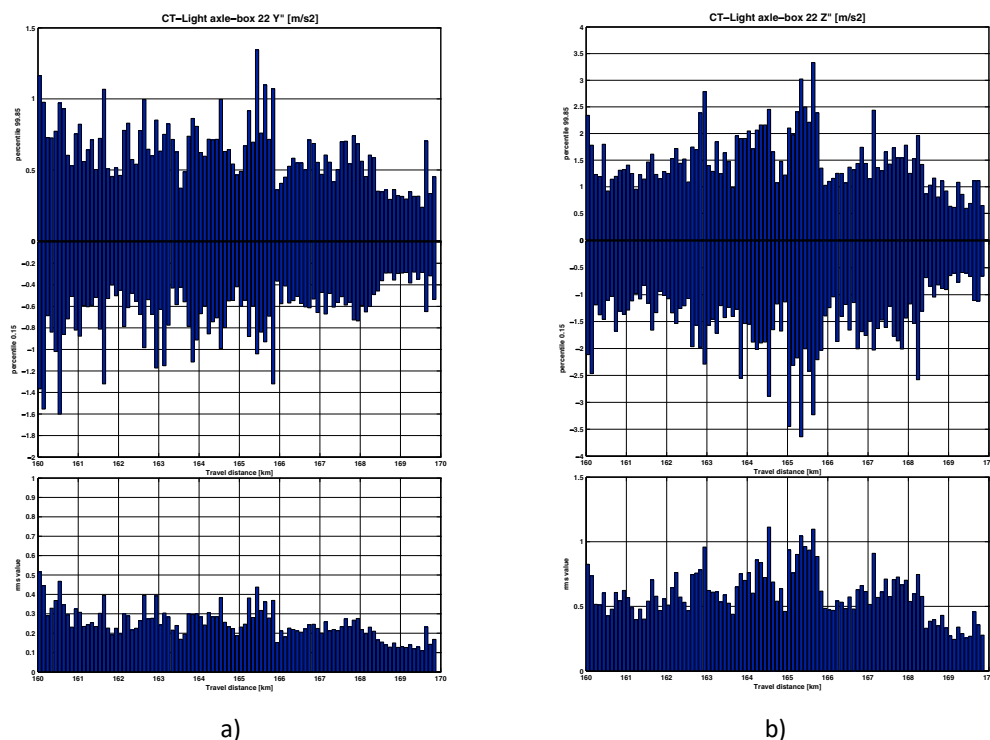

Fig. 14: Percentiles (0.15% and 99.85%) and r.m.s. values of the axle-box 22 lateral (a) and vertical (b) accelerations measured on the “traditional” Gotthard tunnel on the CTLIGHT vehicle running at about 90 km/h.

5. Conclusion

The paper deals with the assessment of the track quality of the new Gotthard Base tunnel with respect to the traditional line. Analyses have been performed by equipping two freight cars with the monitoring system conceived by the Authors and several values of the vehicle speed and axle load have been investigated.

The results show that the new tunnel is able to ensure better performances than the traditional one also for higher vehicle speed. The experimental tests have shown that the accelerations measured on the two tracks and considering the same vehicle are lower on the Base tunnel also when the vehicle is running at higher speed. With the new Base tunnel will be then possible to reduce the travel time and increasing the vehicle performances in terms of impact on the line.

Acknowledgements

The Monitoring Board adopted in this paper was developed during the NPTC project funded by the Piedmont Region. The Authors thank SBB and Hupac S.A for the availability of the wagons and the possibility of participating in the tests.

References

- Alemi, A., Corman, F., Lodewijks, G. 2017. Condition monitoring approaches for the detection of railway wheel defects. Proceedings of the Institution of Mechanical Engineers, Part F: Journal of Rail and Rapid Transit 231(8), pp. 961-981
- Bosso, N., Gugliotta, A., Somà, A., 2002. Multibody simulation of a freight bogie with friction dampers, ASME/IEEE 2002 Joint Rail Conference, RTD 2002, pp. 47-56. ISBN: 0791835936; 978-079183593-7, doi: 10.1115/RTD2002-1642
- Bosso, N., Gugliotta, A., Zampieri, N., 2018. Different dynamic track excitations on freight vehicles running on high speed and traditional lines detected with onboard diagnostic systems, 25th Symposium of the International Association of Vehicle System Dynamics, IAVSD 2017, Rockhampton; Australia, The Dynamics of Vehicles on Roads and Tracks Volume 2, 2018, Pages 867-872.
- Bosso, N., Gugliotta, A., Zampieri, N., 2018. Wheel flat detection algorithm for onboard diagnostic, Measurement: Journal of the International Measurement Confederation, 123, pp. 193-202. doi: 10.1016/j.measurement.2018.03.072.
- Bosso, N., Gugliotta, A., Zampieri, N., 2018. Design and testing of an innovative monitoring system for railway vehicles, Proceedings of the Institution of Mechanical Engineers, Part F: Journal of Rail and Rapid Transit, 232 (2), pp. 445-460. doi: 10.1177/0954409716675005

- Brignole, O., Cavalletti, C., Maresca, A., (...), Testa, A., Vitelli, M. 2016. Resonant electromagnetic vibration harvesters feeding sensor nodes for real-time diagnostics and monitoring in railway vehicles for goods transportation: A numerical-experimental analysis, Proceedings - 2016 IEEE International Power Electronics and Motion Control Conference, PEMC 2016
- Kalaagi, M., Seetharamdo, D. 2019. Electromagnetic Energy Harvesting Systems in the Railway Environment: State of the Art and Proposal of a Novel Metamaterial Energy Harvester, 13th European Conference on Antennas and Propagation, EuCAP 2019.
- Kuře, G., Schmiechen, R., 2010, Solutions for railway bogie condition monitoring, SKF Evolution magazine, 1, pp. 25–27.
- Li, C., Luo, S., Cole, C., Spiriyagin, M. 2017. An overview: Modern techniques for railway vehicle on-board health monitoring systems. *Vehicle System Dynamics* 55(7), pp. 1045-1070.
- Liu, Y., Qian, Q., Liu, F., Lu, S., Fu, Y. 2017. Wayside acoustic fault diagnosis of train wheel bearing based on Doppler effect correction and fault-relevant information enhancement. *Advances in Mechanical Engineering* 9(11)
- Montalvo, J., Tarawneh, C., Fuentes, A.A. 2018. Vibration-based defect detection for freight railcar tapered-roller bearings. Joint Rail Conference, JRC 2018
- Pan, Y., Liu, F., Jiang, R., Tu, Z., Zuo, L. 2019. Modeling and onboard test of an electromagnetic energy harvester for railway cars, *Applied Energy*, pp. 568-581.
- Sneed, W.H., Smith, R.L. 1998. On-board real-time railroad bearing defect detection and monitoring, Proceedings of the 1998 ASME/IEEE Joint Rail Conference.
- Tarawneh, C., Aranda, J.A., Hernandez, V.V., Ramirez, C.J. 2018. An analysis of the efficacy of wayside hot-box detector data. Joint Rail Conference, JRC 2018.
- Tournay, H., Walker, R., Chapman, S., 2007. Inspection and Maintenance of Poorly Performing Cars Identified by Hunting Detectors, Technology Digest TD07-005, AAR, TTCI, Pueblo, CO, USA.
- Zampieri, N., Bosso, N., Gugliotta, A., 2016. Innovative monitoring systems for onboard vehicle diagnostics, *Civil-Comp Proceedings* Volume 110, 2016.
- Zhong, Y., Gao, X., Peng, J., Luo, L., Liu, Z. 2017. Detection and analysis of key component of train's locomotive based on image analysis techniques. Proceedings of 2016 IEEE International Wheelset Congress, IWC 2016, pp. 135-140