

PRELIMINARY STRUCTURAL ANALYSIS OF AN ACTIVE EXOSKELETON FOR ROBOTIC NEURO-REHABILITATION

*Original*

PRELIMINARY STRUCTURAL ANALYSIS OF AN ACTIVE EXOSKELETON FOR ROBOTIC NEURO-REHABILITATION / Belforte, Guido; Raparelli, Terenziano; Eula, Gabriella; Pietrafesa, FRANCESCO GIUSEPPE; Sirolli, Silvia; Carlo Geminiani, Giuliano; Geda, Elisabetta; Zettin, Marina; Virgilio, Roberta; Sacco, Katuscia. - In: INTERNATIONAL JOURNAL OF MECHATRONICS AND APPLIED MECHANICS. - ISSN 2559-6497. - ELETTRONICO. - 1:8(2020), pp. 33-39.

*Availability:*

This version is available at: 11583/2854866 since: 2020-12-05T17:10:11Z

*Publisher:*

CEFIN

*Published*

DOI:

*Terms of use:*

openAccess

This article is made available under terms and conditions as specified in the corresponding bibliographic description in the repository

*Publisher copyright*

(Article begins on next page)

# PRELIMINARY STRUCTURAL ANALYSIS OF AN ACTIVE EXOSKELETON FOR ROBOTIC NEURO-REHABILITATION

Guido Belforte<sup>1\*2</sup>, Terenziano Raparelli<sup>1</sup>, Gabriella Eula<sup>1</sup>, Francesco Giuseppe Pietrafesa<sup>1</sup>,  
Silvia Sirolli<sup>2</sup>, Giuliano Carlo Geminiani<sup>3,4</sup>, Elisabetta Geda<sup>5</sup>, Marina Zettin<sup>3,6</sup>, Roberta Virgilio<sup>6</sup>, Katuscia Sacco<sup>3,4</sup>

<sup>1\*</sup>Former of Department of Mechanical and Aerospace Engineering, Politecnico di Torino, Torino, 10129, Italy

<sup>1</sup>Department of Mechanical and Aerospace Engineering, Politecnico di Torino, Torino, 10129, Italy

<sup>2</sup>NIMBLE ROBOTICS<sup>®</sup> - Spin Off of Politecnico di Torino, Torino, 10100, Italy

<sup>3</sup>Brain Plasticity and Behaviour Changes Research Group, Department of Psychology,  
University of Turin, Torino, 10100, Italy

<sup>4</sup>Neuroscience Institute of Torino, Torino, 10100, Italy

<sup>5</sup>Istituto Delle Riabilitazioni Riba-IRR, Torino, 10100, Italy

<sup>6</sup>Puzzle Rehabilitation Center for Brain Injury, Torino, 10100, Italy

Emails: [guido.belforte@formerfaculty.polito.it](mailto:guido.belforte@formerfaculty.polito.it), [terenziano.raparelli@polito.it](mailto:terenziano.raparelli@polito.it), [gabriella.eula@polito.it](mailto:gabriella.eula@polito.it),  
[francesco.pietrafesa@polito.it](mailto:francesco.pietrafesa@polito.it), [silvia.sirolli@nimblerobotics.com](mailto:silvia.sirolli@nimblerobotics.com), [giulianocarlo.geminiani@unito.it](mailto:giulianocarlo.geminiani@unito.it) (G.C.G.),  
[geda@irriba.it](mailto:geda@irriba.it), [marina.zettin@unito.it](mailto:marina.zettin@unito.it), [r.virgilio@centropuzzle.it](mailto:r.virgilio@centropuzzle.it), [katuscia.sacco@unito.it](mailto:katuscia.sacco@unito.it) (K.S.)

---

**Abstract** – In this paper the exoskeleton P.I.G.R.O. (Pneumatic Interactive Gait Rehabilitation Orthosis), developed in the Department of Mechanical and Aerospace Engineering (DIMEAS) Politecnico di Torino with the important co-operation with doctors, is presented. It was preliminary designed for a completely unloaded walking gait cycle in order to treat the first steps of the neuro-rehabilitation trainings. An initial FEM evaluation of P.I.G.R.O. structure is here presented. It underlines a lot of important aspects and techniques to analyse the structural characteristics of P.I.G.R.O. legs rigid parts using a commercial software but analysing both the actions of the pneumatic actuators and of the patients muscles and/or movements. The results obtained are good and allow to verify the P.I.G.R.O. legs structure and to establish a procedure to study its characteristics also with the presence of the patient.

**Keywords:** FEM analysis of an Active Exoskeleton, Design of an electro-pneumatically controlled Exoskeleton for Neuro-Rehabilitation Training, Structural Study of an Active Exoskeleton worned by the patient, Robotic Neuro-Rehabilitation Device, FEM considerations about an Electro-Pneumatic Exoskeleton worned by a patient, Active Exoskeleton suitable for Neuro-Rehabilitation Training.

---

## 1. Introduction

An exoskeleton, in general, is an electro-pneumatic device often with an electro-pneumatic control, wearable by the subject (healthy subject or not) useful for specific operations [11],[2],[12],[16].

For example an exoskeleton is capable to increase the muscle force of a healthy subject or it can help a patient to do some movements, both for daily assistance and for rehabilitation purposes.

An exoskeleton works in parallel with the human body of the subject that wears it and it can be an active or a passive exoskeleton.

In general the advantages in the use of an exoskeleton are [13],[1]: the possibility to impose the movements with continuity and regularity; the possibility to measure a lot of parameters during its use, as it can have various kinds of sensors; the possibility to help the physiotherapist in his work during the rehabilitation training; the possibility to

do easier the human muscles work in some industrial operations.

Sometimes the control of the exoskeleton is an electro-pneumatic control [10], using standard pneumatic actuators or pneumatic muscles [9],[15].

The advantages of an electro-pneumatic control are: the possibility to regulate easily the force imposed on the human limbs during the training with the exoskeleton, for example reducing the pressure in the pneumatic actuators; the useful effect of the variable stiffness of the air, giving comfort and safe to the subject; the use of an energy source clean and safe, suitable for hospital environments; the possibility to have an actuation not sensible to electro-magnetic interferences and suitable to be used also outside from the rehabilitation centers.

In this paper the exoskeleton P.I.G.R.O. (Pneumatic Interactive Gait Rehabilitation Orthosis) is presented. It was fully developed in the DIMEAS

(Department of Mechanical and Aerospace Engineering) of Politecnico di Torino (Italy) together with an equip of doctors of the University of Torino, Department of Phycology and Puzzle Center for brain strokes (Torino, Italy).

In June 2015 P.I.G.R.O. was selected among the best five more interesting projects in the Soft-landing Programme, APAC Innovation Summit 2015 Series—Robotics—Hong Kong, 22–27 June 2015.

In June 2017, during the 26th International Conference on Robotics in Alpe-Adria-Danube Region, RAAD2017, the authors received the Gold Best Application Paper Award [3].

In these years P.I.G.R.O. became a Patent of the Politecnico di Torino ("Active orthosis for the motion neurological rehabilitation of lower limbs, system comprising such orthosis and process for operating

such system", G.Belforte, G.Eula, S.Appendino, G.C.Geminiani, M.Zettin, Patent EP 2 825 146 B1, March 2012) [17],[4] and in May 2017 a spin-off for the industrialisation of this prototype started up.

## 2. P.I.G.R.O. Characteristics

The study and the design of the active exoskeleton P.I.G.R.O. was carried out by the Research Group of Prof. Guido Belforte ("Doctor Honoris Causa" of the Universitatea Politehnica din Bucuresti Romania) together with a doctors equip.

The prototype P.I.G.R.O. here presented was designed for rehabilitation training with the patient fully unloaded, suspended to a Body Weight Support, where the same exoskeleton is then suspended too (Figure 1)[14],[5].

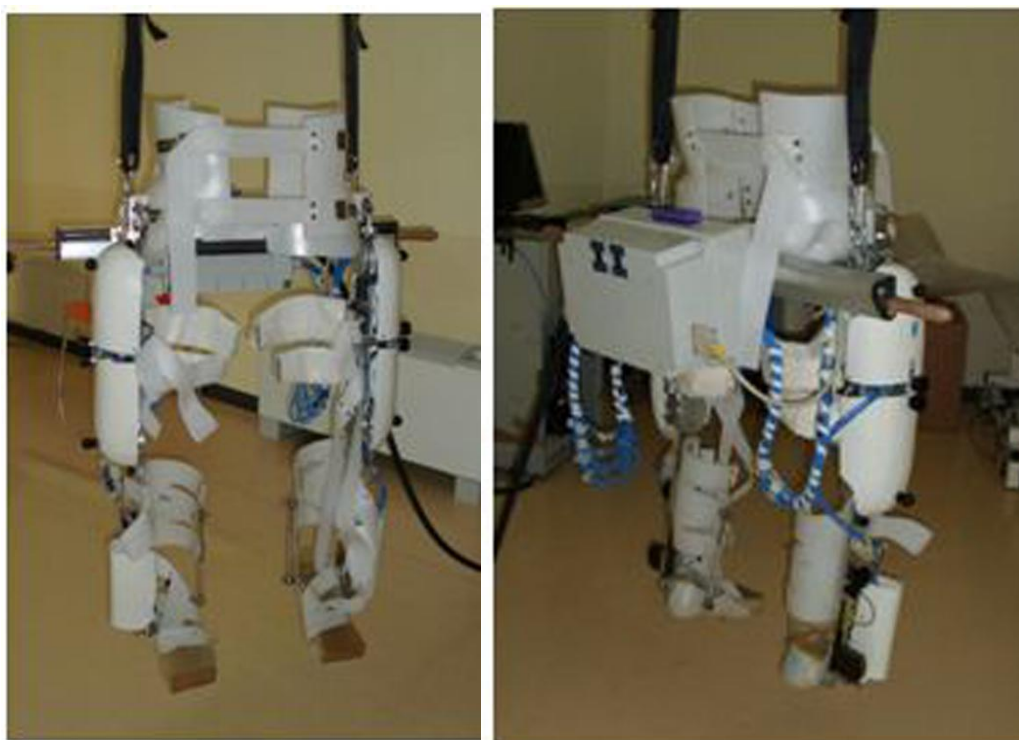

*Figure 1: The exoskeleton P.I.G.R.O. and its control box on board*

P.I.G.R.O. allows the movements of the patient's lower limbs in the sagittal plane.

The rigid parts making of the legs of P.I.G.R.O. are constructed in C72 steel and in Aluminium 7075 (Ergal) to allow to the patient that wears this exoskeleton to do some little movements in the frontal plane too during the rehabilitation training with the patient fully unloaded.

As the length of the femur and of the tibia is adjustable in order to adapt the exoskeleton to the anthropometric dimensions of the subject, the rigid parts of the legs of P.I.G.R.O. (femoral parts and tibia parts) are built in two parts capable of moving each other giving an adjustable length between the hip and the knee joint and the knee and the ankle joint.

This is a manual regulation and some parts of Turcite were interposed between the two movable elements in order to reduce the friction effects.

P.I.G.R.O. has a rear adjustable handle (Figure 2).

As it is shown in the Figure 2b, the handle has: a cover (1), two rigid bars (2) and (4), the screws (3).

The handle geometry was defined after several studies on various configurations and gives a system that: allows a wide pelvis width regulation, gives a strong support for the P.I.G.R.O. legs, provides two lateral supports through which the therapist can stabilize during the training the patient's vertical position.

This regulation is obtained using two electric motors.

The Range Of Movement (R.O.M.) in P.I.G.R.O. are: hip joint from  $-20^{\circ}$  to  $+20^{\circ}$ ; knee joint from  $60^{\circ}$  to  $0^{\circ}$ ; ankle joint from  $-25^{\circ}$  to  $25^{\circ}$ . In particular the ankle R.O.M. is more than the physiological one (standard walking on the ground) as in this way the motor cortex stimulation during the unloaded walking can be increased.

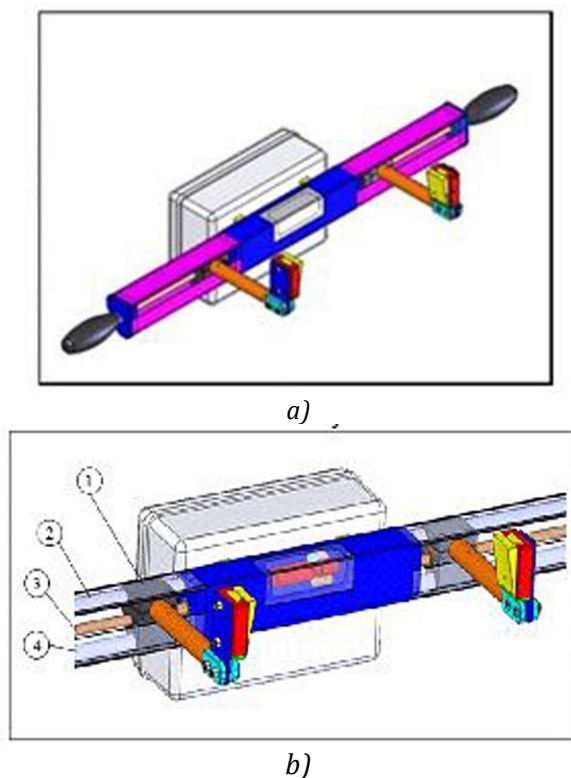

Figure 2: Some details of the rear handle and its motorized system

The anthropometric regulations in P.I.G.R.O. [6],[7] are from the 10%ile Italian woman to the 95%ile Italian man, with a pelvic width regulation from 300 mm in the 10%ile Italian woman to 650 mm in the 95%ile Italian man. The femur length can be varied from 370 mm to 500 mm, the tibia length from 360 mm to 500 mm, always referring to the 10%ile Italian woman to the 95%ile Italian man.

In P.I.G.R.O. these anthropometric regulations are manually carried out before the start of the rehabilitation training.

The pneumatic cylinders of P.I.G.R.O. are: hip joint bore 40 mm, stroke 24 mm; knee joint bore 40 mm, stroke 35 mm; ankle joint bore 32 mm, stroke 40 mm.

Using a pressure of 6 bar ( $6 \times 10^5$  Pa) the torques in the joints are: hip joint 45 Nm; knee joint 45 Nm; ankle joint 25 Nm. These values are proper for the fully unloaded walking.

The electro-pneumatic control of P.I.G.R.O. uses 32 electro-pneumatic valves 2/2 to control the pneumatic actuators.

In the fixed control box there are two electronic pressure regulators that allows to regulate separately the pressure in the two legs of P.I.G.R.O.

On the hip joint and on the knee joint the pneumatic actuators are fixed with the principle the agonistic-antagonistic muscle, as this configuration allows to reduce the encumbrance and the dimensions of the cylinders required. In the Figure 3 some details are shown.

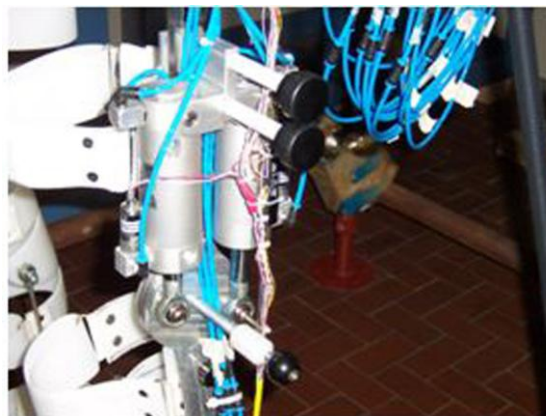

Figure 3: Details of the pneumatic actuators fixed with the principle of the agonistic-antagonistic muscle (knee joint)

Thanks to a proper electro-pneumatic control system, put in the box on board and in the fixed box, it is possible, if it is required, to impose two different pressures in the two legs of P.I.G.R.O.. This is useful in the case of treatments with patients having an asymmetrical condition in the two legs.

These pressures are adjustable from the control software of P.I.G.R.O. and they can be read on two manometers put in the frontal panel of the fixed box (Figure 4).



Figure 4: Pressure manometers in the fixed box used to set and to read the pressure in the two legs of P.I.G.R.O.

The software of P.I.G.R.O. allows to control the exoskeleton, to manage the rehabilitation training (with a lot of options required by the doctors), to save the data.

The authors also studied and realised an innovative and efficient patient harness system, useful to suspend the patient to the Body Weight Support. Using this harness system the patient can be suspended for 1 h without any pain, with the legs in a vertical position and free in the movement.

Carrying out specific tests on a fully unloaded walking conditions, authors studied and defined innovative control curves proper for the unloaded gait cycle [8].

Furthermore a lot of tests were carried out [3],[17],[4],[14],[5] in order to: design and realise a specific electro-pneumatic control system; obtain proper anthropometric regulations and wide R.O.M. (Range Of Movement) on each joint; select the best pneumatic actuators capable to give the required torques; study and define specific curves for the unloaded walking [8]; analyse the main structural characteristics of the construction of the P.I.G.R.O. legs.

In particular this paper presents some results of a FEM analysis on a P.I.G.R.O. leg under the forces give by the pneumatic actuators and by the patient. This analysis is important in order to analyse the geometry, the characteristics and the safety of the structure making the leg of P.I.G.R.O.

### 3. Some Results from a FEM Analysis on a Leg of P.I.G.R.O.

Using a specific commercial software, some structural evaluations were carried out.

This FEM analysis on P.I.G.R.O. was carried out on a single leg, in order to use an easier geometry for the simulation and to reduce the time calculation.

The analysis was carried out placing a locking (green arrow-shaped objects in Figures 5 and 6) close to the hip joint, where P.I.G.R.O. leg is connected to the rear handle.

Figure 5 show the details of the: locking, thigh support, load a), femur, calf support, load b).

Here the thigh and the calf supports were only used to schematize the application of the loads due to the patient.

In fact the loads on P.I.G.R.O. leg structure are from the pneumatic cylinders and from the patient's autonomous movement.

In particular the torques on P.I.G.R.O. joints are equal to the values here above mentioned for that maximum supply pressure.

The loads used to do the simulation were equal to the maximum forces that the actuators can generate.

The FEM simulation was also carried out considering a mass of the patient's leg equal to 25 kg.

The stresses due to the patient's movement are both in the sagittal plane and in the frontal plane, during the unloaded gait cycle.

The little movements in the frontal plane generate a lateral deformation on P.I.G.R.O. leg.

The simulation was carried out with the load a) and then with the load b) and finally with the two loads applied together.

The load a) and the load b) are shown in Figure 5.

In particular the load a) simulates the forces generated by the patient during the unloaded gait cycle (equal to 200 N during the simulation, distributed on the element that here simulates the femur).

The load b) considers some lateral forces imposed by the patient to the P.I.G.R.O. leg structure during the unloaded walking.

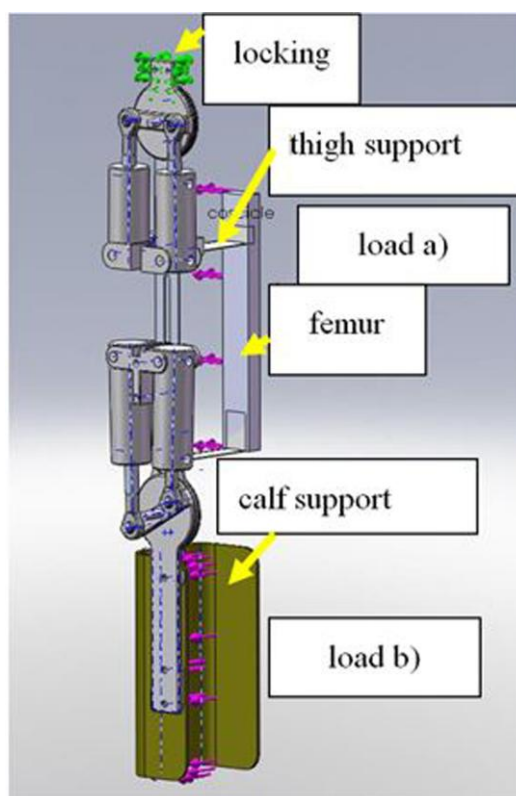

Figure 5: P.I.G.R.O leg details and structure used for the simulation

Applying a load generating a lateral deformation, a lateral displacement of the P.I.G.R.O. leg structure in the end of the model here presented about 132 mm (and 180 mm where there is the patient's foot) was evaluated.

This allows to consider a deformation stronger than a real possible one.

The patient's opposition to the movement guided by the exoskeleton can be due to the weight of the patient's leg, to some random stiffening arising in the patient's muscles during the training, to the muscles forces generating by the patient when he was doing the gait cycle.

All of these forces together cannot generate an action higher than the pneumatic actuators one, when the patient is fully guided by the exoskeleton.

From these simulations some maximum stress values, equal to 450 MPa on the spring steel material (yield strength load equal to 1000 MPa), were verified.

A study applying both load a) and load b) together was also carried out. In this case the maximum stresses were also verified in the parts in spring steel material, but, in any case, they are about the 50% of the maximum values allowed by the material.

The area of the locking (close to the rear handle of P.I.G.R.O.) was also verified and this analysis gave a positive result too.

Due to the flexibility of the structure here considered, the software shows sometimes a saturation condition in solving the analysis. So the values both of load a) and load b) are divided by a constant value and the results obtained have then to be multiplied by 10.

In the Figures 6a) and b) the violet arrow-shaped objects simulate the forces generated by the patient's in the sagittal plane.

In these cases the parts in spring steel are very stressed but in any case the tensions are under the yield strength load of the material.

In the Figure 6a the patient's leg applies to P.I.G.R.O. leg structure some forces in the sagittal plane (violet arrow-shaped objects).

It can be seen that the parts in spring steel material are more stressed.

The Figure 6b) shows the lateral displacement in the P.I.G.R.O. leg during the functioning of the exoskeleton under some forces oriented as shown in the Figure.

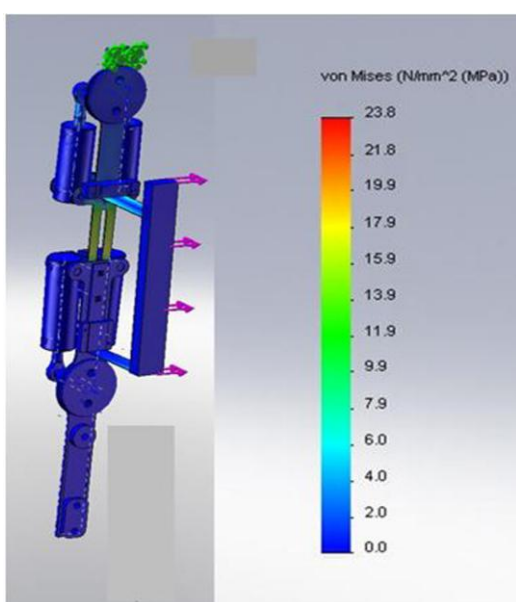

Figure 6 a): Von Mises tensions

In particular Figure 6b) shows the displacement under the lateral force applied in the patient's calf area, while Figure 6c) shows the displacement under the loads a) and b) applied together and under of the forces due to the patient's step gait cycle. Figure 6d) shows the equivalent tension under some lateral forces. In this case during the simulation a deformation was imposed and then the resistance of the material more stressed (that is the part in spring steel) was verified.

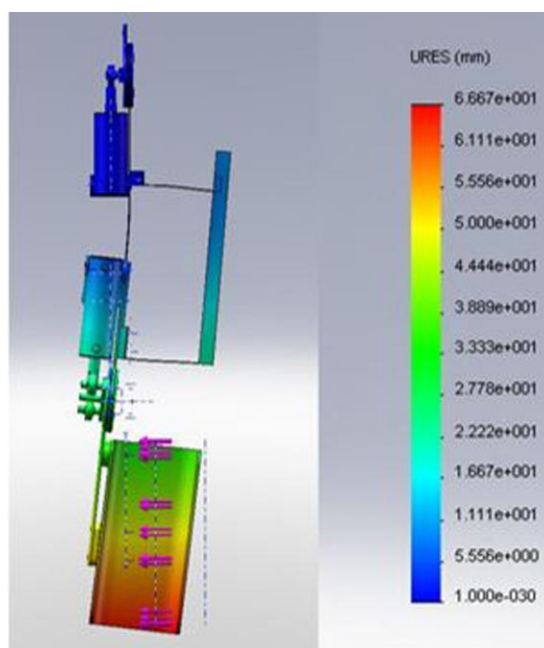

Figure 6 b): Static displacement under lateral forces applied in the tibia area

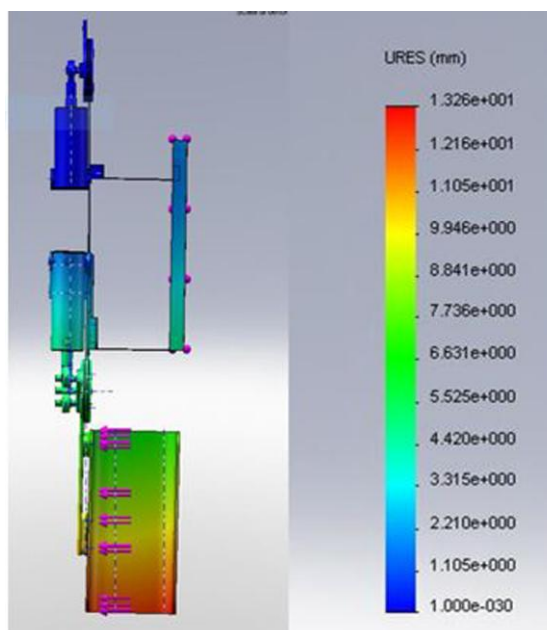

Figure 6c): Static displacement under the action of the loads a) and b) applied together and under the action of the forces generated by the patient during the gait cycle

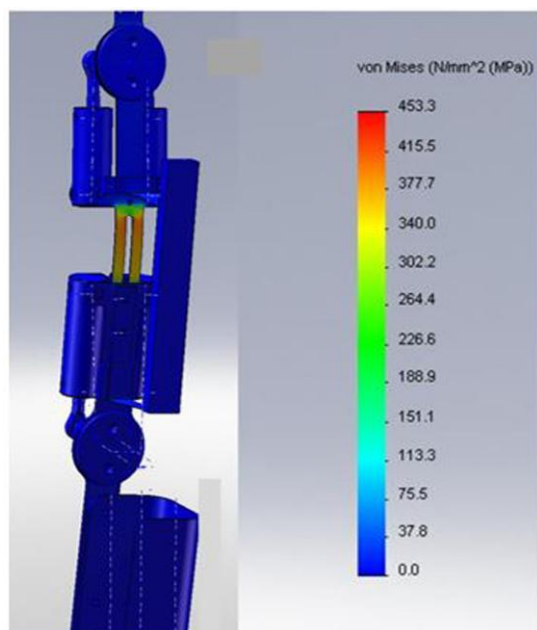

Figure 6d): Von Mises tensions with lateral deformation

Figure 6: Some results from FEM simulation (a) Von Mises tensions; b) Static displacement; c) Static displacement; d) Von Mises tensions with lateral deformation

The FEM analysis here presented is useful to establish a method to verify the exoskeleton structure when it is under the forces given by the pneumatic actuators and by the patient. In any case the study gives a good model of the leg of the exoskeleton in a CAD software and FEM analysed.

The results obtained are good and show the efficiency of the materials selected for the rigid parts of P.I.G.R.O. legs, the proper configuration of the pneumatic cylinders, fixed with the principle of the agonistic-antagonistic muscles, a method to study the presence of the patient wearing the exoskeleton.

#### 4. Conclusions

This paper shows the main characteristics of the active exoskeleton P.I.G.R.O. having an electro-pneumatic control.

In particular it is here presented a preliminary FEM analysis of a leg of the exoskeleton. Using this analysis the characteristics of stress and deformation were verified during the use of the exoskeleton with the patient fully unloaded and with this configuration of the pneumatic actuators.

The results obtained are good and show the safety of the device.

#### Acknowledgements (not mandatory)

The work presented in this paper was financed, with funding from the Compagnia di San Paolo project, "Active exoskeleton for the functional gait rehabilitation of paretic patients", and with funding

from the Piedmont regional administration project, entitled "Validation of a method for gait rehabilitation for paretic patients using an active orthosis" (2006–2008).

#### References

- [1] Anam K., Al-Jumaily A.A., "Active exoskeleton control systems: state of the art", Int. Symposium on Robotics and Intelligent Sensors, Procedia Engineering 41, pp. 988-994 (2012).
- [2] Dollar A.M, Herr H., "Active orthoses for the lower-limbs: Challenges and state of the art", Proceedings of the 2007 IEEE 10th International Conference on Rehabilitation Robotics, June 12-15, Noordwijk, The Netherlands, 1-4244-1320-2007 IEEE, pp. 968-977 (2007).
- [3] Sacco K, Belforte G., Eula G., Raparelli T., Sirolli S., Geda E., Geminiani G.C, Virgilio R. and Zettin M., "P.I.G.R.O.: An active exoskeleton for robotic neurorehabilitation training driven by an electro-pneumatic control", Proceedings of the 26th International Conference on Robotics in Alpe-Adria-Danube Region RAAD2017, Politecnico di Torino, Torino, Italy, Advances in Service and Industrial Robotics, Mechanisms and Machine Science, Vol. 49, pp. 845-853 (2017).
- [4] Belforte G., Eula G., Appendino S., Geminiani G.C. and Zettin M., "Active orthosis for the motion neurological rehabilitation of lower limbs, system comprising such orthosis and process for operating such system", European Patent EP2825146 B1 (2018).
- [5] Sacco K, Cauda F., Duca S., Belforte G., Eula G., Gastaldi L., Appendino S., Zettin M., Virgilio R., Nascimbeni A. and Geminiani G., "A combined robotic and cognitive training for locomotor rehabilitation: evidences of cerebral functional reorganization in two chronic traumatic brain injured patients", Frontiers in Human Neuroscience, Vol.1, pp.1-44 (2011). doi: 10.3389/fnhum.2011.00146.
- [6] UNI EN ISO 7250-1:2010: Basic human body measurements for technological design — Part 1: Body measurement definitions and landmarks.
- [7] UNI EN ISO/TR 7250-2:2011: Basic human body measurements for technological design — Part 2: Statistical summaries of body measurements from individual ISO populations.
- [8] Belforte G., Eula G., Sirolli S., Appendino S., Geda E., Geminiani G., Zettin M., Virgilio R. and Sacco K., "Control curves for a new lower limbs robotic exoskeleton obtained from the study of joints angles during an unloaded human walking", International Journal of Mechanics and Control, Vol. 18, No. 1, pp. 3-14 (2017).
- [9] Belforte G., Eula G., Appendino S., "Design and development of innovative textile pneumatic muscles", The Journal of the Textile Institute,

- iFirst, pp. 1-11 (2011). doi: 10.1080/00405000.2011.603508.
- [10] Dzahir M.A.M., Yamamoto S.I., "Design and evaluation of the AIRGAIT Exoskeleton: leg orthosis control for assistive gait rehabilitation", *Journal of Robotics - Rehabilitation Robotics (special issue)*, Hindawu Publ. Corporation, Vol. 2013, pp. 1-20 (2013).
- [11] Riener R., Lunenburger L., Colombo G., "Human-centered robotics applied to gait training and assessment", *J. Rehabil. Res. Dev.* 2006, 43: pp. 679-694. doi: 10.1682/JRRD.2005.02.0046.
- [12] Wolbrecht E.T., Chan V., Reinkensmeyer D.J., Bobrow J.E., "Optimizing compliant, model-base robotic assistance to promote neurorehabilitation", *IEEE Trans. Neural Syst. Rehabil. Eng.* 2008, 16: pp. 286-297. doi:10.1109/tnsre.2008.918389.
- [13] Koceska N., Koceski S., Beomonte Zobel P., Durante F., "Pneumatically actuated exoskeleton for gait rehabilitation", *Proceedings of the 8th JFPS Int. Symp. On Fluid Power, OKINAWA 2011*, October 25-28, pp. 43-50 (2011).
- [14] Belforte G., Eula G., Appendino S. and Sirolli S., "Pneumatic Interactive Gait Rehabilitation Orthosis: Design and Preliminary Testing. Proceedings of the Institution of Mechanical Engineers", Part H: *Journal of Engineering in Medicine*, Vol. 225, No.2, pp. 158-169 (2011).
- [15] Belforte G., Eula G., Ivanov A., Raparelli T., Sirolli S., "Presentation of textile pneumatic muscle prototypes applied in an upper limb active suit experimental model", *The Journal of The Textile Institute*, pp. 1-10 (2017). <https://doi.org/10.1080/00405000.2017.1368111>.
- [16] Roy A., Krebs H.I., Williams D.J., Bever C.T., Forrester L.W., Macko R.M., Hogan N., "Robot-aided neurorehabilitation: A novel robot for ankle rehabilitation", *IEEE Trans. Robot.* 2009; 25: pp. 569-582. doi: 10.1109/TRO.2009.2019783.
- [17] Belforte G., Eula G., Appendino S., Geminiani G.C. and Zettin M., "Tutore attivo per neuroriabilitazione motoria degli arti inferiori, sistema comprendente tale tutore e procedimento per il funzionamento di tale Sistema", Patent n. TO2012A000226 (2012).