

The importance of accurate battery models for power assessment in smart energy systems

Original

The importance of accurate battery models for power assessment in smart energy systems / Chen, Yukai; Vinco, Sara. - ELETTRONICO. - (2020), pp. 44-49. ((Intervento presentato al convegno The Tenth International Conference on Smart Grids, Green Communications and IT Energy-aware Technologies tenutosi a Lisbon (Portugal) nel September 27, 2020 to October 01, 2020.

Availability:

This version is available at: 11583/2847012 since: 2020-09-29T14:33:11Z

Publisher:

IARIA

Published

DOI:

Terms of use:

openAccess

This article is made available under terms and conditions as specified in the corresponding bibliographic description in the repository

Publisher copyright

(Article begins on next page)

The Importance of Accurate Battery Models for Power Assessment in Smart Energy Systems

Yukai Chen, Sara Vinco

Department of Control and Computer Engineering, Politecnico di Torino
Corso Duca degli Abruzzi, 24, 10129 Torino, Italy
Email: yukai.chen@polito.it, sara.vinco@polito.it

Abstract—The smart energy system is characterized by a broader combination of various energy sources and energy storage devices with smart control management and increased attention to optimization for increasing energy efficiency. The fundamental dimension in the smart energy system design is the power assessment of the possible design architecture. This demand imposes a need for accurately tracking the system’s power flow, simulating and validating the system’s behavior, and applying additional optimization and exploration during the design time. Thus, it is evident that simulation is a critical step in the design flow of a smart energy system. One essential element to enable such accurate simulation is the precise model of the power generation and consumption. While sophisticated models for energy sources exist, the power flow in the system does not perfectly match the power drawn from the energy storage devices because the battery, as the primary energy storage device in the smart energy system, has non-ideal discharge characteristics. We propose adopting an elaborate battery model for the smart energy system’s accurate power assessment in this work. We show the importance of battery model accuracy when conducting a power assessment using two different case studies.

Keywords—Power Modeling and Simulation; Battery Modeling; Smart Energy System; Design Time Optimization; Energy Optimization.

I. INTRODUCTION

The smart energy system contains different scales of energy systems executed by the smart control management policy. It covers applications from watts to kilowatts levels, from small-scale Internet of Things (IoT) nodes to large-scale smart grid applications. High energy efficiency is a critical requirement for the small-scale smart energy systems since they only have a small-size energy storage device and power source component. Some of them even do not install the power source component. A typical small-scale example is a battery-powered IoT sensor node. Maximizing this kind of sensor node’s lifetime is critical during the design time since the nodes are distributed in a very dispersed manner and the cost of replacement is very high. For large-scale smart energy systems, the adoption of green power sources and energy storage devices is considered a promising solution to reduce the impact on the environment and save users’ costs. Therefore, these kinds of large-scale smart energy systems need a careful design to overcome the oscillating nature of the harvested environmental quantities and the users’ undisciplined power consumption to achieve an optimal balance between power generation and consumption.

To improve the smart energy system’s energy efficiency, the designer must assess the system’s real-time power flow during the design time using computer-aided modeling and simulation tools. The traditional approach in the academic and industry fields to designing a smart energy system relies on a model-

based methodology that depends on existing models provided by commercial simulation tools like Matlab/Simulink. Commercial tools have enhanced features and functionalities, and they are ordinarily user-friendly. Still, there are several limitations of the commercial tools: (1) it is hard to extend them as proprietary tools; (2) it is difficult to extend the performance of the built-in classic models to generate more accurate results; (3) commercial tools are not designed for efficiently and simultaneously simulating the physical portion (usually continuous-time) and the cyber portion (usually discrete-time) of the systems, while these two portions are the intrinsic features coexisting in the smart energy system; and (4) a smart energy system is a typical heterogeneous system composed of various components, with different parts possibly needing different models of computations in the simulation; commercial tools and platforms lack this kind of heterogeneous modeling and simulation support.

To tackle these limitations, several methodologies have been proposed in the literature that borrowed the existing approaches from the domain of electronic system design. One common feature shared by these solutions is building a database filled with pre-characterized models of the system’s various components. This feature does allow the designer to select a model of an element from the pre-defined model database by assuming a given level of abstraction and a given semantics of the model. It speeds up modeling the whole smart energy system; however, one critical issue is ignored during the power assessment. The smart energy system is typically composed of three main categories: power source components, energy storage components, and power consumption components. When the battery plays the power source role in the system, the power consumed by the load does not have a perfect 1:1 match with the power provided from the battery, as it is not an ideal electric device. The reason for the mismatch is that the actual power delivered by the battery depends on its current State Of Charge (SOC), the current magnitude, and the load frequency. More specifically, the higher the current amplitude and load frequency, the more power is being consumed from the battery. Hence, under the same conditions, a larger discharge current or high-frequency discharge current profile will consume more battery capacity.

To address this issue, in this paper, we propose to incorporate one circuit equivalent battery model, which has SOC and dynamic current dependency characteristics, in the power simulation of a smart energy system. We adopt an elaborated battery model to simulate the smart energy system for tracking accurate real-time power flow in the system. Two case studies relative to different smart energy system scales are simulated in our work to illustrate the importance of an accurate battery

model for power/energy assessment in various smart energy system applications.

The rest of the paper is organized as follows. Section II provides the required background and the motivation of this work; Section III describes the battery model adopted in our work; Section IV reports the simulation framework used in our experiments; Section V shows two case studies to indicate our proposal; finally, Section VI concludes the paper.

II. BACKGROUND AND MOTIVATION

A large number of research activities are currently devoted to optimizing energy efficiency in the smart energy system. A high energy-efficient design relies on an accurate power/energy analysis, and modeling and simulation of the smart energy system are using widely approved techniques to conduct power/energy assessment during the early design time. Several approaches for modeling and simulation of smart energy systems have been proposed in the literature to address different application contexts, ranging from general-purpose electrical energy systems [1], small-scale IoT devices [2], large-scale system like smart grids [3], and medium-scale systems as Electric Vehicles (EV) [4]. Several different popular simulation approaches are introduced in the following paragraphs.

Hardware-in-the-loop approaches mix software simulated models with sensors and actuators or integrate power electronic devices such as inverters to test the combination of new technology in a controlled environment [5]. The resulting accuracy is higher than software simulation, but applications are restricted to small- and medium-scale smart energy systems. Proprietary tools, such as Simulink, are usually considered the de-facto standard. However, they are proprietary tools, thus not easily extensible and accessible. The designer can choose among several predefined components or instead implement his/her designs by relying on the provided libraries, which restricts the chances of developing custom component libraries and evaluating alternative models. Equation-based approaches, such as Modelica, decompose the system into elementary components, modeled with fundamental physics equations, or with predefined models [6]. This method restricts the kind of descriptions supported by each simulation infrastructure. It does not allow designers to model the cyber portion of a smart energy system effectively. Co-simulation approaches simulate specific aspects of the energy systems in their native environment, combined with other tools to estimate, e.g., the impact of network latency on control policies or the application of electricity rates [7]. This co-simulating mechanism leads to a very time-demanding and error-prone process for integrating components implemented with different characteristics, e.g., with discrete-time or continuous-time behaviors. Additionally, co-simulation moves the focus from smart energy system design to its interaction with other domains, thus not accurately reproducing the energy system components' behavior. It also lacks a big picture estimation of the power assessment in the smart energy system.

The main limitation of the previously presented approaches is that support for smart energy system modeling is limited, either in the kind of models or in the scale of supported systems. To overcome these limitations, the work in [2] targets more comprehensive support for the smart energy system in a SystemC-based framework, thus avoiding the integration of various tools and allowing the application of the methodology

to a wide range of component models. Previous attempts in the literature have been made to adopt the standard SystemC simulation framework in the smart energy system. [8] uses SystemC for abstracting and modeling physical behaviors. However, the support for the power domain is limited to high-level waveforms or physical equations. It is also limited to the sole DC domain, and the modeling of the environment or physical evolution is restricted to input traces. The work in [9] takes inspiration from [2], but extends the support for cyber-physical electrical energy systems, targeting the Alternating Current (AC) domain and more accurate modeling of those physical aspects that profoundly affect power production and consumption.

Although previous works solve the unified simulation of AC and Direct Current (DC) domains of the smart energy system, there is one critical point that is ignored in the earlier works when conducting a simulation. The battery is usually the energy storage component in the current smart energy system, from small-scale to large-scale applications. Simultaneously, it is not an ideal electric device because the power drawn from the battery is not entirely equal to the power consumed by the load. The delivered power from the battery is strongly dependent on the SOC of the battery and the load current profile [10]. Especially in the smart energy system, the power load consumption is typically non-stationary, e.g., the electric motor's load consumption in the EV and all the household appliances in the home. The simple battery model directly provides the same power quantity as the load requests, but it is not the battery's natural discharge characteristics. To compensate for this defect in the smart energy system's power simulation, we need a battery model sensitive to its SOC and the current load profile. Otherwise, the power simulation results cannot generate the accurate power/energy flow in the smart energy system, which leads to an overly optimistic power assessment because the battery is treated as an ideal electric device. Therefore, in this work, we propose incorporating one circuit equivalent battery model with SOC and load current dependence features in the power simulation to obtain an accurate power assessment in the smart energy system.

III. BATTERY MODELING

The battery is the most popular energy storage device from small-scale to large-scale smart energy systems due to its excellent performance on power delivery capability and high energy storage density. Therefore, the elaborated battery model plays a vital role in the design and optimization of smart energy systems. For instance, battery-powered IoT sensor nodes lifetime estimation and EV driving range prediction are possible only through advanced battery models and accurate simulation techniques. According to the various battery modeling techniques in the literature, there are three main battery models categories: : mathematical models, electrochemical models, and electrical equivalent circuit models. Although the mathematical models and electrochemical models have good accuracy, the complexity of the parameter identification and heavy computation are not convenient for the power assessment in the design time. An electrical equivalent circuit battery model is an excellent choice for power simulation of a smart energy system due to its high accuracy, accessible parameters identification, and light computation. An electrical equivalent circuit battery model is composed of resistors, capacitors, and

voltage or current sources. Fig. 1 shows a widely used circuit equivalent battery model, which is considered as a sort of standard in the electronic design field because of its relatively good trade-off between simplicity and accuracy.

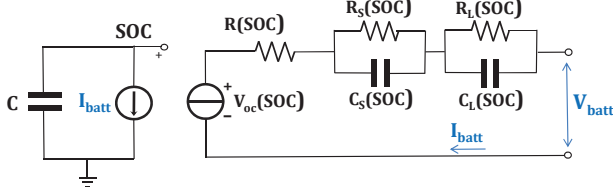

Figure 1. The widely used circuit equivalent battery model [11].

The left part of the model in Fig. 1 includes a capacitor C representing the nominal capacity and a current generator modeling the discharge current I_{batt} . The voltage across the capacitor tracks the SOC (node SOC). In the right part, a voltage-controlled generator expresses the dependence of battery open-circuit voltage V_{oc} on SOC. The Resistor-Capacitor (RC) network models the battery impedance, the series resistance $R(SOC)$ represents the internal resistance, and the two RC pairs track the short-term (R_S, C_S) and long-term (R_L, C_L) time constants of an instant response. Notice that all these parameters are, in the most general scenario, a function of the SOC. The model can track the battery voltage V_{batt} over time for load current profiles with different dynamics (in both time and frequency domains), even if they have the same average current values. In terms of tracking the SOC, the current generator I_{batt} on the left side will give the same result among different load current profiles with the same average current values as indicated in [12], which is not the expected behavior because of the *Rated Capacity effect* exists in a battery. *Rated Capacity effect* is a well-known non-ideal property of a battery. It reveals that the usable capacity depends on the magnitude of the discharge current: a battery is less efficient in converting its chemically stored energy into electrical energy if the current is large.

To integrate the *Rated Capacity effect* in the battery model shown in Fig. 1, the previous work [13] proposed to include this effect by adding a voltage generator $V_{lost}(I_{load})$ in series to the left part of the model (see Fig. 2). With this addition, SOC can be tuned to become more sensitive and accurate to different current magnitudes. However, the model cannot observe the difference between two current square-wave load profiles with the same average and swing values, but different frequencies. The frequency of the load profile is an important aspect; it can affect the SOC of battery like the current magnitude and is always ignored when conducting a power assessment of the energy system. Intuitively, a higher frequency load depletes the battery more since low-efficiency electrochemical reactions occur at a higher frequency. This dependency on load current frequency is underrated in previous works, while this effect is not negligible, as illustrated in [12]. This frequency dependency should be considered in the power analysis since the smart energy system's load profile is always irregular and unpredictable. The different frequency components are hidden in the current load profile, affecting the available battery charge.

For this purpose, another circuit equivalent battery model is proposed, as shown in Fig. 2. The frequency dependence is modeled by integrating the voltage generator $V_{lost}(f_{load})$ on

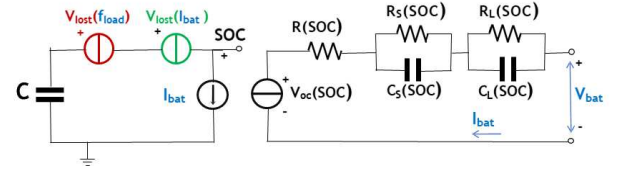

Figure 2. The circuit equivalent model sensitive to current dynamics [12].

the left side of the circuit, which will cause a voltage drop (a loss of SOC) depending on the frequency of the current load profile. In this work, we incorporate the battery model in Fig. 2 for the power assessment of the smart energy system. For a given battery, the methodologies to derive the dependencies of battery capacity on current load magnitude and frequency are used on the left side of the battery model in Fig. 2 and are described in [12]. It also introduces how to use the model in the simulation, particularly for the battery frequency-dependent simulation. The battery model shown in Fig. 2 represents one single battery cell; it can be directly adopted in the small-scale smart energy system with only one battery cell. However, for the battery energy storage system installed in the large-scale smart energy systems, the systems typically have a battery pack composed of massive cells connected in series and parallel to achieve expected power and energy rates. A commonly used approach to build the battery pack model assumes all the cells behave identically within the pack, then ideally scale up the battery cell's electrical parameters according to the serial and parallel connectivity. This method guarantees a faster simulation and higher flexibility in modeling and simulation of a large battery pack. In this way, not all the cells have to be simulated individually; a battery pack behaves at the electrical terminals the same way as a single battery cell, while the electric values have been ideally scaled-up.

IV. SYSTEMC-AMS SIMULATION FRAMEWORK

A. Simulation Framework Architecture

To conduct the smart energy system's power assessment, the designer needs to run a smart energy system simulation to track power production, power distribution, and power consumption. We can classify four main categories in the smart energy system: power source, power load, energy storage, and conversion components. The small-scale systems typically operate in the DC domain, while both DC and AC domains are covered for the large-scale system. Fig. 3 shows a generic architecture template of the smart energy system; it comprises all kinds of components included in the smart energy systems from DC to AC domain.

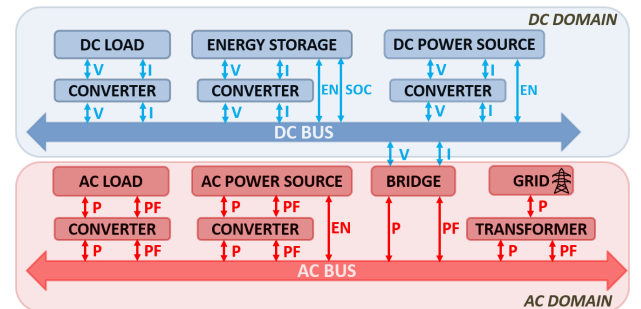

Figure 3. Generic smart energy system modular architectural template.

We adopted the simulation framework proposed in [2] in this work, although it only focuses on small-size smart

electronic systems and targets various non-functional properties. In our work, we concentrate on the power property and extend the support of small-size smart electronic systems to the general smart energy system, as shown in Fig. 3. The adopted simulation framework indicated in Fig. 3 shows a bus-based modular architecture; it mimics the structure of a typical smart energy system. Notice that the small-scale system only works in the DC domain. Four main components are included in this framework, loads (acting as energy consumers), power sources (acting as power generators), converters, and energy storage devices (storing energy from power generators and providing to energy consumers).

The ports of the modules in the DC and AC domains shown in Fig. 3 are different, where the DC ports are modeled as V and I and the AC ports are modeled as P and PF . The reason is that the AC domain's power is not the same as the power in the DC domain. The power can be directly modeled as voltage and current in the DC domain. However, the AC power is composed of two components, namely, active and reactive power. The sum of these two powers is called apparent power. In general, the current and voltage in the AC domain are not the same sinusoidal curves; the two curves may be out of phase by a degree depending on the type of component. The PF is called the power factor, which is the parameter that represents this degree. Therefore, we can use P to describe the active power and the corresponding power factor PF to compute the apparent power.

Components are connected through a power bus in both AC and DC domains, which allows the power to combine and propagate within the system. The power management policy is implemented in the system buses (either AC or DC). Additionally, the policy considers the power balance between generation and consumption, to activate or de-activate components through enabling ports, as indicated by EN in Fig. 3. The connections of different components to the buses need converters, to maintain the same voltage level of the bus, or inverters, to convert between the DC and the AC domains. Connections between different domains are finally managed by bridges that behave the same as an inverter.

B. Implementation Simulation Framework

As described in the previous sections, a smart energy system is typically composed of various components. Heterogeneity is one main feature of the smart energy system. Manipulating different heterogeneous models in one system is not an easy task. We adopted the methodology proposed in [9] to model different components in the smart energy system by using SystemC-AMS language, which is also the reference language to implement the whole simulation framework. It supports multiple abstraction levels for the modeling and simulation in a wide range of domains by using a single language, which satisfies the heterogeneous modeling and simulation of the smart energy system. Models can be built by choosing the most suitable abstraction level, and native converters can be exploited to simulate different abstraction levels simultaneously.

SystemC is an extension of C/C++ language with specific libraries to describe hardware, and it is widely used in digital design for early-stage analyses. Its Analog Mixed Signal (AMS) extension [14] was invented for modeling and simulating the interactions between analog/mixed signal systems..

It provides three different Models of Computation (MoC) to cover various domains. Timed Data-Flow (TDF) models are scheduled statically by considering their producer-consumer dependencies in the discrete-time domain. Each TDF module is characterized by a simulation time step used by the TDF solver to insert timed activation events in the standard SystemC event queue. This event queue ensures efficient computation, as it avoids any runtime dynamic event management. Another two abstraction levels support continuous-time models. Linear Signal Flow (LSF) supports continuous-time modeling through a library of pre-defined non-conservative primitive modules that can be used for modeling the sophisticated mechanical model, e.g., the wind turbine model. Electrical Linear Network (ELN) MoC model the electrical network by connecting the instantiations of pre-defined primitives, which is used for modeling the circuit equivalent model, e.g., our adopted circuit equivalent battery model.

V. SIMULATION RESULTS OF TWO CASE STUDIES

We use two case studies to illustrate the importance of the elaborated battery model for the power assessment in the smart energy system. All simulations conducted in this section are implemented with SystemC-AMS version 2.3 and run on a server with Intel Xeon 2.40 GHz CPU and 128GB RAM, as well as Ubuntu operating system version 18.04.

A. Small-scale smart energy system case study

One multi-sensor IoT device described in [15] is selected as the first small-scale case study. It has (1) four sensors to monitor four different environmental quantities, namely, wind speed and direction, gas, PM2.5 and infrared; (2) one microcontroller that manages the scheduling of the sensors activities by controlling their power state; (3) one transmission unit for sending data to the data center, and (4) one lithium battery that provides the power to the device. This case study only operates in the DC domain, and there is only power consumed and energy storage components in the system. Fig. 4 shows the skeleton of this small-scale smart energy system.

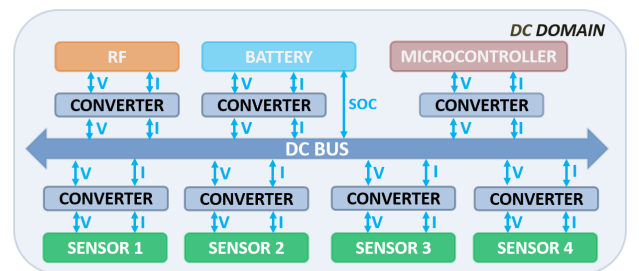

Figure 4. Modular architecture of smart IoT sensor nodes energy system.

All the components in the system are modeled by SystemC-AMS. The sensors, Radio Frequency (RF) transceiver, and microcontroller components are modeled by TDF MoC since they are pure power consumed units. Table I lists the power consumption of these units in both active and idle states. The battery is modeled by ELN MoC, as shown in Fig. 2. We selected the Panasonic 18650B lithium battery in our simulations. It has 3,200 mAh nominal capacity and 3.6V rated voltage. All the converters in the system are modeled by the same methodology proposed in [4].

This smart system's operating scenario is composed of a periodic sequence of the following tasks: sensing, computation,

TABLE I. POWER CONSUMPTION OF EACH COMPONENT IN THE SYSTEM.

Component	State	Voltage (V)	Current (mA)
Infrared Sensor	Idle	2.5	0.0001
	Active	5.0	10.0
Wind Sensor	Idle	5.0	0.001
	Active	12.0	50.0
Gas Sensor	Idle	2.0	0.0015
	Active	5.0	168.9
PM2.5 Sensor	Idle	2.0	2.0
	Active	5.0	220.0
RF	Idle	0	0
	Active	1.8	18.8
Microcontroller	Idle	3.0	0.002
	Active	3.0	6.0

and transmission. When the system executes these tasks, it is in the active period (T_{active}), then the system enters a longer idle period (T_{idle}) after these operations. The executive order of different components within the T_{active} interval becomes a critical point for improving the system's energy efficiency. Notably, different scheduling of sensors generate different load current profiles, finally affecting the available SOC of battery, which determines the lifetime of the system.

To show the influence of the battery model accuracy, we tested two scheduling policies of these four sensors. One is all the sensors work concurrently; the other is the sensors operate individually one by one. Both schedules are simulating with the simple battery model shown in Fig. 1 and the elaborated battery model indicated in Fig. 2. We set the sensing tasks to spend 10s individually, the computational task and transmitting task both execute for 5s, and the total length the working period is 120s. We run the simulations in a one-day length to compare the difference between two battery models and two schedules.

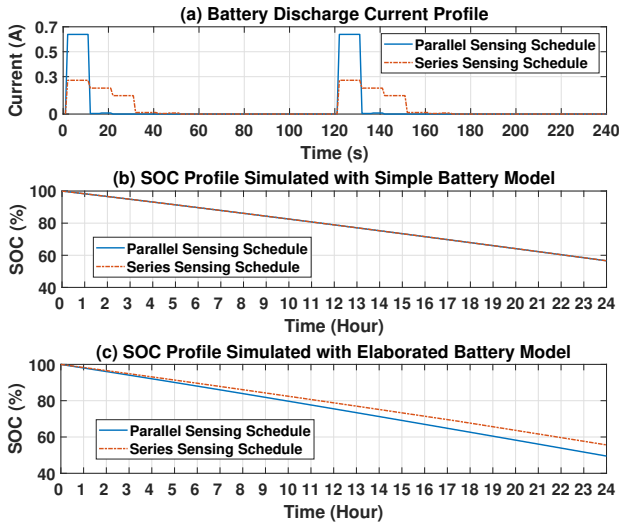

Figure 5. Results from two battery models with different schedules.

Fig. 5-a shows the battery discharge current profile within two periods for both schedules; it indicates that the parallel schedule has higher peak currents; thus, it should generate more significant *Rated Capacity effect* on the battery. However, the battery model shown in Fig. 1 cannot show this effect as illustrated in Fig. 5-b, the SOC profiles within one day of these two schedules are the same. We can see the difference between these two schedules clearly by using the more elaborate battery model in the simulations, as shown in Fig. 5-c. This reveals that the parallel schedule consumes 6.14% more than the

series sensing schedule. Designing the optimal energy-efficient schedule is not the target of this work; our aim is to illustrate that a more comprehensive battery model allows exploring the optimal schedule during the design time accurately.

B. Large-scale smart energy system case study

The second case study is a large-scale smart energy system composed of is an EV, a Photovoltaic (PV) array, a house, and the utility grid. The architecture of this case study is shown in Fig. 6 and it covers both the DC and AC domains. The PV array is modeled by starting from a single PV module model [16], then ideally scaling up to the size of the PV array with 15 300W rated power PV modules. The single battery cell model is the same as in our previous case study. It scaled up to a 30kWh EV battery pack model according to a 50s50p configuration. The EV motor model is derived by the method provided in [4]. The power consumption of the house is extracted from the dataset [17]. The input traces of solar irradiance used in the simulation are extracted from the dataset provided by the National Renewable Energy Laboratory (NREL) Measurement and Instrumentation Data Center (MIDC) [18]. For the driving profile, we assumed the EV operates a daily commute routine. The grid is modeled by a module that can absorb the system's surplus power and provide the system's power deficit.

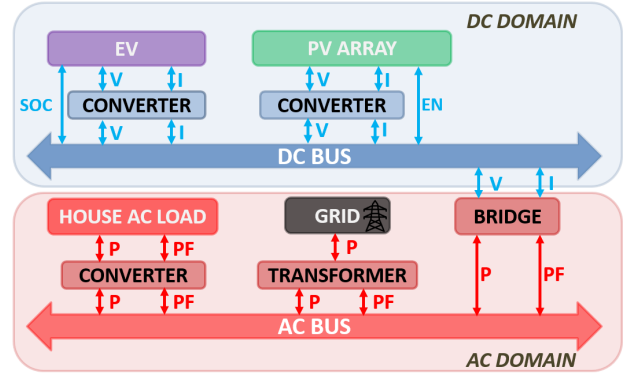

Figure 6. Modular architecture of smart house energy system.

The EV operates the daily commute routine between the house and the working place. The operational scenarios of this case study have two phases: 1) when the EV is not plugged in at the house, the PV array provides the solar power to support power consumption of the house; if any additional power, it will be sold to the grid; any power deficit will be bought from the grid; 2) when the EV is connected to the house, the power consumption of the house is provided by the EV first, then the house starts to buy power from the utility grid if the battery pack is depleted; finally, the EV and the house start to buy the power from the grid during the lowest electricity price period. A time-dependent electricity price is adopted in the simulation, as indicated in Table II. These are the basic operations of this case study. Smart management policies can be explored in this case study in order to improve the efficiency of energy or for cost saving. While this is beyond the target of this work, we aim to show the accuracy improvement of the power assessment after incorporating an elaborated battery model.

Fig. 7 shows the EV battery pack SOC evolution for the weekdays in one week. Fig. 7-a and Fig. 7-b show the

TABLE II. ELECTRICITY PRICES FOR DIFFERENT TIMES OF THE DAY.

Price Category	Value (\$/kWh)	Time span
Buying F1	0.220	10am-3pm 6pm-9pm
Buying F2	0.215	7am-10am 3pm-6pm 9pm-11pm
Buying F3	0.200	11pm-7am
Selling	0.030	all day

power consumption and generation in the system. Fig. 7-c compares the SOC profiles derived from two different battery models. This reveals that the battery pack has full charge at the beginning; then, it starts to discharge power after the EV leaves the house to the working place; the SOC remains stable when the EV is parked at the working place; then, the SOC decreases again when the EV returns the house; the EV provides the power to the house if needed; finally, the battery pack is charged after 11 pm since the electricity price decreases to the lowest price. We assume the constant speed of the EV during the driving period, and we focus on the period when the EV interacts with the system.

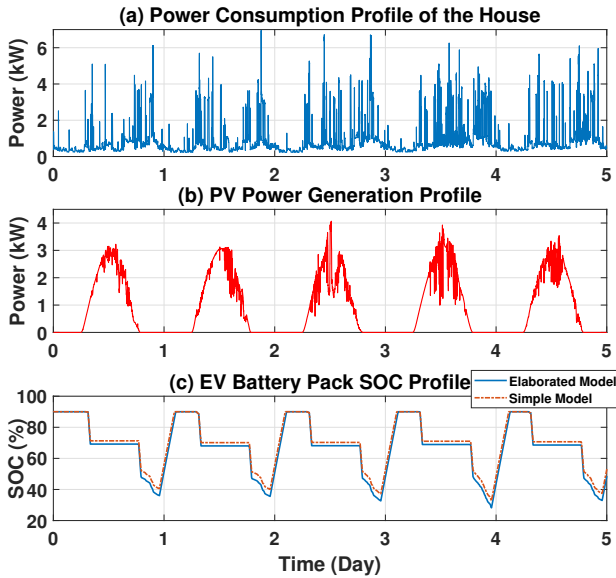

Figure 7. Simulation results from two different battery models.

This case study verifies the importance of the battery model accuracy in the power simulation of a smart energy system again. Fig. 7-c illustrates that the simple battery model makes an underestimated power assessment during the simulation; the SOC profile derived by the elaborated battery model is below the simple battery model one, which means the battery pack needs to be charged more after 11 pm. The simple battery model leads to an optimistic inaccurate power estimation of the smart energy system. For a long term comparison, the total bought energy from the grid after one year is 4,163 kWh for simulating with the elaborated model and 3,882 kWh with the simple model, which has a 7.2% difference.

VI. CONCLUSION

An accurate power assessment in the smart energy system simulation requires sophisticated models of different components in the system, and the battery model is the critical one due to its non-ideal properties. This paper proposed incorporating one elaborated circuit equivalent battery model that accounts for SOC and current load dynamics in the power

simulation of the smart energy system. The elaborated model can conduct a more accurate power assessment of the smart energy system than using the traditional circuit equivalent battery model. We demonstrate the importance of the battery model accuracy for the power estimation of the smart energy system by using two different scales of case studies.

REFERENCES

- [1] S. Yue, D. Zhu, Y. Wang, M. Pedram, Y. Kim, and N. Chang, "SIMES: A simulator for hybrid electrical energy storage systems," in International Symposium on Low Power Electronics and Design (ISLPED). IEEE, 2013, pp. 33–38.
- [2] S. Vinco, Y. Chen, F. Fummi, E. Macii, and M. Poncino, "A layered methodology for the simulation of extra-functional properties in smart systems," IEEE Transactions on Computer-Aided Design of Integrated Circuits and Systems, vol. 36, no. 10, 2017, pp. 1702–1715.
- [3] M. A. Mohamed and A. M. Eltamaly, Modeling and simulation of smart grid integrated with hybrid renewable energy systems. Springer, 2018.
- [4] Y. Chen et al., "A systemc-ams framework for the design and simulation of energy management in electric vehicles," IEEE Access, vol. 7, 2019, pp. 25 779–25 791.
- [5] B. Palmintier et al., "A power hardware-in-the-loop platform with remote distribution circuit cosimulation," IEEE Transactions on Industrial Electronics, vol. 62, no. 4, 2014, pp. 2236–2245.
- [6] P. Palensky, E. Widl, and A. Elsheikh, "Simulating cyber-physical energy systems: Challenges, tools and methods," IEEE Transactions on Systems, Man, and Cybernetics: Systems, vol. 44, no. 3, 2013.
- [7] P. Palensky, A. van der Meer, C. Lopez, A. Joseph, and K. Pan, "Applied cosimulation of intelligent power systems: Implementing hybrid simulators for complex power systems," IEEE Industrial Electronics Magazine, vol. 11, no. 2, 2017, pp. 6–21.
- [8] J. M. Molina, X. Pan, C. Grimm, and M. Damm, "A framework for model-based design of embedded systems for energy management," in 2013 Workshop on Modeling and Simulation of Cyber-Physical Energy Systems (MSCPES). IEEE, 2013, pp. 1–6.
- [9] Y. Chen, S. Vinco, D. J. Pagliari, P. Montuschi, E. Macii, and M. Poncino, "Modeling and simulation of cyber-physical electrical energy systems with SystemC-AMS," IEEE Transactions on Sustainable Computing, 2020.
- [10] D. Baek et al., "Battery-aware operation range estimation for terrestrial and aerial electric vehicles," IEEE Transactions on Vehicular Technology, vol. 68, no. 6, 2019, pp. 5471–5482.
- [11] M. Chen and G. Rincón-Mora, "Accurate electrical battery model capable of predicting runtime and IV performance," IEEE Transactions on Energy Conversion, vol. 21, no. 2, 2006, pp. 504–511.
- [12] Y. Chen, E. Macii, and M. Poncino, "A circuit-equivalent battery model accounting for the dependency on load frequency," in Design, Automation & Test in Europe Conference & Exhibition (DATE), 2017. European Design and Automation Association, 2017, pp. 1177–1182.
- [13] L. Benini, G. Castelli, A. Macii, E. Macii, M. Poncino, and R. Scarsi, "Discrete-time battery models for system-level low-power design," IEEE Transactions on VLSI Systems, vol. 9, no. 5, 2001, pp. 630–640.
- [14] IEEE, "Standard for Standard SystemC Analog/Mixed-Signal Extensions Language Reference Manual," Std 1666.1-2016, 2016, pp. 1–236.
- [15] Y. Chen, D. Jahier Pagliari, E. Macii, and M. Poncino, "Battery-aware design exploration of scheduling policies for multi-sensor devices," in Proceedings of the 2018 on Great Lakes Symposium on VLSI, 2018, pp. 201–206.
- [16] S. Vinco, Y. Chen, E. Macii, and M. Poncino, "A unified model of power sources for the simulation of electrical energy systems," in Proceedings of the 26th edition on Great Lakes Symposium on VLSI, 2016, pp. 281–286.
- [17] J. Kelly and W. Knottenbelt, "The uk-dale dataset, domestic appliance-level electricity demand and whole-house demand from five uk homes," Scientific data, vol. 2, no. 1, 2015, pp. 1–14.
- [18] National Renewable Energy Laboratory (NREL), "Measurement and Instrumentation Data Center," URL: <https://midcdmz.nrel.gov/> [accessed: 2020-07-27].