

Grasping Mechanism Concepts Oriented to Debris for Removal Applications

*Original*

Grasping Mechanism Concepts Oriented to Debris for Removal Applications / Scarcia, Michael; Palmieri, Pierpaolo; Pastorelli, Stefano; Mauro, Stefano. - ELETTRONICO. - (2019). ((Intervento presentato al convegno 70th International Astronautical Congress, IAC 2019 tenutosi a Washington D.C. (USA) nel 21-25 October 2019.

*Availability:*

This version is available at: 11583/2847453 since: 2020-10-02T18:39:07Z

*Publisher:*

International Astronautical Federation, IAF

*Published*

DOI:

*Terms of use:*

openAccess

This article is made available under terms and conditions as specified in the corresponding bibliographic description in the repository

*Publisher copyright*

(Article begins on next page)

## Grasping Mechanism Concepts Oriented to Debris for Removal Applications

Michael Scarcia, Pierpaolo Palmieri\*, Stefano Paolo Pastorelli, Stefano Mauro

*Politecnico di Torino, Department of Mechanical and Aerospace*

[michael.scarcia@polito.it](mailto:michael.scarcia@polito.it), [pierpaolo.palmieri@polito.it](mailto:pierpaolo.palmieri@polito.it), [stefano.pastorelli@polito.it](mailto:stefano.pastorelli@polito.it), [stefano.mauro@polito.it](mailto:stefano.mauro@polito.it)

\* Corresponding Author

### Abstract

Space debris regulation and reduction is an increasingly relevant theme. Several initiatives in the aerospace field on debris removal are pursued by space agencies. In this context, an analysis has been conducted on diverse mechanisms for spacecraft coupling in Low Earth Orbit (LEO) with a robotic arm. Four grasping mechanical concepts for space debris removal applications have been proposed in respect of restrictive requirements. Two concepts are based on probe and drogue mating systems and the other two on finger-like grasping systems. The paper describes the preliminary design and the operation of the proposed mechanisms. In addition, it lays the foundation for a trade-off procedure in order to evaluate advantages and drawbacks for each concept.

**Keywords:** berthing, grasping, clean space, debris removal

### 1. Introduction

In almost 50 years of space activities more than 4800 launches placed about 5000 satellites into orbit, of which only a minor fraction of about 1000 are still operational today [1]. Due to the about 200 on-orbit breakups which have been recorded since 1957 [2], nowadays 75000 objects larger than 1 cm are orbiting Earth and about 18000 of these are large enough to be regularly monitored in order to avoid collision with operational satellites. For this reason, since 2012, ESA's Clean Space initiative is pioneering an eco-friendly approach to space activities [1].

Since the beginning of space exploration, mating operations have played a crucial role and today, due to the Active Debris Removal (ADR) activities, these procedures are increasingly relevant.

The ability to mechanically connect a chaser satellite with a target satellite allowed to perform several important missions and continues to be essential for space activities. Examples of these missions are the on-orbit assembly of the ISS, the missions for the Hubble telescope, and the crew and cargo delivery to the ISS by spacecraft such as Soyuz, Progress, ATV, and Dragon.

The first docking in history was achieved by NASA using a probe and drogue mechanism. It was performed on March 16, 1966, between The Gemini VIII and the Agena. On the other hand, the first Russian docking took place on January 4, 1969, also with a probe and drogue mechanism [3]. Updated versions of the first Russian probe and drogue are still installed in the Soyuz, Progress, and ATV spacecraft.

The first peripheral system tested was the Apollo/Soyuz mechanism, APAS 75. Using this mechanism each spacecraft could assume either an active or a passive role; for this reason, this kind of system is called androgynous. ESA is currently developing a

peripheral system called IBDM with QinetiQ Space as prime contractor. This mechanism features electromagnetic latches to secure the first stage of docking operation [4].

While IBDM is still in development phase, the last successfully tested in space docking mechanism was the Orbital Express Capture System (OECS) used in the Orbital Express (OE) mission [5]. This mission took place in 2007. The capture system consists of a passive and an active side. The active side is equipped with three grappling fingers with a common actuator. The passive side consists of three wedges between which the fingers may be received and laser sensors that verify the finger presence.

To attend berthing operations several solutions have been proposed and the use of robotic manipulators for space servicing conducted to several advantages.

A most well-known example of space robotic manipulator is Canadarm. It was first tested in orbit in 1981, on Space Shuttle Columbia's STS-2 mission using a grapple fixture on the target satellite. One of its most crucial tasks is to perform cosmic catches capturing and docking unpiloted cargo ships. Although Canadarm and Canadarm2 are the most popular space servicing robotic arms, several other attempts were made in last decades.

The capturing of an uncooperative tumbling target satellite was conducted with a robotic arm during the "Deutsche Orbital Servicing Mission" (DEOS) [6]. The manipulator, equipped with a gripper and a stereo camera system, grasped the passive interface on the target spacecraft and eliminate relative motion between both satellite bodies. Canadarm and Automation and Robotics (A&R) of DEOS can perform a soft link between the chaser and the target spacecraft while the hard capture is performed coupling a passive docking part at the outside

of the Client satellite and an active docking part inside the Servicer satellite.

Other important robotic manipulators realized for space missions are the Japanese Experiment Module Remote Manipulator System (JEMRMS) and the European Robotic Arm (ERA). ERA is the last robotic manipulator to be designed by Airbus Defence and Space for ESA. It is intended to be attached to the Russian segment of the ISS in order to compensate the inability of Canadarm2 robots in handling external payloads with the Russian grapple fixture.

Another crucial step in robotic space manipulation was made in e.Deorbit Mission. It is a compelling mission concept that aims to address the EOL disposal of ESA's satellite Envisat [7]. This satellite has the highest catastrophic risk-impact of any European spacecraft. In this delicate operation strong safety constraints for the avoidance of debris generation have been applied. The chaser spacecraft has been conceived as an automated vehicle with autonomous fail-safe monitoring and reaction behaviour functions.

Among these robotic mating systems, it is also worth mentioning ASSIST, developed by GMV in collaboration with ESA and Thales Alenia Space. This project has been thought to allow grasping and refuelling on-orbit for GEO spacecraft [8].

The deep difference between these approaches and ADR is the uncollaborative nature of debris. For this reason, rather than mating procedure, it is better talking about capture techniques. Many methods for space debris capturing have been proposed and according to their characteristics the methods are divided into two main categories: contact and contactless capturing methods. On one hand, contact capturing methods include stiff connection capturing (tentacles capturing and robotic arm) and flexible connection capturing (net capturing, tether-gripper mechanism, harpoon mechanism). On the other hand, contactless capturing methods embrace electrostatic tractor and gravity tractor [9]. The advantage in using a flexible capturing method is to allow a large capturing distance and to be compatible for different debris. This aspect is even more accentuated for contactless technologies. In contrast, the use of a robotic arm leads to a higher stiffness in the connection and a more reliable control and readiness level.

Nevertheless, capturing a non-collaborative spacecraft using a robotic arm has never been done before. In order to stabilize the environment, 10 objects should be removed from LEO per year because the population of massive objects has reached a critical density [1]. This necessity leads to a growing research on the field of space robotic manipulation and capture of non-collaborative space debris using a Space Servicing Vehicle (SSV).

## 2. Capture procedure and system requirements

A repeatable capture operation of an uncooperative target satellite by a SSV from LEO is a purpose to be achieved. To reach this objective, the grasping system must include a passive interface on the target satellite, which does not require any activation; a navigation support on the target satellite to facilitate capture and a mechanical interface on the SSV. Besides the rigid connection, the mechanism has to minimize the impact on the target satellite and reduce the risk, cost and complexity of the chaser.

Once the spacecraft are fastened, the grasping system should maintain its state to accomplish a full capture. Furthermore, the system shall be capable of performing 10 cycles of capture/release, including approaching, soft capture, full capture and final release for uncontrolled re-entry.

### 2.1 Identification of requirements and specifications

The European Space Agency is embracing the trend of a more responsible approach to space activities investing in new technologies for removal of debris and in the design of non-debris creating missions. With its Clean Space Initiative, in 2012, ESA summarized the main characters in the Aerospace field on Debris for Removal activities. In this branch of research ESA proposed the development of a Passive Mechanical and Rendezvous Interface for Capture after End-of-Life (PRINCE) [10] and the technical requirements it shall respect. Its restrictive requirements have been considered for the development of the concepts of this work. The system shall accommodate a relative misalignment between the target and chaser and a relative rate. These data are summarised in Table 1. Other limitations to the system design are dimensions and weight of the passive interface. The passive interface of the integrated grasping fixture shall have a maximum bounding box volume of 0.15 x 0.15 x 0.15 m<sup>3</sup> and an approach frustum of 0.15 x 0.15 m<sup>2</sup> in small base, 0.5 m height and 0.25 x 0.25 m<sup>2</sup> in large base and a mass of maximum 1.5 kg.

Table 1. Technical specifications

	Misalignment
x - longitudinal	20 mm
y - lateral	20 mm
z - lateral	20 mm
roll	3 deg
pitch	3 deg
yaw	3 deg
x - relative rate	1 deg/s
y - relative rate	1 deg/s
z - relative rate	1 deg/s

Under these constraints some preliminary concepts have been developed. Before describing them, it is worth

mentioning the operational phases of the approaching and capture procedure.

### 2.2 Example of capture and removal operation

The capture and removal operation of a non-cooperative orbiting object starts when the chaser spacecraft is flying close to the target object and the main parameters of the non-cooperative object to be captured are identified. Within them it is crucial the precise position of the centre of mass, mass distribution (i.e. main inertia axis and a-dimensional inertia tensor) and angular velocity including its modulus, direction and sign. Other relevant information is the mass, the presence of unconstrained parts and the position of interfaces for berthing or, in the case, docking. This information should be retrieved combining tracking data, made disposable by ground observation, archive data, and direct on-site observation of the motion of markers or of features. The transfer to near target orbit and identification phase is preliminary to the capture. Some examples of algorithms to evaluate these data are provided in [11,12].

The capture procedure, schematically illustrated in Fig. 1, starts when the chaser begins an approach manoeuvre. The manoeuvre can be divided up in two phases: a flying around manoeuvre, which ends when the approach axis is intercepted (operation 1), and a straight-line manoeuvre along the tumbling axis (operation 2). This last manoeuvre lasts within 300 and 600 seconds.

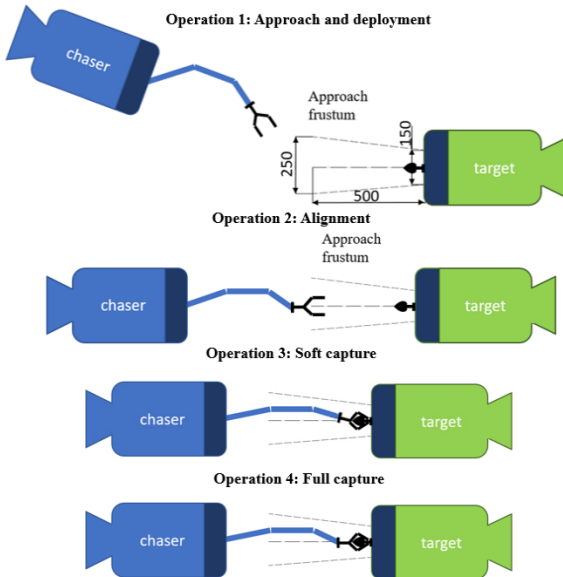

Fig. 1. Sequence of operations for capture procedure

At the end of the approach manoeuvre the relative motion must be small enough to allow the robot to follow a path to bring its end effector in contact with the passive interface on the target. In the first capture phase the chaser enters in the target approach frustum compensating the roll angle and misalignments. The

gripper of the robot performs a capture before contact operation delimitating the passive interface in a constrained volume preventing escaping possibility. Then, the gripper closes, and a soft capture is completed (operation 3).

In the last phase the full capture is completed using a locking device to eliminate roll angle misalignment and performing a hard closure (operation 4).

The capture and deorbit mission ends when the chaser reaches its designed orbit and starts waiting for a new mission [13].

### 3. Mechanical concepts

The concepts are developed according to a scenario in which they are part of a berthing system with a robotic arm which controls the active interface on a SSV guiding it towards the passive interface of the grasping mechanism on the space debris. The initial concept for four mating systems has been conceived. They can be divided into two different groups:

- two concepts based on the probe and drogue mating system (probe and drogue mechanism and central active system);
- two concepts based on the realization of a finger like grasping system (fingers like mechanism and chuck mechanism).

All these solutions are based on the goal of performing a stiff connection between the SSV and the passive interface of the target satellite with a robotic arm. Particular attention has been paid to the feasible end effector of the robotic grasping system.

#### 3.1 Probe and drogue mechanism

This concept is based on the probe and drogue layout. The male part of the mechanism consists of a probe supported by a universal joint. On the other hand, the female part is a conical frustum that guides the probe towards a socket located at its vertex, where the soft docking is achieved by three spring-loaded latches hinged to the probe. In the end, hard docking is accomplished locking the female part to the base of the active part using 3 closed hooks activated by a cam system to let them move on a linear guide. This concept was developed as a possible evolution of the docking mechanism designed for the STRONG mission described in [14].

The proposed concept is shown in Fig. 2. A probe (1) placed on a universal joint (2) is used as male part of the active system. The use of a robotic arm allows for compensating the alignment errors with extreme precision. The passive interface is like STRONG, but it has been designed to respect the size specifications of the present application. The principle of a probe capturing is to expand three petals (3) on the top of the probe on a suitable surface of the passive interface (4) after inserting the probe into the approach frustum. With this solution a

soft capture can be performed, then, the hard capture that eliminate the roll angle degree of freedom can be achieved by mean of three hooks (5) which are arranged on the robot flange (6).

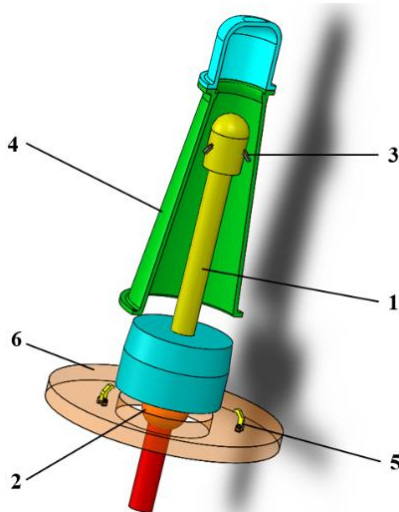

Fig. 2. Mechanical concept inspired by STRONG mechanism. Probe (1), universal joint (2), petals (3), passive interface (4), hooks (5), flange (6).

### 3.2 Central Active System (CAS)

A second concept for capturing uncooperative spacecrafts was developed as an evolution of the docking mechanism described in [15]. This Central Active Mechanism concept satisfies some of the functional requirement taken as reference and an adapted version could be considered as a possible layout for the grasping system for space debris removal.

A functional model of the system is shown in Fig. 3. It is made up of an active part and a passive one.

The active part has a linear actuator (1) for controlling the longitudinal approach between the chaser and the target. The actuator is installed on a universal joint (2), driven by two actuators (3) useful to eliminate the lateral errors between the spacecraft. The passive part is a socket with conical guide built on a spherical joint (4). After the deployment phase, when the linear actuator is extended nearly to its maximum stroke, during the alignment phase, the control system, which is based on the two rotational actuators, drives the longitudinal actuator to point towards the centre of the conical socket, through a position feedback system based on a stereo-vision rig (5). The action of the linear actuator lets its tip get in contact with the female socket on the passive side. Some spring-loaded elements (6) mechanically connect the two interfaces, once the tip is pushed inside the socket, achieving the soft docking. This connection allows relative rotational motion anyhow between the spacecraft. In the end, the three servo-actuators eliminate relative position errors and reduce the distance between target

and chaser. Before the hard docking is achieved using a set of hooks (7), dampers (8) combined with conical housing coupling devices (9) eliminate any angular error between the spacecraft.

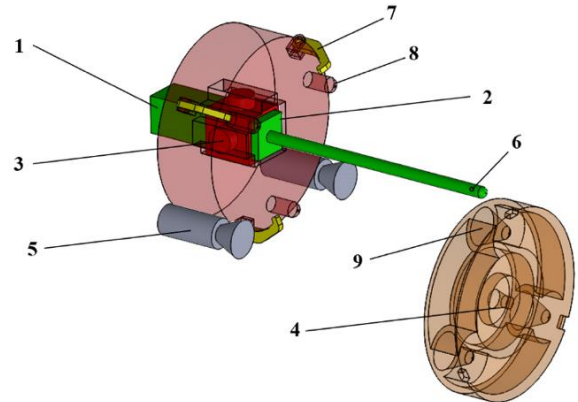

Fig. 3. Central Active Mechanism functional mechanism. Linear actuator (1), universal joint (2), additional actuators (3), spherical joint (4), stereo-vision rig (5), spring-loaded elements (6), hooks (7), dampers (8), conical housing coupling devices (9).

### 3.3 Fingers-like mechanism

On the base of the OECS [5], used during the DARPA's Orbital Express mission, another concept can be developed. The active side of the capture system is equipped with three fingers-like grapple hooks, while the passive side consists of three wedges where the fingers may be received. This half of the mechanism is equipped with laser sensors to verify the presence of the fingers [16]. During the mating sequence the fingers are deployed while the passive side performs a station keeping manoeuvre. Subsequently, the motor is activated and the fingers are closed toward the target by means of a ball screw. The bodies are aligned by the interaction of the fingers with the passive guides. After that, the linkage tips bring the bodies together as they engage a shelf feature on the passive side. Push-off rods dampen the impact between the mechanism halves. These rods are equipped with a spring and a Coulomb damper. Finally, the passive side is fully constrained by a set of cavities combined with cones. The stiffness of the connection is increased by applying a preload with the motor. Once the desired preload is reached, a brake maintains it.

In the proposed concept, shown in Fig. 4, the active part of the mechanism is composed of three fingers (1), which have conjugated profiles with the passive interface, that is shaped as a pinecone (2). Fingers have torsion springs in correspondence to the cylindrical joints to maintain an appropriate rest position. A single linear actuator (3) can deploy the fingers, during the approaching phase, with respect to the fixed external frame (4). To perform hard capture the fingers are



completely closed and roll rotation is arrested by suitable blocking system.

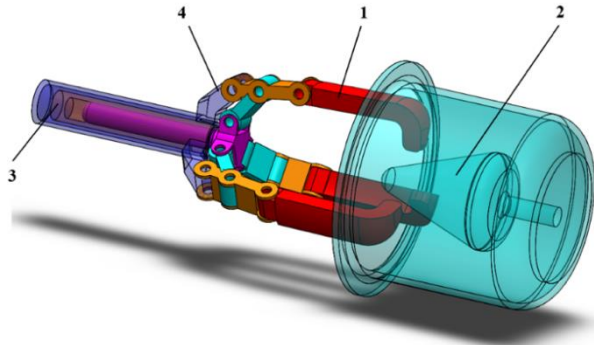

Fig. 4. Concept of fingers-like mechanism. Fingers (1), passive interface (2), linear actuator (3), fixed external frame (4).

### 3.3 Chuck mechanism

This concept, illustrated in Fig. 5, is based on the idea of a grasping system with fingers, but it is more like a jawed chuck commonly used in drills and mills to hold a workpiece in position.

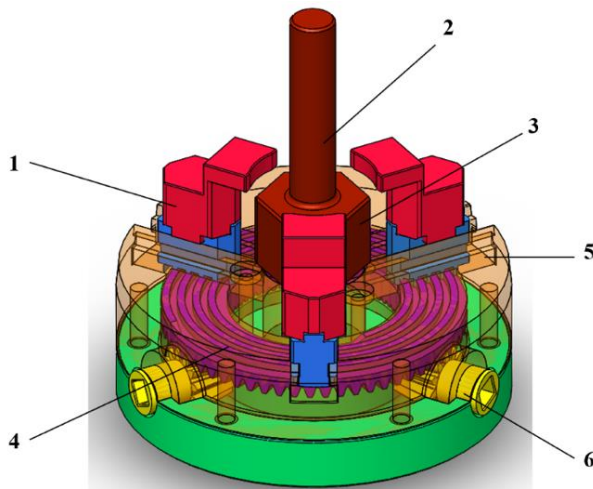

Fig. 5. Mechanical concept based on jawed chuck. Jaws (1), passive interface (2), mating helve (3), scroll plate (4), linear guide (5), bevel gears (6).

A solution with 3 jaws (1) can be used to match with the hexagonal cross section of the passive interface (2). During the approach phase the jaws are deployed. Then, when the mating helve (3) are close to the jaws, they get closer to the passive interface using a scroll plate (4) and a linear guide (5). This let perform a capture before contact. In the last phase the jaws touch the passive interface and, compensating the angular and linear misalignments, they perform the hard capture. The actuation can be applied using two bevel gears (6).

## 4. Preliminary validation and trade off criteria

### 4.1 Identification of mechanical requirements and specifications

To complete the identification of the mechanical requirements for all the components of the system, several possible targets can be considered. They are listed in Table 2 [15].

Table 2. Possible targets in the application

Reference Target	Mass [kg]
LEO-like satellite	2000
Constellation-like satellite	1300
AVUM	700

Two options are considered for the chaser:

- full exploitation of VEGA payload, i.e. 1500 kg mass including fuel;
- 40% exploitation of ARIANE 6 payload, i.e. 4000 kg mass including fuel.

Regarding the application of deorbit thrust, in a first tentative iteration, the need of transmitting a force of 500 N is considered. Supposing this hypothesis, preliminary 1D numerical models can be used to identify the main requirements for stiffness and dumping in the berthing mechanism, exchanged forces and dynamic behaviour of the two spacecrafts during contact. In Fig. 6 the 1D dynamic model used for a first analysis is schematized.

This model is also known as Kelvin model and is one of the simplest and most common models used to study vehicle-to-vehicle collision. An impact between two masses can be schematically represented as two Kelvin elements which can be reduced to one using equivalent stiffness and dumping factors [17], as represented in Fig. 6 (b).

This 1D collision study may be performed to analyse several aspects of the capture such as:

- design loads for the capture mechanism;
- deviation from nominal position after capture;
- stiffness, damping and the effect of the masses.

This model allows, for instance, to achieve the evolution of the positions and velocities of the two bodies after the contact. Furthermore, the exchanged forces between the bodies are fundamental information for the structural design of the mechanism as well as for the control of the SSV.

In order to design the mechanical structure, a parametric analysis is needed. It permits to evaluate the effect of masses, velocities, stiffness and damping during the capture operations on the kinematic and dynamic of the colliding bodies. Furthermore, the same model can be used to execute a preliminary infinite impulse response of the system consequentially to the first impact. To analyse the worst-case scenario, it will be considered the maximum mass for a typical LEO-like satellite to estimate maximum mechanical stress and the minimum

mass to estimate the maximum tendency to escape of the target non-collaborative satellite.

In a second phase, after the trade-off analysis and the layout selection, more detailed 2D and 3D multibody models can be developed to evaluate the remaining mechanical requirements, with a special attention to the torques to be sustained during the contact manoeuvre.

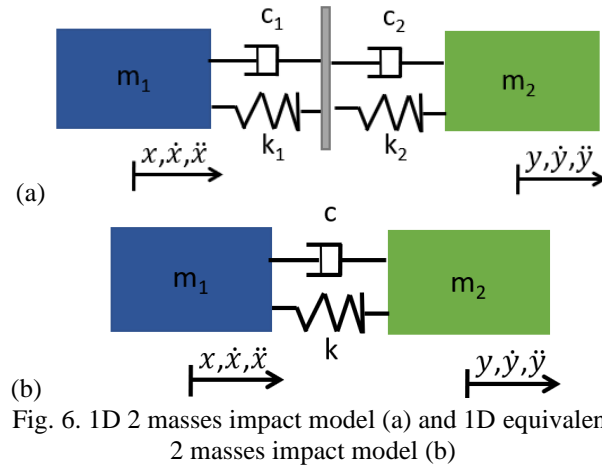

Fig. 6. 1D 2 masses impact model (a) and 1D equivalent 2 masses impact model (b)

#### 4.2 Trade-off criteria

Several parameters are going to be considered to choose the most appropriate mechanism for the mission. Within the large number of parameters that could be considered, the following ones are selected: mass, mechatronic complexity, control complexity, versatility, energy consumption, reliability, functional confidence and schedule risk.

The following lines explain the meaning of the parameters above introduced:

- the mass parameter evaluates the total mass of the mechanism, passive and active parts;
- the mechatronic complexity considers the mechanical complexity, the types and number of sensor and actuators;
- the control complexity evaluates the control logics of the system needed to perform the docking manoeuvres illustrated in section IV;
- the versatility indicates the ability to work with different targets;
- the energy consumption indicates the energy necessary to drive the sensors and the actuators of the mechanism;
- the number of subsystems that create the whole mechanism which is linked to the reliability of the system;
- the reduction in mission risk assesses the risk of collision, debris generation and unsuccessful detumbling of the target;
- the TRL parameter characterizes the maturity of the proposed technology.

Based on the success of the technology on which the concepts are based it is possible to assign them a score regarding functional confidence and select the most suitable mechanical concept for this application [18].

#### 5. Considerations about the developed concepts

In order to accomplish the trade-off procedure, the preliminary drafts for each mechanism herein proposed were developed. Each draft design includes a kinematic method, a preliminary part list and a set of considerations about the control strategy. Some considerations can be made about the volume, mass and number of actuators needed for the proposed mechanical concepts.

Table 3. Masses and dimensions for each concept

Concept	Mass [kg]	Volume [cm <sup>3</sup> ]	Passive interface mass [kg]
Probe and drogue	35	4500	10
CAS	10	1300	2
Fingers	12	1600	1.5
Chuck	7.5	1000	1

##### 5.1 Probe and drogue mechanism

This mechanism includes two motors. The first one is needed to actuate the soft docking system by mean of three radial petals, while the second actuator is used to perform the hard docking and close the radial hooks.

##### 5.2 CAS

As previously outlined, the CAS mechanism performs the mating operation using three servo-actuators and an additional motor to activate the hard docking system. The mass and volume of this concept, of both the active and passive part, are borderline values respect with the specifications. Nevertheless, a resizing of the mechanism is possible to be evaluated.

##### 5.3 Fingers-like mechanism

Regarding the fingers grasping system, a central linear actuator has been thought to activate the mechanism. On the other hand, the hard capture system can be actuated by a second servo-actuator. The hard docking procedure can be reached by mean of an external collar that encircles the fingers and is actuated with a longitudinal movement. A schematic example of this mechanism is depicted in Fig. 7.

A parametric analysis using 3D design has been conducted to verify the compliance of the proposed gripper to the angular and linear misalignments illustrated in Table 1.

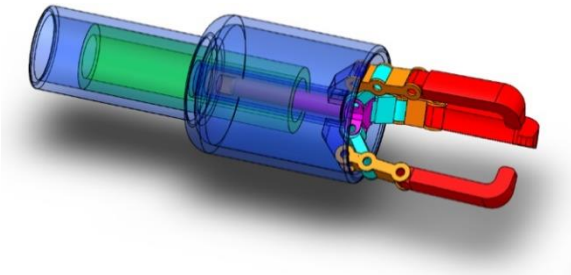

Fig. 7. Schematic representation of hard capture external collar

#### 5.4 Chuck mechanism

This last mechanism is probably the simplest regarding the actuation point of view. It uses only an actuator to activate the scroll plate making possible the radial movement of the three jaws and performing the hard closure with respect to the passive interface.

Fig. 8 demonstrates that the mechanical concept can overcome the maximum linear and angular misalignments. Further analysis should be carried out to tune the system in order to allow maximum expected misalignment.

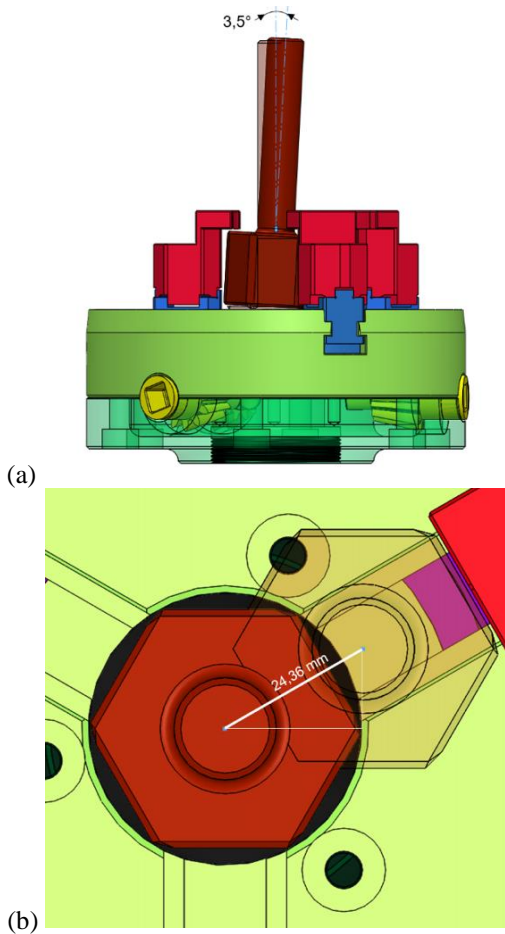

Fig. 8. Maximum angular (a) and linear (b) misalignments of the chuck mechanism

## 6. Conclusions

Restrictive requirements have been considered for the development of four grasping mechanical concepts for space debris removal applications.

The concepts that were proposed consider completely different layout and grasping sequence. Two of them are based on the well-known probe and drogue idea, and in one of this solution the frustum is completely virtual, with a strong reduction in the incumbrance. The other ones consider fingered mechanisms, and the main difference is in the way to perform the full capture.

The selection of the best design must be carried out considering both the properties of the grasping system and the expected performance of the handling robot, of the GNC system and of the local navigation algorithm for the end effector of the robot.

An analysis was carried out to compare the different proposed concepts of grasping mechanisms considering only the point of view of their mechanical properties. In order to carry out a selection, several trade-off criteria were defined. These criteria consider a large number of parameters to include all the mean aspects related with the total reliability of the system within the mission as well as during the design and development phases.

The systems are also compared with reference to their performance, within which adaptability to large changes in the masses of the spacecraft involved in the docking manoeuvre is considered most relevant.

The developed draft design instruments allow a gross definition of the requirements for the mechanical components of the various systems, making possible to evaluate their main expected parameters such as mass, size and actuators workspace.

## References

- [1] K. Wormnes, R. Le Letty, L. Summerer, R. Schonenborg, O. Dubois-Matra, E. Luraschi, A. Cropp, H. Krag and J. Delaval, ESA technologies for space debris remediation. In: Proceedings of the 6th European Conference on Space Debris, Darmstadt, 2013.
- [2] N. Johnson, E. Stansbery, D. O. Whitlock, K. J. Abercromby, D- Shoots, History of On-Orbit Satellite Fragmentations, 14th Edition, JSC-29517, NASA Johnson Space Center, Houston, TX, 2001.
- [3] J. Cook, V. Aksamentov, T. Hoffman, ISS Interface Mechanism and Their Heritage, AIAA SPACE 2011 Conference & Exposition, Sep. 2011; pp. 1-58.
- [4] M. Hardt, C. Mas, A. Ayuso, D. Cocho, L. Mollinedo, O. Gracia, and P. Urmston., Validation of space vehicle docking with the international berthing & docking mechanism and a Kuka robot, In 14th European Space Mechanisms and Tribology Symposium, Konstanz, 2011.



- [5] S. Christiansen, T. Nilson, Docking system mechanism utilized on orbital express program, Proc. 39th Aerosp. Mech. Symp., May 2008; pp. 207-220.
- [6] P. Rank, Q. Mühlbauer, W. Naumann, K. Landzettel, The DEOS Automation and Robotics payload, Proc. of the Symposium on Advanced Space Technologies in Robotics and Automation (ASTRA), the Netherlands, 2011.
- [7] Biesbroek, R., Soares, T., Husing, J., Innocenti, L., The e.deorbit cdf study: a design study for the safe removal of a large space debris. In: ESA Special Publication, 2013; p. 79.
- [8] A. Medina, A. Tomassini, M. Suatoni, et al., Towards a standardized grasping and refuelling on-orbit servicing for GEO spacecraft, Acta Astronaut., 2017; 134, pp. 1-10.
- [9] M. Shan, J. Guo, E. Gill, Review and comparison of active space debris capturing and removal methods, Prog. Aerosp. Sci., Jan. 2016; vol. 80, pp. 18-32.
- [10] European Space Agency ITT: e.Deorbit and the Space Servicing Vehicle, Clean Space Industrial Days; 2018, pp.24-27. URL: <https://indico.esa.int/event/234/contributions/4033/>
- [11] Biondi, G., Mauro, S., Mohtar, T., Pastorelli, S., Sorli, M., Feature-based estimation of space debris angular rate via compressed sensing and Kalman filtering, (2016) 3rd IEEE International Workshop on Metrology for Aerospace, MetroAeroSpace 2016 - Proceedings, pp. 215-220, Firenze (I), June 22-23, 2016, DOI 10.1109/MetroAeroSpace.2016.7573215
- [12] S. Segal, A. Carmi, P. Gurfil, "Stereo-vision-Based Estimation of Relative Dynamics Between Noncooperative Satellites: Theory and Experiments," Control Systems Technology, IEEE Transactions on, vol. 22(2), 2014, pp. 568-584.
- [13] W. Fehse, Automated Rendezvous and Docking of Spacecraft (Cambridge Aerospace Series), Cambridge: Cambridge University Press, 2003.
- [14] Mohtar, T., Cernusco, A., Mauro, S., Pastorelli, S., Sorli, M., Docking mechanism for the STRONG mission: Design, mathematical modeling, and experimental testing, (2017) Proceedings of the International Astronautical Congress, IAC, 15, pp. 9845-9853.
- [15] V. Martinot, G. Lutz, P. Pellegrino, C. Billot, Design for Removal Final Report, ThalesAlenia Space, April 2017.
- [16] T. Mohtar, S. Mauro, S. Pastorelli, M. Sorli, Predesign of an active central mechanism for space docking, Proc. of 67th International Astronautical Congress, Guadalajara, Mexico, Sep. 26-30 2016.
- [17] M. Huang, Vehicle crash mechanics, CRC Press LLC, Boca Raton, Florida, 2002.
- [18] T. Mohtar, A. Cernusco, S. Mauro, S. Pastorelli, M. Sorli, Docking mechanism concepts for the STRONG mission, Proc. of 66th International Astronautical Congress, Jerusalem, Israel, Oct. 12-16, 2015.