

Saudi Arabian Kindergarten Teachers' Self-Efficacy, Attitudes, and Perceptions of Barriers Towards Inclusive Education

Samia Alzahrani

Submitted for the Award of

Doctor of Philosophy in the School of Education

Western Sydney University

April 2021

Dedication

To the soul of my father, who was the first person to call me Dr Samia even before starting my PhD study.

To my mother, your prayers have brought me to where I am today.

To my husband, you have truly been the *wind beneath my wings*.

To my lovely daughter, you will always be the miracle that makes my life complete.

To my sisters and brothers, you are my forever friends, *you* have been there through all the good times and bad.

ACKNOWLEDGMENTS

First of all, my gratitude and praise go to Allah for granting me strength and patience throughout this journey.

I can hardly find the words to express my gratitude to my supervisors, Associate Professor Katrina Barker and Associate Professor Danielle Tracey, for their excellent supervision, guidance, energy and suggestions, valuable time and unlimited support. I would also like to thank the staff at the School of Education at Western Sydney University, and Dr Russell Thomson for his statistical advice with the data analysis for this research. I am grateful to the Saudi kindergarten teachers, kindergarten principals and staff at the Ministry of Education in Saudi Arabia for their assistance in conducting this research. My special thanks also go to Taif University for providing the financial support to study in Australia. My thanks to Justine McNamara for her professional proofreading of this thesis.

My deepest gratitude goes to the greatest love of my life, my mother Norah, for her never-ending love and prayers that have embraced and comforted me during this journey.

My best friend and beloved husband, Saleh—I don't even know where to begin to express my gratitude for your unconditional love, encouragement and endless support to achieve my goal. You always stood by me throughout this roller-coaster journey.

I owe a special measure of gratitude to you, my sweet miracle daughter Danah, for your encouraging smiles and endless hugs throughout this journey. You are my source of strength.

I also thank my wonderful sisters and brothers for their encouragement throughout my studies.

My friend Maha Alzaidi, together we started this journey and made a pact to get through it, and we did. Thank you for being such a supportive and giving friend through all this.

I would also like to thank all my friends here in Sydney and Saudi Arabia for their support and love.

STATEMENT OF AUTHENTICATION

The work presented in this thesis is, to the best of my knowledge and belief, original except as acknowledged in the text. I hereby declare that I have not submitted this material, either in full or in part, for a degree at this or any other institution.

Table of Contents

DEDICATION	2
STATEMENT OF AUTHENTICATION	4
LIST OF TABLES	11
LIST OF FIGURES	14
ABSTRACT	15
CHAPTER 1: INTRODUCTION	1
1.1 BACKGROUND OF THE STUDY	1
<i>1.1.1 Teachers' Self-Efficacy</i>	4
<i>1.1.2 Teachers' Attitudes</i>	5
<i>1.1.3 Factors Influencing Teachers' Self-Efficacy and Attitudes</i>	6
<i>1.1.4 Teachers' Perceptions of Barriers to Inclusive Education</i>	7
1.2 THESIS STRUCTURE	10
CHAPTER 2: CONTEXT OF SAUDI ARABIA AND INCLUSIVE KINDERGARTEN	
EDUCATION	12
2.1 INTRODUCTION.....	12
2.2 CONTEXT OF THE STUDY SITE: SAUDI ARABIA.....	12
2.3 PREVALENCE OF CHILDREN WITH DISABILITIES IN SAUDI ARABIA.....	13
2.4 KINDERGARTEN EDUCATION IN SAUDI ARABIA: HISTORY AND CURRENT POLICY.....	15
2.5 INTERNATIONAL INCLUSIVE KINDERGARTEN EDUCATION: HISTORY AND CURRENT POLICIES	19
2.6 INCLUSIVE KINDERGARTEN EDUCATION IN SAUDI ARABIA: HISTORY AND CURRENT POLICIES	22
2.7 SUMMARY	27

CHAPTER 3: TEACHERS’ SELF-EFFICACY AND ATTITUDES TOWARDS INCLUSIVE EDUCATION: A LITERATURE REVIEW OF THEORY, MEASUREMENT, AND EMPIRICAL RESEARCH	29
3.1 INTRODUCTION.....	29
3.2 THEORETICAL FRAMEWORKS	29
3.3 TEACHERS’ SELF-EFFICACY IN INCLUSIVE EDUCATION	35
3.3.1 <i>Measuring Teacher Self-Efficacy in Inclusive Education</i>	37
3.4 TEACHERS’ ATTITUDES TOWARDS INCLUSIVE EDUCATION.....	39
3.4.1 <i>Measuring Teachers’ Attitudes Towards Inclusive Education</i>	44
3.5 FACTORS INFLUENCING TEACHERS’ SELF-EFFICACY AND ATTITUDES TOWARDS INCLUSIVE EDUCATION	46
3.5.1 <i>Teacher-Related Factors: Teachers’ Age</i>	47
3.5.2 <i>Teacher-Related Factors: Teachers’ Teaching Position</i>	49
3.5.3 <i>Teacher-Related Factors: Years of Teaching Experience</i>	50
3.5.4 <i>Teacher-Related Factors: Teachers’ Training</i>	52
3.5.5 <i>Teacher-Related Factors: Having a Family Member, Close Relative, or Friend With a Disability</i>	54
3.5.6 <i>Child-Related Factors: Type of Disability and Severity</i>	55
3.5.7 <i>Context-Related Factors: Physical and Personnel Support</i>	58
3.6 TEACHERS’ PERCEPTIONS OF BARRIERS TO INCLUSIVE EDUCATION	60
3.7 SUMMARY	62
CHAPTER 4. RESEARCH AIMS, RATIONALE, AND QUESTIONS	64
4.1 INTRODUCTION.....	64
4.2. STATEMENT OF THE PROBLEM.....	64
4.3. RESEARCH AIMS, RATIONALE, AND QUESTIONS.....	65
4.3.1. <i>Research Aim 1</i>	65
4.3.2. <i>Research Aim 2</i>	67
4.3.3. <i>Research Aim 3</i>	69

4.3.4. <i>Research Aim 4</i>	72
4.4. SIGNIFICANCE OF THE STUDY	74
4.5 SUMMARY	75
CHAPTER 5: METHODOLOGY.....	76
5.1 INTRODUCTION	76
5.2 RESEARCH DESIGN	76
5.3 PARTICIPANTS	80
5.3.1 <i>Questionnaire Participants</i>	80
5.3.2 <i>Semi-structured Interview Participants</i>	83
5.4 INSTRUMENTATION.....	84
5.4.1 <i>Questionnaire</i>	84
5.4.2 <i>Semi-structured Interview</i>	90
5.5 PROCEDURE.....	91
5.5.1 <i>Questionnaire Procedure</i>	91
5.5.2 <i>Semi-structured Interview Procedure</i>	93
5.6 ANALYSIS OF DATA.....	94
5.6.1 <i>Analysis of Quantitative Data</i>	94
5.6.2 <i>Analysis of Qualitative Data</i>	101
5.7 ETHICAL CONSIDERATIONS	109
5.8 SUMMARY	109
CHAPTER 6: INSTRUMENT VALIDITY AND RELIABILITY RESULTS.....	111
6.1 INTRODUCTION.....	111
6.2 PRELIMINARY ANALYSES	112
6.2.1 <i>Checking for Outliers</i>	112
6.2.2 <i>Assessing Normality</i>	115
6.3. TESTING FOR VALIDITY AND RELIABILITY OF THE ADAPTED TEACHER EFFICACY FOR INCLUSIVE PRACTICES (TEIP) SCALE.....	118
6.3.1 <i>Validity Analysis of the Adapted TEIP Scale</i>	118

6.3.2. <i>Reliability Analysis of the Adapted TEIP Scale</i>	128
6.4. TESTING FOR VALIDITY AND RELIABILITY OF THE ADAPTED OPINIONS RELATIVE TO THE INTEGRATION OF STUDENTS WITH DISABILITIES (ORI) SCALE	130
6.4.1 <i>Validity Analysis of the Adapted ORI Scale</i>	131
6.4.2 <i>Reliability Analysis of the Adapted ORI Scale</i>	140
6.5 SUMMARY	141
CHAPTER 7: RESULTS OF THE QUESTIONNAIRE ANALYSES	142
7.1 INTRODUCTION	142
7.2 TEACHERS' SELF-EFFICACY AND ATTITUDES TOWARDS INCLUSIVE EDUCATION	143
7.2.1 <i>Examining Kindergarten Teachers' Self-Efficacy in Inclusive Education</i>	143
7.2.2 <i>Examining Kindergarten Teachers' Attitudes Towards Inclusive Education</i>	144
7.2.3 <i>Examining the Differences in the Self-Efficacy Between General and Special Education Teachers</i>	145
7.2.4 <i>Examining Differences in the Attitudes of General and Special Education Teachers</i>	148
7.2.5 <i>Examining the Relationship between Teachers' Self-Efficacy and Attitudes</i>	149
7.3 TEACHER-RELATED FACTORS ASSOCIATED WITH TEACHERS' SELF-EFFICACY AND ATTITUDES ..	152
7.3.1 <i>Examining the Influence of Teacher-related Factors on Self-Efficacy of Teachers</i>	152
7.3.2 <i>Examining the Influence of Teachers Related Factors on Attitudes of Teachers</i>	159
7.4 CHILD-RELATED FACTORS ASSOCIATED WITH TEACHERS' SELF-EFFICACY AND ATTITUDES	165
7.4.1 <i>Examining the Influence of Child-related Factors on Self-Efficacy of Teachers</i>	165
7.4.2 <i>Examining the Influence of Child-Related Factors on Attitudes of Teachers</i>	167
7.5 CONTEXT-RELATED FACTORS ASSOCIATED WITH TEACHERS' SELF-EFFICACY AND ATTITUDES .	169
7.5.1 <i>Examining the Influence of Context-related Factors on Self-Efficacy of Teachers</i>	169
7.5.2 <i>Examining the Influence of Context-related Factors on Attitudes of Teachers</i>	175
7.6. TEACHERS' PERCEPTIONS OF BARRIERS TO INCLUSIVE EDUCATION	179
7.7 SUMMARY	181
CHAPTER 8: RESULTS OF THE QUALITATIVE ANALYSES	183
8.1 INTRODUCTION	183

8.2. CHARACTERISTICS OF INTERVIEW PARTICIPANTS.....	184
8.3 RESULTS.....	185
8.3.1 <i>Factors Influencing Teachers' Positive Self-Efficacy</i>	186
8.3.2 <i>Factors Influencing Teachers' Less Positive Self-Efficacy</i>	189
8.3.3 <i>Factors Influencing Teachers' Positive Attitudes</i>	192
8.3.4 <i>Factors Influencing Teachers' Less Positive Attitudes</i>	196
8.3.5 <i>Reported Barriers to Inclusive Education</i>	199
8.4 SUMMARY	209
CHAPTER 9: DISCUSSION OF FINDINGS, RECOMMENDATIONS, AND CONCLUSIONS	211
9.1 INTRODUCTION	211
9.2 DISCUSSION OF FINDINGS	211
9.2.1 <i>Validity and Reliability of the Adapted TEIP and ORI Scales</i>	211
9.2.2 <i>Levels Of Teachers' Self-Efficacy and Attitudes, Differences Between General and Special Education Teachers, and the Relationship Between Self-Efficacy and Attitudes</i>	218
9.2.3 <i>Factors Influencing Teacher's Self-Efficacy and Attitudes Towards Inclusive Education</i> ...	225
9.3 TEACHERS' PERCEPTIONS OF BARRIERS TO INCLUSIVE EDUCATION	249
9.4 STRENGTHS OF THE CURRENT STUDY.....	258
9.5 LIMITATIONS OF THE CURRENT STUDY	260
9.6 IMPLICATIONS FOR FUTURE RESEARCH	260
9.7 RECOMMENDATIONS FOR THE MINISTRY OF EDUCATION	262
9.8 CONCLUSION	267
REFERENCES	270
APPENDICES	299
APPENDIX A	300
APPENDIX B	309
APPENDIX C	319
APPENDIX D	320

APPENDIX E324

APPENDIX F.....327

LIST OF TABLES

Table 2.1	Saudi Population With and Without Disabilities by Age Group and Sex
Table 2.2	Summary of the Numbers of Children with Different Types of Disabilities
Table 5.1	Summary of Demographic Information of Questionnaire Participants
Table 5.2	Examples of the Adapted TEIP Scale Items for Each Factor
Table 5.3	Examples of the Adapted ORI Scale Items for Each Factor
Table 5.4	Coding of Categorical Variables in the Multiple Regression Analysis
Table 6.1	Test of Normality for the Adapted TEIP and ORI Scales
Table 6.2	Goodness-of-Fit Summary for Initial Model of the Adapted TEIP Scale
Table 6.3	Goodness-of-Fit Summary for the Final Model of the Adapted TEIP Scale
Table 6.4	Inter-item Correlations for the Adapted TEIP Scale
Table 6.5	Correlations Among the Three Latent Constructs of the Adapted TEIP Scale
Table 6.6	Cronbach's Alpha Values for the Adapted TEIP Scale
Table 6.7	Goodness-of-Fit Summary for Initial Model of the Adapted ORI Scale
Table 6.8	Goodness-of-Fit Summary for Final Model of the Adapted ORI Scale
Table 6.9	Inter-item Correlations for the Adapted ORI Scale
Table 6.10	Correlations Among the Three Latent Constructs of the Adapted ORI Scale
Table 6.11	Cronbach's Alpha Values for the Adapted ORI Scale
Table 7.1	Means and Standard Deviations of Teachers' Self-Efficacy Towards Inclusive Education
Table 7.2	Means and Standard Deviations of Teachers' Attitudes Towards Inclusive Education
Table 7.3	T-Test results for General and Special Education Teachers' Self-Efficacy

Table 7.4	T-Test Results for General and Special Education Teachers' Attitudes
Table 7.5	Relationship Between Teachers' Self-Efficacy and Their Attitudes
Table 7.6	ANOVA of the Multiple Regression for Teacher-related Factors Influencing the Total Self- Efficacy Scale and its Three Factors
Table 7.7	Multiple Regression Model Summary for Teacher-related Factors Influencing the Total Self- Efficacy Scale and its Three Factors
Table 7.8	Summary of Multiple Regression for Teacher-related Factors Influencing the Total Self- Efficacy Scale Model and its Three Factors
Table 7.9	ANOVA of the Multiple Regression Model for Teacher-related Factors Influencing the Attitudes Total Scale and its Three Factors
Table 7.10	Multiple Regression Summary Model for Teacher-related Factors Influencing the Attitudes Total Scale and its Three Factors
Table 7.11	Summary of Multiple Regression for Teacher-related Factors Influencing the Attitudes Total Scale and its Three Factors
Table 7.12	Teachers' Reported Levels of Confidence for Including Children with Specific Disabilities
Table 7.13	Friedman Test for the Difference Among the Ranked Types of Disability
Table 7.14	Means and Standard Deviations of Teachers' Attitudes Towards Inclusion of Children with Specific Types of Disabilities
Table 7.15	ANOVA of the Multiple Regression Model for Context-related Factors Influencing the Self-Efficacy Total Scale and its Three Factors
Table 7.16	Multiple Regression Summary Model for Context-related Factors Influencing the Self-Efficacy Total Scale and its Three Factors
Table 7.17	Summary of Multiple Regression for Context-related Factors Influencing the Self-Efficacy Total Scale and its Three Factors
Table 7.18	ANOVA of the Multiple Regression Model for Context-related Factors Influencing the Attitudes Total Scale and its Three Factors
Table 7.19	Multiple Regression Summary Model for Context-related Factors Influencing the Attitudes Total Scale its Three Factors
Table 7.20	Summary of Multiple Regression for Context-related Factors Influencing the Attitudes Total Scale and its Three Factors
Table 7.21	Teachers' Mean Ranking of Barriers to Including Children with Disabilities in Inclusive Kindergarten Classrooms

Table 7.22 Result of a Friedman Test for the Difference Among the Ranked Barriers to Inclusion of Children with Disabilities in Inclusive Kindergarten Classrooms

Table 8.1 Summary of Interview Participants' Demographic Information

LIST OF FIGURES

- Figure 1.1** Application of Bronfenbrenner's Ecological Systems Theory
- Figure 6.1** Boxplot With Outliers for Teachers' Self-Efficacy (Adapted TEIP Scale)
- Figure 6.2** Boxplot With Outliers for Teachers' Attitudes (Adapted ORI Scale)
- Figure 6.3** Histogram of the Distribution of Teachers' Self-efficacy (Adapted TEIP Scale)
- Figure 6.4** Histogram of the Distribution of Teachers' Attitudes (Adapted ORI Scale)
- Figure 6.5** Initial Measurement Model for the Construct of Self-Efficacy (TEIP Scale)
- Figure 6.6** Final Measurement Model for the Construct of Self-Efficacy (Adapted TEIP Scale)
- Figure 6.7** Initial Measurement Model for the Construct of Attitudes (Adapted ORI Scale)
- Figure 6.8** Final Measurement Model for the Construct of Teachers' Attitude (Adapted ORI Scale)

ABSTRACT

Despite Saudi Arabia's national and international commitments to adopting inclusive education to educate children with disabilities, there is a dearth of studies that investigate teachers' self-efficacy and attitudes towards inclusive education in Saudi kindergarten settings and their perceptions of the barriers to inclusive education in such settings. Without this inquiry into teacher self-efficacy and attitudes and their perceptions of the barriers to inclusive education, the implementation of effective inclusive education in Saudi kindergartens remains challenging. Thus, to fill this gap in knowledge, this empirical study had four key aims. First, the study sought to verify the validity and reliability of two previously well-established measures—the Teacher Efficacy for Inclusive Practices (TEIP) scale and the Opinions Relative to the Integration of Students with Disabilities (ORI) scale—in terms of measuring both teachers' self-efficacy and their attitudes regarding inclusive education in Saudi kindergarten settings, which has not yet been achieved. Second, the study sought to elucidate Saudi teachers' self-efficacy and attitudes concerning inclusive education in kindergarten settings. Third, the study sought to investigate the influence of teacher-, child-, and context-related factors on teachers' self-efficacy and attitudes concerning inclusive education in Saudi kindergarten settings. Fourth, the study sought to explore teachers' perceptions of the barriers to the successful inclusion of children with disabilities in Saudi kindergarten settings.

To achieve these four aims, the present study applied a convergent mixed-methods design involving both quantitative (questionnaires) and qualitative (interviews) approaches. With regard to the quantitative component, self-report questionnaires were completed by a

total of 299 kindergarten teachers (237 general education teachers and 62 special education teachers) employed in inclusive public kindergartens in Riyadh, Saudi Arabia. Semi-structured interviews (i.e., the qualitative component) were then conducted with a purposive sample of eight teachers (four general education teachers and four special education teachers), who were selected on the basis of their responses to the questionnaire (i.e., whether they reported positive or less positive self-efficacy and attitudes) and their willingness to be interviewed.

Three major findings emerged from the analysis of the mixed-methods data. First, this study is the only research ever conducted to confirm the validity and reliability of the TEIP and ORI scales in the Saudi kindergarten context following necessary adaptation of the two scales.

Second, the kindergarten general and special education teachers exhibited generally somewhat positive self-efficacy and neutral attitudes towards inclusive education. Notably, the special education teachers were found to exhibit higher self-efficacy and attitudes across the TEIP and ORI scales and the related factors relative to the general education teachers. A strong positive and statistically significant relationship was identified between teachers' self-efficacy and their attitudes towards inclusive education.

Third, the findings of both the quantitative analysis of the questionnaires and the qualitative analysis of the interviews demonstrated the influence of teacher-, child-, and context-related factors on teachers' self-efficacy and attitudes towards inclusive education. The multiple regression analysis indicated that teacher-related factors (i.e., age, teaching position) and context-related factors (i.e., class size) had a statistically significant influence on both teachers' self-efficacy and teachers' attitudes, while one teacher-related factor (i.e., experience in inclusive education) had a statistically significant influence solely on teachers'

attitudes concerning inclusive education. With regard to the assessed child-related factors, the ranking and descriptive analysis indicated that the teachers tended to self-report higher positive self-efficacy and attitudes concerning the inclusion of children with speech and language disorders, hearing disabilities, learning disabilities, physical disabilities, and visual disabilities. However, the teachers tended to self-report lower self-efficacy and attitudes concerning the inclusion of children with behavioural disorders, autism, intellectual disabilities, and multiple disabilities.

The qualitative interview findings facilitated a deeper understanding of those factors that influence teachers' self-reporting of both positive and less positive self-efficacy and attitudes towards inclusive education. On the one hand, factors found to foster higher positive self-efficacy on the part of teachers included encouragement from the Principal and parents, teachers' passion and enthusiasm, collaboration with special education teachers, and the achievements of children with disabilities. On the other hand, factors found to foster less positive self-efficacy among teachers included a lack of knowledge and experience, a lack of collaboration with the Principal and special education teachers, and the need to teach outside their area of specialisation. Furthermore, factors found to foster higher positive attitudes towards inclusive education included witnessing children's progress and growth, empathy for the families of children with disabilities, and work-related enjoyment. In contrast, factors found to foster less positive attitudes included the detrimental effects of inclusion on children with and without disabilities and the type and severity of the children's disabilities.

Fourth, the quantitative and qualitative findings of this study indicated the kindergarten teachers perceived several barriers to the successful delivery of inclusive education in their kindergartens. Reported barriers included the nature and severity of the

child's disability, the absence of special aides in inclusive classrooms, large class size, a perceived lack of effective professional training, a perceived lack of collaboration between general and special education teachers, discrepancies between the salaries of general and special education teachers, a perceived lack of support from Principals, and inappropriate physical environments within kindergartens.

The present study is the first of its kind in Saudi Arabia to provide rigorous psychometric testing of the TEIP and ORI scales and this strengthens not only the current study findings but supports future research on teachers' self-efficacy and attitudes towards inclusive education in Saudi kindergarten settings. Further, this study is the first in Saudi Arabia to provide valuable insights into the self-efficacy and attitudes of Saudi kindergarten teachers with regard to inclusive education; the teacher-, child-, and context-related factors that influence teachers' self-efficacy and attitudes in this regard; and the perceived barriers to the successful inclusion of children with disabilities in Saudi kindergarten settings. Moreover, this study used a convergent mixed-methods design to provide rich and in-depth data to address the research aims and questions. As such, the findings of the present study provide important recommendations to enhance inclusive education policies and practices within kindergarten settings and to develop an education system that provides the required support and resources for teachers to meet the needs of children with disabilities in inclusive kindergarten settings, which will enhance future educational outcomes for Saudi Arabia.

Chapter 1: Introduction

This study examines Saudi kindergarten teachers' self-efficacy and attitudes towards inclusive education. It also examines the teacher-, child-, and context-related factors influencing teachers' self-efficacy and attitudes and how they perceive barriers to inclusive education in Saudi kindergarten settings. In the context of the current study, inclusive education refers to the education of all children, including children with disabilities, in regular kindergarten classrooms together with the appropriate support services (Ministry of Education, 2019d).

As an introduction to the study, this chapter provides a brief overview of the general field, an explanation of its importance, and an outline of the thesis structure and focus for each chapter.

1.1 Background of the Study

Over the past three decades, many shifts have occurred in the provision of education for children with disabilities around the world. Traditionally, children with disabilities were not enrolled in education at all, and once enrolment became available, they were automatically enrolled in segregated settings because they were deemed to require education that was different and separate from their peers (Kavale, 2002). However, several concerns have been voiced about the detrimental implications of excluding members of a community from the general educational setting of their community (Bunch & Valeo, 2004). The legitimacy of these concerns has been recognised by the implementation of alternative approaches to segregated settings; these alternatives involve integration and inclusive education.

The use of the term “integration” preceded that of “inclusive education.” Integration is “the schooling of children with disabilities in the least restrictive setting” (Thomazet, 2009, p. 553). In practice, integration is a process whereby certain children with disabilities are placed into a special class within the regular educational setting and join their peers outside the classroom during sporting activities and recess (Winzer, 2009). By contrast, inclusive education is defined as “a fundamental human right and process of systemic reform in education that aims to eliminate barriers, enabling all students to participate in learning experiences with their same-aged peers.” (Graham, 2020, p. xxi).

The aspiration of including children with disabilities in regular kindergarten settings can be attributed to several governmental policies and acts. For example, the Division for Early Childhood (DEC) and the National Association for the Education of Young Children (NAEYC), who formulated a joint statement (DEC/NAEYC, 2009) that inclusive education in early childhood entails “the values, policies and practices that support the right of every infant and young child and his or her family, regardless of ability, to participate in a broad range of activities and contexts as full members of families, communities and society” (p. 2).

Saudi Arabia, the context of this study, has made a commitment to inclusive education for children with disabilities through national and international agreements (Al-Mousa, 2007; United Nations, 2006). The country’s first attempt to include children with disabilities took place in 1990 in the city of Riyadh in the King Saud University Kindergarten (Al-Mousa et al., 2008). Children with a range of disabilities were included in Saudi public kindergartens, which indicated progress and increasing interest in extending inclusive education in kindergarten settings (Khashrami, 2010).

Inclusive education in kindergarten settings can have a positive impact on all children's cognitive and social development (Deiner, 2013). Children with disabilities can learn alongside their typically developing peers as members of the community, build their cognitive development skills, develop a greater sense of self and belonging to the broader community, and build friendships with others (Deiner, 2013; Little, 2020). Moreover, inclusive kindergartens can offer all children opportunities to learn to collaborate and empathise, to care for and respect others, to create understanding and respect diversity, and to appreciate their differences, families and cultures (Deiner, 2013). Thus, all kindergarten children can benefit from sharing educational experiences with each other, regardless of their needs and abilities.

Classroom teachers in inclusive kindergarten settings play an essential role in conferring those benefits on children and creating equal and appropriate educational environments for all children (Little, 2017; Odom et al., 2011). They are also deemed critical to the success of an inclusive program being implemented in educational settings (UNESCO, 2005).

Previous research indicates that teachers' high self-efficacy in inclusive practices (Sharma et al., 2012), and teachers' positive attitudes towards inclusive education (Avramidis & Norwich, 2002; De Boer et al., 2011) are the most crucial contributing factors to effective inclusive practice (Avramidis & Norwich, 2002; De Boer et al., 2011; Sharma et al., 2012; Savolainen et al., 2020). Therefore, this research focuses centrally on understanding these factors and what drives them.

1.1.1 Teachers' Self-Efficacy

Most research in the educational context defines teachers' self-efficacy as a "teacher's belief in his or her capability to organize and execute courses of action required to successfully accomplish a specific teaching task in a particular context" (Tschannen-Moran et al., 1998, p. 233). Although several studies worldwide have examined teachers' self-efficacy in general, few studies have examined this in inclusive education (Sharma et al., 2012), particularly in kindergarten settings (Francois, 2020). It has been suggested that when teachers have a high level of self-efficacy in inclusive practices, they are more confident and willing to follow effective inclusive teaching and instructional practices, collaborate with other teachers and children's parents, and identify different ways in which they could more effectively manage behaviours and meet children's needs in inclusive settings (Sharma et al., 2012). Conversely, when teachers have a low level of self-efficacy, they spend more time on non-academic tasks and ineffective inclusive teaching strategies that inhibit children's learning (Savolainen et al., 2012; Sharma, et al., 2012).

In the context of kindergarten settings, only a few studies exist worldwide that examine kindergarten teachers' self-efficacy in inclusive education, with the vast majority of these focusing on primary and secondary settings. Generally, these few existing international studies have demonstrated that kindergarten teachers have high self-efficacy in inclusive practices which may positively influence their implementation of inclusive education (Emam & Mohamed, 2011; Özokcu, 2018a; Sari et al., 2009). In Saudi Arabia, however, no studies have examined Saudi teachers' self-efficacy in inclusive education in kindergarten settings. Therefore, this study aimed to conduct this research since implementing effective inclusive education in Saudi kindergarten settings will remain challenging unless an understanding of kindergarten teachers' self-efficacy in inclusive education can be gained.

1.1.2 Teachers' Attitudes

Attitude refers to “a latent disposition or tendency to respond with some degree of favourableness or unfavourableness to a psychological object” (Fishbein & Ajzen, 2010, p. 76). Overall, the positivity of an individual’s attitude towards a particular type of behaviour is directly proportional to the individual’s intention of exhibiting that behaviour (Ajzen, 1991). The effect of attitude on behaviour applies to teachers’ attitude towards inclusive education and their teaching behaviour to implement inclusive education. The importance of teachers’ attitudes is due to their potential influence on the deployment of strategies for children with disabilities. Teachers’ positive attitudes are essential to effective inclusive education (Avramidis & Norwich, 2002; De Boer et al., 2011; Forlin et al., 2010; Woodcock, 2021). In contrast, negative attitudes of teachers may limit their acceptance of children with disabilities in regular classrooms and contribute to low expectations of learners’ achievement (Avramidis & Norwich, 2002; De Boer et al., 2011; Forlin et al., 2010; Smith & Smith, 2000).

Similar to the study of self-efficacy, few studies have been conducted in kindergarten settings to assess teachers’ attitudes towards inclusive education. Of the few studies available, some have demonstrated that kindergarten teachers espoused a positive attitude towards inclusive education (Batu et al., 2017; Bryant, 2018; Dias & Cadime, 2016; Hsieh & Hsieh, 2012; Leatherman, 2007; Štemberger & Kiswarday, 2018) while the remaining few studies found that kindergarten teachers’ attitudes were neither positive nor negative towards inclusive education (Özokcu, 2018b; Sari et al, 2009). To date, in Saudi Arabia, no studies have examined Saudi teachers’ attitudes towards inclusive education in kindergarten settings. Therefore, as it is essential to understand the attitudes of teachers in order to establish effective inclusive educational settings, the current study aimed to examine this.

1.1.3 Factors Influencing Teachers' Self-Efficacy and Attitudes

Research has found that teachers' self-efficacy and attitudes towards inclusive education can be influenced by several factors (e.g., Batu et al., 2017; Chiner & Cardona, 2013; Dias & Cadime, 2016; Emam & Mohamed 2011; Lee et al., 2014; Parasuram, 2006; Štemberger and Kiswarday, 2018; Özokcu, 2018a; You et al., 2019). These factors can be divided as follows: (a) teacher-related factors, including teacher's age, teaching position, teaching experience, training, and having a family member or close relative or friend with a disability; (b) child-related factors, including children's types of disabilities and severity; and (c) context-related factors, including physical supports (availability of resources, materials, and equipment, number of children in the classrooms/class size, classroom time, and education policy support) and personnel support (availability of special aides/teacher assistants and collaboration with other teachers, administrators, and parents).

In the kindergarten context, most of the few existing international studies have shown mixed results with regard to the influence of teacher-related factors on kindergarten teachers' self-efficacy and attitudes towards inclusive education (Batu et al., 2017; Dias & Cadime, 2016; Emam & Mohamed 2011; Fakhri, 2019; Lee et al., 2015; Parasuram, 2006; Özokcu, 2018a; Štemberger & Kiswarday, 2018; You et al., 2019). Furthermore, there have been limited international research studies on the influence of the type and severity of children's disabilities on kindergarten teachers' self-efficacy. The few international studies conducted in primary and secondary settings that have examined the influences or relationship between teachers' self-efficacy in inclusive education and the type of disability and its severity have shown inconsistent results (Hofman & Kilimo, 2014; Yada & Savolainen, 2019). Regarding teachers' attitudes, few international studies have examined the influence of the type and severity of children's disabilities on kindergarten teachers' attitudes towards inclusive education (Batu et al., 2017; Fakhri, 2019; Gezer & Aksoy, 2019)

and those that exist have shown inconsistent results. In addition, there has been surprisingly little international research on the relationships between or influence of context-related factors on teachers' self-efficacy and attitudes towards inclusive education in all educational levels, including kindergarten. The findings of the limited existing studies have generally indicated that teachers who perceive sufficient physical and personnel support held more positive self-efficacy and attitudes towards inclusive education than teachers who did not believe they had sufficient support (Chiner & Cardona, 2013; Fyssa et al., 2014; Hosford & O'Sullivan, 2016).

In Saudi Arabia, no empirical studies have examined the influence of teacher, child, and context-related factors on Saudi kindergarten teachers' self-efficacy and attitudes towards inclusive education. Thus, the current study aimed to advance knowledge in the national and international literature by investigating these influences.

1.1.4 Teachers' Perceptions of Barriers to Inclusive Education

It has been stressed that for inclusive education to be effective, teachers' concerns about the barriers to implementing inclusive education in their regular classrooms must be recognised and addressed (Alhammad, 2017; Bhatnagar & Das, 2014; Forlin et al., 2010; Sharma et al, 2019; Woodcock & Woolfson, 2019). In the context of kindergarten settings, there is a dearth of existing international research on kindergarten teachers' perceptions of barriers to inclusive education. From this limited research the various barriers that have been identified by teachers include a lack of support from Principals and parents; a lack of collaboration between teachers; insufficient financial, physical and personnel resources; inadequate policy support; and a negative understanding of disabilities (Chiner & Cardona, 2013; Fyssa et al., 2014; Gezer & Aksoy, 2019; Purdue, 2009; Smith & Smith, 2000). In Saudi Arabia there is an absence of research on kindergarten teachers' perception of barriers

to inclusive education in Saudi kindergarten settings. Thus, the current study aimed to fill the gap in Saudi literature and add knowledge to the international literature on this subject.

Of the few existing international studies on kindergarten teachers' self-efficacy and attitudes towards inclusive education, the factors influencing their self-efficacy and attitudes, or their perceptions of the barriers to inclusive education, most used a single method—quantitative or qualitative—and only a very small number of studies employed mixed methods. Thus, the current study avoided the methodological limitations of previous studies by employing a convergent mixed-methods approach to comprehensively address this study's aims and questions. This mixed-methods design help produce a more complete and verified account of the topic under investigation than would have been provided by adopting only one method (Creswell & Plano Clark, 2018).

Considering the new changes in inclusive kindergarten settings that the Saudi Ministry of Education aims to achieve in the Saudi Vision 2030 (which focuses efforts towards achieving a society that is inclusive and enabling, providing equality and the opportunity for each person to fulfil their potential) (Vision 2030, n.d.-a), now is an optimal time to examine and understand teachers' self-efficacy and attitudes towards inclusive education in kindergarten settings. An investigation of teacher-, child- and context-related factors influencing teachers' self-efficacy and attitudes and teachers' perception of the barriers to inclusive education in kindergarten settings is also timely. This study, therefore, is the first in Saudi Arabia to advance knowledge and provide empirical research on kindergarten teachers' self-efficacy and attitudes towards inclusive education, the factors influencing their self-efficacy and attitudes, and their perception of the barriers to inclusive education in kindergarten settings.

Using a convergent mixed-methods design, the current study was concerned with achieving four cascading research aims. The first aim was to verify for Saudi kindergarten settings the validity and reliability of two adapted, pre-existing and well-established scales: the Teacher Efficacy for Inclusive Practices (TEIP) scale (Sharma et al., 2012), for measuring teachers' self-efficacy in inclusive education; and the Opinions Relative to the Integration of Students with Disabilities (ORI) scale (Antonak & Larrivee, 1995), for measuring teachers' attitudes towards inclusive education in Saudi kindergarten settings. The second aim was to investigate Saudi teachers' level of self-efficacy and attitudes towards inclusive education in kindergarten settings. The third aim was to investigate the influence of teacher-, child- and context-related factors on teachers' self-efficacy and on teachers' attitudes towards inclusive education in Saudi kindergarten settings. The fourth and final aim was to explore teachers' perception of barriers to successfully including children with disabilities in Saudi kindergarten settings.

The present investigation extends current understanding by providing psychometric information on the adapted scales that can be used to strengthen the current study's findings and to support future research on teachers' self-efficacy and attitudes towards inclusive education in the kindergarten context. Furthermore, this study is the first in Saudi Arabia to provide insights on Saudi kindergarten teachers' self-efficacy and attitudes towards inclusive education, on teacher-, child-, and context-related factors that influence Saudi kindergarten teachers' self-efficacy and attitudes and on teachers' perceptions of the barriers to inclusive education in Saudi kindergarten settings. Using the findings from this study, the Ministry of Education may develop and implement strategies to enhance Saudi kindergarten teacher self-efficacy and attitudes, and thus improve inclusive education programs in kindergarten settings. Additionally, this study may also contribute to a better understanding of inclusive education in Saudi kindergarten settings, as it will offer a cultural perspective

on teachers' self-efficacy and attitudes towards inclusive education and children with disabilities in the context of an Arab-Muslim culture. Moreover, as this study will be the first of its kind in Saudi Arabia, the outcome of the study may also provide a stimulus for further research on inclusive education in kindergartens settings in this country.

Major methodological limitations that have pervaded previous research were avoided by using a convergent mixed-methods approach to address the research aims, thus providing rich, in-depth data. As this design has not been a prominent feature in inclusive education research internationally, and more specifically in Saudi Arabia, this study advances methodological practice.

1.2 Thesis Structure

This thesis consists of nine chapters. Chapter 1 is the introduction, which offers a general overview of the current study. It includes the rationale for conducting the study, the research aims, and the significance of the study. Chapters 2 and 3 review bodies of literature that are central to this thesis. In Chapter 2, the literature on the context of Saudi Arabia and inclusive kindergarten education is reviewed. Chapter 3 reviews and critiques relevant theories and examines the empirical research exploring teachers' self-efficacy and attitudes towards inclusive education; teacher-, child- and context-related factors influencing teachers' self-efficacy and attitudes; and teachers' perceptions of barriers to inclusive education. Chapter 4 sets out, in detail, the four aims, their rationale, and the research questions of this thesis. In Chapter 5, the thesis then moves on to detail the methodology applied to achieve the four research aims mentioned above. Chapter 6 presents the findings from the psychometric analysis of the validity and reliability of the TEIP and ORI scales. Chapter 7 presents the findings from the analyses of the quantitative data from the questionnaire. Chapter 8 presents the findings from the analyses of the qualitative data from

the interviews. Finally, in Chapter 9, the quantitative and qualitative findings of the study are drawn together and discussed. The study's strengths and limitations are presented, along with implications for future research, and recommendations.

Chapter 2: Context of Saudi Arabia and Inclusive Kindergarten

Education

2.1 Introduction

This research aimed to explore Saudi kindergarten teachers' self-efficacy and attitudes towards inclusive education in kindergarten settings as well as the teacher-, child-, and context-related factors that influence teachers' self-efficacy and attitudes. Teachers' perceptions of the barriers to inclusive education in kindergarten settings were also investigated.

This chapter provides contextual information relevant to the current study; it presents an overview of the study site, Saudi Arabia; the prevalence of children with disabilities in Saudi Arabia; and the kindergarten education system in the country. It also reviews the history and current policies of international inclusive kindergarten education and the history and current policies of Saudi inclusive kindergarten education.

2.2 Context of the Study Site: Saudi Arabia

This study was conducted in Saudi Arabia, which is located at the crossroads of three continents—Europe, Africa, and Asia. Saudi Arabia is bounded on the north by Jordan, Iraq, and Kuwait; on the south by Yemen and Oman; on the west by the Red Sea; and on the east by the Arabian Gulf, United Arab Emirates, and Qatar. The capital city of Saudi Arabia is Riyadh, located in the middle of the country. Modern Saudi Arabia was founded in 1932 by King Abdul Aziz Al-Saud. Prior to 1932, Saudi Arabia was composed of several regions, and each region was ruled by certain tribes. These tribes were then united

by King Abdul Aziz under one nation—the Kingdom of Saudi Arabia (Royal Embassy of Saudi Arabia, Washington, DC, 2019).

According to Saudi Arabia’s General Authority for Statistics (2017), the population of Saudi Arabia was 34 million in 2017, including children. Children in the age group 0–4 years numbered 2,844,501 (8.3%), and children in the age group 5–9 years numbered 2,956,437 (8.6%) (General Authority for Statistics, 2017). Saudi Arabia’s official language is Arabic, and the official religion is Islam. The constitution of the country is based on the Holy Quran. Islam plays a key role in all Saudi sectors—from education and health to the economy, security, and policy (Council of Ministries, 2020).

2.3 Prevalence of Children with Disabilities in Saudi Arabia

The data produced by the General Authority for Statistics (2017) on disability in Saudi Arabia indicated that, among the total Saudi population of 34 million in 2017, 1,445,723 (7.1%) people had disabilities (see Table 2.1). The proportion of Saudi males with disabilities (3.7%) was greater than the proportion of females with disabilities (3.4%). As shown in Table 2.1, the number of children with disabilities for the age group 0–4 years was 26,520 (1.8% of all children in that age group) and 47,087 (3.2%) for the 5–9 years age group (General Authority for Statistics, 2017). Data from the General Authority for Statistics (2017) additionally indicated that physical disabilities were the most frequently reported type of disability among children aged 0–9 years (Table 2.2). However, there were no data on the distribution of children with disabilities aged 3–6 years enrolled in Saudi inclusive kindergarten settings for the different types of disabilities. The only data available were from the Ministry of Education (2019b), which indicated that 721 children with disabilities were enrolled in inclusive kindergarten education in 2017–2018.

Table 2.1*Saudi Population With and Without Disabilities by Age Group and Sex*

Age Groups	الجملة			لا توجد صعوبة			توجد صعوبة		
	جملة	اناث	ذكور	جملة	اناث	ذكور	جملة	اناث	ذكور
	Total	Females	Males	Total	Females	Males	Total	Females	Males
0 - 4	2171164	1065750	1105414	2144644	1052363	1092281	26520	13387	13133
5 - 9	2121775	1041985	1079790	2074688	1022828	1051860	47087	19157	27930
10 - 14	1899522	935929	963593	1839667	909806	929861	59855	26123	33732
15 - 19	1789169	878743	910426	1734739	852175	882564	54430	26568	27862
20 - 24	2018057	964084	1053973	1956667	938240	1018427	61390	25844	35546
25 - 29	1936400	957520	978880	1874835	935639	939196	61565	21881	39684
30 - 34	1747732	866098	881634	1678198	839300	838898	69534	26798	42736
35 - 39	1527519	754229	773290	1454097	729111	724986	73422	25118	48304
40 - 44	1284333	629836	654497	1203069	598064	605005	81264	31772	49492
45 - 49	1070154	520252	549902	985884	484367	501517	84270	35885	48385
50 - 54	853081	414429	438652	737475	354229	383246	115606	60200	55406
55 - 59	655841	314017	341824	533018	248230	284788	122823	65787	57036
60 - 64	479334	231687	247647	341606	164727	176879	137728	66960	70768
65 - 69	310359	159582	150777	187851	95671	92180	122508	63911	58597
70 - 74	222818	112813	110005	115906	53609	62297	106912	59204	47708
75 - 79	144079	72937	71142	58089	24823	33266	85990	48114	37876
80+	177025	91557	85468	42206	17778	24428	134819	73779	61040

Note. Reprinted from General Authority for Statistics (2017).**Table 2.2***Summary of the Numbers of Children with Different Types of Disabilities*

Age group	Visual disabilities	Hearing disabilities	Physical disabilities	Intellectual disabilities	Speech and language disabilities
0-4	1,358	730	7,880	2,507	2,882
5-9	3,660	2,490	14,513	6,481	9,028

Note. Data sourced from General Authority for Statistics (2017).

2.4 Kindergarten Education in Saudi Arabia: History and Current Policy

There are six stages of education in Saudi Arabia (Ministry of Education, 2019c): kindergarten (ages 3–6, years 1–3); elementary school (ages 6–12, years 1–6); secondary school (ages 12–15, years 1–3); high school (ages 15–18, years 1–3); undergraduate (ages 18–21, years 1–4); and postgraduate (ages 21 and above). It is not compulsory for children to attend the kindergarten stage of education.

Saudi Arabia has two educational sectors: government public schools and kindergartens, and private schools and kindergartens. The Saudi government provides public school and kindergarten education free of charge to all citizens. Students attending public schools and kindergartens are provided with learning materials and health care, while those attending private schools and kindergartens need to pay for their education. Saudi Arabia does not allow co-education except at the kindergarten stage (Ministry of Education, 1976). This means that boys and girls can attend kindergarten together; however, only women are permitted to be caregivers and teachers at this stage.

Kindergarten education has had a relatively short history in Saudi Arabia. The first public kindergarten was launched in 1966 by the Ministry of Education. After that, a number of kindergartens opened across the country (Hakim, 2012). In 2017–2018, there were 3,807 kindergartens in Saudi Arabia with 295,285 children enrolled. Of these children, 721 had disabilities (Ministry of Education, 2019b). The organisational guide for public and private kindergarten education in Saudi Arabia explains that kindergartens accept children from ages 3 to 6. The children are placed in one of three levels according to their age: kindergarten 1 for children aged 3–4 years, kindergarten 2 for ages 4–5 years, or kindergarten 3 for ages 5–6 years. The level 1 classes allow a maximum of 24 children per class, while the limit for

levels 2 and 3 is 30 children per class. Kindergarten children are expected to attend kindergarten every day for the whole day.

The required qualification for general education kindergarten teachers in Saudi Arabia is a bachelor's degree in early childhood education. Special education teachers who work in inclusive kindergartens require a bachelor's degree in special education (Ministry of Education, 2018a). Inclusive kindergartens in Saudi Arabia are defined as, the education setting of all children, including children with disabilities, in regular kindergarten classrooms together with the appropriate support services (Ministry of Education, 2019d). The national curriculum for Saudi kindergarten education is called *The Self-Learning Curriculum for Kindergarten* and comprises different educational units. These include freedom, play, flexibility, knowledge and skills, respect for identity and culture, productive relationships with families, and human interaction (Ministry of Education, 2019a).

The Ministry of Education in Saudi Arabia has set nine educational goals for public and private kindergartens to address the overall Saudi educational policy for kindergarten settings. They are described as follows:

1. Protecting the instincts of children, looking after their moral, mental and physical growth in a natural environment similar to their family environment, and responsive to the requirements of Islam.
2. Composition of the child's religious trend based on belief in the oneness of God; this conforms to the child's instincts.
3. Teaching the child good behaviour and helping him/her to acquire the virtues and expected behaviours of Islam, by providing a good example for him/her at school.

4. Familiarising the child with the school atmosphere, preparing him/her for school life and transferring him/her gently from self-centredness to a social life shared with schoolmates.
5. Providing the child with a wealth of correct expressions and easily understood fundamental truths and information that suit his/her age and are relevant to his/her surroundings.
6. Training the child in body exercises, teaching him/her sanitary habits, cultivating his/her senses, and training him/her to use them properly.
7. Encouraging the child's imaginative thinking and opening the doors for his/her energies to blossom under guidance.
8. Meeting childhood's needs, making him/her happy and educating him/her, all without spoiling or burdening him/her.
9. Protecting the child against dangers, treating the early signs of bad behaviour, and facing childhood problems in an adequate way. (Al-Jadidi, 2012, pp. 39–40)

In 2016, the Saudi government launched Vision 2030 (Vision 2030, n.d.-a), which aims to reduce Saudi Arabia's dependence on oil, diversify its economy, and expand the public service sectors, including the health, education, transportation, and tourism sectors. The Council of Economic and Development Affairs has developed 13 "Vision Realization Programs" (VRPs) to *achieve* the 96 strategic objectives of Saudi Arabia's national Vision 2030. Each VRP includes a number of initiatives and delivery plans. The quality and progress of the delivery plans and programs are assessed annually by the VRP program committees, which are under the responsibility of the Council of Economic and Development Affairs (Vision 2030, n.d.-a). One of the main VRPs of Saudi Arabia's Vision 2030 is the Human Capital Development Program. This program aims to improve the outputs of the education and training system at all educational levels—from early education

to continuous education—and to provide training that achieves international standards through the implementation of education, rehabilitation, and training programs that keep abreast of modern times and requirements, and that align with the needs of development and the local and global labour markets in partnership with all relevant parties, both locally and internationally. The program will also contribute to the development of all components of the education and training system, including teachers, trainers, faculty members, governance, evaluation systems, quality, curricula, educational and vocational paths, and the training environment for all stages of education and training to keep pace with modern and innovative trends in the fields of education and training. The program will be based on Islamic, educational, social, and professional foundations. It will introduce new educational and training policies and systems that will enhance the efficiency of human capital in line with the Kingdom’s Vision 2030 to achieve comprehensiveness, quality, and flexibility, and to serve all segments of society to promote the Kingdom’s regional leadership and international competitiveness (Vision 2030, n.d.-b, para. 1).

To meet the demands of Vision 2030, the Ministry of Education (2019a) aims to implement a number of initiatives tailored towards early childhood education. These are:

- To develop kindergartens, open new kindergartens, expand their services to include all regions of the Kingdom and raise the proportion of children’s enrolment in kindergartens from 17% to 95% by 2030.
- To ensure fair, quality, and inclusive education for all.
- To improve the regulations and policies of early childhood education.
- To build professional development programs for kindergarten teachers.

- To improve the quality of public and private kindergartens’ learning environments by using the Early Childhood Environment Rating Scale through a partnership with the King Abdulaziz University in Saudi Arabia.
- To improve the personal safety program to protect children from abuse in cooperation with the United Nations International Children’s Emergency Fund (UNICEF), aiming to enhance personal safety values and skills among children, teachers, and parents by providing a healthy educational environment and developing safety skills for various types of abuse and neglect.

These initiatives clearly show the importance of kindergarten education—and, more specifically, inclusive kindergarten education—in realising the goals of the new Saudi vision for its children so that they can become mature and well-rounded individuals.

2.5 International Inclusive Kindergarten Education: History and Current

Policies

Globally, before 1848, children with disabilities were not enrolled in education at all, and once enrolment became available, they were automatically enrolled in segregated settings because they were deemed to require education that was different to and separate from their peers (Kavale, 2002). This approach denied them access to essential educational and social opportunities. The Civil Rights Movement in the 1950s and 1960s and the “normalization principle” of the 1960s and 1970s have led to the formulation of policies in various countries to integrate children with disabilities into the general educational system (Bunch & Valeo, 2004; Peters, 2004; Skrtic, 1991). These policies include the Education for All Handicapped Children Act (1975) in the United States (currently known as the Individuals with Disabilities Education Act or IDEA). IDEA provided for the provision of free and equal educational opportunities for children aged 3 to 5 years with disabilities in

the least restrictive environment (Odom et al., 1996; Odom et al., 2004). Similar policies in the United Kingdom are reflected in the Warnock Report of 1978 and the Education Act of 1981, which both emphasised integrating children with special educational needs into regular preschool programs from age 2, with provision of special educational services (Warnock, 1979; Russell, 1984). In Australia, supporting the integration of children with disabilities into mainstream early childhood education and care (ECEC) has been an established approach since the introduction of the Australian Disability Services Act (1986), which started the first early intervention programs (Foreman, 2000; Kemp, 2016). At that period of time, children with mild to moderate disabilities were accessing mainstream ECEC services, while children with severe disabilities were still placed into special institutions (Goodfellow, 1988).

The 1994 World Conference on Special Education: Access and Quality, held in Salamanca in Spain, marked a principal step towards inclusive education. The Salamanca Statement, a product of this conference, established that the main aim of inclusive education was to ensure that all children and young people with disabilities are completely included in regular classrooms, “regardless of their physical, intellectual, social, emotional, linguistic or other conditions” (UNESCO, 1994, p. 6). This has been used as a principal conceptual framework for inclusive education policies, from 1994 to the present, in many countries (Meijer & Watkins, 2019). In line with work undertaken within UNESCO since Salamanca, the United Nations Convention on the Rights of Persons with Disabilities (UNCRPD) in 2006, emphasised the right of children and young people with disabilities to an inclusive education alongside their typically developed peers (United Nations, 2006). The UNESCO work has continued, in particular emphasising the need for policy initiatives regarding improving inclusive education and learning opportunities for all children and young people (UNESCO, 2005, 2008, 2009).

In line with the Salamanca Statement and UNCRPD, the aspiration of the inclusion of children with disabilities in regular early childhood/kindergarten education can be seen in several government policies and acts. For instance, in the United States, the Division for Early Childhood (DEC) and the National Association for the Education of Young Children (NAEYC) formulated a joint statement (DEC/NAEYC, 2009) indicating that early childhood/kindergarten inclusive education entails “the values, policies and practices that support the right of every infant and young child and his or her family, regardless of ability, to participate in a broad range of activities and contexts as full members of families, communities and society” (p. 2). In Australia, following the lead of the DEC and NAEYC in the United States, a joint position statement was developed by Early Childhood Australia (ECA) and Early Childhood Intervention Australia (ECIA), which indicated the right of children with disabilities to be placed in ECEC settings (ECA/ECIA, 2012). This has been acknowledged as the foundation for inclusion in ECEC in Australia (Brown & Guralnick, 2012). Furthermore, in the United Kingdom, policy development for early childhood/kindergarten inclusive education has recently been substantially revised with a new Children and Families Act (2014), which emphasises equal and full participation for children and young people with disabilities in early childhood education settings and places their families in the centre of their children’s education by choosing their education placement (Blackburn, 2016).

Most notably, recent work by UNESCO is coordinating the international community to achieve the sustainable development goals of the 2030 agenda set by the United Nations General Assembly in 2015. Sustainable Development Goal 4 captures the right of children with disabilities to inclusive and quality education: “Ensure inclusive and equitable quality education and promote lifelong learning opportunities for all,” in addition to the specific Goal 4.5, which is to “by 2030, eliminate gender disparities in education and

ensure equal access to all levels of education and vocational training for the vulnerable, including persons with disabilities, indigenous peoples and children in vulnerable situations” (Slee, 2018; United Nations Development Programme, 2020).

This section described the kindergarten inclusive education movement internationally. The next section will specifically focus on the inclusive kindergarten education movement in Saudi Arabia, the context of the current study.

2.6 Inclusive Kindergarten Education in Saudi Arabia: History and Current

Policies

Before 1958, individuals with disabilities had no special education support in Saudi Arabia. It was thus the responsibility of the parents to provide any and all assistance to their children with disabilities (Al-Mousa, 1999). However, 1958 was a landmark year as this was when special education services for learners with disabilities were launched (Ministry of Education, 2015). The Ministry of Education began offering evening classes exclusively for learners with visual impairments. In 1960, there was an important advance in the government’s support for special education in Saudi Arabia with the opening of the first school for learners with disabilities, the Noor Institute, in the capital city Riyadh under the auspices of the Ministry of Education. The Noor Institute catered exclusively for learners who were blind. These students were thus the first beneficiaries of government-sponsored special education in Saudi Arabia (Al-Mousa, 1999; Ministry of Education, 2015).

The Ministry of Education established the Department of Special Education in 1962 to administer the provision of special education for children living with deafness, blindness, and intellectual disabilities (Al-Mousa, 1999; Ministry of Education, 2015). In 1972, three institutes were established—in Anaeza, Mecca, and Alhofouf—to provide education for students with deafness, blindness, and intellectual disabilities (Al-Mousa, 1999; Ministry of

Education, 2015). By 1984, the widening provision of special education in Saudi Arabia was evidenced by the availability of an increasing number of facilities and programs supporting special education (Ministry of Education, 2015). In 1987, Saudi Arabia established the first legislation for individuals with disabilities, the Legislation of Disability Act. This legislation stressed the importance of the inclusion of children with disabilities with typically developing peers in the regular educational system. Notwithstanding this, the actual inclusion of children with disabilities in regular kindergarten education programs only began in 1990 (Al-Mousa, 2010) in Riyadh, in the King Saud University Kindergarten (Al-Mousa et al., 2008; Khashrami, 2010). Thereafter, a few private and public kindergartens across the country also began including children with disabilities with their peers in the regular classrooms.

Following the ratification of the United Nations Convention on the Rights of Persons with Disabilities (UNCRPD) in 2008, Saudi Arabia joined this global initiative to foster fair and active participation for all children with disabilities. The number of inclusive kindergartens across Saudi Arabia subsequently increased to 118 in 2017–2018, with 721 children with disabilities enrolled (Ministry of Education, 2019b). As at 2017–2018, Riyadh, where the current study was conducted, had the highest number of inclusive kindergartens with 46 public inclusive kindergartens and a total enrolment of 393 children with disabilities, as well as four private inclusive kindergartens with 16 children with disabilities (Ministry of Education, 2019c).

According to the Ministry of Education's (2019d) current policy document, inclusive kindergarten education refers to the education of all children, including children with disabilities, in regular kindergarten classrooms together with the appropriate support services. This means that children with disabilities are placed alongside their peers without

disabilities in all curriculum activities within a regular kindergarten program schedule and with an effective team of general and special education teachers who will work together in all aspects of planning, teaching and assessment. (Ministry of Education, 2019d). The previous research in Saudi primary and high school settings indicated that the implementation of inclusion in Saudi primary and high schools takes two forms: partial and full inclusion (Al-Mousa et al., 2008; 2008; Al-Mousa, 2010). The partial inclusion refers to including primary and high school students with disabilities in a special classroom in regular schools. This means that students with disabilities learn in special classrooms with their special education teachers, although some students with disabilities included with their peers without disabilities in curricular activities such as physical and art education and in non-curricular activities, such as break times and school trips (Al-Mousa et al., 2008; 2008; Al-Mousa, 2010). Partial inclusion is implemented for primary and high schools students with hearing disabilities, visual disabilities, Autism and multiple disabilities (Alhammad, 2017; Al-Mousa et al., 2008; Al-Mousa, 2010). On the other hand, full inclusion refers to including primary and high school students with disabilities in the regular classroom alongside their peers without disabilities for most of the school day with provision of special educational services such as a resource room and special education teachers. The students with disabilities can be withdrawn from regular classrooms to the resource room with special education teacher when necessary; for example, if the learning needs of students with disabilities cannot be met by general education teachers in the regular classroom and need more support (Alhammad, 2017; Al-Mousa et al., 2008; Al-Mousa, 2010). Full inclusion is implemented for students with learning disabilities, low vision, physical disabilities, emotional and behavioural disorders, and speech and language disorders (Alhammad, 2017; Al-Mousa et al., 2008; Al-Mousa, 2010).

The Ministry of Education's practical guide for Saudi inclusive kindergarten education includes the following procedures:

- A collaborative team consisting of the kindergarten Principal, Principal's assistant, general education teacher, special education teacher and the parents of the children with disabilities must be formed to develop individualised learning goals that achieve agreed and measurable outcomes.
- In cooperation with special education teachers, general education teachers must include all children with and without disabilities in curriculum activities.
- In cooperation with special education teachers, general education teachers must implement practical and advanced strategies to develop all children's capacities.
- General education teachers must follow up on the social and psychological status of all children without disabilities and, in cooperation with the special education teacher, of all children with disabilities.
- Special education teachers must prepare individual educational plans for each child with a disability.
- Special education teachers must implement the goals of the individual educational plans using appropriate adaptive learning resources.
- Special education teachers must provide copies of the individual educational plans to the general education teachers to work on to achieve the goals of such plans through curriculum activities.
- Special education teachers must monitor and report on the progress in achieving the goals of the individual educational plans and address the areas for improvement as needed.
- The kindergarten Principal's assistant must review the monthly progress reports of all the children regardless of their disability status.

- Kindergarten Principals must approve the monthly progress reports of all the children.
- Special aides/teachers' assistants (who hold a post-school qualification or above and have experience working with children with disabilities) must work collaboratively with the general and special education teachers in classrooms to support the children with disabilities in their learning and engagement.
- Special aides/teachers' assistants must contribute by organising and implementing collective cognitive, social, and communication activities.
- Special aides/teachers' assistants must supervise the arriving and picking up routines of children with disabilities in kindergarten (Ministry of Education, 2018b, 2019d).

Because there is a lack of Saudi Arabian research in this area, the extent to which the inclusive policies and practical guidance set out above are implemented in practice is unknown. Thus, there is a need for further research on how inclusive education policy is applied within Saudi kindergarten settings.

In line with the Saudi Vision 2030, the Ministry of Education recently began collaborating with the King Abdullah bin Abdulaziz Education Development Project (*Tatweer*), a comprehensive educational development program aimed at developing kindergartens and opening new kindergartens. *Tatweer* is an Arabic term that means “development,” so in its application, the program aims to improve the Saudi education system by reforming the system and curricula of kindergartens and schools, developing inclusive education services, integrating technology into the curriculum, and requalifying teachers (Tatweer Co for Educational Services, 2020). The key aim of this collaboration is to provide more equal, inclusive education and support services for all children regardless of their gender, abilities, and social and financial backgrounds. The *Tatweer* program is

responsible for providing inclusive supports, such as educational supplies, special aides, procedural guidance on implementing inclusive education in regular kindergarten and school settings, and professional development in inclusive education for general and special education teachers and administrative staff. Tatweer is also collaborating with the College of Education (COE) at the University of Oregon (UO) in the United States to fulfil its objectives. The COE at the UO will provide operational manuals to assist Tatweer in setting up pilot projects developed for inclusive kindergartens and schools, make technical support and ongoing training available (this will take place at the UO and in Saudi Arabia), and evaluate the effectiveness of the pilot projects (UO, n.d.). This movement towards more developed inclusive education in kindergarten settings in Saudi Arabia is timely with respect to the current study, as this study's findings may provide evidence that could be used to assist the movement. This is particularly important given the limited research in the area of inclusive kindergarten education in Saudi Arabia.

2.7 Summary

This chapter provided contextual information regarding kindergarten education in Saudi Arabia; the prevalence of children with disabilities; and the history of, and current policies on, the kindergarten education system in Saudi Arabia. It also reviewed the history of, and current policies on, inclusive kindergarten education internationally and nationally.

As previously emphasised, there is limited research in the area of inclusive education in kindergarten settings in Saudi Arabia. This chapter therefore provided contextual background information on inclusive kindergarten education in Saudi Arabia. It also showed that despite all of the inclusive kindergarten education policies developed by the Ministry of Education in Saudi Arabia, there is a lack of research confirming the extent to which these policies are being implemented in practice. As such, it will contribute to the literature

nationally and internationally and to the development of knowledge on inclusive kindergarten education in Saudi Arabia.

Chapter 3: Teachers' Self-Efficacy and Attitudes Towards Inclusive Education: A Literature Review of Theory, Measurement, and Empirical Research

3.1 Introduction

This chapter reviews, critiques, and synthesises the relevant literature in five sections. The first section introduces the theories that help explain how the constructs of teachers' self-efficacy, their attitudes towards inclusive education, the factors influencing their self-efficacy and attitudes, and the barriers to inclusive education will be conceptualised as terms of reference for this study. In the second section, international and Saudi literature on kindergarten teachers' self-efficacy in inclusive education and its measurement are also reviewed, critiqued, and synthesised. The third section applies the same process to international and Saudi literature on kindergarten teachers' attitudes towards inclusive education and its measurement. The fourth section critically reviews and amalgamates the international and Saudi literature on the teacher-, child-, and context-related factors that influence kindergarten teachers' self-efficacy and attitudes towards inclusive education. Lastly, the final section critically examines and synthesises the international and Saudi literature on kindergarten teachers' perceptions of barriers to inclusive education.

3.2 Theoretical Frameworks

Self-efficacy and attitudes are vital concepts in understanding the thought processes of teachers and their approach to teaching and learning practices in inclusive educational settings. Albert Bandura introduced the concept of self-efficacy as part of his social

cognitive theory in 1977. Bandura defined self-efficacy as the belief of an individual in his or her ability to perform the actions necessary to complete a particular task successfully (Bandura, 1977). The theory postulates that the individual's self-efficacy drives their behaviour and has a direct impact on their choice of activity and on the amount of effort and persistence that they show when confronting problems (Bandura, 1986). Individuals who have high self-efficacy tend to deal with challenging tasks with calmness; conversely, individuals with low self-efficacy tend to perceive challenging tasks as more difficult than they are and also tend to avoid them (Bandura, 1994). Thus, the self-efficacy of an individual can reveal the beliefs and attitudes behind their behaviour.

According to the research literature, in order to teach effectively in inclusive classrooms, teachers need to have three main areas of skills. "These include having knowledge of content and pedagogy (e.g., knowing students' characteristics, selecting instructional goals, adapting instruction to meet individual needs, using co-operative learning), managing classroom environment and behaviour (e.g., designing the classroom environment so as to prevent behaviour problems), and the ability to work collaboratively with parents and paraprofessionals" (Sharma et al., 2012, p. 3). Thus, it could be expected that kindergarten teachers with high self-efficacy in their use of inclusive educational instructions, their management of the behaviour of children with disabilities, and their collaboration with other teachers, staff, and parents will be more willing to include children with disabilities in their regular classrooms and will develop positive attitudes towards inclusive education. On the other hand, teachers with low self-efficacy will view the same actions and processes as demanding and difficult and may, as a result, develop a negative attitude towards inclusive education. The literature further supports this, determining that high self-efficacy in teachers increases the likelihood of their implementing inclusive education and correlates positively with their attitudes towards children with disabilities and

inclusive education (Emam & Mohamed, 2011; Savolainen et al., 2012; Weisel & Dror, 2006; Yada et al., 2018); conversely, studies have found that low self-efficacy in teachers results in their rejection of inclusive education and their lower acceptance of children with disabilities into regular classrooms (Lee et al., 2014). Thus, self-efficacy has an impact on teacher practices in inclusive settings and is therefore an important factor worthy of attention in further research examining the effectiveness of inclusive education.

Another theory that helps provide a suitable theoretical basis to understand the influences and formation of teachers' self-efficacy and attitudes is the theory of planned behaviour (Ajzen, 1991) which was advanced from the theory of reasoned action. This theory states that the positivity of an individual's self-efficacy and attitude towards a particular type of behaviour is directly proportional to the individual's intention of exhibiting that behaviour (Ajzen, 1991). The theory postulates that intentions to perform that particular behaviour are shaped by three important determinants: attitudes towards the behaviour, subjective norm, and perceived behaviour control (self-efficacy) (Ajzen, 2005). In the inclusive classroom, this implies that teachers with positive attitudes towards the inclusion of children with disabilities (attitude towards the behaviour) and high self-efficacy (perceived behavioural control) will demonstrate more inclusionary behaviours, which will, in turn, support the learning environment for these children. On the other hand, teachers with low self-efficacy and negative attitudes towards the inclusion of such children will likely exhibit negative inclusionary behaviours, which may exclude, discriminate against, isolate, and devalue these children. The theory of planned behaviour acknowledges the significance of the influence of background factors on individuals' self-efficacy and attitude towards performing the behaviour of interest. This theory suggests that background factors, such as gender, age, education, ethnicity, and past experience are influential in shaping self-

efficacy beliefs and attitudes towards a certain behaviour; thus, these background factors should be taken into consideration (Fishbein & Ajzen, 2010).

Another useful theory for this study is ecological systems theory, which was developed by Bronfenbrenner in 1979. The theory helps explain the influence of contextual factors and barriers to inclusive education which are represented in different types of environmental systems and how they are responsible for shaping and influencing the self-efficacy and attitudes of kindergarten teachers. The theory entails placing the teacher at the centre of the model and considering how five different environmental systems, also known as levels, influence their self-efficacy and attitude towards inclusive education to varying degrees. These levels interact with each other and are subject to change over time (see Figure 3.1). The first level in this model is the microsystem, which describes an individual's immediate surroundings. There are bidirectional relationships between multiple microsystems (e.g., classroom, children with disabilities, other teachers, principal, and support staff) and the teachers in an inclusive kindergarten classroom; in other words, individuals' reactions to other individuals on the microsystem level will influence how they feel about themselves and in turn how they treat each other. The next level is the mesosystem, which refers to interactions and influences that occur across the different members of a teacher's microsystems, and which have an indirect impact on the teacher's role in inclusive settings. For instance, the relationship between the kindergarten and children's parents and therapists is part of the mesosystem, as it can affect teachers' self-efficacy, attitudes, and behaviour toward inclusive education. The next level described by Bronfenbrenner is the exosystem, which describes settings that do not directly involve any members of the microsystem level but still affect them. These may include regulations that have been determined by policymakers who have not personally interacted with or entered inclusive preschool classrooms. The macrosystem is the next level, comprising societal and

cultural values that influence the other systems. The final level is the chronosystem, which describes the changes in all variables of the systems across time (Bronfenbrenner, 2009). Research demonstrates that, over time, teachers' self-efficacy and attitudes towards inclusive education have changed, and this will continue into the future (Odom et al., 2004). Thus, Bronfenbrenner's theory proposes that the teacher in an inclusive classroom is part of a wider system. The theory also holds that there is a bidirectional relationship between the different environmental systems and teachers' self-efficacy and attitudes towards inclusive education.

Figure 3.1

Application of Bronfenbrenner's Ecological Systems Theory

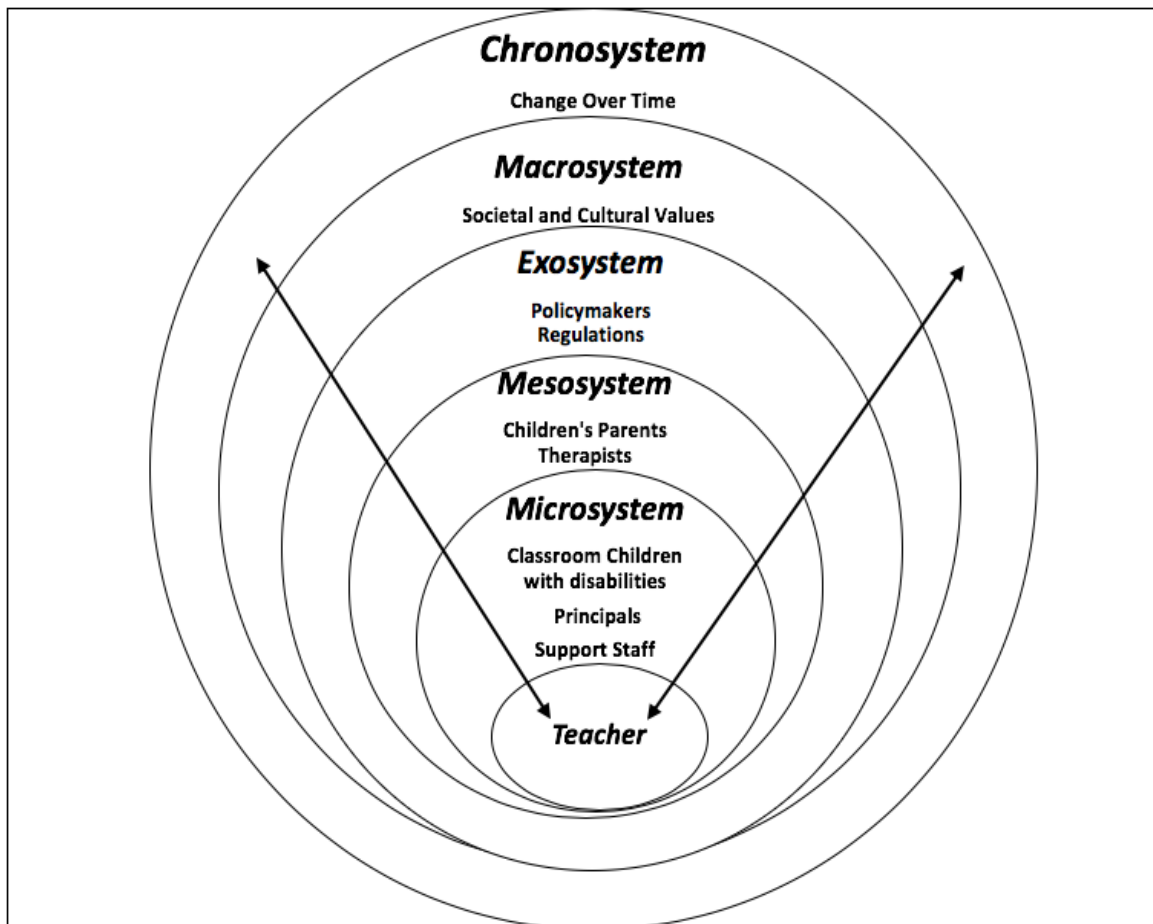

3.3 Teachers' Self-Efficacy in Inclusive Education

As noted above, self-efficacy is a cognitive state first introduced by Bandura (1977) 40 years ago. It refers to an individual's belief in his or her ability to perform the necessary behaviours to complete a particular task successfully (Bandura,1986). In the case of teachers, self-efficacy refers to their feeling of self-confidence in using effective instructional strategies, managing students' behaviours, and persevering in the face of challenges (Guskey & Passaro, 1994).

In recent years, there has been a growing body of international research on teachers' self-efficacy in inclusive practices. This interest is due to the important role of teachers' self-efficacy in the implementation of successful inclusive classrooms. According to Loreman et al. (2013), in order to effectively implement an inclusive approach, teachers must have self-confidence in their own abilities, knowledge, and skills related to inclusive education. To date, however, only a few existing studies worldwide have examined kindergarten teachers' self-efficacy in inclusive education, and no study has focused on the Saudi kindergarten setting. Existing international studies have demonstrated that kindergarten teachers generally show high self-efficacy in inclusive practices, which, in turn, positively influences their implementation of inclusive education (Emam & Mohamed, 2011; Özokcu, 2018a; Sari et al., 2009).

Emam and Mohamed (2011) surveyed 71 kindergarten and 59 primary teachers in Egypt to investigate their self-efficacy in inclusive education. They found that teachers had high levels of self-efficacy in inclusive education on the Teacher Self-Efficacy Scale (Tschannen-Moran & Woolfolk Hoy, 2001). In a quantitative study from Turkey, the self-efficacy in inclusive education of 264 kindergarten teachers was investigated by Sari et

al. (2009) using the Teacher Self-Efficacy Perception Scale (Sari et al., 2009). Their results revealed that the teachers considered themselves efficient in terms of guidance, teaching, and classroom management in the inclusive kindergarten setting. Similarly, another quantitative study conducted in Turkey by Özokcu (2018a) examined the self-efficacy levels in inclusive education of 318 kindergarten teachers using the Teacher Efficacy for Inclusive Practices (TEIP) scale (Sharma et al., 2012). His findings indicated that kindergarten teachers' self-efficacy was generally quite high. Furthermore, their self-efficacy in managing children's behaviour in inclusive classrooms and in using inclusive instructions was higher than their self-efficacy in collaborating with parents and other teachers.

In Saudi Arabia, there is a lack of research on teachers' self-efficacy regarding inclusive education. To the best of the researcher's knowledge, only two studies have examined teachers' self-efficacy, and neither of these examined kindergarten teachers (Alamri, 2014; Alnahdi, 2019a). The mixed-methods study conducted by Alamri (2014) examined 202 primary teachers' self-efficacy in teaching students who had behaviours related to attention deficit/hyperactivity disorder (AD/HD) in regular classrooms. They demonstrated that teachers exhibited high self-efficacy in teaching such students, measured by the Teacher Efficacy Beliefs Scale (Brownell & Pajares, 1999) and supported by findings from semi-structured interviews. Another quantitative study, by Alnahdi (2019), examined 185 in-service teachers' self-efficacy in inclusive classrooms on the TEIP scale (Sharma et al., 2012). The author found that teachers generally had high levels of confidence in their abilities to use inclusive instruction. However, they were less confident in their other abilities, such as managing students' behaviours and involving parents in school activities. The study indicated that positive self-efficacy is an indicator that teachers can work with students with disabilities in inclusive classrooms, which is a critical factor in implementing successful inclusive education. Hence, teachers' self-efficacy should be considered when

examining how inclusive education is implemented in Saudi kindergarten settings. This is because no studies have examined teachers' self-efficacy in terms of including children with disabilities in inclusive kindergarten settings in Saudi Arabia.

3.3.1 Measuring Teacher Self-Efficacy in Inclusive Education

In recent years, a number of studies internationally have assessed teachers' self-efficacy in inclusive practices. Most of these studies were quantitative (Alamri, 2014; Alnahdi, 2019a; Emam & Mohamed, 2011; Özokcu, 2018a; Sari et al., 2009), and some utilised quantitative questionnaires such as the Teacher Efficacy Beliefs Scale (Brownell & Pajares, 1999) and the Teacher Self-Efficacy Scale (Tschannen-Moran & Woolfolk Hoy, 2001).

The Teacher Efficacy Beliefs Scale, developed by Brownell and Pajares (1999), consists of 11 items that measure teachers' efficacy beliefs in instructing and managing students with learning and behavioural difficulties. This scale, however, is very specific and only focuses on teachers' efficacy beliefs in their ability to teach and manage students with specific types of disabilities, such as learning and behavioural difficulties. The Teacher Self-Efficacy Scale, designed by Tschannen-Moran and Woolfolk Hoy (2001), uses a total of 24 items with six dimensions measured by four items each. These six dimensions are instruction, adapting education to individual students' needs, motivating students, keeping discipline, cooperating with colleagues and parents, and coping with changes and challenges.

Whilst both these measures have been shown to have acceptable reliability and validity, they do not specifically conceptualise the context of inclusive practice (Sharma et al., 2012). Some scholars have suggested that teacher self-efficacy is best conceptualised and measured by focusing on a specific context (Bandura, 1997; Chan, 2008). Accordingly,

Sharma et al. (2012) considered inclusive education as a context-specific construct and developed the TEIP scale to measure teachers' self-efficacy in teaching within the inclusive classroom setting. This scale has 18 items, which are divided into six items each under three factors: Efficacy to use inclusive instructions (EII), Efficacy in collaboration (EC), and Efficacy in managing behaviour (EMB). This measure, which has been shown to have good reliability and validity, has been widely used (Alnahdi, 2019). However, the previous validations and applications of the TEIP scale were mostly conducted with elementary, secondary, and pre-service teachers in and across different countries (Alnahdi, 2019C; Loreman et al., 2013; Sharma et al., 2012; Yada et al., 2018). Thus far, only a few studies have focused on kindergarten teachers (Özokcu, 2018a, 2018b), and none have been conducted in the specific context of Saudi kindergartens. Thus, further research using the TEIP scale to measure Saudi kindergarten teachers' self-efficacy in inclusive education is needed. This is because the TEIP scale has the most appropriate level of specificity in measuring teachers' self-efficacy in inclusive education practices—one that focuses strongly on teaching practices and holistically addresses the context of inclusive education.

3.4 Teachers' Attitudes Towards Inclusive Education

Teachers' attitudes have been described as the most important of the many factors that determine the success of inclusive education (Avramidis & Norwich, 2002; Dymond et al., 2008; Hsieh et al., 2012; Yada et al., 2018). Attitudes refer to “a latent disposition or tendency to respond with some degree of favourableness or unfavourableness to a psychological object” (Fishbein & Ajzen, 2010, p. 76). Overall, the positivity of an individual's attitude towards a particular type of behaviour is directly proportional to his or her intention of exhibiting that behaviour (Ajzen, 1991). Such an effect of attitude on behaviour also applies to the inclusion of children with disabilities in regular classrooms. The importance of teachers' attitudes regarding inclusion is based on their potential influence on the deployment of inclusive education strategies for children with disabilities.

A growing body of research worldwide has examined teachers' attitudes towards inclusive education in kindergarten settings. Some of these studies have demonstrated that kindergarten teachers held positive attitudes towards inclusive education (Batu et al., 2017; Bryant, 2018; Dias & Cadime, 2016; Hsieh & Hsieh, 2012; Leatherman, 2007; Štemberger & Kiswarday, 2018). A few studies, however, concluded that kindergarten teachers held neither positive nor negative attitudes towards inclusive education (Özokcu, 2018b; Sari et al., 2009).

Batu et al. (2017) examined kindergarten teachers' opinions regarding inclusive education in Turkey. They conducted semi-structured interviews with 45 kindergarten teachers and found that all the teachers had positive attitudes towards inclusive education. Bryant (2018) used a narrative, phenomenological method to explore kindergarten teachers' attitudes towards inclusive education in a public kindergarten in south-eastern Virginia in

the United States. Open-ended interviews were conducted with eight general education teachers, all of whom expressed positive attitudes and a willingness to teach in inclusive environments. Similarly, Leatherman (2007) used a qualitative narrative approach to examine kindergarten teachers' attitudes to their inclusive classrooms in the south-eastern United States. Eight teachers participated in open-ended interviews and revealed their positive attitudes towards inclusive classrooms. They also felt that an inclusive classroom is an optimal place for children with and without disabilities.

A quantitative study by Dias and Cadime (2016) used the Attitudes Towards Inclusive Education Scale (MATIES) developed by Mahat (2008) and surveyed 68 kindergarten teachers in Portugal to measure their attitudes towards inclusive education. Their findings indicated overall positive attitudes towards inclusive education. Another quantitative study by Štemberger and Kiswarday (2018) explored the attitudes of 129 Slovenian kindergarten and 132 primary teachers towards including children with disabilities in regular classrooms, using the MATIES scale. They found that both kindergarten and primary school teachers were in favour of inclusive education. However, additional analyses demonstrated that kindergarten teachers showed more positive attitudes towards inclusive education than primary teachers. As the researchers explained, this:

might be the result of the fact that preschool teachers in Slovenia have more autonomy in adjusting work, goals, methods etc., and a much more comprehensive image of children which enable them to accept diverseness in a different way, whereas primary school teachers are more performance-oriented, aimed at assessing and perceive more partially (in terms of performance in “their” subject) and may overlook children’s strengths and weaknesses. (Štemberger & Kiswarday, 2018, p. 9)

A quantitative study by Hsieh and Hsieh (2012) investigated urban kindergarten teachers' attitudes towards inclusive education using the Urban Preschool Teachers' Perceptions of Inclusion scale they developed for their study. The survey was completed by 130 kindergarten teachers in low-income urban neighbourhoods in the United States. Their findings indicated that teachers, overall, had a moderately positive attitude towards inclusive education. A mixed-methods study from the United Arab Emirates surveyed 30 kindergarten teachers working in private kindergartens in Dubai and conducted semi-structured interviews with 25 teachers to examine their attitudes towards inclusive education. The results from both the survey and interviews showed that all kindergarten teachers held positive attitudes towards inclusive education (Fakih, 2019).

Sari et al. (2009) conducted a quantitative study to assess 264 Turkish kindergarten teachers' attitudes towards inclusive education by using the Opinions Relative to the Integration of Student with Disabilities Scale (ORI) developed by Antonak and Larrivee (1995). Their findings indicated that kindergarten teachers had unclear attitudes towards inclusive education. Similarly, another Turkish study utilised the ORI scale to examine kindergarten teachers' attitudes towards inclusive education, which were found to be neither positive nor negative (Özokcu, 2018b).

It is evident from the international studies mentioned above that most kindergarten teachers generally have positive attitudes towards inclusive education. Compared to the Saudi Arabian literature, research on teachers' attitudes in the Western world is well-established (Alnahdi, 2019b; Al-quraini, 2012). Although there are a number of studies aimed at analysing teachers' attitudes concerning inclusive education in Saudi Arabia, most of these have concentrated on primary and secondary settings; these Saudi Arabian studies also demonstrate that the complex combinations of negative and positive attitudes vary

depending on the specific type of student disability examined by a study (Adhabi, 2018; Alamri, 2014; Alhudaithi, 2015; Al Jaffal, 2019; Alqahtani, 2017; Alquraini, 2011; Alquraini, 2012; Aseery, 2016). In addition, as previously noted, no empirical research has been conducted on teachers' attitudes towards inclusive education in the kindergarten setting in Saudi Arabia.

A quantitative study by Alquraini (2011) utilised the ORI scale and surveyed 400 primary general and special education teachers to examine their attitudes towards the inclusion of students with severe disabilities. The study found that both groups of teachers held slightly negative attitudes towards including such students. Alquraini (2011) also examined the differences between the attitudes of the two groups of teachers and found that general education teachers exhibited more positive attitudes than did special education teachers towards the inclusion of these students. Similarly, Al-quraini (2012) conducted a quantitative study and investigated the attitudes of 303 Saudi general education teachers in primary schools regarding the inclusion of students with severe intellectual disabilities. The attitudes of such teachers were also measured using the ORI scale. The findings indicated that teachers had slightly negative attitudes towards the inclusion of such students in regular classrooms.

In a mixed-methods study, Alamri (2014) examined 202 Saudi primary teachers' attitudes towards including students with AD/HD-related behaviours in regular classrooms by using the Attitude towards Inclusion Scale (TAIS) developed by Soodak et al. (1998) and by conducting semi-structured interviews. The results of both the questionnaires and interviews revealed that Saudi primary teachers held positive attitudes towards including students with AD/HD-related behaviours in regular primary classrooms. Another mixed-methods study by Alhudaithi (2015) explored the attitudes of female primary teachers and

autism special institution teachers towards inclusive education for children with autism spectrum disorder (ASD). The teachers' attitudes were explored using the ORI scale and semi-structured interviews. The findings from the questionnaires and interviews indicated that both groups of teachers had generally positive attitudes towards inclusive education.

Aseery (2016) conducted a quantitative study to examine the attitudes of 196 Saudi general and special education teachers with regard to the inclusion of students who were hard of hearing or deaf in regular classrooms. The participants were employed in regular primary and secondary schools as well as special institutions for the deaf. The author examined the teachers' attitudes by using the ORI scale and found that both groups of teachers held slightly negative attitudes towards the inclusion of such students in regular education classrooms. In other words, his results did not show a significant difference between the attitudes of general and special education teachers. Using the ORI scale, Alqahtani (2017) investigated 262 Saudi general secondary school teachers' attitudes about inclusive education for students with learning disabilities. His findings revealed that Saudi secondary school teachers had positive attitudes regarding the inclusion of students with learning disabilities.

A recent quantitative study by Adhabi (2018) also used the ORI scale and investigated the attitudes of 402 primary general and special education teachers towards including students with ASD in regular classrooms. The study results revealed that teachers generally had negative attitudes towards including such students. Furthermore, there were no significant differences between the attitudes of general and special education teachers. In contrast, Al Jaffal (2019) conducted a quantitative online survey of 2,000 Saudi secondary teachers to examine their attitudes towards including students with ASD in their classrooms. The teachers' attitudes were measured by the Attitudes toward Inclusion of

Student with Autism Scale (ATISAS), which was developed by Haimour and Obaidat (2013). The findings showed that Saudi secondary school teachers held positive attitudes towards the inclusion of students with ASD.

In all the research mentioned above, Saudi teachers' attitudes towards including students with a specific type of disability were only assessed in primary and high school settings. These studies showed a combination of negative and positive attitudes depending on the specific type of student disability. However, no empirical research has been conducted on Saudi teachers' attitudes towards inclusive education in the Saudi kindergarten setting or on their attitudes towards the inclusion of children with all types of disabilities. Therefore, further research is needed to understand teachers' attitudes towards inclusive education for children with all types of disabilities in the kindergarten setting. This is especially important given the significance of education in the early years and the important influence of teachers' attitudes on implementing successful inclusive education.

3.4.1 Measuring Teachers' Attitudes Towards Inclusive Education

Of the studies that have been conducted on teachers' attitudes towards inclusive education, most have used a single qualitative or quantitative approach. For example, a number of studies used qualitative, narrative, open-ended interviews or semi-structured interviews (e.g., Batu et al., 2017; Bryant, 2018; Leatherman, 2007). Many other studies have used quantitative scales (e.g., Adhabi, 2018; Al Jaffal, 2019; Alqahtani, 2017; Alquraini, 2011; Al-quraini, 2012; Aseery, 2016; Dias & Cadime, 2016; Hsieh & Hsieh, 2012; Özokcu, 2018b; Sari et al., 2009; Štemberger & Kiswarday, 2018). However, only a few have used mixed methods to measure teachers' attitudes (e.g., Alamri, 2014; Alhudaithi, 2015).

Regarding the quantitative scales used in previous research, many scales have been developed to measure teachers' attitudes towards inclusive education. However, the psychometric properties of these instruments have often been unexplored or weak. One example is the Urban Preschool Teachers' Perceptions of Inclusion scale, which was developed by Hsieh and Hsieh (2012). This scale consists of 19 items that aim to capture teachers' "core beliefs and perceptions of benefits for children, responsibility for children with disabilities, and perceptions of influences on quality of teaching" (Hsieh & Hsieh, 2012, p. 1173). Although this scale showed good internal consistency reliability, no tests of construct validity were reported (Hsieh & Hsieh, 2012). Moreover, this scale has not been widely used to measure teachers' attitudes towards inclusive education. Another scale that has been used to examine teachers' attitudes is the Attitudes Towards Inclusive Education Scale (MATIES), designed by Mahat (2008). This scale consists of 18 items divided into three factors (six for each factor): the affective factor, cognitive factor, and behavioural factor. The MATIES demonstrated good internal consistency reliability and acceptable validity. It has also been widely utilised in many studies (Ewing et al., 2018).

The Attitude towards Inclusion Scale (TAIS), developed by Soodak et al. (1998), consists of a hypothetical scenario in which a principal informs participants that a student with a disability would be included in their regular classes. Each participant was assigned just one of the different disability categories, which included hearing disability, learning disability, intellectual disability, physical disability, and behavioural disorders. Participants then responded to a set of 17 pairs of adjectives on a 4-point Likert-type scale (Soodak et al., 1998). This scale was reported to have acceptable internal consistency reliability; however, the construct validity was not reported (Ewing et al., 2018).

The Opinions Relative to the Integration of Students with Disabilities (ORI) scale was modified by Antonak and Larrivee (1995) from the Opinions Relative to Mainstreaming (ORM) scale originally developed by Larrivee and Cook (1979). The ORI is a 25-item scale that is categorised into four different factors: (1) benefits of integration, (2) integrated classroom management, (3) perceived ability to teach students with disabilities, and (4) special versus integrated general education teachers. The ORI has demonstrated good reliability and construct validity (Antonak & Larrivee, 1995; Ewing et al., 2018). This scale has also been widely used to measure teachers' attitudes towards inclusive education. In addition, the ORI scale has been successfully translated into the Arabic language and consequently validated and used for measuring Saudi primary and high school teachers' attitudes towards inclusive education (Adhabi, 2018; Alhudaithi, 2015; Alqahtani, 2017; Alquraini, 2011; Aseery, 2016). However, the ORI scale has not been translated and used to measure Saudi kindergarten teachers' attitudes towards inclusive education. The reason behind the previous use of the ORI scale to measure Saudi teachers' attitudes in primary and secondary school settings is that it has comprehensive factors that are appropriate for obtaining information on the attitudes of both special and general education teachers. However, the ORI scale's appropriateness has yet to be assessed in the context of Saudi kindergarten teachers. Thus, more research should use and validate this scale in such a setting.

3.5 Factors Influencing Teachers' Self-Efficacy and Attitudes Towards

Inclusive Education

To date, no studies have examined Saudi kindergarten teachers' self-efficacy and attitudes towards inclusive education, and thus this study draws inferences from international research to determine the extent to which these are influenced by teacher-

related, child-related, and context-related factors. Teacher-related factors include teachers' age, teaching position, teaching experience, training, and having a family member or close relative or friend with a disability. Child-related factors include the type of disabilities and their severity. Context-related factors include physical and personnel support. The influencing factors were divided as teacher-, child-, and context-related factors in light of the suggestions of the theory of planned behaviour (Ajzen, 1991) and ecological systems theory (Bronfenbrenner, 1979). The theory of planned behaviour suggests that factors, such as gender, age, education, ethnicity, and past experience are influential in shaping self-efficacy beliefs and attitudes towards a certain behaviour; thus, these background factors are taken into consideration and named as teacher-related factor. However, the ecological systems theory helps explain the influence of child and context related factors on teachers' self-efficacy and attitudes (as explained in section 3.2).

The following discussion considers how teacher-, child-, and context-related factors may be influential in shaping teachers' self-efficacy and attitudes towards inclusive education, drawing on research with primary and secondary teachers and in settings outside of Saudi Arabia given the paucity of research with Saudi kindergarten teachers.

3.5.1 Teacher-Related Factors: Teachers' Age

Few existing international studies have yielded consistent results regarding the relationship between teachers' age and their self-efficacy in inclusive education. For instance, quantitative studies in Turkey and South Korea have examined the relationship between teachers' age and their level of self-efficacy in inclusive education and found no significant relationship (Özokcu, 2018a; You et al., 2019).

In terms of the relationship or influence of teachers' age on their attitudes towards inclusive education, a number of international studies have demonstrated inconsistent

results. Two quantitative studies conducted in South Korea by You et al. (2019) and in India by Parasuram (2006) found that kindergarten teachers' age had no influence on or relationship with their attitudes towards inclusive education. In contrast, Avramidis and Norwich (2002) reviewed several studies on the attitudes of teachers towards inclusive education and reported that younger teachers tended to have a more positive attitude towards the inclusion of children with disabilities.

The relationship between teachers' age and their level of self-efficacy in inclusive education has not been studied in the context of Saudi Arabia. However, regarding the association between Saudi teachers' age and teachers' attitudes, a number of studies in primary and high school settings have yielded inconsistent findings. A mixed-method study on the attitudes of Saudi primary teachers regarding the inclusion of students with AD/HD-related behaviours in regular classrooms found no relationship between the age of teachers and their attitudes (Alamri, 2014). A quantitative study by Al-Ahmadi (2009) found no relationship between the age of teachers and their overall attitude to the inclusion of students with learning disabilities. Another quantitative study, by Alqahtani (2017), investigated Saudi high school teachers' perceptions about inclusive education for students with learning disabilities and showed that older teachers tended to have more positive attitudes towards the inclusion of such students.

Thus, the lack of research on teachers' age and self-efficacy and the inconsistent results related to age and attitudes of primary and high school teachers reveal a need for further research on the influence of Saudi teachers' age on their self-efficacy and attitude towards inclusive education to help clarify these relationships; this is particularly required in kindergarten settings, as there is an absence of such research in these settings.

3.5.2 Teacher-Related Factors: Teachers' Teaching Position

Teachers' teaching position, whether primarily as general education teachers or special education teachers, may influence their level of self-efficacy and attitude towards inclusive education. In terms of teaching position and teachers' self-efficacy, the influence of teaching position on kindergarten teachers' self-efficacy or on the differences in levels of self-efficacy between special and general education teachers in inclusive education has not been investigated in previous international studies, including in Saudi Arabia. However, one study set in primary and secondary school settings by Wang et al. (2012) found that Chinese primary and secondary special education teachers had higher self-efficacy in inclusive education than general education teachers.

In regard to teaching position and teachers' attitudes, a quantitative international study by Hussain (2017) surveyed kindergarten special and general education teachers in the United Arab Emirates to investigate the influence of educational specialty and culture on the attitudes of teachers toward inclusive education. No differences were found between the attitudes of kindergarten special and general education teachers towards inclusive education, and they demonstrated similarly positive attitudes.

In Saudi Arabia, while no studies have yet examined the influence of teaching position on teachers' self-efficacy, a number of studies have investigated the influence of teaching position on the attitudes of primary teachers towards inclusive education. For instance, a quantitative study investigated the attitudes of primary general and special education teachers towards including students with ASD in regular classrooms. The study revealed no significant influence of teaching position on teachers' attitudes (Adhabi, 2018). Similarly, in a quantitative study exploring the attitudes of primary teachers with regard to including students who were deaf or hard of hearing in regular classrooms, Alasim

and Paul (2019) found no significant influence of teaching position on teachers' attitudes. Other research studies, however, have found a strong association between teachers' teaching position and their attitude towards inclusive education. For example, Alquraini (2011) conducted a quantitative study to examine primary teachers' attitudes towards the inclusion of students with severe disabilities. The study found that special education teachers exhibited more positive attitudes than did general education teachers towards the inclusion of these students. This finding was consistent with the results of a quantitative study by Alqahtani (2017), who investigated Saudi high school teachers' attitudes about inclusive education for students with learning disabilities. His study revealed that special education teachers had more positive attitudes towards inclusive education than general education teachers. A mixed-methods study by Alhudaithi (2015) explored the attitudes of female primary and autism special institute teachers towards inclusive education for children with ASD. Her study found that special institute teachers had more positive attitudes towards inclusive education than general education teachers in primary schools. However, all these studies indicated inconsistent results with regard to the influence of teaching position on Saudi teachers' attitudes towards inclusive education. Moreover, there is no research on teaching position and Saudi teachers' self-efficacy in inclusive education for any educational level, including kindergarten. This fact highlights the need for further studies in these areas to fill this research gap.

3.5.3 Teacher-Related Factors: Years of Teaching Experience

Teachers' years of experience with children with disabilities may influence their self-efficacy and attitude towards inclusive education. Only a few international studies have been conducted that consider the influence of teachers' years of experience on their self-efficacy, and these have yielded consistent findings. Quantitative studies from Egypt by Emam and Mohamed (2011) and from Turkey by Özokcu (2018a) found that teachers' years

of teaching experience was one of the primary factors that influenced kindergarten teachers' self-efficacy in inclusive education. Both studies reported that kindergarten teachers with more years of teaching experience had higher self-efficacy in inclusive education than teachers with fewer years of experience.

Regarding the influence of teachers' years of experience on kindergarten teachers' attitudes towards inclusive education, a number of quantitative international studies have revealed inconsistent findings. For example, some studies have found that kindergarten teachers' years of teaching experience was a predictor of their attitudes towards inclusive education, with more experienced kindergarten teachers holding more positive attitudes towards inclusive education than less experienced teachers (in Egypt, Emam and Mohamed, 2011; in South Korea, You et al., 2019). Conversely, Dias and Cadime (2016) in Portugal and Štemberger and Kiswarday (2017) in Slovenia found that teachers' years of teaching experience had no significant effect on their attitude towards inclusive education.

In Saudi Arabia, there is an absence of research on teachers' years of teaching experience and the relationship of this with their self-efficacy levels in inclusive education. However, a number of Saudi studies have examined associations between or the influence of teachers' years of experience on primary teachers' attitudes towards inclusive education. A quantitative study by Adhabi (2018) indicated that Saudi primary teachers' years of experience was a significant predictor of their negative attitudes towards inclusion of students ASD in regular classrooms; and that as their years of teaching experience increase, their attitudes became more negative towards the inclusion of such students. Another quantitative study by Alquraini (2011) demonstrated, conversely, that Saudi primary general and special education teachers with more years of teaching experience had more positive

attitudes towards including students with severe disabilities in regular classrooms than teachers with less experience.

These findings were both inconsistent with a study by Alamri (2014), which reported no correlation between Saudi primary teachers' years of experiences and their attitudes towards inclusion of students with AD/HD-related behaviours in regular classrooms. Alasim and Paul (2019) also found no relationship between the attitudes of primary teachers in terms of including students who were deaf or hard of hearing in regular classrooms and teachers' years of teaching experience. Another study by Aseery (2016) found that teachers' years of teaching experience did not influence their attitudes towards including students who were hard of hearing or deaf in regular classrooms.

It is important to note that the studies reviewed above indicate inconsistent findings, and there is a lack of research on teachers' teaching experience and self-efficacy in inclusive education in Saudi Arabia. Therefore, further research in these areas could fill this gap in the literature, particularly in kindergarten contexts, and provide additional information which might help clarify the relationship between teachers' teaching experience and their self-efficacy and attitudes towards inclusive education.

3.5.4 Teacher-Related Factors: Teachers' Training

Numerous international studies have highlighted the importance of pre-and in-service training for inclusive education and its influence on the self-efficacy and attitudes of kindergarten teachers towards inclusive education. A number of these studies have discovered a positive correlation between teachers' pre- or in-service training and their self-efficacy in inclusive education. These studies have reported that kindergarten teachers with pre- or in-service training on inclusive education had higher self-efficacy than teachers without such training (Özokcu, 2018a; You et al., 2019).

Other studies have noted that the attitudes of kindergarten teachers improved as a result of their training in inclusive education. For instance, Lee et al. (2015) conducted a quantitative study in Hong Kong to examine the predictors of kindergarten teachers' attitudes towards including children with disabilities in regular classrooms. Their findings indicated that kindergarten teachers with in-service training in inclusive education had positive attitudes towards inclusive education (Lee et al., 2014). Correspondingly, a quantitative Slovenian study conducted by Štemberger and Kiswarday (2017) discovered that kindergarten teachers' in-service training in inclusive education led to a more positive attitude towards inclusive education. However, qualitative and mixed-methods studies conducted in Turkey and United Arab Emirates demonstrated that although kindergarten teachers had positive attitudes towards inclusive education, they had insufficient knowledge about working with children with disabilities in inclusive settings due to a lack of pre- and in-service training (Batu et al., 2017; Fakhri, 2019).

A mixed-methods study on the attitudes of primary teachers regarding the inclusion of students with AD/HD-related behaviours in Saudi Arabia revealed that teacher training was a significant predictor of teachers' attitudes and self-efficacy towards the inclusion of such students (Alamri, 2014). In the interview findings of the Alamri study, all teachers decried their lack of training in managing students with AD/HD-related behaviours before and during their service (Alamri, 2014). Conversely, a quantitative study by Aseery (2016) examined the attitudes of general and special education teachers towards including students who were hard of hearing or deaf in regular classrooms. This study found that teachers who had pre-service or in-service training in inclusive education demonstrated more positive attitudes than teachers who had never undertaken training or participated in courses on inclusive education. Adhbi (2018) conducted a quantitative study investigating the attitudes of primary general and special education teachers to the inclusion of students

with ASD in regular classrooms. The results of the study revealed that teachers who had taken at least one course about inclusive education or disabilities had more positive perceptions than teachers who had never taken a course.

On balance, the international and Saudi research shows that teacher training either at a pre-service or in-service level often leads to the formation of more positive self-efficacies and attitudes. However, it is important to note the lack of research in Saudi Arabia on the link between teachers' training and teachers' self-efficacy and attitudes towards inclusive education for children with all types of disabilities in all educational levels, and the absence of such research at the kindergarten level. Therefore, there is a need for further studies in these areas to fill this research gap.

3.5.5 Teacher-Related Factors: Having a Family Member, Close Relative, or Friend

With a Disability

A few research studies have investigated whether or not having a family member, close relative, or friend with a disability might affect kindergarten teachers' self-efficacy and attitudes towards including children with disabilities in regular classrooms. A quantitative study conducted in Turkey by Özokcu (2018a) found that having family members with disabilities, or having social interactions with people with disabilities, had no significant effects on kindergarten teachers' levels of self-efficacy in inclusive education. In contrast, in a mixed-methods study, Ramli (2017) surveyed and interviewed kindergarten teachers to examine their attitudes towards inclusive education in Malaysia. The findings revealed that teachers who had a family member or relative with disabilities had more positive attitudes towards children with disabilities.

In Saudi Arabia, no studies have examined the association between teachers' self-efficacy in inclusive education and having a family member, close relative, or friend with a

disability in any educational level, including kindergarten. However, a number of Saudi studies have examined the association between primary and secondary teachers' attitudes and having a family member, close relative, or friend with a disability, and they have yielded consistent findings. For example, Alasim and Paul (2019), Alquraini (2011), Al-Ahmadi (2009), and Aseery (2016) reported that having family members or relatives with disabilities did not affect primary or secondary teachers' attitudes towards including students with disabilities in regular classrooms.

The lack of international and Saudi studies in all educational levels, including kindergarten, on the relationship between teachers' having a family member, close relative, or friend with a disability and their self-efficacy and attitude towards inclusive education, or the influence of this variable on these outcomes, suggests that further studies are needed to provide additional information that might assist in clarifying such influences or relationships.

3.5.6 Child-Related Factors: Type of Disability and Severity

There has been limited research focusing on the influence of the type and severity of children's disabilities on kindergarten teachers' self-efficacy in inclusive education, or the relationships between these variables. Only a few studies, conducted in primary and secondary settings, have examined the relationship between teachers' self-efficacy and disability type and severity. A quantitative study by Hofman and Kilimo (2014), implemented in primary schools in Tanzania, found no significant relationship between teachers' self-efficacy and the children's type of disability or its severity. Conversely, Yada and Savolainen (2019) discovered positive correlations between teachers' self-efficacy and students perceived as having a moderate disability, and a negative correlation between teachers' self-efficacy and their perception of students having severe disabilities. Regarding

teachers' attitudes, a number of studies have examined the influence of the type and severity of children's disabilities on kindergarten teachers' attitudes. For instance, a qualitative study by Batu et al. (2017) elicited kindergarten teachers' opinions regarding inclusive education in Turkey. Their data revealed that the majority of teachers reported that children with mild and moderate disabilities were the most suitable to include in regular classrooms. A mixed-methods study by Fasih (2019) surveyed and interviewed kindergarten teachers in the United Arab Emirates to determine their attitudes towards inclusive education. The findings demonstrated that most teachers held positive attitudes towards the inclusion of children with hearing and visual impairments, cerebral palsy, and Down Syndrome in regular classrooms, whereas they held negative attitudes towards including children with behavioural disorders, learning difficulties, and communication disorders.

Gezer and Aksoy (2019) also conducted a qualitative study in Turkey in which they interviewed kindergarten teachers to evaluate their attitudes towards including children with disabilities in regular classrooms based on their roles within the inclusive education context. In the interviews, some teachers mentioned that children with severe intellectual disabilities were not suitable for inclusive education, and partial inclusion would be best for these children. Lee et al. (2014) conducted a quantitative study to investigate the attitudes of Hong Kong kindergarten teachers towards including children with disabilities in regular classrooms and whether their attitudes varied depending on the children's disability type. The kindergarten teachers were more accepting of the inclusion of children with speech, language, and learning disabilities than of those with autism, behavioural challenges, or physical disabilities. This is because the teachers perceived speech and learning disabilities as less severe and easier to accommodate than other types of disabilities.

In Saudi Arabia, no studies have investigated the relationship between the type and severity of children's disabilities and teachers' self-efficacy in inclusive education. Most existing studies have, however, focused on the attitudes of primary and high school teachers towards including students with a particular type of disability in regular classrooms. Alquraini (2011) reported that primary teachers were not accepting of including students with severe disabilities. Alamri's (2014) study found that primary teachers generally supported the inclusion of students with AD/HD-related behaviours in mainstream classroom settings. Furthermore, Alqahtani (2017) indicated that high school teachers had positive attitudes to including students with learning disabilities in regular classrooms. Another study by Abed and Alrawajfh (2017) explored primary school teachers' opinions regarding the inclusion of students with different types of disabilities in regular classrooms. Their findings demonstrated that teachers were more accepting of students with mild intellectual and visual disabilities than of students with severe intellectual disabilities and behavioural disorders.

In short, these studies have shown inconsistent results in terms of the relationship between the type and severity of children's disabilities and teachers' attitudes towards inclusive education. Moreover, there is no research on the relationship between the type and severity of children's disabilities and Saudi teachers' self-efficacy in inclusive education for any educational level, including kindergarten. This highlights the need for further studies in these areas to fill this research gap to determine which types of disabilities influence teachers' self-efficacy and attitudes towards inclusive education to inform how best to resource and facilitate the best inclusive teaching practices to benefit all children.

3.5.7 Context-Related Factors: Physical and Personnel Support

Contextual factors can be categorised as physical supports (availability of resources, materials, and equipment; the number of children in the classrooms or class size; classroom time; and education policy support) and personnel support (availability of special aides or teacher assistants; collaboration with other teachers, administrators, and parents). These contextual factors are important for teachers in developing positive self-efficacy and attitudes towards inclusive education. However, there has been surprisingly little research, at any educational level, including kindergarten, on the influence of these contextual factors on teachers' self-efficacy and attitudes towards inclusive education, or the relationship between these contextual factors and such outcomes.

The few existing studies have reinforced that access to physical and personnel support are critical to positively influencing teachers' self-efficacy and attitude towards inclusive education. Hosford and O'Sullivan (2016) surveyed primary teachers in Ireland to examine the relationship between their self-efficacy in inclusive education and the school climate. They found that teachers who felt they had access to school resources had higher self-efficacy in managing students' behaviour in the inclusive classroom and in collaborating and implementing inclusive instruction. Furthermore, the majority of teachers reported that the models of government policy and resource allocation in place were barriers to their self-efficacy in managing inclusive classrooms and students' learning challenges.

Another quantitative study, by Chiner and Cardona (2013), investigated kindergarten, primary, and secondary general teachers' attitudes towards inclusive education and how their attitudes varied depending on the accessibility of resources and support. The findings indicated that teachers who perceived sufficient physical and

personnel support from special aides and therapists were more optimistic and held more positive attitudes towards inclusive education than teachers who did not believe they had sufficient support. In a qualitative study, Fyssa et al. (2014) examined Greek kindergarten teachers' understanding of inclusive education and their attitudes to engaging children with disabilities in inclusive classroom activities. The results of semi-structured interviews revealed that lack of collaboration between teachers prevented them from developing positive attitudes towards inclusive education.

In Saudi Arabia, there is an absence of research on the influence of contextual factors on teachers' self-efficacy in inclusive education across all educational levels. However, a few studies have demonstrated the influence of contextual factors on Saudi teachers' attitudes in primary settings. A study by Alquraini (2011) reported that primary school teachers' negative attitudes towards including children with severe disabilities stemmed from a lack of both physical support, such as relevant equipment and curriculum, and personnel support, including therapists and paraprofessionals. Another study by Alquraini (2012) found that large class sizes were significantly related to the negative attitudes of teachers toward the inclusion of students with severe intellectual disabilities. Alamri's (2014) study also indicated that class size was negatively associated with teachers' attitudes towards including students with AD/HD-related behaviours in regular classrooms: that is, the larger the class size, the less positive the teachers' attitudes towards including such students in regular classrooms.

In sum, there is limited research on the influence of contextual factors on kindergarten teachers' self-efficacy and attitudes towards inclusive education, both in Saudi Arabia and internationally. There is thus a need for further studies in these areas to address this research gap.

3.6 Teachers' Perceptions of Barriers to Inclusive Education

A few existing international studies in kindergarten settings have indicated a range of barriers to inclusive education that are perceived by teachers: namely, a lack of support from Principals and parents, a lack of collaboration between teachers, a lack of funds and physical and personnel resources, poor policy support, and a negative understanding of disabilities. For example, in a qualitative study conducted in the United States, Smith and Smith (2000) revealed that a lack of support from administrators and parents and a lack of collaboration between teachers were barriers that prevented the successful implementation of inclusive education practices in kindergarten settings. Furthermore, Purdue (2009) examined the barriers to inclusive education in kindergarten settings in New Zealand, and the findings indicated that teachers' negative understanding of disabilities and a lack of funds and resources were barriers to the inclusion of some children with disabilities. A quantitative study in Spain found that kindergarten, primary, and secondary teachers perceived the lack of special aides or teaching assistants, large class sizes, and inappropriate physical environments as barriers to inclusive education (Chiner & Cardona, 2013).

Furthermore, a recent qualitative study in Turkey evaluated kindergarten teachers' perceptions of inclusive education based on the teachers' roles within the inclusive education context. Results revealed that the absence of support, inappropriate materials and resources, and large classrooms sizes were the main barriers encountered by teachers in implementing inclusive education in kindergartens (Gezer & Aksoy, 2019). In another qualitative case study, conducted in Hong Kong, Zhu et al. (2019) investigated the practice of inclusive education in a regular kindergarten classroom through observations, interviews, and documentation analysis involving kindergarten teachers. The findings indicated that the

lack of policy support for inclusive practice quality, funding, and curricula were major barriers to inclusive education in kindergartens.

In Saudi Arabia, there is an absence of research on teachers' perception of barriers to inclusive education in kindergarten settings. However, a few studies have indicated teachers' perception of barriers to inclusive education for children with specific types of disabilities in primary or secondary settings. In a qualitative study, Alhammad (2017) explored the barriers perceived by primary school teachers to the implementation of inclusive education for students with learning difficulties in Saudi primary schools. The results showed that the perceived barriers to including such students were the lack of inclusive education training courses, poor communication with the parents of students with learning disabilities, inappropriate curriculum, lack of teaching materials, inappropriate physical environments, lack of Principals' support, and large class sizes. Other quantitative studies conducted in Saudi primary schools have revealed that the lack of special aides or teaching assistants, the lack of support from Principals, inappropriate physical environments (Alquraini, 2011, 2012), a lack of collaboration between teachers, and large classes (Alamri, 2014; Alquraini, 2011, 2012) were barriers to the successful implementation of inclusive education for students with severe disabilities and AD/HD-related behaviours.

As shown above, only a few international studies have examined the barriers to inclusive education in kindergarten settings. In Saudi Arabia, there is no research that has identified the barriers to inclusive education in a kindergarten setting, and only a few studies have been conducted in primary and secondary settings. This situation highlights the need for further studies to explore the barriers to inclusive education in kindergarten settings. More studies are required because implementing robust and holistic inclusive practices remains unlikely unless the barriers are identified and effectively addressed.

3.7 Summary

This chapter has presented several theories: namely, social cognitive theory, the theory of planned behaviour, and ecological systems theory. These theories help explain teachers' self-efficacy and attitudes towards inclusive education, factors influencing their self-efficacy and attitudes, and their perceptions of the barriers to inclusive education. This chapter has also reviewed, critiqued, and synthesised the international and Saudi literature on teachers' self-efficacy and attitudes towards inclusive education and the measurement of these constructs; the teacher-, child-, and context-related factors that influence their self-efficacy and attitudes; and their perceptions of barriers to inclusive education in kindergarten settings.

The literature review revealed a limited number of international studies on kindergarten teachers' self-efficacy and attitudes towards inclusive education and no empirical studies for this particular topic in Saudi kindergarten settings. Concomitantly, there are no empirical studies of the teacher-, child-, and context-related factors that influence teachers' self-efficacy and attitudes and their perceptions of barriers to inclusive education in kindergarten settings in Saudi Arabia. As a result, for Saudi Arabia, research is warranted given the dearth of research in this area.

The literature review also revealed that most of the international and Saudi studies used either quantitative or qualitative methods, with only a few utilising a mixed-methods approach to explore teachers' self-efficacy and attitudes, the factors influencing their self-efficacy and attitudes, and their perceptions of the barriers to inclusive education. A mixed-methods approach enables the development of a more complete and true account of an issue compared to a single method approach (Creswell & Plano Clark, 2018), which

justifies the use of mixed methods in the current study. In the following chapter, the current study's research aims and rationale will be addressed, and the research questions articulated.

Chapter 4. Research Aims, Rationale, and Questions

4.1 Introduction

The purpose of the current chapter is to present: (a) a statement of the problem, which is supported by, and formulated based on, the existing literature; (b) the aims of the study; (c) the rationale behind these aims; (d) the research questions to be addressed; and (e) the significance of the study to stakeholders.

4.2. Statement of the Problem

Teacher self-efficacy and attitude play a vital role in the successful implementation of inclusive education. Therefore, many studies have been conducted in Western countries to assess teacher self-efficacy and attitudes towards inclusive education in kindergartens (e.g., Emam & Mohamed, 2011; Hsieh & Hsieh, 2012; Özokcu, 2018b; You et al., 2019). However, few studies have addressed teacher self-efficacy and attitudes towards inclusive education in Saudi Arabia. In addition, those studies that have been conducted in Saudi Arabia have focused only on inclusion of students with a particular type of disability, or on primary and secondary school settings rather than kindergarten settings (e.g., Al-Ahmadi, 2009; Alamri, 2014; Alhudaithi, 2015; Al-quraini, 2012). To date, Saudi teachers' self-efficacy and attitudes towards the inclusion of all children with disabilities in kindergarten have not been examined.

Without this inquiry into teacher self-efficacy and attitudes, the implementation of effective inclusive education in Saudi kindergartens would be challenging. Thus, this empirical study aims to advance the knowledge of inclusive kindergarten education in Saudi Arabia. The focus is teacher self-efficacy and attitudes towards inclusive education for all

children with disabilities. The influence of teacher-, child-, and context-related factors on teachers' self-efficacy and attitudes, as well as teacher perceptions of the barriers to inclusive education, will also be examined. Given the dearth of empirical research on this issue, effective tools for measuring kindergarten teachers' self-efficacy and attitudes are needed. Thus, this study also aims to use and to verify the validity and reliability of well-established scales to measure Saudi kindergarten teachers' self-efficacy and attitudes towards inclusive education. Given the limited research conducted on inclusive kindergarten education in Saudi Arabia, this study's findings may provide evidence that could be used to assist the Saudi Tatweer program (Tatweer Co for Educational Services, 2020) to achieve its key aim which is to provide to provide more equal, inclusive education and support services for all children regardless of their gender, abilities, and social and financial backgrounds.

4.3. Research Aims, Rationale, and Questions

Based on the above statement of the problem, this study aims to explore kindergarten teachers' self-efficacy and attitudes towards inclusive education in Saudi Arabia. The influence of teacher-, child-, and context-related factors on self-efficacy and attitudes, as well as teacher perceptions of the barriers to inclusive education, will also be examined. These aims will be achieved by using convergent mixed methods, incorporating a quantitative questionnaire and qualitative semi-structured interviews (see Chapter 5).

The four research aims of the study, with associated rationales, are set out in the following subsections.

4.3.1. Research Aim 1

Aim: To assess the validity and reliability of the Teacher Efficacy for Inclusive Practices (TEIP) and Opinions Relative to the Integration of Students with Disabilities

(ORI) scales to measure Saudi kindergarten teachers' self-efficacy and attitudes towards inclusive education.

Rationale: Studies across several countries and languages have used and validated the TEIP scale to measure teacher self-efficacy regarding inclusive education (Alnahdi, 2019c; Loreman et al., 2013; Savolainen et al., 2012; Yada et al., 2018). The previous validations and applications of the TEIP scale were performed in studies of primary and secondary school teachers, as well as student teachers, in several countries. A few involved kindergarten teachers (Özokcu, 2018a, 2018b); however, none focused on kindergarten settings in Saudi Arabia. Therefore, the current study aims to use the TEIP scale to measure kindergarten teachers' self-efficacy regarding inclusive education. Given that it has not been used previously in this setting, it is important that the reliability and validity of the scale for Saudi inclusive kindergarten teachers is also examined.

The ORI scale has been used to measure teacher attitudes towards inclusive education at multiple education levels in several countries (Ewing et al., 2018). The ORI has been administered to in-service kindergarten teachers (Emam & Mohamed, 2011; Özokcu, 2018b; Sari et al., 2009), pre-service kindergarten teachers (Rakap et al., 2017), and primary and secondary school teachers (Galaterou & Antoniou, 2017; Jamsai, 2018). It has exhibited good reliability and acceptable validity (Antonak & Larrivee, 1995). The ORI has been successfully used, validated, and translated into Arabic to measure Saudi primary and secondary school teachers' attitudes towards inclusive education (Adhabi, 2018; Al-Ahmadi, 2009, Alhudaithi, 2015; Alqahtani, 2017; Alquraini, 2011,2012). However, the ORI scale has not been used to measure Saudi kindergarten teachers' attitudes towards inclusive education. Therefore, this study aims to use the ORI scale to measure kindergarten teachers' attitudes towards inclusive education. In addition, its reliability and validity when used with Saudi kindergarten teachers will be examined.

Research Questions:

- 1.1 How valid is the Teacher Efficacy for Inclusive Practices (TEIP) scale for measuring teachers' self-efficacy in the Saudi inclusive kindergarten context?
- 1.2 How reliable is the TEIP scale in the Saudi inclusive kindergarten context?
- 1.3 How valid is the Opinions Relative to the Integration of Students with Disabilities (ORI) scale for measuring teachers' attitudes in the Saudi inclusive kindergarten context?
- 1.4 How reliable is the ORI scale in the Saudi inclusive kindergarten context?

4.3.2. Research Aim 2

Aim: To examine Saudi kindergarten teachers' self-efficacy and attitudes towards inclusive education.

Rationale: Teacher self-efficacy and attitudes are crucial to the successful implementation of inclusive education. Teacher self-efficacy has been found to be an indicator of the ability to teach, to manage the behaviour of children with disabilities in regular classrooms, and to collaborate with school staff and parents (Emam & Mohamed, 2011; Savolainen et al., 2012; Weisel & Dror, 2006; Woodcock & Faith, 2021; Yada et al., 2018). Several research studies have emphasised the importance of recognising teacher attitudes towards inclusive education because of their influence on teachers' behaviours with children with disabilities in regular classrooms (Avramidis & Norwich, 2002; Dymond et al., 2008; Hsieh et al., 2012; Yada et al., 2018). Thus, positive teacher attitudes are fundamental to the successful implementation of inclusive education. Negative teacher attitudes will negatively influence implementation. This can lead to unequal treatment for children with disabilities (Avramidis & Norwich, 2002).

Several studies have demonstrated that teachers' high self-efficacy significantly influenced their implementation of inclusive education and correlated positively with their attitudes towards inclusive education (Emam & Mohamed, 2011; Savolainen et al., 2012; Weisel & Dror, 2006; Woodcock & Jones, 2020; Yada et al., 2018). These studies reflect that teachers' self-efficacy in inclusive education relates to their attitudes towards inclusive education and whether they will, in turn, exhibit positive or negative inclusionary behaviour.

Studies have examined teacher self-efficacy and attitudes towards inclusive kindergarten education in several countries (e.g., Emam & Mohamed, 2011; Hsieh & Hsieh, 2012; Özokcu, 2018a, 2018b; You et al., 2019). However, in Saudi Arabia, few studies have focused on teacher self-efficacy and attitudes towards inclusive education. Previous studies have focused on primary and secondary schools or the inclusion of students with specific types of disabilities (e.g., Adhabi, 2018; Al-Ahmadi, 2009; Alamri, 2014; Alhudaithi, 2015; Alnahdi, 2019a; Al-Quraini, 2012). To date, Saudi teachers' self-efficacy and attitudes towards the inclusion of all children with disabilities in kindergarten settings have not been examined. As previously noted, teacher self-efficacy and attitudes are instrumental in ensuring the implementation of best practices. Thus, they should be considered in examinations of inclusive education in kindergartens in Saudi Arabia. This study aims to investigate Saudi kindergarten teachers' self-efficacy and attitudes towards inclusive education.

Research Questions:

The following research questions will be investigated via a quantitative survey.

- 2.1 What are Saudi kindergarten teachers' levels of self-efficacy towards inclusive education as measured by Teacher Efficacy for Inclusive Practices (TEIP)?

- 2.2 What are Saudi kindergarten teachers' attitudes towards inclusive education settings as measured by Opinions Relative to the Integration of Students with Disabilities (ORI)?
- 2.3 What is the difference between Saudi general education and special education teachers' self-efficacy in inclusive education in kindergarten settings?
- 2.4 What is the difference between Saudi general education and special education teachers' attitudes towards inclusive education in kindergarten settings?
- 2.5 What is the relationship between Saudi teachers' self-efficacy and attitudes towards inclusive education in kindergarten settings?

4.3.3. Research Aim 3

Aim: To investigate the influence of teacher-, child-, and context-related factors on Saudi teacher self-efficacy and attitudes towards inclusive education in kindergarten settings.

Rationale: Previous studies have highlighted the influential factors in teacher self-efficacy and attitudes towards inclusive education (Alamri, 2014; Avramidis & Norwich, 2002; Emam & Mohamed, 2011). These factors can be classified as follows: (a) teacher-related, such as age, teaching position, teaching experience, training, and having a family member, close relative, or friend with a disability; (b) child-related, such as disability type and severity; and (c) context-related, such as physical support (class size, education policy support, and resource availability, including materials and equipment) and personnel support (availability of special aides or teacher assistants and collaboration with administrators, parents, and other teachers).

The literature review revealed that most of the few international studies have produced inconsistent results with regard to the influence of teacher-related factors (age,

teaching position, teaching experience, training, and having a family member, close relative, or friend with a disability) on kindergarten teachers' self-efficacy and attitudes towards inclusive education (Batu et al., 2017; Dias & Cadime, 2016; Emam & Mohamed 2011; Fakhri, 2019; Lee et al., 2014 Özkücü, 2018a; Parasuram, 2006; Štemberger & Kiswarday, 2018; You et al., 2019). A review of the international literature indicated that there is a dearth of research examining the influence of disability type and severity on kindergarten teacher self-efficacy regarding inclusive education. In addition, the focus of the few studies that have been conducted has been only on primary and secondary teachers, and the studies have shown inconsistent results (Hofman & Kilimo, 2014; Yada & Savolainen, 2019). Regarding teachers' attitudes, a few international studies have examined the influence of disability type and severity on kindergarten teachers' attitudes towards inclusive education (Batu et al., 2017; Fakhri, 2019; Gezer & Aksoy, 2019). These studies have also yielded inconsistent results.

The review of the literature indicated the paucity of international research on the influence of context-related factors on teachers' self-efficacy and attitudes towards inclusive education at all educational levels, including kindergarten. The findings generally indicated that teachers who perceived the existence of sufficient physical and personnel support had higher self-efficacy and more positive attitudes towards inclusive education than teachers who did not (Chiner & Cardona, 2013; Fyssa et al., 2014; Hosford & O'Sullivan, 2016).

In Saudi Arabia, the influence of teacher-, child-, and context-related factors on kindergarten teachers' self-efficacy and attitudes towards inclusive education has not been empirically examined. The findings of the few studies that have addressed the influence of teacher-, child-, and context-related factors on primary and secondary school teachers' attitudes towards inclusive education have been inconsistent (Adhabi, 2018; Al-Ahmadi,

2009; Alamri, 2014; Alhudaithi, 2015; Al-quraini, 2012). The influence of these factors on Saudi primary and high school teacher self-efficacy regarding inclusive education has not been addressed and this is true also for the kindergarten setting. Thus, the current study aims to fill this gap in the national and international literature by investigating the influence of teacher-, child-, and context-related factors on both teacher self-efficacy and attitudes towards inclusive education in kindergarten settings in Saudi Arabia.

Research Questions:

The first of the research questions that follow (3.1–3.6) will be investigated via a quantitative questionnaire, and the remaining research questions below (3.7 and 3.8) will be investigated via semi-structured qualitative interviews.

- 3.1 How do **teacher-related** factors (age; teaching position; years of teaching experience in general education; years of teaching experience in special education; years of teaching experience in inclusive education; training about children with disabilities or in inclusive education; and having a family member, close relative, or friend with a disability) **influence teacher self-efficacy** in inclusive Saudi kindergarten settings?
- 3.2 How do **teacher-related** factors (age; teaching position; years of teaching experience in general education, years of teaching experience in special education, years of teaching experience in inclusive education; training about children with disabilities or in inclusive education; and having a family member, close relative, or friend with a disability) **influence teacher attitudes** towards inclusive education in Saudi kindergarten settings?
- 3.3 What is teachers' self-efficacy regarding the inclusion of **children with specific types of disabilities** in Saudi kindergarten settings? (child-related factor)

- 3.4 What are teachers' attitudes towards the inclusion of **children with specific types of disabilities** in Saudi kindergarten settings? (child-related factor)
- 3.5 How do **context-related** factors (class size and number of special education teachers) influence Saudi **teachers' self-efficacy** in inclusive kindergarten settings?
- 3.6 How do **context-related** factors (class size and number of special education teachers) influence Saudi **teachers' attitudes** towards inclusive education in kindergarten settings?
- 3.7 What are the reported factors influencing Saudi general and special education teachers' self-efficacy in inclusive education in Saudi kindergarten settings?
- 3.8 What are the reported factors influencing Saudi general and special education teachers' attitudes towards inclusive education in Saudi kindergarten settings?

4.3.4. Research Aim 4

Aim: To explore teachers' perceptions of the barriers to inclusive education in Saudi kindergarten settings.

Rationale: It has been emphasised that for inclusive education to be successful, teachers' concerns about the barriers to implementation in their regular classrooms must be identified and addressed (Alhammad, 2017; Alquraini, 2011; Bhatnagar & Das, 2014; Forlin et al., 2008; Lee et al., 2014; Woodcock & Woolfson, 2019).

A few international studies have identified common teacher-perceived barriers to the successful implementation of inclusive education. These include the lack of support from Principals and parents, lack of collaboration between teachers, lack of funding, lack of physical and personnel resources, lack of policy support, and negative understanding of disabilities (Chiner & Cardona, 2013; Fyssa et al., 2014; Gezer & Aksoy, 2019; Purdue, 2009; Smith & Smith, 2000; Woodcock & Woolfson, 2019).

In Saudi Arabia, there is a dearth of research on teacher perceptions of the barriers to the implementation of inclusive education in kindergarten settings. A few studies have identified teacher perceptions of the barriers to the inclusion of students with specific types of disabilities in primary and secondary settings. The barriers include large class sizes, inappropriate curricula and physical environments, poor communication with parents, and the lack of special aides or teaching assistants, teaching materials, inclusive education training, Principal support, and collaboration between teachers (Alamri, 2014; Alhammad, 2017; Alquraini, 2011, 2012).

As shown above, a few international studies have examined the barriers to inclusive education in kindergarten settings. In Saudi Arabia, however, there is no research on the barriers to inclusive education in kindergarten, although a few studies have examined the issue in primary and secondary settings. Thus, the current study aims to explore teachers' perceptions of the barriers to inclusive education in Saudi kindergartens. It will fill the gap in the Saudi literature and contribute to the international literature. Moreover, the study will identify the barriers and the best approaches to addressing them to facilitate the implementation of effective inclusive practices to benefit all children.

Research Questions:

The following research question will be investigated via a quantitative questionnaire and semi-structured qualitative interviews.

- 4.1 What are Saudi kindergarten teachers' perceptions of the barriers to the successful inclusion of children with disabilities in kindergarten settings?

4.4. Significance of the Study

This study is significant because it extends the current knowledge by providing psychometric information on the adapted scales. This will strengthen the findings and support future research on teacher self-efficacy and attitudes towards inclusive education in kindergartens. It also provides insights into kindergarten teachers' self-efficacy and attitudes towards inclusive education; the influence of teacher-, child-, and context-related factors on teachers' self-efficacy and attitudes; and teachers' perceptions of the barriers to the successful inclusion of children with disabilities in kindergartens.

Most school districts globally, including in Saudi Arabia, face challenges in supporting children with disabilities in inclusive settings, despite a policy commitment to inclusive education. This study seeks to contribute to finding a solution to such challenges. This research will offer new insights for decision-makers and policymakers in the country's Ministry of Education. The findings will be useful in the development and implementation of policies and strategies to enhance teacher self-efficacy and attitudes, which have been found to be crucial for the effective implementation of inclusive education. Because this study will be the first of its kind in Saudi Arabia, the outcomes can also provide directions for further research on the inclusion of children with disabilities in kindergarten settings in the country.

This study used a convergent mixed-methods approach to examine Saudi kindergarten teachers' self-efficacy and attitudes towards inclusive education. Mixed-methods designs have not often been applied in inclusive education research internationally or, specifically, in Saudi Arabia. Importantly, this study will make a significant contribution to the field via its methodology. The use of quantitative and qualitative approaches will

facilitate corroboration and increase the breadth and depth of the understanding of the issue while offsetting the weaknesses inherent in each approach.

4.5 Summary

The study aims identified in this chapter will contribute to filling the gaps in knowledge about teacher self-efficacy and attitudes towards inclusive education in Saudi kindergarten settings, in addition to the influence of teacher-, child-, and context-related factors on teachers' self-efficacy and attitudes. It will also increase the understanding of teacher perceptions of the barriers to inclusive education in kindergarten settings. As this study is the first attempt to explore Saudi kindergarten teachers' self-efficacy and attitudes towards inclusive education, it also aims to provide psychometric information on well-established scales. This psychometric testing will strengthen the current study's findings and support future research on teacher self-efficacy and attitudes toward inclusive education in kindergartens. The following chapter will discuss the methodology designed to address the research aims and questions.

Chapter 5: Methodology

5.1 Introduction

This chapter provides a comprehensive presentation of the methodology designed to address this study's specific research aims and research questions. The study employed a convergent mixed-methods design comprising quantitative (questionnaires) and qualitative (interviews) approaches. This chapter discusses the purpose of mixed-methods research and provides a rationale for employing a convergent mixed-methods research design. The chapter also describes the sample participants and describes the research materials and the procedures for translation and data collection. The chapter then details the methods used in the data analysis for the study's two approaches. Lastly, the chapter discusses the ethical issues relating to this research.

5.2 Research Design

Mixed-methods research is essentially the investigation of an issue by a variety of different methods and generally includes combining complementary quantitative and qualitative techniques (Creswell & Plano Clark, 2018; Edmonds & Kennedy, 2016; Jason & Glenwick, 2016). This study employed a convergent mixed-methods research design, which "involves the separate collection and analysis of quantitative and qualitative data" (Creswell, 2014, p. 36). The intent of a convergent design is to bring together the two data bases "in a discussion where they are arrayed side by side. For example, the quantitative results may be reported first, followed by the qualitative results" (Creswell, 2014, p. 36).

The utility of the mixed-methods approach depends upon the philosophical preconceptions of the researcher. From a social science perspective, positivist philosophy advocates for a quantitative approach to empirical research, as this focuses on the research data being objective, observable, and measurable to form an understanding of “reality.” (Michell, 2003). Conversely, in a qualitative approach, subjectivist, constructivist, and hermeneutic philosophy centre upon “meaning” and “reflexivity” (Creswell, 2014; Creswell & Plano Clark, 2018; Edmonds & Kennedy, 2016). Despite the long history of the mixed-methods approach, it has only newly become a mainstream approach to empirical research, and one which is now viewed as offering greater insights than a single-method approach.

The increased acceptance of the mixed-methods approach has occurred primarily due to the downfall of positivist hegemony (Bergman, 2008). This allowed for a more open-minded approach to research methodology. Over time, it became more acceptable to experiment with combining research methods that were once seen to be incompatible (Heyvaert et al. 2013; Johnson & Onwuegbuzie, 2004). Perhaps the most noteworthy reason for the acceptance of the mixed-methods approach is the significant advantages that occur in practice.

Greene (2007) highlights five primary benefits of a mixed-methods approach. The first is “triangulation,” which is the art of using multiple methods to research the issue from a variety of perspectives. The second is “complementarity,” which is where different methods create a range of data types, allowing the researcher to get a more comprehensive understanding of the issue. The third is “development,” whereby different methods elucidate the research problem by demonstrating how other methods can be enhanced. The fourth is “initiation,” which highlights that using multiple methods increases the possibility of

discovering or locating issues with the models or theories that are the subject of the research. Lastly, “expansion” focuses on increasing the range of methodological techniques used, which generally leads to a larger number of new theories, models, and research projects when compared to single-method approaches. While all five reasons are persuasive, the advantages that arise from “triangulation” and “complementarity” were the most compelling reasons to use a mixed-methods approach for the current study. A mixed-methods approach will satisfy the aims of the study and answer its research questions in a comprehensive manner.

It should be noted, however, that a mixed-methods approach is not considered to be a valid methodology by all researchers. Philosophically, some researchers have contended that issues arise due to the division between the quantitative and qualitative methods. For instance, Giddings (2006) suggests that the labels of “qualitative” and “quantitative” exacerbates their binary positioning and alienates the range of different methodologies within them. Bergman (2008) concludes that the distinction between quantitative and qualitative is insincerely retained to safeguard the reputation of noteworthy researchers. Other critiques of the mixed-methods approach have arisen due to a lack of recognition of the differences between qualitative and quantitative principles (Michell, 2011). As has been seen above, whilst the mixed-methods approach can be used incorrectly, it is not the case that a mixed-method approach is inferior to a single-method approach, or that the empirical conclusions drawn from them are misconceptions (Teddlie & Tashakkori, 2010). Therefore, a mixed-methods approach was appropriately applied in this study to address the research aims and questions and provided a superior methodological design for the current study.

As noted above, this study adopted a convergent mixed-methods design, which involved the separate collection and analysis of data through both a quantitative

questionnaire and a qualitative semi-structured interview approach, with both occurring during a similar timeframe (Creswell, 2014; Creswell & Plano Clark, 2018; Edmonds & Kennedy, 2016). The quantitative questionnaires were completed first in close proximity to the period during which the qualitative semi-structured interviews were conducted; data from both questionnaires and interviews were analysed during a similar timeframe. The quantitative questionnaire gives an overall description of Saudi teachers' self-efficacy and attitudes towards inclusive education in kindergarten settings. This is achieved by examining how teachers report their self-efficacy and attitudes towards inclusive education. The questionnaire also examines to what extent teacher-related, child-related and context-related factors are associated with the teachers' self-efficacy and attitudes towards inclusive education. The questionnaire includes the identification of the barriers to inclusive education via closed questions. In contrast, the qualitative interview approach enables exploration of why teachers exhibit either high or low levels of self-efficacy and attitudes towards inclusive education, and facilitates an open exploration of the barriers to inclusive education in Saudi kindergarten settings.

The convergent mixed-methods design was appropriate for the current study since the quantitative and qualitative data collection methods contribute to complementarity. Thus, more informed and comprehensive understandings are formed about Saudi kindergarten teachers' self-efficacy and attitudes, the factors influencing their self-efficacy and attitudes, and their perceptions of the barriers to inclusive education in Saudi kindergarten settings. Both the quantitative and qualitative approaches provide different insights, and their combination enables the researcher to gain a more complete and verified account of the current research problem than would have been provided by only one approach (Creswell & Plano Clark, 2018; Edmonds & Kennedy, 2016; Flick, 2018).

5.3 Participants

5.3.1 Questionnaire Participants

The questionnaire participants included kindergarten general education teachers, who have a bachelor's degree in Early Childhood Education, and special education teachers, who have a bachelor's degree in Special Education. These participants worked in public inclusive kindergartens in Riyadh, the capital city of Saudi Arabia. Riyadh was selected because it has the highest number of inclusive kindergartens. In Saudi Arabia, all kindergarten teachers are female because the education system does not allow for co-education, which means female and male teachers are not allowed to be in the same schools (Abduljawad et al., 2008). Consequently, all questionnaire and interview participants were female. In constructing the sampling frame, the number of kindergartens and teachers was obtained from recent statistical data for 2014 to 2015 posted on the Ministry of Education website. According to the Ministry of Education (2016a), Riyadh had 454 public and private kindergartens and 4,407 kindergarten teachers. Of this number, there were 34 inclusive kindergartens, 340 general education teachers, 74 special education teachers and a total enrolment of 393 children with disabilities, as well as four private inclusive kindergartens with 16 children with disabilities.

The demographic information of the participants in the quantitative questionnaire is summarised in Table 5.1 below. In the present study, 237 general education teachers (79.3%) and 62 special education teachers (20.7%), all of whom worked in public inclusive kindergartens, were the final sample for the study's quantitative phase. A majority of the participants 187 (62.5%) were aged from 30 to 39 years. The highest qualification obtained by most of the participants was a bachelor's degree (254, 84.9%). A majority of the special

education teachers specialised in either intellectual disabilities (29, 46.7%) or hearing disability (28, 45.1%). Around three quarters (227, 75.9%) of the participants had less than 16 years of teaching experience in general education while 39 (13%) had less than 20 years teaching experience in special education and 225 (75.2 %) had less than 6 years of teaching experience in inclusive education. A majority of the participants 185 (61.8 %) reported having from 21 to 30 children with and without disabilities in their inclusive classrooms. A notable finding is that 298 (99.6%) of the participants had no special aides in their inclusive classrooms. The participants were asked about the number of special education teachers who work in their inclusive kindergarten and just over half of the participants 154 (51.5%) were working in kindergarten settings that had 1–3 special education teachers. A majority of the participants 228 (76.3%) had not undertaken any training about children with disabilities or in inclusive education. Finally, most of the participants 235, (78.6%) did not have any family member, close relative, or friends with disabilities.

Table 5.1*Summary of Demographic Information of Questionnaire Participants*

Characteristic	Category	Frequency	Percent
Teaching position	General	237	79.2
	Special	62	20.7
Age	Under 30 years	14	4.6
	30–39 years	187	62.5
	40– 49 years	95	31.7
	Over 50 years	3	1.0
Highest qualification	Diploma	39	13.0
	Bachelor	254	84.9
	Master	6	2.0
Area of specialisation	Intellectual disabilities	29	46.7
	Hearing disabilities	28	45.1
	Visual disabilities	5	8.0
Years teaching experience in general education	Under 6 years	102	34.1
	6–10 years	83	27.7
	11–15 years	42	14.0
	16–20 years	31	10.3
	Over 20 years	41	13.7
Years teaching experience in special education	Under 6 years	28	45.1
	6–10 years	9	14.5
	11–15 years	8	12.6
	16–20 years	2	3.2
Years teaching experience in inclusive education	Under 6 years	225	75.2
	6–10 years	38	12.7
	11–15 years	26	8.6
	16–20 years	6	2.0
	Over 20 years	4	1.3
Class Size	1–20	52	17.3
	21–30	185	61.8
	More than 30	62	20.7
Do you have special aides in your classroom?	Yes	1	0.3
	No	298	99.6
Number of special education teachers in inclusive classroom	1–3	154	51.5
	4–6	136	45.4
	7–10	9	3.0
Have you attended any training about children with disabilities or in inclusive education?	Yes	71	23.7
	No	228	76.3
Do you have any family member or close relative or friends with disabilities?	Yes	64	21.4
	No	235	78.6

5.3.2 Semi-structured Interview Participants

The study's qualitative element used a purposive sample of eight teachers. The purposive sample comprised four special education teachers and four general education teachers working in public inclusive kindergartens in Riyadh, the capital city of Saudi Arabia. Since the qualitative interview method for this study aimed to explore the factors influencing teachers' high or low levels of self-efficacy and attitudes towards inclusive education and their perception of the barriers to inclusive education in their kindergarten settings, stratified purposeful sampling techniques were used. The questionnaire asked teachers if they would consent to being interviewed; participants who provided this consent were the sampling frame for the interviews. The teachers from this sampling frame were divided into two strata based on the teachers' self-rating of: (1) self-efficacy (on the TEIP scale); and (2) attitude (on the ORI scale) towards inclusive education. Subdivision of this strata was conducted to organise teachers according to their positive or less positive self-reports of self-efficacy and attitude towards inclusive education. Consequently, the four strata were: (1) two general education teachers with positive self-efficacy and attitude towards inclusive education, (2) two general education teachers with less positive self-efficacy and attitude, (3) two special education teachers with positive self-efficacy and attitude towards inclusive education, and (4) two special education teachers with less positive self-efficacy and attitude.

5.4 Instrumentation

5.4.1 Questionnaire

The quantitative data were collected using a four-section questionnaire designed for the study (see Appendix A). The questionnaire sections were entitled: (1) Demographic Information, (2) Kindergarten Teachers' Self-Efficacy in Inclusive Education, (3) Kindergarten Teachers' Attitudes Towards Inclusive Education, and (4) Kindergarten Teachers' Perceptions of the Barriers to Inclusive Kindergartens.

5.4.1.1 Section 1: Demographic Information

The first section of the questionnaire contained 11 items that focused on understanding the teachers' background information, including age, education level, current teaching position (special or general education), years of teaching experience in kindergartens, number of children with and without disabilities in their classroom, number of special aides in their classroom, training about children with disabilities or in inclusive education, and having a family member, close relative, or friend with disabilities. In this section, the demographic information captured teacher- and context- related factors (see Appendix A).

5.4.1.2 Section 2: Kindergarten Teachers' Self-efficacy in Inclusive Education

The questionnaire's second section consisted of two parts. The first included the Teacher Efficacy for Inclusive Practices (TEIP) scale which was adapted from Sharma et al., (2012). This scale was used to investigate Saudi kindergarten teachers' self-efficacy in inclusive education. The TEIP scale was translated into the Arabic language (see the questionnaire procedure section 5.5.1.1). The TEIP scale includes 18 positive statement items divided evenly into three factors: (1) Efficacy to use inclusive instructions (EII; items

5, 6, 10, 14, 15, and 18); (2) Efficacy in collaboration (EC; items 3, 4, 9, 12, 13, and 16); and (3) Efficacy in managing behaviour (EMB; items 1, 2, 7, 8, 11, and 17). Examples of these items for each factor are presented in Table 5.2. The original study on the TEIP scale was conducted on a sample of 607 pre-service teachers from four countries—Canada, Australia, Hong Kong, and India (Sharma et al., 2012). It proposed the three-factor structure of the scale based on exploratory factor analysis. The Cronbach's alpha coefficient for the internal consistency reliability of the original TEIP scale was reported to be 0.89 for the total scale score and for its three factors of EIL, EC and EMB these coefficients were 0.93, 0.85, and 0.85, respectively, which indicated sufficient reliability (Sharma et al., 2012). The original TEIP scale was utilised and adapted for this study with rewording modifications based on the study's purpose. Only two words were changed: "children" was used instead of "students" and "kindergarten" instead of "school," as the study focuses specifically on the context of kindergarten. A 5-point Likert type scale (strongly agree = 5, agree = 4, neutral = 3, disagree = 2, and strongly disagree = 1) was used. According to Leedy and Ormrod (2012), Likert scales are effective in studies that examine the participants' attitudes towards the topic under investigation.

Table 5.2*Examples of the Adapted TEIP Scale Items for Each Factor*

TEIP factor	Example of items
Efficacy to use inclusive instructions (EI; items 5, 6, 10, 14, 15, and 18)	(14) I can use a variety of assessment strategies (for example, performance-based assessment, child observations, portfolios, etc.).
Efficacy in collaboration (EC; items 3, 4, 9, 12, 13, and 16)	(12) I can collaborate with other professionals (e.g., itinerant teachers or speech pathologists) in designing educational plans for children with disabilities.
Efficacy in managing behaviour (EMB; items 1, 2, 7, 8, 11, and 17)	(7) I am confident in my ability to prevent disruptive behaviour in the classroom before it occurs.

In the second part of this section, which was informed by the research literature and developed by the researcher, teachers were asked to respond to eight ranking questions about how confident they would feel with including children with different types of disabilities in their classroom. The purpose of this question was to capture the child-related factor in order to examine the influence of this factor on teachers' reported self-efficacy in teaching children with various disabilities (see Appendix A).

5.4.1.3 Section 3: Kindergarten Teachers' Attitudes Towards Inclusive Education

The questionnaire's third section had two parts. The first part included the adapted scale of the Opinions Relative to the Integration of Students with Disabilities (ORI; Antonak & Larrivee, 1995). The original ORI scale is a modified version of the Opinion Relative to Mainstreaming (ORM) scale, which Cook and Larrivee designed in 1979. In this study, the adapted ORI scale was used to investigate Saudi kindergarten teachers' attitudes toward inclusive education (see Appendix A). The ORI scale was translated into the Arabic language (see the questionnaire procedure section 5.5.1.1).

The ORI is a 25-item scale that is categorised into four different factors. The first factor is Benefits of integration (BI), and it has eight items: 3, 7, 11, 14, 17, 20, 21, and 24; the second factor is Integrated classroom management (ICM), and it has 10 items: 1, 4, 6, 9, 12, 15, 16, 18, 22, and 25; the third factor is Perceived ability to teach students with disabilities (PA), and it has only three items: 2, 10, and 19; the fourth factor is Special versus integrated general education teachers (SVG), and it has four items: 5, 8, 13, and 23. In the ORI scale, there are 12 negative statements, and these are items 2, 4, 6, 8, 9, 11, 12, 14, 18, 20, 23, and 24. The ORI also has 13 positive statements in items 1, 3, 5, 7, 10, 13, 15, 16, 17, 19, 21, 22, and 25. Examples of these items for each factor are presented in Table 5.3. The construct validity of the original ORI was tested and confirmed by using a hierarchical multiple regression analysis (Antonak & Larrivee, 1995). The Cronbach's alpha coefficient for internal consistency of the original ORI scale was .88, indicating sufficient reliability (Antonak & Larrivee, 1995).

To fit the purpose of the current study, three words were adapted in the ORI scale. The adapted words were “inclusion” in place of “integration,” “children” in place of “students,” and “inclusive classroom” in place of “public schools.” The change from “integration” to “inclusion” ensured the wording was more in line with the Saudi Arabian context. Similarly, “students” was adapted to “children”, and “public schools” to “inclusive classroom” as the study focuses specifically on the context of kindergarten inclusive education. A 5-point Likert scale (strongly agree = 5, agree = 4, neutral = 3, disagree = 2, and strongly disagree = 1) was used for this scale.

Table 5.3*Examples of the Adapted ORI Scale Items for Each Factor*

ORI factor	Example of items
Benefits of integration (BI; items 3, 7, 11, 14, 17, 20, 21, and 24)	(3) Inclusion offers mixed group interaction that will foster understanding and acceptance of differences among children (a positive statement). (11) The presence of children with disabilities will not promote acceptance of differences on the part of children without disabilities (a negative statement).
Integrated classroom management (ICM; items 1, 4, 6, 9, 12, 15, 16, 18, 22, and 25)	(1) Most children with disabilities will make an adequate attempt to complete their learning tasks (a positive statement). (4) It is likely that the child with disability will exhibit behaviour problems in an inclusive classroom (a negative statement).
Perceived ability to teach students with disabilities (PA; items 2, 10, and 19)	(2) Inclusion of children with disabilities will necessitate extensive retraining of general classroom teachers (a negative statement). (10) General classroom teachers have the abilities necessary to work with children with disabilities (a positive statement).
Special versus integrated general education teachers (SVG; items 5, 8, 13, and 23)	(5) Children with disabilities can best be served in inclusive classrooms (a positive statement). (23) Teaching children with disabilities is better done by special education teachers instead of general classroom teachers (a negative statement).

The researcher developed the second part of this section, which also used a 5-point Likert scale (strongly agree = 5, agree = 4, neutral = 3, disagree = 2, and strongly disagree = 1). The questions in this part asked the teachers to indicate the extent they agreed that

children with specific disabilities should be included in an inclusive classroom. The purpose of this question was to capture a child-related factor in order to examine teachers' attitudes toward the inclusion of children with specific disabilities (see Appendix A).

5.4.1.4 Section 4: Teachers' Perceptions of the Barriers to Inclusive Education

This section consisted of one question developed by the researcher. It was a ranking question of 13 items that asked teachers to rank the most significant barriers limiting the inclusion of children with disabilities in an inclusive classroom (see Appendix A).

5.4.1.5 Section 5: Consent to Interview

In the questionnaire's last section, participants were asked if they would be willing to meet with the researcher at their convenience to take part in a brief audio-recorded interview. If so, they were required to provide their name and either telephone number or email address so the researcher could contact them to arrange an interview.

5.4.2 *Semi-structured Interview*

For collecting the qualitative data, a semi-structured interview was used. A semi-structured interview is founded on a set of questions that have been pre-determined by the researcher; however, due to its flexibility, the interviewer can modify the words and re-order the questions during the interview process (Cohen et al., 2013). In the current study, semi-structured interviews were used to: (1) explore the factors influencing teachers' positive and less positive self-efficacy and attitudes, and (2) explore their perception of the barriers to inclusive education in their kindergarten settings.

Open-ended interview questions, which were established on the basis of previous research, were grouped into three categories (see Appendix C). First, questions 1 to 4 were asked to explore the factors influencing kindergarten teachers' attitudes towards inclusive

education (Alamri, 2014, Hsieh & Hsieh, 2012; Wong & Cumming, 2010). Second, questions 5 to 6 were asked to explore the factors influencing kindergarten teachers' self-efficacy in inclusive education (Alamri, 2014, Sharma et al., 2012). Finally, question 7, concerned teachers' perceptions of the barriers to inclusive education in their kindergarten settings.

5.5 Procedure

5.5.1 Questionnaire Procedure

5.5.1.1 Translation

The original TEIP and ORI scales have been translated from English to the Arabic language. These scales were adapted so that they could be applied in Saudi primary and secondary school contexts with the aim of measuring teachers' self-efficacy and attitudes towards inclusion of students with specific types of disabilities (Adhabi, 2018, Alhudaithi, 2015; Alnahdi, 2019; Alquraini, 2011, 2012). Since there was no Arabic translation of the scales for a kindergarten setting, the current study adapted the TEIP and ORI scales to ensure they were relevant for a Saudi kindergarten setting. Translating the scales was intended to boost participants' ability to understand and respond to the questions with appropriate ease (see Appendix B). To arrive at the final Arabic version of the scales' questions, the researcher followed the three steps of the back-translation method (Duffy, 2006; Eremenco et al., 2005). In the first step, two bilingual researchers fluent in both Arabic and English were asked to translate the English questions into Arabic. Next, another researcher specialising in English language, who had not seen the original English version, translated the Arabic questions into English. Finally, a bilingual researcher who specialised in Education and the researcher compared the two English versions. Based on this comparison, some words were modified in a few items in the Arabic version.

5.5.1.2 Content-related Validity

The content-related validity of the adapted TEIP and ORI was evaluated using expert panel evaluation. Notably, content-related validity is the degree to which the items that are used in the scale are consistent with the meaning of the variable and a specific sample of the main topics to be assessed (Cohen et al., 2013). A group of experts was formed to assist in determining the content validity of the adapted TEIP scale (Sharma et al., 2012), and adapted ORI scale (Antonak & Larrivee, 1995). Members of the expert team were selected based on their experience in measurement and education. The key determinant was either their knowledge of special and inclusive education or of developing instruments. Moreover, panellists consisted of two special education teachers who were working in inclusive kindergartens and three experts from the Faculty of Special Education at King Saud University. The experts were asked to evaluate the instruments and come up with changes needed to achieve optimal clarity, appearance, wording, usability, and content suitability. The input from the experts, on content-related validity revealed that both adapted scales were clear and were appropriate for measuring Saudi kindergarten teachers' self-efficacy and attitudes towards inclusive education; hence, no further adaptations to items was required.

5.5.1.3 Data Collection

First, before conducting the study, ethical approval was obtained from the Human Research Ethics Committee at Western Sydney University and the Saudi Ministry of Education (see Appendix D). Second, permission for conducting the research in the kindergartens was obtained from the Principals, after arranging meetings between the researcher and the Principals at their kindergartens. Third, the principals were issued an approval letter from the Saudi Ministry of Education informing them about the research.

They were also given consent forms as well as information letters explaining how the teachers were expected to complete the questionnaires to distribute to potential participants (Appendix E). The researcher then left questionnaires for the Principals to invite the teachers to take part in the study. An invitation letter for the teachers contained both the consent form and information letter, including an explanation of the voluntary nature of participating in the research and the confidentiality of the participants' responses (Appendix F). The questionnaires were attached to these consent and information letters. Finally, the teachers were asked to return the questionnaires to the researcher when she revisited the kindergarten one week later.

5.5.2 Semi-structured Interview Procedure

The semi-structured interview sample was recruited from teachers who, in the questionnaire, provided their consent to be interviewed. A total of 24 teachers consented to participate in the interviews. Eight of these teachers were selected purposefully according to their positive or less positive self-reports of self-efficacy and attitude towards inclusive education. This means that the participants who scored one standard deviation above and below the mean were selected to represent those with high and low self- efficacies attitudes. Selected teachers were asked to participate in individual face-to-face interviews that lasted between 30 and 40 minutes. Each individual interview was conducted at a time and place that was convenient for the interviewee. Prior to each interview, the interviewees were provided with information about the researcher's background (including her position, experience, and personal connections) to help the interviewee feel comfortable being open and honest during the interview. Each interview was recorded on tape and subsequently transcribed.

5.6 Analysis of Data

5.6.1 Analysis of *Quantitative* Data

This section will explain how the quantitative data were analysed. Prior to performing the quantitative analyses, the questionnaire responses were entered and coded numerically using Statistical Product and Service Solutions (SPSS) software (Field , 2017). Most of the statistical tests utilised in this study were performed using SPSS. The exception to this was the confirmatory factor analysis (CFA), which was conducted with the Analysis of Moment Structures (AMOS) software, a statistical program for structural equation modelling. To address the research questions, a number of statistical techniques were conducted to analyse the quantitative data. A range of data analyses were performed to address the research aims and associated research questions. Analyses were preceded by data cleaning to eliminate errors and redundancy, ensure accuracy and consistency, and increase data reliability (Hair et al., 2010). Therefore, preliminary analyses of the data were conducted before commencing statistical analyses. These analyses included checking for outliers and assessing assumptions of normality.

Once parametric testing was confirmed to be appropriate, data analysis entailing both descriptive and inferential analyses was conducted, including confirmatory factor analysis, descriptive statistics, T-test, Pearson's correlation coefficient, multiple regression, and the Friedman test. These statistical procedures and their purposes are presented and discussed below.

5.6.1.1 Confirmatory Factor Analysis

To address research questions 1.1 and 1.3 (see Chapter 4) relating to verifying the construct validity of the adapted TEIP and ORI scales, confirmatory factor analysis (CFA)

was utilised. CFA is recognised as one of the most accurate methodological techniques for assessing the construct validity of pre-established scales (Byrne, 2016). It is conducted with prior knowledge about the factor model's structure. This means that prior to commencing the CFA analysis, it is already known which variables are loading on which factors. CFA is, therefore, a technique that assists a researcher not to “explore” but to “reject” or “confirm” the previous knowledge about the structure of the factor model (Hair et al., 2018; Pituch & Stevens, 2016). Therefore, as the TEIP and ORI scales used in this study are already established scales, it was considered more important to test the theoretical relationship between the variables through CFA rather than using explanatory factor analysis (EFA). The use of CFA was preferred over EFA due to its obvious advantages. EFA is commonly conducted as a technique of data reduction and does not provide the necessary verification to establish construct validity (Hair et al., 2018), whereas the CFA technique is widely performed to examine the theoretical relationships between variables and to assess construct validity (Byrne, 2016; Kline, 2016;).

There are many different goodness-of-fit indices that can be utilised to assess the adequacy of a confirmatory factor model. Each of these indices shows different information about the model's fitness, or lack of fitness. There is no generally accepted answer among researchers to the question of which is the best of these fit indices (Hoyle, 1995); consequently, several goodness-of-fit indices were included in the current analysis. Considering a number of recommendations about which goodness-of-fit indices to report (Bentler, 1990; Brown, 2015; Hair et al., 2018; Kline, 2016), the following fit indices were used: chi-square (χ^2), root mean square error of approximation (RMSEA), the comparative fit index (CFI), and the Tucker-Lewis Index (TLI). The following paragraphs will describe these fit indices.

The most important absolute fit index is the model chi-square, which is used to assess the fit of the model (Hair et al., 2018; Harrington, 2009; Kline, 2016). A good model fit to the data is indicated by a non-significant chi-square whereas a poor model fit is indicated by a significant chi-square (Tabachnick & Fidell, 2013). The model chi-square is a fundamental fit index, but often the size of the sample has significant impact on it. Therefore, even if the model is fitting to the data well, the model chi-square will always be statistically significant in large sample sizes (Hair et al., 2018; Harrington, 2009). Moreover, with more variables added to the model, it becomes more difficult to assess the model using chi-square. It is, therefore, not recommended that the chi-square goodness-of-fit test be used as the only measure of model fit (Hair et al., 2018).

The limitations associated with the Chi-square goodness-of-fit index mean that several alternative goodness-of-fit indices also need to be reported. The RMSEA measure is widely used (Hair et al., 2018) and measures the approximate rather than the exact model of fit (Kline, 2016). The lower the RMSEA value, the better the model fits the data (Hair et al., 2018). An RMSEA value of between .05 and .08 can be interpreted as an acceptable fit, and a value above .10 can be interpreted as a poor fit (Browne & Cudeck, 1993).

Additional goodness-of-fit indices used in this research were baseline comparison indices involving CFI and TLI. These particular indices can show the relative improvement that the researcher's model has achieved over the baseline model (Kline, 2013). The indices range in value from 0 to 1, with higher values indicating a better fit (Hair et al., 2018). For these goodness-of-fit indices, a cut-off value close to .90 is widely used (Bentler, 1990).

5.6.1.2 Reliability Analyses

To address research questions 1.2 and 1.4 (see Chapter 4), a reliability test was conducted by using Cronbach's alpha. After assessing the construct validity of the TEIP and

ORI scales, it was essential to then test the internal reliability of the overall refined and validated scales and their factors to obtain a good instrument and address research questions 1.2 and 1.4 (see Chapter 4). Field (2017) states that a questionnaire's internal reliability is calculated through using Cronbach's alpha, a statistical test of the degree to which the questionnaire's different items seem to assess a single construct. Therefore, in the current analysis, to assess whether the questionnaires had an acceptable level of internal reliability, Cronbach's alpha was calculated. A Cronbach's alpha value of .70 is often considered adequate for internal reliability (Field, 2017; Kline, 2016).

5.6.1.3 Descriptive Analysis

There are different types of descriptive statistics, including mean, standard deviation, frequency, percentage, and mode. Specifically, the mean and the standard deviation are the most frequently used measurements for central tendency and variability (Gay et al., 2012). In the present research, the mean and standard deviation were calculated to address research questions 2.1, 2.3 and 3.4. The statistical software package SPSS (v24.0) was used to produce these descriptive results (Field, 2017).

5.6.1.4 Independent T-test

To address research questions 2.2 and 2.4, an independent t-test was used. This analysis was performed to assess the significant differences in kindergarten teachers' self-efficacy and attitudes towards inclusive education based on their current teaching position in kindergarten settings. An independent t-test was used to compare the general and special education teachers' mean scores on a continuous dependent variable (Creswell, 2015; Field, 2017; Pallant, 2013). Levene's test of equality of variance was also performed to verify that the assumption of homogeneity of variance between two independent groups for the t-test was met (Levene, 1960; Pallant, 2013).

5.6.1.5 Pearson's Correlation Coefficient

In the present study, Pearson's correlation coefficient was used to address research question 2.5. In particular, this technique was used to investigate the relationship between teachers' self-efficacy in inclusive education, as measured by the TEIP total scale and factors (Efficacy to use inclusive instructions, Efficacy in collaboration, and Efficacy in managing behaviour), and their attitudes towards inclusive education, as measured by the ORI total scale and factors (Benefits of integration, Integrated classroom management, and Special versus integrated general education teachers). Pearson's correlation analysis was performed using SPSS (v24.0). Pearson's correlation coefficient is a parametric statistical measure, known as Pearson's r , and is designed to assess the linear relationship between two variables (Field, 2017). Pearson's r is the initial formal test of association (Lee Rodgers & Nicewander, 1988), and one of the most commonly used correlation coefficients (Field, 2017; Lee Rodgers & Nicewander, 1988).

The relationships' values range from -1 to +1 in Pearson's analysis, and the orientation of a relationship (positive or negative association) is revealed by the sign of the coefficient. The size of the absolute value represents the association's strength. A value of +1 or -1 shows a perfect relationship between two variables whereas a value of 0 indicates no relationship between the two variables (Pallant, 2013). This research followed the guidelines suggested by Cohen (1988) for the interpretation of correlation coefficients, where the value of coefficients from .10 to .29 indicate a weak relationship, the value of coefficients from .30 to .49 indicate a moderate relationship, and coefficient values above .50 indicate a strong relationship.

5.6.1.6 Multiple Regression

A standard multiple regression analysis is a statistical technique that can be used to explore the relationship between one dependent variable and two or more independent variables (Pallant, 2013). Standard multiple regression analysis is utilised when the dependent variable is continuous and the independent variables used in the regression are either continuous or categorical (Tabachnick & Fidell, 2013)

The standard multiple regression technique was used to answer research questions 5.2.1, 5.2.2, 5.3.1, and 5.3.2. This technique was applied to determine whether the variance in the continuous dependent variables—teachers' self-efficacy and attitudes towards inclusive education—could be predicted by a mix of continuous and categorical teacher-related and context-related independent variables. For the dependent variables (teachers' self-efficacy and attitudes), the researcher took the sum or mean of five 5-point Likert items or ordinal variables to create a continuous variable (Cohen et al., 2013). The teacher-related independent variables comprised teacher age (continuous), teaching position (categorical), years of teaching experience in general education (continuous), years of teaching experience

in special education (continuous), years of teaching experience in inclusive education (continuous), and training about children with disabilities or in inclusive education (categorical). The context-related independent variables comprised having a family member, close relative, or friend with a disability (categorical); class size (continuous), and number of special education teachers (continuous). Coding for categorical variables in the multiple regression analysis in the present study is presented in Table 5.4.

Table 5.4
Coding of Categorical Variables in the Multiple Regression Analysis

Categorical variable	Level of measurement	Value label
Teaching position	Nominal	General education teacher = 1 Special education teacher = 2
Training	Nominal	Yes = 1 No = 0
Having a family member, close relative, or friend with a disability	Nominal	Yes = 1 No = 0

5.6.1.7 Friedman Test

The Friedman test is an inferential non-parametric statistical test that can be performed with ordinal level data to compare three or more matched or paired variables (Sheskin, 2007). The mean rank scores obtained by the Friedman test are used to rank the variables from highest to lowest (Siegel & Castellan, 1988). In this study, the Friedman test was conducted to answer research questions 3.3 and 4.1, to determine which specific disabilities were ranked by teachers as those they were most to least they were confident about including in their regular classrooms, and to determine the most and least significant barriers to inclusive education in Saudi kindergarten settings.

5.6.2 Analysis of Qualitative Data

To address the qualitative research questions 3.7, 3.8 and 4.1, the current study analysed and reported the interview data through six phases of thematic analysis. In addition, to enhance the trustworthiness of the qualitative data, four fundamental criteria were considered in the study. These were credibility, transferability, dependability, and conformability. The thematic analysis phases and trustworthiness criteria are discussed comprehensively in the relevant subsections.

5.6.2.1 Thematic Analysis

In this study, the collected data from the semi-structured interviews were interpreted and assessed through a thematic analysis technique. This thematic analysis technique is appropriate for the study, as it contributes to enhanced flexibility in exploring interview data (Braun & Clarke, 2006, 2013). The aims of the interviews were to explore the reported factors influencing teachers' high or low levels of self-efficacy and positive or less positive attitudes towards inclusive education, as well as exploring reported barriers to inclusive education in their kindergarten settings. Thus, for identifying the themes from the interviews, a specific analytical technique was required.

Flexibility is the major benefit of thematic analysis, allowing the researcher to identify themes in a number of ways. As Braun and Clarke (2006) state, "a theme captures something important about the data in relation to the research question and represents some level of patterned response or meaning within the data set" (p. 82). This indicates that the significance of a theme is mainly based on its relevance to the research questions rather than involving repetition of words or information.

To conduct thematic analysis, Braun and Clarke (2006) suggest an inclusive framework, referred to as the six basic phases. The phases are: (1) establishing familiarity with the data, (2) generating initial codes, (3) searching for themes, (4) reviewing themes, (5) defining and naming themes, and (6) producing the report. These six phases of thematic analysis may appear simple; however, thematic analysis is an iterative process, which needs to move back and forth between the phases as required, rather than following a linear process of simply shifting from one phase to the next (Braun & Clarke, 2006). In addition, qualitative analysis should be flexible so that it aligns with the research questions and data,

rather than following unwavering rules (Creswell & Plano Clark, 2018). Thus, considering all these aspects, the framework proposed by Braun and Clarke (2006) has been used in the study, as detailed in the next subsections.

5.6.2.2 Establishing Familiarity with the Data

The interviews were conducted and transcribed in the Arabic language and the key quotes were translated into English. Translation of the key quotes was undertaken by a certified translator and then reviewed by the researcher and by a PhD candidate who is bilingual in Arabic and English. After the completion of the translation, an important role of the researcher was to become familiar with the data at this stage by repeatedly reading the interview transcripts. These repeated readings were actively conducted with the objective of searching for patterns and meanings within the data (Braun & Clarke, 2006). Simultaneously, key ideas were identified from the data and were accordingly noted for generating the initial codes for the subsequent phase (Braun & Clarke, 2006; Maxwell, 2013).

5.6.2.3 Generating the Initial Codes

In this phase, the key data were sorted in a systematic way by grouping the relevant data into a number of initial codes (Braun & Clarke, 2006). The reason for generating the initial codes was to sort the data in a meaningful way (Maxwell, 2013). In this stage, the researcher ensured that none of the data was overlooked and the maximum possible patterns of codes were created. Corresponding to arranging data in terms of the initial codes, the notes from the interviews were reviewed again, a process carried out manually in a Microsoft Word document file. This stage concluded with the development of a considerable number of important initial codes, which assisted in properly conducting the next phase of searching for themes.

5.6.2.4 Searching for Themes

In this stage, the emergent themes were identified, which were common across the data from the initial codes developed in the previous step. Specifically, the potential themes were developed from the initial codes and the data relating to each of the potential themes was assembled (Braun & Clarke, 2006). In this phase, with the application of thematic analysis, the specific themes to be used in the study were identified after repeated readings of all coded data related to factors influencing teachers' high or low levels of self-efficacy and attitudes towards inclusive education, and the perceived barriers to inclusive education in their kindergarten settings.

5.6.2.5 Reviewing the Themes

In this phase, the objective was to use a two-step procedure for identifying the accuracy and consistency of the themes. The first step was to read each of the themes to determine whether it is was established in a rational way. Where themes were not developed in a coherent pattern, these were reworked or revised for improved meaningfulness. Correspondingly, the second step was to re-read the dataset to assess whether the themes developed were in alignment with the data, and to identify if any data were ignored at the initial coding stages and needed to be coded within the themes (Braun & Clarke, 2006).

5.6.2.6 Defining and Naming Themes

In this stage, the real meaning of the specific and overall themes was determined. This also helped in identifying the representation of each of the themes. This led to the refining and defining of the identified themes. In addition, a comprehensive analysis was executed and recorded, detailing the information that each particular theme captures. Also in this phase, the way each of the specific theme was related to the dataset as whole and the research questions was also identified and evaluated (Braun & Clarke, 2006). Therefore, in

this study, each theme was considered both individually and in terms of its association with other themes.

In the refinement process, the identified themes were reviewed again to determine whether there were any subthemes. These are important for structuring a comprehensive theme (Braun & Clarke, 2006). In this study, some subthemes were included. In this terminating phase, it was also possible to determine that if some of the themes were irrelevant, they could be ignored. Eventually, in this phase, the themes were precisely and specifically labelled so as to briefly and accurately reflect their scope (Braun & Clarke, 2006).

5.6.2.7 Producing the Report

Writing and producing the report was the sixth and final stage of the thematic analysis. Prior to producing the report, a few meaningful questions should be considered so as to further evaluate the identified themes. “These are: What does this theme mean? What are the assumptions underpinning it? What are the implications of this theme? What conditions are likely to have given rise to it? Why do people talk about this thing in this particular way (as opposed to other ways)? What is the overall story the different themes reveal about the topic?” (Braun & Clarke, 2006, p. 94). By considering these questions, the key points associated with each of the identified themes was clarified. In this phase, the themes identified were reported and discussed and the quotes obtained from the participants were also presented to explain the reported factors influencing teachers’ high or low levels of self-efficacy and attitudes towards inclusive education and reported barriers to inclusive education in their kindergarten settings.

5.6.3 Trustworthiness

The qualitative data's trustworthiness was evaluated through the criteria of credibility, transferability, dependability, and confirmability (Guba & Lincoln, 1985). The implementation of these criteria in the present study is reviewed below.

5.6.3.1 Credibility

Credibility is deemed to be parallel to the concept of internal validity in quantitative research. It defines whether or not the findings from interview data reflect plausible information extracted from the original data of the participants and are a correct interpretation of the original view of the participants (Guba & Lincoln, 1989; Tobin & Begley, 2004). Therefore, in order to achieve credibility, it was imperative to accurately represent the perspective of the participants in the reported findings. To assess the credibility of the findings, peer debriefing and triangulation were conducted.

The aim of peer debriefing is to minimise the bias of a researcher (Guba & Lincoln, 1989). In the current study, this was used to provide quality assurance through seeking input from an independent peer reviewer. The peer reviewer was a PhD researcher who was experienced and trained in qualitative data analysis. The reviewer helped in assessing the collected and analysed data and was asked to check the transcriptions of the interviews by comparing the recordings with the transcriptions. Frequent meetings with the reviewer were conducted throughout the research process to discuss the development of the coding framework and to reach mutual agreement on the themes. This method was extremely beneficial as it provided a different analytical viewpoint from which to consider the collected data.

The second approach used in this study to ensure credibility was triangulation. This technique is common and useful because it uses multiple sources to improve research validity (Robson & Kieran, 2016). The data sources for this study involved a questionnaire distributed to the whole study sample and semi-structured interviews performed with a sub-sample of those who answered the questionnaire. The use of these two data sources in the analysis was particularly beneficial in improving data interpretation, as the use of both data sources assisted the researcher to look at the research problem from multiple angles. This is especially important for complex constructs such as self-efficacy and attitude, as multiple approaches need to be used to explore these constructs, because they cannot be fully understood through using purely quantitative or purely qualitative approaches (Teddlie & Tashakkori, 2010).

5.6.3.2 Transferability

Transferability has been identified as similar to the concept of the external validity of quantitative research (Guba & Lincoln, 1989). The term transferability refers to a judgement as to whether the working hypothesis of a researcher applies to various contexts (Zhang & Wildemuth, 2009). Nevertheless, this judgement is largely related to the reader rather than the researcher. Transferability was developed in the current study by offering thick description of the methodological procedures used, the demographic characteristics of the participants, and the setting in which the study was conducted. All of this information might allow a decision to be made on the transferability of the findings to a different context. According to Mertens (2014), the responsibility of transferability is on the reader to assess the degree of similarity between the site of study and the receiving context. The responsibility of the researcher is to provide sufficient detail to allow the reader to make such a judgement.

5.6.3.3 Dependability and Confirmability

Dependability and confirmability have been acknowledged as being similar to the concepts of reliability and objectivity, respectively, used in quantitative research (Guba & Lincoln, 1989). These criteria can be assessed through an audit trail, in which the process of the collection, analysis, and interpretation of the data are evaluated by the auditor (Koch, 1994). In the present study, an audit trail was used to establish dependability and confirmability. The audit trail was performed by the research supervisors and the same reviewer who provided peer debriefing. These auditors assisted in the process of data analysis and iterative interpretation of results during all phases of the research through regular meetings. The interview data, results, and interpretation were reviewed and criticised by auditors; there were then several revisions made based on their feedback. The criterion of dependability was also established by providing detailed information in the thesis about the process of data collection, data analysis, and interpretation of the data; this will allow replication of the work by other researchers. Confirmability was further assured by keeping copies of the taped interviews and transcripts so that the interview data are available in an audit trail to verify that the interview results were shaped by interview participants more than the researcher, and thus help establish the trustworthiness of the data.

5.7 Ethical Considerations

Approval was received from Western Sydney University's Human Research Ethics Committee and the Saudi Ministry of Education before commencing this research. All of the participants who participated in the research were volunteers; they were provided with sufficient information about the study to make an informed decision as to whether or not to participate. The participants were given the choice at any time to withdraw from the study without penalty. Prior to each interview, the participants were also informed that they only needed to answer the questions they felt comfortable with. The researcher always ensured that the reasons for her questions and actions were communicated in order to creating a safe and friendly environment. Responses of the teachers were de-identified. The teachers' names, the questionnaires, and the audio tapes were only accessed by the researcher.

5.8 Summary

The present study used a convergent mixed-methods design to collect rich and in-depth data about teachers' self-efficacy and attitudes towards inclusive education kindergarten settings, the factors influencing their self-efficacy and attitudes, and their perception of the barriers to inclusive education in their kindergarten settings. This chapter has provided an explanation of, and justification for using, the convergent mixed-methods approach in this study. It has also detailed and discussed information about the participants in both the quantitative and qualitative phases, the instrumentation used in the study, the quantitative and qualitative data collection and analysis methods, and ethical considerations. The chapter has provided the reader with a comprehensive understanding of the methodological approach and methods used, which form the basis of the results and findings

of the research. The following chapter will present the instrument validity and reliability results.

Chapter 6: Instrument Validity and Reliability Results

6.1 Introduction

This chapter presents the results of the psychometric properties of both the adapted Teacher Efficacy for Inclusive Practices (TEIP) scale (Sharma et al., 2012) and the adapted Opinions Relative to the Integration of Students with Disabilities (ORI) scale (Antonak & Larrivee, 1995). The TEIP and ORI scales used in this study were already established scales and have previously indicated good reliability and validity in both Western and Asian contexts (TEIP scale: Loreman et al., 2014; Park et al., 2016; Savolainen et al., 2012; Sharma et al., 2012; Yada et al., 2018), (ORI scale: Antonak & Larrivee, 1995; Emam & Mohamed, 2011). In Saudi Arabia, the scales have previously been successfully validated and translated into the Arabic language for measuring Saudi primary and secondary school teachers' self-efficacy in inclusive education (Alnahdi, 2019c) and attitudes towards inclusive education (Adhabi, 2018; Al-Ahmadi, 2009; Alhudaithi, 2015; Alqahtani, 2017; Alquraini, 2011). However, these scales had not been utilised with Saudi kindergarten teachers in inclusive kindergarten settings. With the current research being the first study to use them in this context, it was essential to examine whether the Arabic versions of the adapted scales provide a reliable and valid measure for the targeted population in this study.

The results in this chapter are presented in a further five sections. The next section (6.2 Preliminary Analyses) discusses the procedures undertaken to ensure the data were accurate, consistent, useful, and functional before commencing statistical analyses. These analyses included checking for outliers and assessing assumptions of normality. Section 6.3 (Testing for Validity and Reliability of the Adapted Teacher Efficacy for Inclusive Practices [TEIP] Scale) presents results relating to the validity of the TEIP scale using confirmatory

factor analysis (CFA), and the reliability of the scale using Cronbach's alpha. Next, Section 6.4 (Testing for Validity and Reliability of the Adapted Opinions Relative to the Integration of Students with Disabilities [ORI] scale) presents results relating to the validity of the ORI scale using CFA, and the scale's reliability using Cronbach's alpha. The final section (6.5) provides a summary.

6.2 Preliminary Analyses

The main objectives of conducting preliminary analyses of the study data were to eliminate errors and redundancy, ensure accuracy and consistency, and increase data reliability (Hair et al., 2010). Therefore, preliminary analyses were examined before commencing statistical analyses. These preliminary analyses included checking for outliers and assessing assumptions of normality.

6.2.1 Checking for Outliers

An outlier is an observation point with extreme scores on one variable that are distant from other observations (Hair et al., 2010; Pallant, 2013). Many statistical techniques, such as factor analysis, Pearson's correlation coefficients, the t-test, and multiple regression are sensitive to outliers, as the existence of outliers in a dataset can cause problems in these statistical analyses (Pallant, 2013). Therefore, it is important to check for outliers in preliminary analyses.

In the current study, a boxplot was examined to detect outliers in both the TEIP and ORI scales (Pallant, 2013). In SPSS, the outliers appear as little circles with the ID number of the case attached. The outliers are defined as data points that extend from the edge of the box more than 1.5 box lengths. Extreme points (indicated in SPSS with an asterisk, *) are those that are located outside the whiskers of the boxplot more than three box lengths from

the edge of the box. In Figures 6.1 and Figure 6.2 there are no extreme points, but there are 11 outliers in the TEIP scale and 4 outliers in the ORI scale. The scores of these outliers were inspected in the data records to check whether there had been errors in entering the data. This check showed that the outliers' scores were genuine, not errors and they were within the range of that variable's possible scores. To decide whether to remove those outliers or retain them in results for both scales, the 5% trimmed mean and mean values were examined. These provide an indication of how likely outlying cases are to cause a problem. If there is a difference between the trimmed mean and mean values, further investigation of outliers' points is needed. In the present data, the TEIP scale's trimmed mean (3.77) and mean (3.86), and the ORI scale's trimmed mean (3.20) and mean (3.22) values, were very similar and not too different from the rest of the distribution. As a result of this, the researcher decided to retain the outlying cases for both scales in the dataset. Accordingly, the following step was to check another important assumption—the normality of the distributions.

Figure 6.1

Boxplot With Outliers for Teachers' Self-Efficacy (Adapted TEIP Scale)

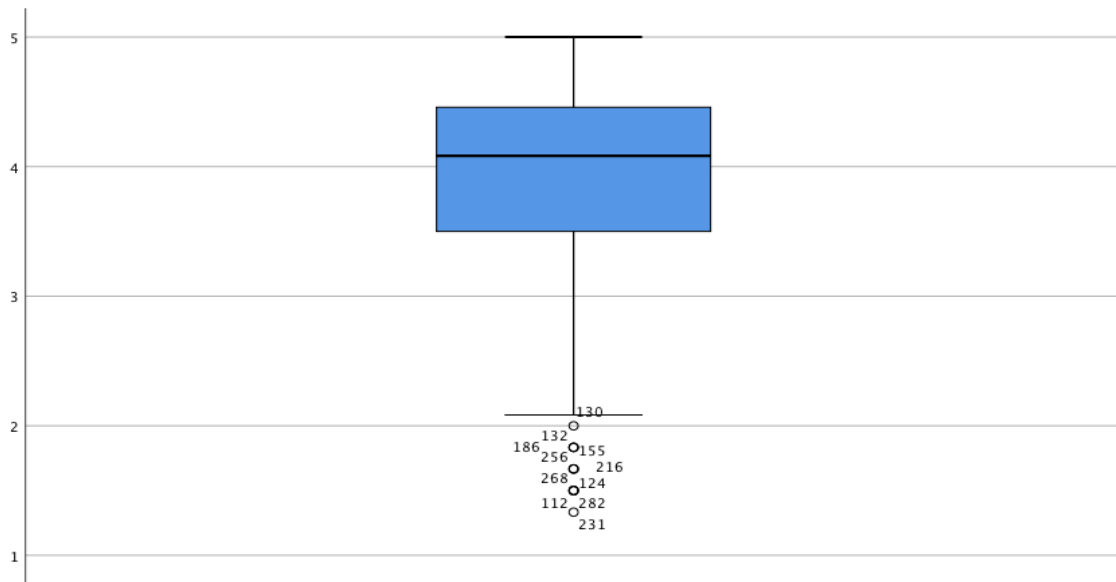
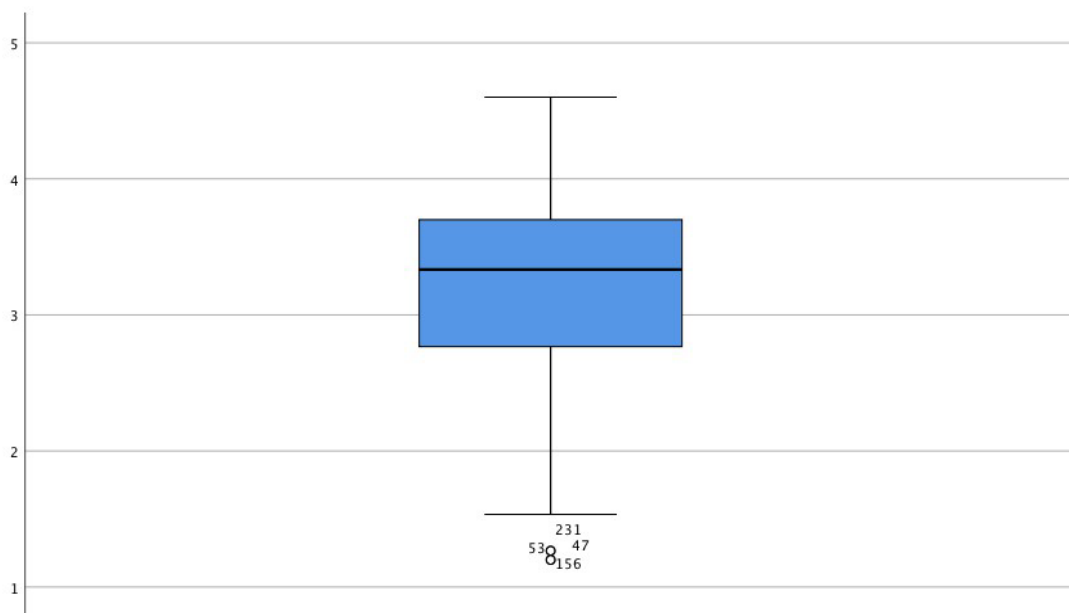

Figure 6.2



6.2.2 Assessing Normality

Examining the assumptions of normality for the dependent variable is an essential step to determine if the data are valid for use in a parametric or non-parametric statistical analysis (Field, 2017). The features of normal distribution are a symmetrical, bell-shaped curve. This curve normally has the majority of the observations concentrated at the centre, with fewer observations at extreme ends (Field, 2017; Pallant, 2013). Examples of distributions which deviate from the rule of normal distribution are those with skew or kurtosis. A skewed distribution usually has the scores concentrated to the left or to the right. Kurtosis is used to describe the sharpness of the peak of a distribution curve (Field, 2017). There are different methods that are used to assess the assumption of normality. The two most commonly used methods to assess normality are the Kolmogorov-Smirnov (K-S) test and z-scores, used to assess skewness and kurtosis. In order to determine that the data is normally distributed, the K-S test should be non-significant ($p > 0.05$), and the z-scores for skewness and kurtosis should have values that range between -1.96 and $+1.96$. However, the K-S test and z-scores are too sensitive with large samples (i.e., sample sizes of 200 or more) (Pallant, 2013). As an alternative to the K-S test and z-scores, Field (2017) recommends inspecting the shape of the distribution of the data by using a histogram.

In the current study, the distributions of continuous variables were tested for normality by inspecting histograms and calculating skewness and kurtosis. Table 6.1 displays the means of the summed scores of continuous variables and their standard deviations. These results demonstrate that the distributions of the variables were not significantly different from normal, as the absolute values of skewness—(TEIP = -1.10),

(ORI = -.65)—and kurtosis—(TEIP = .76), (ORI = .01)—were below the cut-off values of 3.0 and 10.0 respectively. Given this, Kline (2013) suggests that in order to satisfy the assumption of normality the absolute values of skewness and kurtosis should be less than 3.0 and 10.0 respectively. This interpretation was further supported by a visual inspection of Figure 6.3 and Figure 6.4, which show histograms of the distribution of self-efficacy (TEIP) and teachers' attitudes towards inclusion (ORI). The skewness and kurtosis values found and the actual shape of the distribution for each continuous variable, as shown in the histograms, confirm that the current data were normally distributed; therefore, it was appropriate to proceed with parametric statistical analysis.

Figure 6.3

Histogram of the Distribution of Teachers' Self-efficacy (Adapted TEIP Scale)

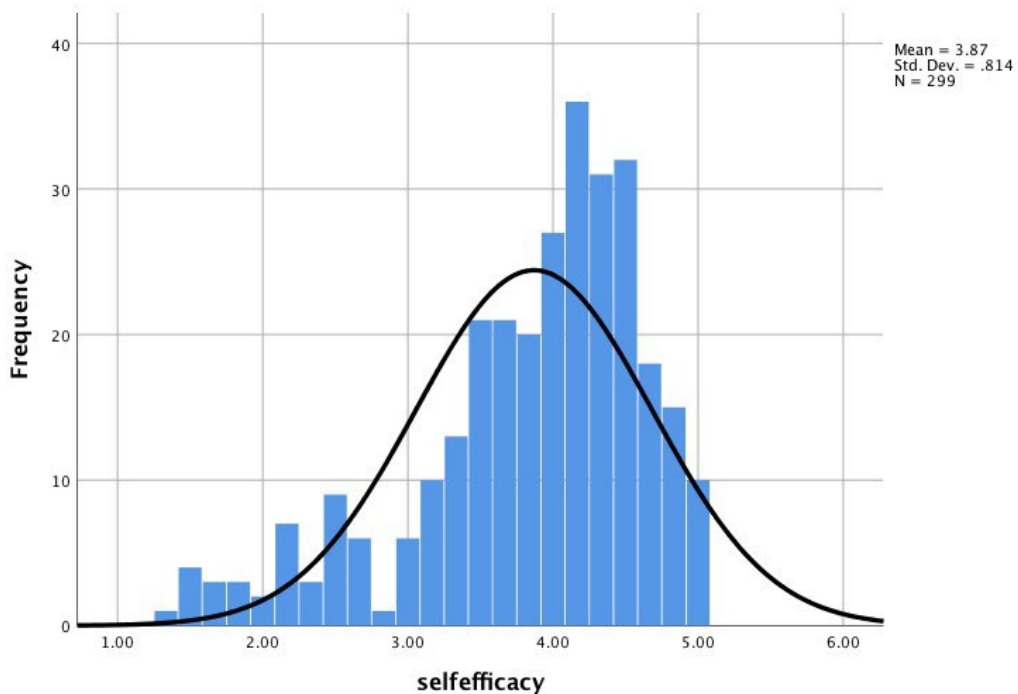

Figure 6.4

Histogram of the Distribution of Teachers' Attitudes (Adapted ORI Scale)

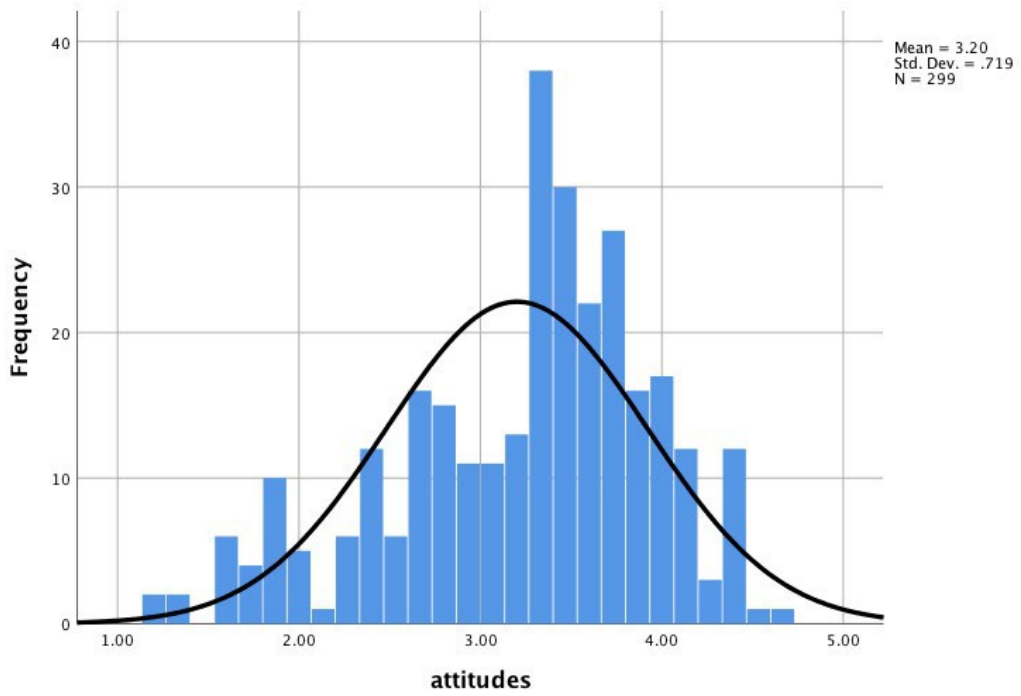

Table 6.1

Test of Normality for the Adapted TEIP and ORI Scales

	N	Kolmogorov-Smirnov Statistic	df	Sig	Mean	Std. deviation	Skewness	Skewness std. error	Kurtosis	Kurtosis std. error
TEIP Scale	299	.129	299	.00	3.86	.814	-1.10	.14	.76	.28
ORI Scale	299		299	.00	3.20	.719	-.65	.14	.01	.28

6.3. Testing for Validity and Reliability of the Adapted Teacher Efficacy for Inclusive Practices (TEIP) Scale

The Teacher Efficacy for Inclusive Practices (TEIP) scale (Sharma et al., 2012) was used to assess Saudi teachers' self-efficacy in inclusive education in kindergarten settings. The TEIP consists of 18 items, which are divided into three factors: (1) Efficacy to use inclusive instructions (EII), (2) Efficacy in collaboration (EC), and (3) Efficacy in managing behaviour (EMB). Each of the three factors comprises six items.

To address the first research question (1.1: How valid is the Teacher Efficacy for Inclusive Practices (TEIP) scale for measuring teachers' self-efficacy in the Saudi inclusive kindergarten context?) confirmatory factor analysis (CFA) was used to test the construct validity of the TEIP scale for the study's participants. To address the second research question (1.2: How reliable is the TEIP scale in the Saudi inclusive kindergarten context?) the items from the TEIP scale were subjected to reliability analysis using Cronbach's Alpha to ensure the internal consistency of the translated version of the TEIP scale. These analyses and their findings in terms of TEIP validity and reliability are presented in the following subsections.

6.3.1 Validity Analysis of the Adapted TEIP Scale

After assessing the assumption of normality and confirming the appropriateness of proceeding with parametric testing, a CFA model of the TEIP scale was estimated to examine whether the measurement indicators had adequate properties to represent the different latent constructs of self-efficacy. As the TEIP scale used in this study is a translated

version of an already established scale, it was considered more important to test the theoretical relationship between the variables through CFA rather than using exploratory factor analysis (EFA).

The results from the CFA, which was conducted using AMOS 21.0 software (2018), revealed the initial and final multiple factor measurement models for the TEIP scale. Figure 6.5 demonstrates the initial multiple factor measurement model for the TEIP scale which includes 18 items divided into three latent constructs: (1) Efficacy to use inclusive instructions (items 5, 6, 10, 14, 15, and 18); (2) Efficacy in collaboration (items 3, 4, 9, 12, 13, and 16); (3) Efficacy in managing behaviour (items 1, 2, 7, 8, 11, and 17). The adequacy of this initial confirmatory multiple factor measurement model was assessed by, firstly, examining standardised loadings from the latent constructs to the observed indicators and, secondly, by examining the different goodness-of-fit indices.

Figure 6.5. presents the factor loadings (regression weights) for the 18 indicators on their latent constructs. Factor loadings on EII range from .61 to .76, those on EC range from .41 to .65, and those on EMB range from .61 to .73. In general, the higher the factor loadings, the more strongly the indicators relate to their associated latent constructs. As a general guideline for this measurement model, factor loading should be at least .5 and preferably .7 or greater (Hair et al., 2010). The latent construct of EC has two factor loadings (for items 3 and 16) that are lower than the minimum threshold of the general guideline for this measurement (Hair et al., 2010). This means that items 3 and 16 in this initial measurement model were not strongly related to their latent construct of efficacy in collaboration.

Figure 6.5

Initial Measurement Model for the Construct of Self-Efficacy (Adapted TEIP Scale)

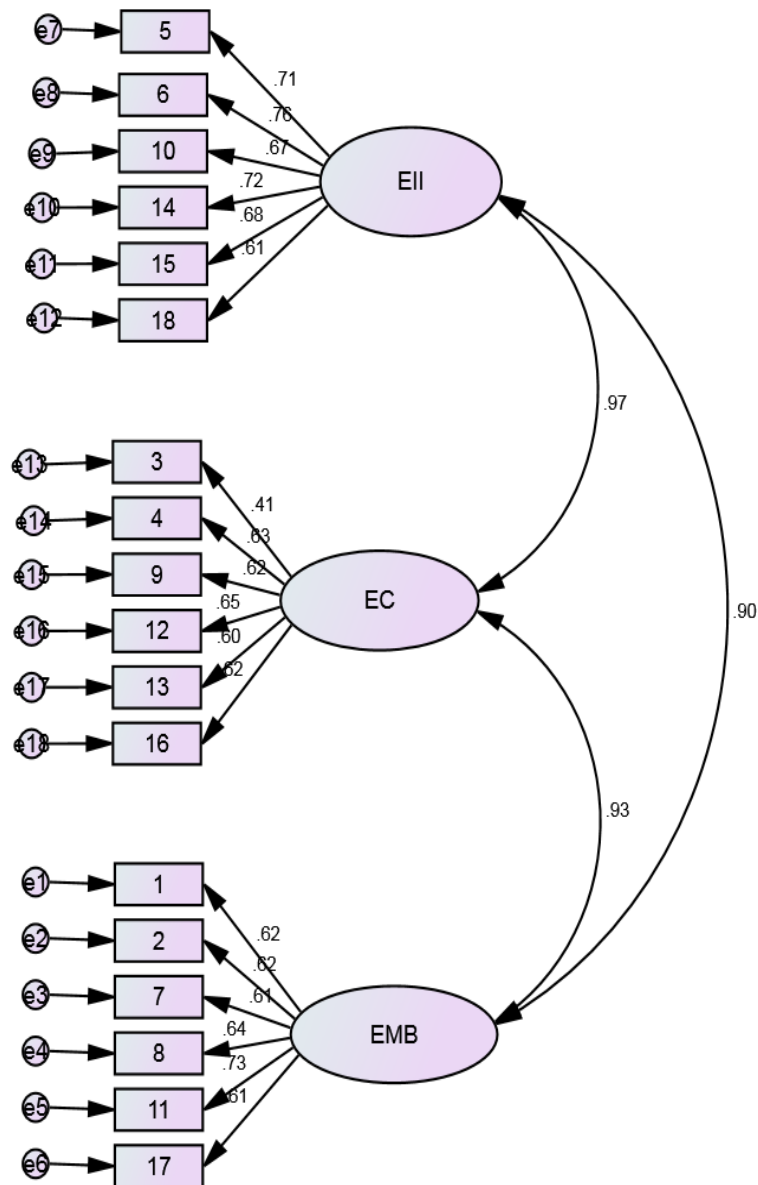

In order to test the adequacy of the initial TEIP multiple factor measurement model, different goodness-of-fit indices have been used. Each one of these indices presents different information about the fitness, or lack of fitness, of a model (see Chapter 5). Table 6.2. presents the goodness-of-fit indices for the initial measurement model for the TEIP scale. The chi-square goodness-of-fit test was 645.10 ($df=132, p=.000$), indicating that the model did not fit the data well. Given the sensitivity of chi-square to large samples, however, alternative goodness-of-fit indices should also be relied on to evaluate the adequacy of the model (Hair et al., 2010). As shown in Table 6.3, the RMSEA value of .114 was higher than the value of $\leq .08$, indicating a poor model fit (Browne & Cudeck, 1993; MacCallum et al., 1996). In addition, the baseline comparison fit indices used—CFI and TLI—had values of less than 0.9 (.79 and .76). Collectively, these goodness-of-fit indices for the TEIP scale indicated a poor fit to the data.

Table 6.2

Goodness-of-Fit Summary for Initial Model of the Adapted TEIP Scale

Model	χ^2	df	χ^2/df	CFI	TLI	RMSEA
Initial Model	645.10***	132	4.88	.79	.76	.114

* $p < .05$. ** $p < .01$. *** $p < .001$.

The CFA results did not confirm the initial multiple factor measurement model. This is because not all goodness-of-fit indices reached acceptable fit thresholds. Therefore, this measurement model, if empirically and theoretically inadequate, required refinement until an adequate fit could be achieved. The adapted TEIP scale refinement process entailed examining the modification indices and factor loadings to determine the poorly fitting items and confirming, at face validity, the suitability of removing these poorly fitting items, which would improve the overall model fit (Byrne, 2016).

6.3.1.1 Modification Indices

Modification indices can be used to provide an indication for measurement model improvement. Modification indices can help inform decisions about which items to freely estimate and which ones will result in a better fit once removed (Byrne, 2016). The modification indices for this analysis were examined by identifying which parameters, if freed, would lead to improving the fit indices of the current measurement model. The limit for modification indices values is discussed by Byrne (2016), as follows: “modification indices [MI] values less than 10.00 are generally considered of little value as freely estimating a formerly fixed parameter on the basis of an MI less than 10.00 will not result in any significant change to overall model fit” (p. 103). This guidance was considered when the current modification indices were examined. Based on the modification indices suggestion made by Byrne, there were many pairs of modification indices which had values more than 10.00 but were not appropriate for covariances because they were not part of the same latent construct. Only one appropriate pair of modification indices for the covariances between the error terms which were part of the same latent construct (Efficacy to use inclusive instructions) and had a value greater than 10.00 were

freed. As shown in Figure 6.6, this modification resulted in the improvement of the final model.

6.3.1.2 Removing Low Factor Loadings

After performing the most appropriate modification indices, any item that did not fit the measurement model due to a low factor loading was removed from the model. Before these items were removed, they were examined for face validity, to confirm the appropriateness of the item's removal (Byrne, 2016). This resulted in six items being removed which had low factor loadings from a different latent construct, with one item removed at a time in order to obtain a better fit. It is recommended that items removed should not exceed 20% of total items in a model. Otherwise, the particular construct itself is deemed to be invalid since it failed the "confirmatory" itself (Awang, 2012). The items removed from the model were: item 15 (I am confident in my ability to get children to work together in pairs or in small groups), and item 18 (I am able to provide an alternate explanation or an example when children with disabilities are confused) from the EII factor; item 3 (I can make parents feel comfortable coming to school) and item 4 (I can assist families in helping their children do well in school) from the EC factor; and item 11(I am able to get children to follow classroom rules) and item 17 (I am confident when dealing with children who are physically aggressive) from the EMB factor. These removed items were deleted from subsequent analyses.

As shown in Figure 6.6, in the final measurement model, the factor loadings (regression weights) for the 12 indicators on the latent constructs EII, EC, and EMB ranged from .61 (item 13) to .73 (item 14), noting that the standardised loadings are estimated

correlations between an item (or indicator) and its associated latent construct. All factor loadings from the latent constructs to the observed indicators were .61 or greater. This suggested that all loadings fell within the acceptable range, which means that the indicators had good correlations with the latent variable (Hair et al., 2010).

Figure 6.6

Final Measurement Model for the Construct of Self-Efficacy (Adapted TEIP Scale)

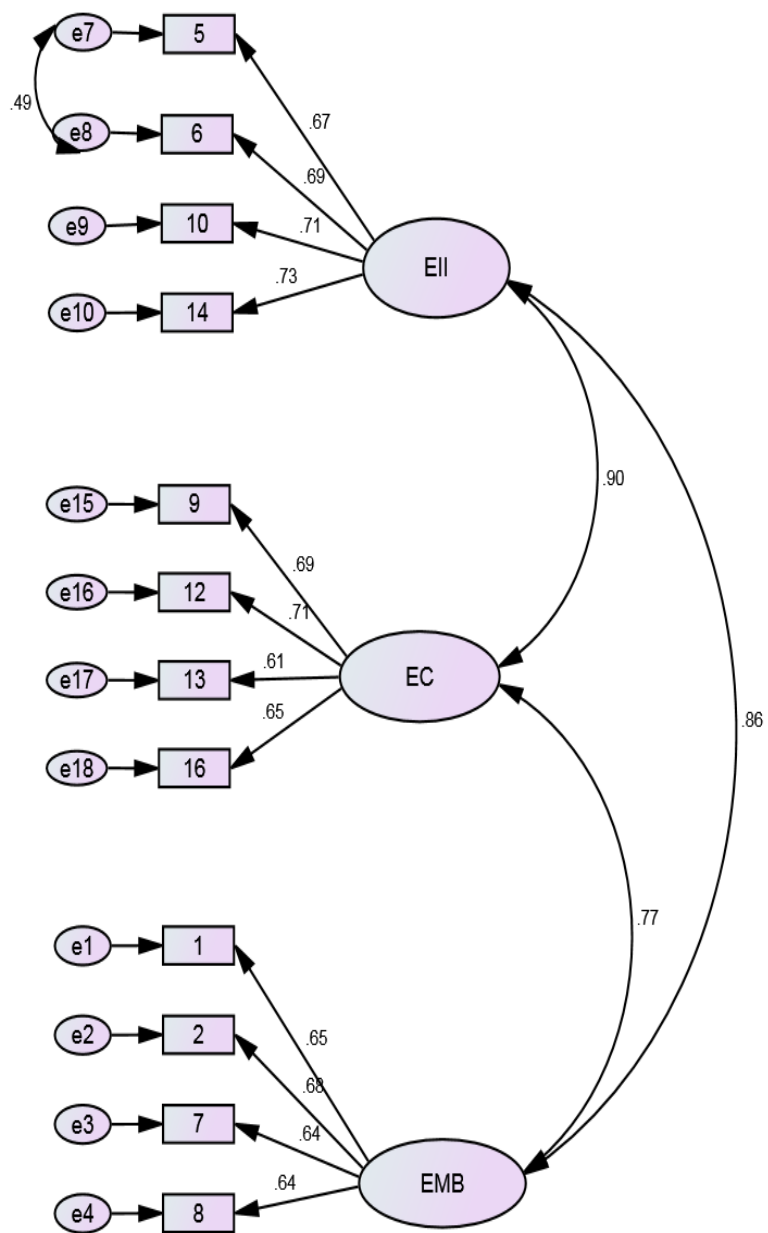

Table 6.3. presents the goodness-of-fit indices which test the adequacy of the final measurement model for the adapted TEIP scale. The chi-square goodness-of-fit test was 132.71 ($df = 50, p = .000$), indicating that the model did not fit the data well. Given the sensitivity of chi-square to large samples, however, alternative goodness-of-fit indices should also be relied on to evaluate the adequacy of the model (Hair et al., 2010). As shown in Table 6.3, the RMSEA value of .075 was less than the value of $\leq .08$, indicating an acceptable model fit (Browne & Cudeck, 1993; MacCallum et al., 1996). The baseline comparison fit indices of CFI and TLI, moreover, were close to or higher than 0.9 (.94 and .92). Collectively, these goodness-of-fit indices suggested that the measurement model of the adapted TEIP scale fits the data reasonably well, and that all 12 items were significant reflective indicators of their associated constructs of self-efficacy (TEIP).

Table 6.3

Goodness-of-Fit Summary for the Final Model of the Adapted TEIP Scale

Model	χ^2	df	χ^2/df	CFI	TLI	RMSEA
Final model	132.71***	50	2.65	.94	.92	.075

* $p < .05$. ** $p < .01$. *** $p < .000$

In order for the current translated version of the adapted TEIP scale to provide psychometrically valid measurement for measuring Saudi kindergarten teachers' self-efficacy in inclusive education, the two subtypes of construct validity—convergent validity and discriminant validity—were examined. Convergent validity and discriminant validity of the items and their latent constructs on the adapted TEIP scale were statistically measured through the assessment of correlation matrices (see Table 6.4).

Table 6.4
Inter-item Correlations for the Adapted TEIP Scale

	(5)	(6)	(10)	(14)	(9)	(12)	(13)	(16)	(1)	(2)	(7)	(8)
5 EII	-											
6 EII	.727	-										
10 EII	.454	.494	-									
14 EII	.493	.506	.518	-								
9 EC	.375	.403	.439	.463	-							
12 EC	.432	.465	.400	.466	.485	-						
13 EC	.361	.370	.386	.329	.489	.522	-					
16 EC	.367	.340	.426	.398	.470	.448	.495	-				
1 EMB	.230	.435	.423	.332	.262	.246	.209	.305	-			
2 EMB	.337	.392	.352	.363	.302	.339	.231	.408	.446	-		
7 EMB	.302	.349	.377	.404	.379	.369	.204	.350	.452	.470	-	
8 EMB	.337	.333	.397	.368	.377	.339	.390	.441	.508	.403	.423	-

According to DeVellis (2012), there are no objective cut-off numerical values that determine how strong the correlations should be between items in a scale to define convergent validity. Therefore, convergent validity exists when the items of the same latent construct are more highly correlated with each other than with items from across other constructs. As shown in Table 6.4, items on the adapted TEIP scale show higher correlations with themselves than with other items, thus demonstrating convergent validity. Furthermore, the inter-item correlations among items that were intended to measure distinct latent constructs were low, indicating discriminant validity (Kline, 1998, 2013). Discriminant validity was also examined among the three latent constructs of the adapted TEIP scale and results indicated that discriminant validity existed between the three latent constructs within the adapted TEIP scale ($r < .90$; Kline, 1998, p. 72) and the other constructs from which they were distinct (see Table 6.5). This confirms that the three adapted TEIP factors were measuring distinct latent constructs. Hence, the results of the convergent and

discriminant validity provided support for the construct validity of the refined, translated version of the adapted TEIP scale and answered research question 1.1.

Table 6.5
Correlations Among the Three Latent Constructs of the Adapted TEIP Scale

TEIP factor	1	2	3
Inclusive instruction	1		
Collaboration	.682	1	
Managing behaviour	.658	.584	1

6.3.2. Reliability Analysis of the Adapted TEIP Scale

After confirming the construct validity of the adapted TEIP scale, it was essential to test for the internal consistency of this refined (reduced to 12 items) and validated scale. Reliability was determined using Cronbach’s alpha. Thus, this section addresses research question 1.2: How reliable is the TEIP scale in the Saudi inclusive kindergarten context? Field (2017) defined reliability as the ability of a questionnaire to yield similar findings when repeated under the same or similar conditions. Classical test theory’s reliability coefficients remain widely used in behavioural and social research (Field, 2017). Each provides an index of measurement consistency ranging from 0 to 1.00, which can be interpreted as the proportion of observed-score variance attributable to true scores (stable or non-random individual differences). Coefficients at or above 0.70 are often considered sufficiently reliable for making decisions about individuals based on their observed scores, although a higher value, perhaps 0.90, is preferred if the decisions have significant consequences (Field, 2017; Kline, 2013). The Cronbach’s alpha values for the three factors and the total adapted TEIP scale are shown in Table 6.6.

Table 6.6*Cronbach's Alpha Values for the Adapted TEIP Scale*

TEIP scale	Number of items (N)	Cronbach's alpha
Instructions	4	.811
Collaboration	4	.763
Managing behaviour	4	.747
TEIP total	12	.891

The reliability coefficients of the total TEIP scale, and its three factors—the Efficacy to use inclusive instructions factor, Efficacy in collaboration factor, and Efficacy in managing behaviour factor—were .89, .81, .76, and .74, respectively, with all Cronbach's alpha values higher than .7, indicating the high internal consistency of the total adapted TEIP scale and its three factors (Field, 2017; Kline, 2013). Hence, this result indicated that the adapted TEIP scale was reliable in the Saudi kindergarten inclusive education context and these findings answered research question 1.2.

6.4. Testing for Validity and Reliability of the Adapted Opinions Relative to the Integration of Students with Disabilities (ORI) Scale

The Opinions Relative to the Integration of Students with Disabilities (ORI) scale was adapted and used to investigate teachers' attitudes towards inclusive education in Saudi kindergarten settings. The adapted ORI consists of 25 items, which were divided into four factors, namely: Benefits of integration, which included 8 items; Integrated classroom management, which included 10 items; Perceived ability to teach children with disabilities, which included 3 items; and Special versus integrated general education teachers, which included 4 items.

To address research question 1.3 (How valid is the Opinions Relative to the Integration of Students with Disabilities (ORI) scale for measuring teachers' attitudes in the Saudi inclusive kindergarten context?), confirmatory factor analysis (CFA) was used to test the construct validity of the translated version of the adapted ORI scale for the participants in this study. Furthermore, to address research question 1.4 (How reliable is the ORI scale in the Saudi inclusive kindergarten context?), the items from ORI scale were subjected to reliability tests using Cronbach's alpha to ensure the internal consistency of the translated and adapted version of the ORI scale. The process of conducting these analyses, and the findings of these measures for the adapted ORI are presented in following subsection.

6.4.1 Validity Analysis of the Adapted ORI Scale

After assessing the assumption of normality and thus confirming the appropriateness of proceeding with parametric testing, the CFA was used to assess whether the measurement indicators had adequate properties to represent the different latent constructs of the adapted ORI scale. The results from the CFA identified the initial and final multiple factor measurement models for the construct of adapted ORI scale. Figure 6.7 demonstrates the initial measurement model for the adapted ORI scale, which included 25 items divided into four latent constructs: (1) Benefits of integration (BI; items 3, 7, 11, 14, 17, 20, 21, and 24); (2) Integrated classroom management (ICM; items 1, 4, 6, 9, 12, 15, 16, 18, 22, and 25); (3) Perceived ability to teach children with disabilities (PA; items 2, 10, and 19); and (4) Special versus integrated general education teachers (SVG; items 5, 8, 13, and 23).

Figure 6.7 presents the factor loadings (regression weights) for the 25 indicators on their latent constructs. Factor loadings ranged from $-.39$ to $-.69$ for BI, from $.35$ to $.67$ for ICM, from $-.27$ to $.47$ for PA, and from $.03$ to $.78$ for SVG. Considering the guidelines for assessing significant factor loadings based on sample size, factor loadings for this measurement model should be at least $.35$, given the sample size of 299 (Hair et al., 2010). This suggests that not all loadings fell within the acceptable range, which means that some indicators had poor correlations with the latent variable.

Figure 6.7

Initial Measurement Model for the Construct of Attitudes (Adapted ORI Scale)

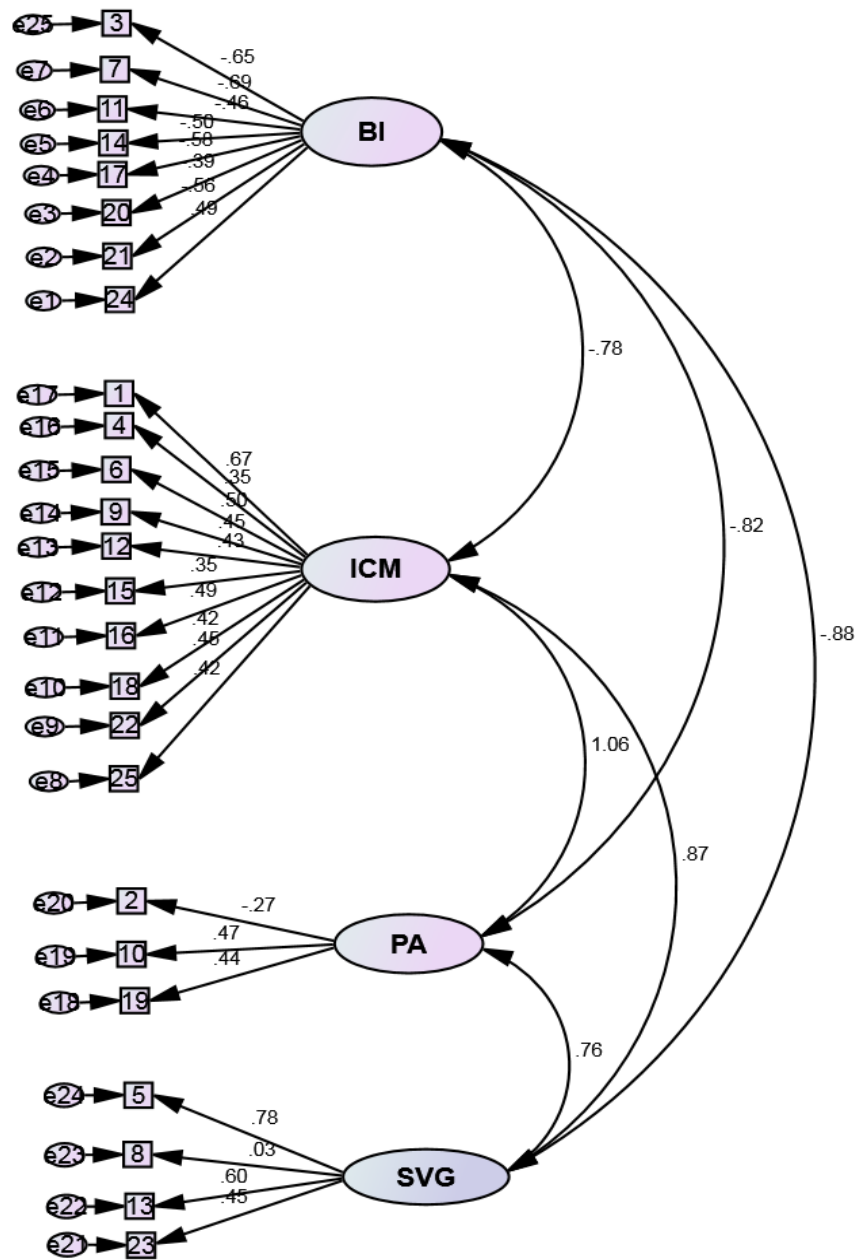

In order to test the adequacy of the initial confirmatory multiple factor measurement model for the adapted ORI scale, different goodness-of-fit indices were used. Table 6.7 presents the goodness-of-fit indices of the initial measurement model for the adapted ORI scale. The chi-square goodness-of-fit test was 968.17 ($df = 269$, $p = .000$), indicating that the model did not fit the data well. Given the sensitivity of chi-square to large samples, however, alternative goodness-of-fit indices should also be relied on to evaluate the adequacy of the model (Hair et al., 2010). As shown in Table 6.7, the RMSEA value of .093 was slightly higher than the value of $\leq .08$, indicating a poor model fit (Browne & Cudeck, 1993; MacCallum et al., 1996). The baseline comparison fit indices of CFI and TLI, moreover, were less than 0.9 (.65 and .61, respectively). Collectively, these goodness-of-fit indices for the initial confirmatory multiple factor measurement model for the adapted ORI scale indicated a poor fit, and that all 25 items were not significant reflective indicators of the latent constructs of the adapted ORI scale.

Table 6.7
Goodness-of-Fit Summary for Initial Model of the Adapted ORI Scale

Model	χ^2	df	χ^2/df	CFI	TLI	RMSEA
Default	968.17***	269	3.59	.65	.61	.093

* $p < .05$. ** $p < .01$. *** $p < .001$

As the CFA analysis did not confirm the initial multiple factor measurement model because not all goodness-of-fit indices suggested the model fit was acceptable, a further refinement process was required for the adapted ORI scale. This process entailed examining the modification indices and factor loadings to determine the poorly fitting items and confirming, at face validity, the suitability of removing these items. This process was undertaken to improve the overall model fit (Byrne, 2016).

6.4.1.2 Modification Indices

Based on the modification indices suggestions, there were many pairs of modification indices which had values of more than 10.00 but were not appropriate for covariances because they were not part of the same latent construct. Only three pairs of modifications for the covariances between the error terms were part of the same latent constructs (BI and ICM) and had a value greater than 10.00. Thus, as shown in Figure 6.8, this modification resulted in improvement of the final model.

6.4.1.3 Removing Low Factor Loadings

To obtain further improvement of the model fit after performing the most appropriate modification indices, any item that did not fit the measurement model due to low factor loadings were removed from the model. This resulted in removing the factor “Perceived ability to teach children with disabilities,” which had very low factor loadings and measured the same concept of teachers’ self-efficacy. This factor included three items: item 2 (Inclusion of children with disabilities will necessitate extensive retraining of general classroom teachers), item10 (General classroom teachers have the abilities necessary to work with children with disabilities), and item 19 (General classroom teachers have

sufficient training to teach children with disabilities). In addition, there were six other items with low factor loadings removed from different latent constructs, one item at a time, in order to obtain a better fit (20, 21, 24 from BI; 4 and 12 from ICM; and 8 from SVG). In detail, these items were, for the BI factor: item 20 (Inclusion will likely have a negative effect on the emotional development of the child with a disability), item 21 (Children with disabilities should be given every opportunity to function in the inclusive classroom when possible), and item 24 (Special classrooms can have beneficial effects on the social and emotional development of the child with a disability). For the ICM factor, they were: item 4 (It is likely that the child with disability will exhibit behaviour problems in an inclusive classroom) and item 12 (The behaviour of children with disabilities will set a bad example for students without disabilities). From the SVG factor, the removed item was: item 8 (Inclusion of children with disabilities will require significant changes in inclusive classroom procedures). These removed items were removed from subsequent analyses.

As shown in Figure 6.8, in the final measurement model standardised loadings for the 15 indicators on the latent constructs—BI, ICM, and SVG—range from .33 (item 15) to .78 (item 5). In this model, all values of the standardised loadings, except the factor loading of .33 for item 15 from the ICM factor, were more than the cut-off value of .35, indicating that all indicators are related to their associated construct (Hair et al., 2010).

Figure 6.8

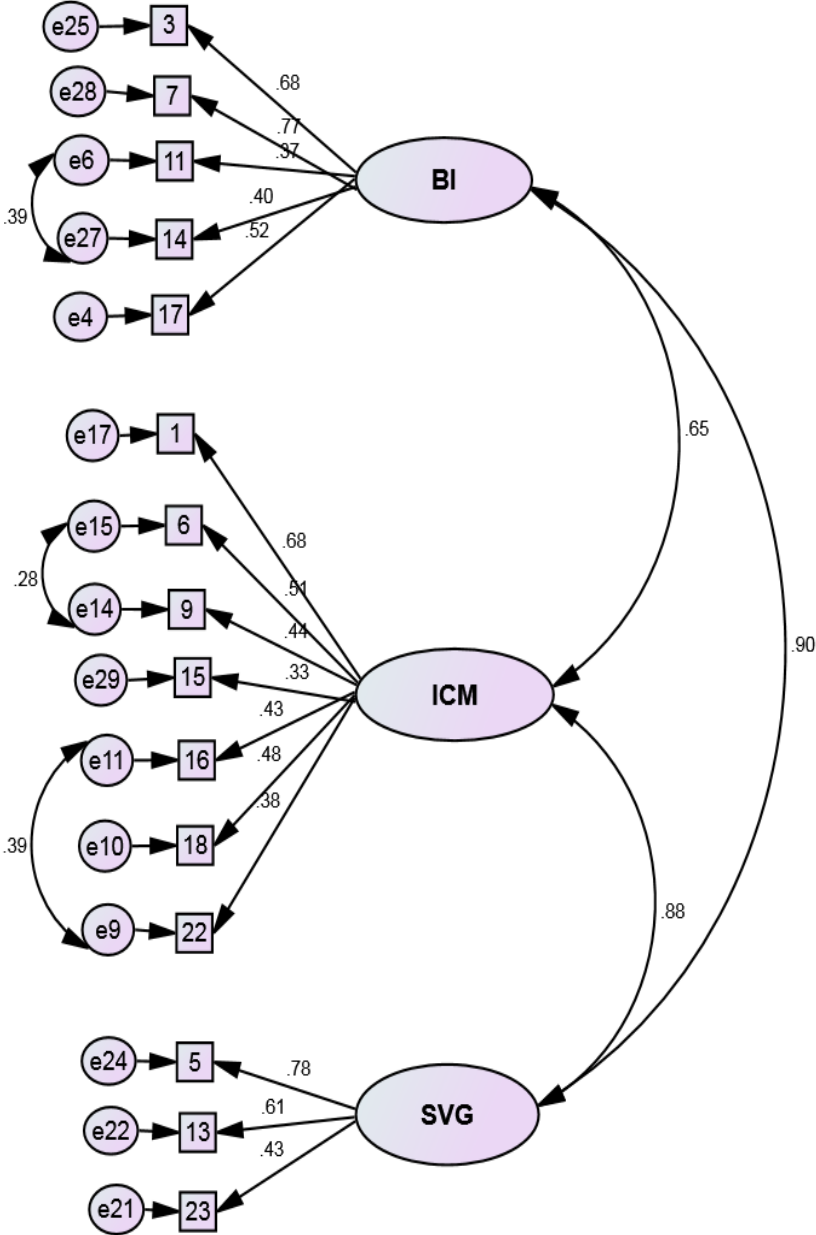

Table 6.8 presents the goodness-of-fit indices, which test the adequacy of the final confirmatory multiple factor measurement model for the adapted ORI scale. The chi-square goodness-of-fit test was 194.83 ($df = 84, p = .000$), indicating that the model did not fit the data well. However, the model χ^2 will almost always be statistically significant with large sample sizes even if the model has a good fit to the data (Byrne, 2016; Hair et al., 2010). Therefore, alternative goodness-of-fit indices were relied on to evaluate the adequacy of the model (Hair et al., 2010). As shown in Table 6.8, the RMSEA value of 0.06 was below the recommended value of $\leq .08$ indicated an acceptable model fit (Browne & Cudeck, 1993; MacCallum et al., 1996). The baseline comparisons fit indices of CFI and TLI, moreover, were close to or higher than 0.9 (.93 and .90) (see Table 6.8). Collectively, these goodness-of-fit indices indicated that the final measurement model fit the data reasonably and that all 15 items were significant reflective indicators of their respective construct of teachers' attitudes.

Table 6.8

Goodness-of-Fit Summary for Final Model of the Adapted ORI Scale

Model	χ^2	df	χ^2 / df	CFI	TLI	RMSEA
Default	194.38***	84	2.31	.93	.90	.067

* $p < .05$. ** $p < .01$. *** $p < .000$.

In order for the current translated and refined version of the adapted ORI scale (with 15 items) to provide psychometrically valid measurement for measuring Saudi kindergarten teachers' attitudes toward inclusive education, the two subtypes of construct validity—

convergent validity and discriminant validity—were examined. The convergent validity and discriminant validity of the items and their latent constructs on the adapted ORI scale were statistically measured through the assessment of correlation matrices (see Table 6.9).

Table 6.9
Inter-item Correlations for the Adapted ORI Scale

	(3)	(7)	(11)	(14)	(17)	(1)	(6)	(9)	(5)	(16)	(18)	(22)	(5)	(13)	(23)
BI (3)	-														
BI (7)	.541	-													
BII (1)	.247	.284	-												
BII (4)	.349	.242	.476	-											
BII (7)	.325	.360	.337	.320	-										
ICM (1)	.207	.214	.168	.262	.254	-									
ICM (6)	.221	.230	.226	.173	.234	.349	-								
ICM (9)	.176	.116	.206	.200	.208	.248	.445	-							
ICM (15)	.162	.173	.080	.108	.105	.181	.136	.178	-						
ICM (16)	.258	.233	.095	.154	.175	.390	.156	.164	.240	-					
ICM (18)	.112	.228	.047	.054	.175	.253	.345	.295	.163	.168	-				
ICM (22)	.208	.207	.069	.046	.276	.294	.239	.211	.136	.486	.110	-			
SVG (5)	.275	.210	.232	.229	.356	.464	.311	.298	.244	.215	.334	.203	-		
SVG (13)	.389	.225	.037	.216	.329	.425	.221	.200	.142	.143	.306	.207	.479	-	
SVG (23)	.154	.214	.225	.190	.197	.315	.246	.345	.150	.229	.279	.166	.350	.234	-

Table 6.9 shows that items on the refined ORI scale present higher correlations among themselves, indicating convergent validity. Furthermore, the inter-item correlations among items that were intended to measure distinct latent constructs were low, indicating discriminant validity (Kline, 1998, 2013).

Examination of the correlation values indicates that the three latent constructs within the adapted ORI scale were discriminant ($r < .90$; Kline, 1998, p. 72) with other constructs from which they were distinct. This confirms that the ORI factors were measuring distinct latent constructs. Hence, the results of the convergent and discriminant validity testing provided support for the construct validity of the translated and adapted ORI scale (with 15 items); these findings answer research question 1.3.

Table 6.10

Correlations Among the Three Latent Constructs of the Adapted ORI Scale

ORI factor	1	2	3
Benefits of integration	1		
Integrated classroom management	.428	1	
Special versus integrated general education teachers	.539	.564	1

6.4.2 Reliability Analysis of the Adapted ORI Scale

After confirming the construct validity of the refined ORI scale, it is essential to test the internal consistency reliability of this refined (reduced to 15 items) and validated scale to obtain a good instrument. The reliability test was conducted by using Cronbach's alpha. Thus, this section addresses to the fourth research question (1.4): How reliable is the ORI scale in the Saudi inclusive kindergarten context? Internal reliability was examined for the total ORI scale and its three factors separately. As shown in Table 6.11, the reliability coefficients for the Benefits of integration factor, Integrated classroom management factor, Special versus integrated general education teachers factor, and the total ORI scale were .72, .68, .62, and .82, respectively. These results indicate acceptable internal consistency of the overall ORI scale, with a Cronbach's alpha value higher than .7 (Field, 2017; Kline, 2013). Hence, this result indicated that the adapted ORI scale is reliable in the Saudi inclusive kindergarten context and answered research question 1.4.

Table 6.11

Cronbach's Alpha Values for the Adapted ORI Scale

ORI scale	Number of items	Cronbach's alpha
Benefits of integration	5	.722
Integrated classroom management	7	.687
Special versus integrated general education Teachers	3	.620
ORI total	15	.826

6.5 Summary

This chapter has sought to satisfy research aim 1 and, alongside this, has sought to answer research questions 1.1, 1.2, 1.3, and 1.4. Data analyses began with preliminary analyses which confirmed that the data were normally distributed and thus it was appropriate to proceed with parametric statistical analysis. The findings of the confirmatory factor analysis and correlation analysis supported the construct validity of the adapted and translated versions of the TEIP and ORI scales to measure teachers' self-efficacy and attitudes towards inclusive education in Saudi kindergarten settings. Following the CFA analysis, the adapted TEIP scale now consisted of 12 items across the three latent constructs and the adapted ORI scale consisted of 15 items across the three latent constructs. After confirming the construct validity of the adapted TEIP and ORI scales, reliability analysis was conducted, which indicated that the refined TEIP and ORI scales are reliable in the Saudi kindergarten inclusive education context.

Chapter 7: Results of the Questionnaire Analyses

7.1 Introduction

This chapter presents the results of the questionnaire data analysis to address the second, third and fourth research aims. Section 7.2 presents results related to teachers' self-efficacy and attitudes towards inclusive education (Aim 2), if these vary between general and special education teachers, and the relationship between teachers' self-efficacy and attitudes. Section 7.3 presents results concerning the influence of **teacher-related factors** on teachers' self-efficacy and attitudes (Aim 3). Section 7.4 presents results concerning the influence of **child-related factors** on teachers' self-efficacy and attitudes and Section 7.5 presents results concerning the influence of **context-related factors** on teachers' self-efficacy and attitudes (Aim 3). Section 7.6 presents results related to teachers' perceptions of barriers to inclusive education in Saudi kindergarten settings (Aim 4). Section 7.7 provides a summary of the quantitative data from the questionnaires.

7.2 Teachers' Self-Efficacy and Attitudes Towards Inclusive Education

7.2.1 Examining Kindergarten Teachers' Self-Efficacy in Inclusive Education

Research Question 2.1 What are Saudi kindergarten teachers' levels of self-efficacy towards inclusive education as measured by Teacher Efficacy for Inclusive Practices (TEIP)?

Research question 2.1 was analysed by examining the means and standard deviations for self-efficacy. The adapted TEIP scale consists of 12 items which, based on the confirmatory factor analysis described in the previous chapter, are organised into three factors: (a) Efficacy to use inclusive instructions (EII); (b) Efficacy in collaboration (EC); and (c) Efficacy in managing behaviour (EMB). Responses to the 5-point Likert-type scale were: strongly agree = 5, agree = 4, neutral = 3, disagree = 2, and strongly disagree = 1. Table 7.1 presents the means and standard deviations of the kindergarten teachers' scores on EII ($M = 3.91, SD = .95$), EC ($M = 3.90, SD = .90$), and EMB ($M = 3.78, SD = .93$), and for the overall self-efficacy of Saudi kindergarten teachers towards including children with disabilities in inclusive classrooms ($M = 3.86, SD = .81$).

Based on these values, Saudi kindergarten teachers generally held somewhat positive self-efficacy in inclusive education, since the overall mean of TEIP scale values was 3.86, which is close to 4 (agree). The Saudi kindergarten teachers' level of self-efficacy in using inclusive instruction was the highest of the three TEIP factors ($M = 3.91, SD = .95$), while they had lower relative self-efficacy in managing children' behaviour in the inclusive classroom ($M = 3.78, SD = .93$) but still rated as somewhat positive by remaining above the average point (3) of the 5-point Likert-type scale.

Table 7.1*Means and Standard Deviations of Teachers' Self-Efficacy Towards Inclusive Education*

TEIP Scale	<i>M</i>	<i>SD</i>
Efficacy to use inclusive instructions (EII)	3.91	.95
Efficacy in collaboration (EC)	3.90	.90
Efficacy in managing behaviour (EMB)	3.78	.93
Total TEIP scale	3.86	.81

*Note. N = 299.***7.2.2 Examining Kindergarten Teachers' Attitudes Towards Inclusive Education**

Research Question 2.2 What are Saudi kindergarten teachers' attitudes towards inclusive education settings as measured by Opinions Relative to the Integration of Students with Disabilities (ORI)?

To answer this question, means and standard deviations were analysed. The adapted ORI scale consists of 15 items which, based on the confirmatory factor analysis in the previous section, are divided into three factors: (a) Benefits of integration (BI); (b) Integrated classroom management (ICM); and (c) Special versus integrated general education (SVG). The responses to the 5-point Likert-type scale were: strongly agree = 5, agree = 4, neutral = 3, disagree = 2, and strongly disagree = 1.

Table 7.2 presents the means and standard deviations for the BI factor ($M = 3.85$, $SD = .90$), the ICM factor ($M = 2.74$, $SD = .77$), the SVG factor ($M = 3.17$, $SD = 1.04$), and for Saudi kindergarten teachers' overall attitudes towards including children with disabilities in inclusive classrooms (ORI total scale; $M = 3.20$, $SD = .71$). Based on these values, Saudi kindergarten teachers held generally neutral attitudes towards inclusive

education, since the overall mean of the ORI scale values was 3.20, which is close to 3 (neutral) on a 5-point Likert-type scale. The Saudi kindergarten teachers' attitude level for the BII factor was the highest for any of the three ORI factors ($M = 3.85$, $SD = .90$), while attitude levels were relatively lower for the ICM factor than other ORI factors ($M = 2.74$, $SD = .77$).

Table 7.2

Means and Standard Deviations of Teachers' Attitudes Towards Inclusive Education

ORI Scale	<i>M</i>	<i>SD</i>
Benefits of integration (BI)	3.85	.90
Integrated classroom management (ICM)	2.74	.77
Special vs. integrated general education (SVG)	3.17	1.04
Total ORI scale	3.20	.71

Note. $N = 299$.

7.2.3 Examining the Differences in the Self-Efficacy Between General and Special

Education Teachers

Research Question 2.3 What is the difference between Saudi general education and special education teachers' self-efficacy in inclusive education in kindergarten settings?

To answer this question, a t-test of independent means was used to measure significant differences in Saudi kindergarten teachers' self-efficacy in inclusive education based on their current teaching position in kindergarten settings. In order to determine whether there were equal variances between the independent groups a test of homogeneity of variance was conducted using Levene's Test (Levene, 1960) (see Table 7.3). Results for the total TEIP scale were $F = 23.353, p = .000$ and the three TEIP factor results were $F = 35.876, p = .000$; $F = 21.375, p = .000$; and $F = 8.108, p = .005$, respectively. As a result, the samples did not have equal variances since the significance level of Levene's Test was less than 0.05, so the assumption of homogeneity of variance was not met. In this situation, the "equal variances not assumed" value is used, which is a more conservative estimate.

Table 7.3 also presents the results of the independent t-test showing the differences in teachers' self-efficacy between general and special education teachers. Results in Table 7.3 reveal that there was a significant difference between general and special education teachers' level of self-efficacy in using inclusive instruction ($t = 9.16, p < .000$, two-tailed); collaboration ($t = 7.38, p < .000$, two-tailed); and managing behaviour ($t = 4.61, p < .000$, two-tailed); and in their total level of self-efficacy ($t = 7.38, p < .000$, two-tailed).

These findings attest to special education teachers having higher levels of self-efficacy across the total TEIP score ($M = 4.37, SD = .42$) and its three factors of inclusive instruction ($M = 4.52, SD = .40$); collaboration ($M = 4.42, SD = .49$); and managing behaviour ($M = 4.18, SD = .72$) than general education teachers. However, general education teachers still demonstrate somewhat positive self-efficacy across the total TEIP scale ($M = 3.73, SD = .83$) and its three factors of inclusive instruction ($M = 3.75, SD = .98$), collaboration ($M = 3.77, SD = .94$), and managing behaviour ($M = 3.68, SD = .96$).

Table 7.3*T-Test results for General and Special Education Teachers' Self-Efficacy*

		Levene's Test for equality of variances				T-test for equality of means		
		<i>F</i>	Sig	<i>t</i>	<i>df</i>	Sig(2-tailed)	Mean Differences	Std. Error Differences
Inclusive instruction	Equal variances assumed	35.876	.000***	5.938	297	.000***	.75979	.12796
	Equal variances not assumed			9.166	249.27	.000***	.75979	.08289
Collaboration	Equal variances assumed	21.375	.000***	5.260	297	.000***	.64839	.12327
	Equal variances not assumed			7.389	191.484	.000***	.64839	.08775
Managing behaviour	Equal variances assumed	8.108	.005***	3.909	297	.000***	.50854	.13008
	Equal variances not assumed			4.614	127.666	.000***	.50854	.11023
TEIP (total)	Equal variances assumed	23.353	.000***	5.834	297	.000***	.63891	.10952
	Equal variances not assumed			8.359	201.985	.000***	.63891	.07643

*Note. N = 299.***p < .05. **p < .01. ***p < .001.*

7.2.4 Examining Differences in the Attitudes of General and Special Education

Teachers

Research Question 2.4. What is the difference between Saudi general education and special education teachers' attitudes towards inclusive education in kindergarten settings?

To answer this question a t-test of independent means was used to measure significant differences in Saudi kindergarten teachers' attitudes towards inclusive education based on their current teaching position in kindergarten settings. In order to determine whether there were equal variances between the independent groups a test of homogeneity of variance was conducted with Levene's Test. Results from this test (shown in Table 7.4) indicated values for the total ORI scale of $F = 13.125, p = .000$; the ORI factor values were $F = 49.469, p = .000$; $F = 3.612, p = .058$; and $F = 3.562, p = .056$, respectively. Given these results, the samples did not have equal variances since the significance level of Levene's Test was less than 0.05, so the assumption of homogeneity of variance was not met. In this situation, the "equal variances not assumed" value is used, which is a more conservative estimate.

Table 7.4 also presents the results of the independent t-test showing the differences in attitudes between special and general education teachers. Results in Table 7.4 reveal that there was a significant difference between general and special education teachers' attitudes for the BI ($t = 8.14, p < .000$, two-tailed); ICM ($t = 3.51, p < .001$, two-tailed); and SVG ($t = -3.80, p < .000$, two-tailed) factors; and in their total attitudes ($t = 6.34, p < .000$, two-tailed). These findings attest to special teachers having more positive attitudes across the total ORI score ($M = 3.60, SD = .46$) and its three factors—BI ($M = 4.37, SD = .39$), ICM ($M = 3.04, SD = .67$), and SVG ($M = 3.63, SD = 1.03$)—than general education teachers. Values for the general education teachers for the total ORI scale were $M=3.09, SD=.73$; for

the three factors they were $M=3.71$, $SD = .95$; $M= 2.66$, $SD = .78$; and $M=3.05$, $SD = 1.01$, respectively.

Table 7.4

T-Test Results for General and Special Education Teachers' Attitudes

		Levene's Test for Equality of Variances				T-test for Equality of Means		
		<i>F</i>	Sig	<i>t</i>	<i>df</i>	Sig (2-tailed)	Mean Differences	Std. Error Differences
Benefits of integration	Equal variances assumed	49.469	.000***	5.273	297	.000***	.65130	.12353
	Equal variances not assumed			8.148	246.959	.000***	.65130	.07994
Classroom management	Equal variances assumed	3.612	.058*	3.222	297	.001***	.34971	.10854
	Equal variances not assumed			3.519	111.208	.001***	.34971	.09938
Special vs. integrated general education	Equal variances assumed	3.562	.056*	3.850	297	.000***	.55831	.14501
	Equal variances not assumed			3.807	96.244	.000***	.55831	.14666
ORI (total)	Equal variances assumed	13.125	.000***	5.017	297	.000***	.49196	.09806
	Equal variances not assumed			6.343	147.533	.000***	.49196	.07756

Note. $N = 299$.

* $p < .05$. ** $p < .01$. *** $p < .001$.

7.2.5 Examining the Relationship between Teachers' Self-Efficacy and Attitudes

Research Question 2.5. What is the relationship between Saudi teachers' self-efficacy and attitudes towards inclusive education in kindergarten settings?

To examine the relationship between teachers' self-efficacy in inclusive education (as measured by the TEIP total scale and its factors, EII, EC, and EMB) and their attitudes towards inclusive education (as measured by the ORI total scale and its factors, BI, ICM, and SVG), Pearson's correlation coefficient was utilised. For determining the strength of the relationship, this study used the guidelines proposed by Cohen (1988), where coefficients between .10 and .29 reflect a weak relationship, coefficients between .30 and .49 reflect a moderate relationship, and coefficients above .50 reflect a strong relationship. As shown in Table 7.5, every relationship between Saudi kindergarten teachers' self-efficacy and attitudes on the TEIP and ORI factors was significantly positively correlated, with overall self-efficacy (TEIP) significantly correlated ($p < 0.01$) with overall teachers' attitudes (ORI) and the three factors. The strongest correlations were between the EC (collaboration efficacy) factor and the overall teachers' attitudes (ORI) scale ($r = .573$), and between the two TEIP and ORI total scales ($r = 0.569$). Moreover, the total TEIP scale correlated moderately positively with the three ORI factors ($r = .474-.458$), and the ORI total scale also was moderately positively correlated with EII and EMB factors ($r = .453, .466$). These results indicate that Saudi kindergarten teachers with more positive beliefs in their ability to teach children with disabilities had more positive attitudes towards inclusive education.

Table 7.5
Relationship Between Teachers' Self-Efficacy and Their Attitudes

	<i>TEIP</i>	<i>1</i>	<i>2</i>	<i>3</i>	<i>ORI</i>	<i>1</i>	<i>2</i>
<hr/>							
TEIP (total)							
1 Inclusive instructions (EII)	.896***						
2 Collaboration (EC)	.862***	.682***					
3 Managing behaviour (EMB)	.858***	.658***	.584***				
ORI (total)	.569***	.453***	.573***	.466***			
1 Benefits of integration (BI)	.466***	.350***	.481***	.392***	.795***		
2 Classroom management (ICM)	.474***	.385***	.473***	.385***	.852***	.428***	
3 Special vs. integrated general education (SVG)	.458***	.383***	.451***	.365***	.808***	.539***	.574***

Note. $N = 299$.

* $p < .05$. ** $p < .01$. *** $p < .001$.

7.3 Teacher-related Factors Associated with Teachers' Self-Efficacy and Attitudes

7.3.1 Examining the Influence of Teacher-related Factors on Self-Efficacy of Teachers

*Research Question 3.1. How do **teacher-related factors** (age; teaching position; years of teaching experience in general education; years of teaching experience in special education; years of teaching experience in inclusive education; training regarding children with disabilities or inclusive education; and having a family member, close relative, or friend with a disability) **influence teacher self-efficacy** in inclusive education in Saudi kindergarten settings?*

This research question was analysed using a standard multiple linear regression, which is a statistical tool that can be used to examine the relationship between one dependent variable and two or more independent variables (Pallant, 2013). The results of the multiple regression models presented below indicate the relationship between the dependent variables individually, the self-efficacy total scale and its three factors (EII, EC, and EMB), and the group of independent teacher-related variables: teacher age (Age); teacher teaching position (Position); years of teaching experience in general education (Experience GE); years of teaching experience in special education (Experience SE); years of teaching experience in inclusive education (Experience IE); training about children with disabilities or in inclusive education (Training); and having a family member, close relative, or friend with a disability (Family/friend with disability).

7.3.1.1 Self-Efficacy Total Scale

Table 7.6 shows the results of the regression analysis, which indicate that the group of independent variables significantly predicts the total level of teachers' self-efficacy ($F(7, 291) = 6.89, p < .000$). Table 7.7 shows the total sum of $R^2 = .14$; that is, about 14% of the variance in the dependent variable (total level of teachers' self-efficacy) can be explained by the combination of the predictor variables.

In order to assess which of the independent teacher-related variables included in the model was the best predictor of the total level of teachers' self-efficacy, the standardised partial regression coefficients (beta) were examined. Table 7.8 shows that the independent variables of experience in general education, experience in special education, experience in inclusive education, and family/friend with a disability were not statistically significant ($p > .05$). In other words, these variables did not make a statistically significant unique contribution to the total level of teachers' self-efficacy. In contrast, the independent variable of teacher age was negative and statistically significant ($p < .05$), which indicates that younger teachers had higher levels of self-efficacy. In addition, the independent variable of teaching position (special and general teachers) was positive and statistically significant ($p < .05$). This result shows that special education teachers' self-efficacy was statistically significantly more positive than general education teachers' self-efficacy. The variable of teacher age was found to have the largest beta value (beta = $-.20, p = .00$), followed by teaching position (beta = $.19, p = .02$). Based on these results, the variable of teacher age was the best predictor of the total level of teachers' self-efficacy in inclusive education in Saudi kindergarten settings.

7.3.1.2 Efficacy to Use Inclusive Instructions Factor

Table 7.6 shows the results of the regression analysis, which indicate that the group of independent variables significantly predicts the level of teachers' self-efficacy to use inclusive instructions ($F(7, 291) = 6.64, p < .000$). Table 7.7 shows the total sum of $R^2 = 13$; that is, about 13% of the variance in the dependent variable (teachers' self-efficacy) can be explained by the combination of the predictor variables.

Table 7.8 shows that the independent variables of age, experience in general education, experience in special education, experience in inclusive education, and family/friend with a disability did not make a significant contribution to the level of teachers' self-efficacy to use inclusive instructions ($p > .05$). In contrast, the independent variable of teaching position made a statistically positive significant contribution to teachers' self-efficacy in using inclusive instructions ($p < .05$), indicating that special education teachers' self-efficacy in this regard was higher than that of general education teachers. The variable of teacher position (special and general teachers) was found to have the largest beta value (beta = .20, $p = .02$). Based on this, the variable of teachers' position was the best predictor of teachers' self-efficacy to use inclusive instructions in kindergarten settings.

7.3.1.3 Efficacy in Collaboration Factor

Table 7.6 shows the results of the regression analysis, which indicate that the group of independent variables significantly predicts the level of teachers' self-efficacy in collaboration, ($F(7, 291) = 5.97, p < .000$). Table 7.7 shows the total sum of $R^2 = 12$; that is, about 12% of the variance in the dependent variable (teachers' self-efficacy in collaboration) can be explained by the combination of the predictor variables.

Table 7.8 shows that the independent variables of experience in general education, experience in special education, experience in inclusive education, and family/friend with a disability were not statistically significant ($p > .05$). However, the variable of teacher age was statistically negatively significant ($p < .05$), which indicates that younger teachers had higher levels of self-efficacy in collaboration. In addition, the variable of teaching position (special and general teachers) was positive and statistically significant ($p < .05$). This means special education teachers' self-efficacy in collaboration was higher than that of general education teachers. The variable of teacher age was found to be the best predictor of teachers' self-efficacy in collaboration in inclusive kindergarten settings (beta = .17, $p = .02$).

7.3.1.4 Efficacy in Managing Behaviour Factor

Tables 7.6 shows the results of regression analysis, which indicate that the group of independent variables significantly predicts the level of teachers' self-efficacy in managing behaviour, ($F(7, 291) = 3.43, p < .001$). Table 7.7 shows the total sum of $R^2 = .07$; that is, about 7% of the variance in the dependent variable (teachers' self-efficacy) can be explained by the combination of the predictor variables (see Table 7.8).

Table 7.8 shows that the independent variables of teacher position, experience in general education, experience in special education, experience in inclusive education, and family/friend with a disability were not statistically significant ($p > .05$). However, the independent variable of teacher age was negative and statistically significant ($p < .05$), indicating that younger teachers had higher levels of self-efficacy in managing behaviour. The variable of teacher age was found to be the best predictor of teachers' self-efficacy (beta = .20, $p = .00$) in managing behaviour in inclusive kindergarten settings.

Table 7.6

ANOVA of the Multiple Regression for Teacher-related Factors Influencing the Total Self-Efficacy Scale and its Three Factors

	Model	Sum of squares	<i>df</i>	Mean square	<i>F</i>	<i>p</i>
Self-efficacy total scale	Regression	28.097	7	4.014	6.89	.000***
	1 Residual	169.355	291	.582		
	Total	197.452	298			
Efficacy to use inclusive instructions factor	Regression	37.302	7	5.329	6.64	.000***
	1 Residual	233.206	291	.801		
	Total	270.508	298			
Efficacy in collaboration factor	Regression	30.838	7	4.405	5.977	.000***
	1 Residual	214.491	291	.737		
	Total	245.329	298			
Efficacy in managing behaviour factor	Regression	20.071	7	2.867	3.438	.001***
	1 Residual	242.685	291	.834		
	Total	262.756	298			

Note. $N = 299$.

* $p < .05$. ** $p < .01$. *** $p < .001$.

Table 7.7

Multiple Regression Model Summary for Teacher-related Factors Influencing the Total Self-Efficacy Scale and its Three Factors

	Model	R	R ²	Adjusted R square	Std. error of the estimate
Self-efficacy total scale	1	.37 ^a	.14	.12	.762
Efficacy to use inclusive instructions factor (EII)	1	.37 ^a	.13	.11	.895
Efficacy in collaboration factor (EC)	1	.35 ^a	.12	.10	.858
Efficacy in managing behaviour factor (EMB)	1	.27 ^a	.07	.05	.913

^a Predictors: (constant), age, position, experience GE, experience SE, experience IE, family/friend with a disability.

Table 7.8
Summary of Multiple Regression for Teacher-related Factors Influencing the Total Self- Efficacy Scale Model and its Three Factors

Model	Self- efficacy total scale					Efficacy to use inclusive instructions factor					Efficacy in collaboration factor					Efficacy in managing behaviour factor				
	B	SE	β	T	Sig	B	SE	β	T	Sig	B	SE	β	T	Sig	B	SE	β	T	Sig
(Constant)	4.661	.602		7.747	.009***	4.447	.706		6.299	.000**	4.859	.677		7.177	.000***	4.676	.720		6.492	.000***
Age	-.028	.011	-.193	-2.629	.00***	-.022	.012	-	-1.784	.075	-.027	.012	-.168	-2.263	.024**	-.034	.013	-.206	-2.712	.007***
Position	.388	.172	.194	2.252	.025**	.474	.202	.202	2.341	.020**	.390	.194	.174	2.007	.046**	.302	.206	.130	1.461	.145
Experience in general education	-.003	.008	-.029	-.394	.694	-.009	.010	-	-.928	.354	-.009	.009	-.066	-.904	.366	.008	.010	.058	.773	.440
Experience in special education	.018	.019	.064	.972	.332	.018	.022	.052	.791	.430	.009	.021	.028	.427	.670	.029	.023	.086	1.261	.208
Experience in inclusive education	.012	.011	.071	1.139	.256	.014	.012	.069	1.111	.268	.012	.012	.064	1.026	.306	.010	.013	.052	.801	.424
Training	-.138	.155	-.072	-.886	.377	-.162	.182	-	-.891	.374	-.156	.175	-.073	-.895	.372	-.094	.186	-.043	-.505	.614
Family/friend with disability	-.014	.107	-.007	-.134	.893	.009	.125	.004	.069	.945	.070	.120	-.032	-.580	.562	.018	.128	.008	.142	.887

Note. N = 299.

* $p < .05$. ** $p < .01$. *** $p < .001$.

7.3.2 Examining the Influence of Teachers Related Factors on Attitudes of Teachers

*Research Question 3.2. How do the **teacher-related factors** (age; teaching position; years of teaching experience in general education; years of teaching experience in special education; years of teaching experience in inclusive education; training about children with disabilities or in inclusive education; and having a family member, close relative, or friend with a disability) **influence teachers' attitudes** towards inclusive education in Saudi kindergarten settings?*

To answer this research question, a standard multiple regression analysis was used (Pallant, 2013). The results of the multiple regression models set out below indicate the relationship between the dependent variables individually—the teachers' attitudes total scale (ORI) and the three factors (BI, ICM, and SVG)—and the group of independent teacher-related variables.

7.3.2.1 Attitudes Total Scale

Table 7.9 shows the results of the regression analysis, which indicate that the group of independent variables significantly predicts teachers' attitudes towards inclusive education in kindergartens ($F(7, 291) = 5.12, p < .000$). Table 7.10 shows the total sum of $R^2 = .11$; that is, about 11% of the variance in the dependent variable (total score of the teachers' attitudes scale) can be explained by the combination of the predictor variables.

Table 7.11 shows that the independent variables of age, experience in general education, experience in special education, and family/friend with a disability were not statistically significant ($p > .05$). However, the independent variable of teaching position was positive and statistically significant ($p < .05$), indicating that special education teachers' overall attitudes were more positive than general education teachers' attitudes. In addition, the variable of experience in inclusive education was positive and statistically significant ($p < .05$). This means that as teachers' experience in inclusive education increases, their overall attitudes toward inclusive education become more positive. The variable of teaching position was the strongest predictor (beta = .20, $p = .02$) of kindergarten teachers' attitudes towards inclusive education.

7.3.2.2 Benefits of Integration Factor

Table 7.9 shows the results of the regression analysis, which indicate that the group of independent variables significantly predicts teachers' attitudes regarding the benefits of integration factor ($F(7, 291) = 6.14, p < .000$). Table 7.10 shows the total sum of $R^2 = .12$; that is, about 12% of the variance in the dependent variable (teachers' attitudes toward the benefits of integration) can be explained by the combination of the predictor variables. Table 7.11, however, shows the independent variables of age, teaching position, experience in general education, experience in special education, experience in inclusive education, and family/friend with a disability were not statistically significant ($p > .05$).

7.3.2.3 Integrated Classroom Management Factor

Table 7.9 shows the results of the regression analysis, which indicate that the group of independent variables significantly predicts teachers' attitudes regarding the integrated classroom management factor ($F(7, 291) = 2.08, p < .04$). Table 7.10 shows the total sum of $R^2 = .04$; that is, about 4% of the variance in the dependent variable (teachers' attitudes

toward integrated classroom management) can be explained by the combination of the predictor variables. Table 7.11 shows that the independent variables of age, experience in general education, experience in special education, experience in inclusive education, and family/friend with a disability were not statistically significant ($p > .05$). However, the independent variable of teaching position was positive and statistically significant ($p < .05$), indicating that special education teachers' attitudes towards integrated classroom management were higher than was the case for general education teachers. The variable of teaching position was the best predictor of teachers' attitudes (beta = .21, $p = .01$) towards integrated classroom management in kindergarten settings.

7.3.2.4 Special Versus Integrated General Education Factor

Table 7.9 shows the results of the regression analysis, which indicate that the group of independent variables significantly predicts teachers' attitudes regarding the special versus integrated general education factor ($F(7, 291) = 4.13, p < .000$). Table 7.10 shows the total sum of $R^2 = .09$; that is, about 9% of the variance in the dependent variable (teachers' attitudes towards special versus integrated general education) can be explained by the combination of the predictor variables. Table 7.11 shows that the independent variables of age, teaching position, experience in general education, experience in special education, and family/friend with a disability were not statistically significant ($p > .05$). However, the variable of teachers' experience in inclusive education was positive and statistically significant ($p < .05$), indicating that as teachers' experience in inclusive education increases, their attitudes become more positive towards the factor of special versus integrated general education on the ORI scale. The variable of teachers' experience in inclusive education was the strongest predictor of teachers' attitudes (beta = .15, $p = .01$) towards the factor of special versus integrated general education.

Table 7.9

ANOVA of the Multiple Regression Model for Teacher-related Factors Influencing the Attitudes Total Scale and its Three Factors

	Model	Sum of squares	df	Mean square	F	p
Attitudes total scale	Regression	16.895	7	2.41	5.121	.000***
	1 Residual	137.163	291	.472		
	Total	154.057	298			
Benefits of integration factor (BI)	Regression	31.728	7	4.533	6.143	.000***
	1 Residual	214.715	291	.738		
	Total	246.442	298			
Integrated classroom management factor (ICM)	Regression	8.590	7	1.227	2.082	.045**
	1 Residual	171.486	291	.589		
	Total	180.076	298			
Special versus integrated general education factor (SVG)	Regression	29.511	7	4.216	4.137	.000***
	1 Residual	296.531	291	.1019		
	Total	326.042	298			

Note. N = 299.

* $p < .05$. ** $p < .01$. *** $p < .001$.

Table 7.10

Multiple Regression Summary Model for Teacher-related Factors Influencing the Attitudes Total Scale and its Three Factors

	Model	R	R ²	Adjusted R Square	Std. error of the estimate
Attitudes total scale	1	.33 ^a	.11	.08	.686
Benefits of integration factor (BI)	1	.35 ^a	.12	.10	.858
Integrated classroom management factor (ICM)	1	.21 ^a	.04	.02	.767
Special versus integrated general education factor (SVG)	1	.30 ^a	.09	.06	1.009

^a Predictors: (constant), age, position, experience GE, experience SE, experience IE, family/friend with a disability.

Table 7.11*Summary of Multiple Regression for Teacher-related Factors Influencing the Attitudes Total Scale and its Three Factors*

Model	Attitudes total scale					Benefits of integration factor					Integrated classroom management factor					Special versus integrated general education factor				
	<i>B</i>	<i>SE</i>	β	<i>T</i>	<i>Sig</i>	<i>B</i>	<i>SE</i>	β	<i>T</i>	<i>Sig</i>	<i>B</i>	<i>SE</i>	β	<i>T</i>	<i>Sig</i>	<i>B</i>	<i>SE</i>	β	<i>T</i>	<i>Sig</i>
(Constant)	3.320	.541		6.13	.000***	4.405	.677		6.503	.000***	2.388	.605		3.944	.000***	3.686	.796		4.630	.000***
Age	-.015	.010	-.114	-1.53	.127	-.024	.012	-.150	-2.035	.143	-.007	.011	-.054	-.699	.485	-.015	.014	-.081	-1.075	.283
Position	.355	.155	.200	2.28	.023**	.349	.194	.156	1.797	.073	.415	.174	.217	2.391	.017**	.225	.228	.087	.984	.326
Experience in general education	-.005	.008	-.049	-.661	.509	-.010	.009	-.079	-1.080	.281	.005	.008	.043	.567	.571	-.019	.011	-.128	-1.721	.086
Experience in special education	-.005	.017	-.020	-.303	.762	.011	.021	.033	.495	.621	-.015	.019	-.056	-.805	.421	-.008	.025	-.021	-.304	.761
Experience in inclusive education	.019	.010	.128	2.022	.044**	.022	.012	.114	1.831	.068	.012	.011	.071	1.086	.278	.033	.014	.150	2.352	.019**
Training	-.082	.140	-.049	-.585	.559	-.157	.175	-.074	-.900	.369	.020	.156	.011	.130	.897	-.194	.206	-.079	-.944	.346
Family/friend with disability	.062	.035	.036	.647	.518	.114	.120	.053	.950	.343	.007	.107	.004	.069	.945	.103	.141	.041	.730	.466

Note. $N = 299$.* $p < .05$. ** $p < .01$. *** $p < .001$.

7.4 Child-related Factors Associated With Teachers' Self-Efficacy and Attitudes

7.4.1 Examining the Influence of Child-related Factors on Self-Efficacy of Teachers

Research Question 3.3. What is teachers' self-efficacy regarding the inclusion of children with specific types of disabilities in Saudi kindergarten settings?

To answer this research question, kindergarten teachers were asked to rank specific types of disabilities (behavioural disorders and autism, intellectual disabilities, hearing disabilities, learning disabilities, speech and language disabilities, visual disabilities, physical disabilities, and multiple disabilities) based on how confident they would feel with including children with these specific types of disabilities in their classrooms. The specific disabilities were ranked from first through to eighth. First (1 = first) represents teachers' highest level of self-efficacy and eight (8 = eighth) represents their lowest level of self-efficacy with including children with these specific disabilities in their classrooms. A Friedman test was conducted to determine the teachers' highest and lowest levels of self-efficacy with including children with specific disabilities. This test expresses a mean ranking, with the lowest score indicating teachers' lowest level of self-efficacy in regard to the inclusion of children with specific types of disabilities (Siegel & Castellan, 1988) and the significant differences amongst rankings. Table 7.12. shows the mean rankings, from the list of specific disabilities, for the teachers' highest and lowest levels of self-efficacy. Results show that kindergarten teachers ranked "speech and language disabilities" as the disability for which the teachers had the highest level of self-efficacy in terms of including

Table 7.13*Friedman Test for the Difference Among the Ranked Types of Disability*

Test statistics	
Chi-square	1,370.07
<i>df</i>	7
Asymp. sig.	.000***

Note. $N = 299$.* $p < .05$. ** $p < .01$. *** $p < .001$.

children with this specific disability in their inclusive classrooms (mean rank = 2.30). This was followed by “physical disabilities” (mean rank = 3.13). Teachers reported the lowest self-efficacy in relation to including children with “multiple disability” in their regular classrooms (mean rank = 7.83). Table 7.13 shows the results from the Friedman test, which

Table 7.12*Teachers' Reported Levels of Confidence for Including Children with Specific Disabilities*

Type of disability	Mean rank
Speech and language disabilities	2.30
Physical disabilities	3.13
Hearing disabilities	3.18
Learning disabilities	3.36
Visual disabilities	3.96
Intellectual disabilities	5.40
Behavioural disorders and autism	6.84
Multiple disabilities	7.83

Note. $N = 299$.

indicates that the specific types of disabilities were ranked significantly differently, $\chi^2(7) = 1370.076, p < .000$.

7.4.2 Examining the Influence of Child-Related Factors on Attitudes of Teachers

*Research Question 3.4. What are teachers' attitudes towards the inclusion of **children with specific types of disabilities** in Saudi kindergarten settings?*

To answer this question, descriptive statistics (means and standard deviations) were used. The responses to the 5-point Likert-type scale were: strongly agree =5, agree = 4, neutral = 3, disagree = 2, and strongly disagree = 1. Table 7.14 presents the mean scores of teachers' attitudes towards the inclusion of children with specific types of disabilities; these scores show that most kindergarten teachers held more positive attitudes towards including children with speech and language disabilities ($M=4.45$, $SD = .98$), noting that this mean score is above 4 (agree). Teachers also showed positive attitudes towards including children with hearing disabilities ($M=4.37$, $SD=1.08$), children with learning disabilities ($M = 4.36$, $SD = 1.09$), children with physical disabilities ($M=3.58$, $SD = 1.42$), and children with visual disabilities ($M =3.46$, $SD = 1.54$), in inclusive classrooms. However, they held negative attitudes towards including children with behavioural disorders and autism ($M =2.20$, $SD =1.23$) with this mean score being close to 2 (disagree), as well as towards including children with multiple disabilities ($M =2.34$, $SD =1.19$) and children with intellectual disabilities ($M =2.55$, $SD = 1.53$).

Table 7.14

Means and Standard Deviations of Teachers' Attitudes Towards Inclusion of Children with Specific Types of Disabilities

Types of disability	Mean	Std. deviation
Speech and language disabilities	4.45	.98
Hearing disabilities	4.37	1.08
Learning disabilities	4.36	1.09
Physical disabilities	3.58	1.42
Visual disabilities	3.46	1.54
Intellectual disabilities	2.55	1.53
Multiple disabilities	2.34	1.19
Behavioural disorders and autism	2.20	1.23

Note. $N = 299$.

7.5 Context-related Factors Associated With Teachers' Self-Efficacy and

Attitudes

7.5.1 Examining the Influence of Context-related Factors on Self-Efficacy of Teachers

Research Question 3.5 How do context-related factors (class size and number of special education teachers) influence Saudi teachers' self-efficacy in inclusive kindergarten settings?

To answer this research question, multiple regression analysis was used. The following results of the multiple regression models indicate the relationship between the dependent variables individually—the teachers' self-efficacy total scale (TEIP) and its three factors of EII, EC, and EMB—and the two independent context-related variables.

7.5.1.1 Self-Efficacy Total Scale

Table 7.15 shows the results of regression analysis, which indicate that the two variables significantly predict the total level of teachers' self-efficacy in inclusive education in kindergartens ($F(2, 296) = 8.60, p < .000$). Table 7.16 shows that the total sum of $R^2 = .05$; that is, about .05% of the variance in the dependent variable (total level of the teachers' self-efficacy scale) can be explained by the combination of the predictor variables.

Table 7.17 shows that the independent variable of number of special education teachers is not statistically significant ($p > .05$). In other words, this variable did not make a statistically significant unique contribution to the total level of teachers' self-efficacy in inclusive education. However, the independent variable of class size was negative and statistically significant ($p < .05$), which means that as the number of children in the classroom increases, teachers' self-efficacy in terms of inclusive education becomes less

positive. The variable of class size was found to have the largest beta value (beta = .22, $p = .00$). Based on this, the variable of class size was the best predictor of the total level of teachers' self-efficacy in inclusive education in kindergarten settings.

7.5.1.2 Efficacy to Use Inclusive Instructions Factor

Table 7.15 shows the results of regression analysis and indicates that the two variables significantly predict the level of teachers' self-efficacy to use inclusive instructions ($F(2, 296) = 9.53, p < .000$). Table 7.16 shows that the total sum of $R^2 = .06$; that is, about 6% of the variance in the dependent variable (teachers' self-efficacy to use inclusive instructions) can be explained by the combination of the predictor variables. Table 7.17 shows that the independent variable of number of special education teachers was not statistically significant. However, the independent variable of class size was negative and statistically significant, indicating that as the number of children in the classroom increases, teachers' self-efficacy in the use of inclusive instructions becomes less positive. The variable of class size was the strongest predictor of teachers' self-efficacy to use inclusive instructions in inclusive kindergarten classrooms (beta = .23, $p = .00$).

7.5.1.3 Efficacy in Collaboration Factor

Table 7.15 shows the results of regression analysis and indicates that the two context-related variables significantly predict the level of teachers' self-efficacy in collaboration ($F(2, 296) = 7.67, p < .001$). Table 7.16 shows the total sum of $R^2 = .04$; that is, about 4% of the variance in teachers' self-efficacy in collaboration can be explained by the combination of the predictor variables. The variable of the number of special education teachers was not statistically significant; however, the independent variable of class size was negative and statistically significant, and was the best predictor of teachers' self-efficacy in collaboration in inclusive kindergarten classrooms (beta = .23, $p = .00$).

7.5.1.4 Efficacy in Managing Behaviour Factor

Table 7.15 shows the results of regression analysis and indicates that the two variables significantly predict the level of teachers' self-efficacy in managing behaviour ($F(2, 296) = 3.22, p < .001$). Table 7.16 shows the total sum of $R^2 = .02$; that is, about 2% of the variance in the dependent variable (teachers' self-efficacy in managing behaviour) can be explained by the combination of the predictor variables. Table 7.17 shows that the independent variable of the number of special education teachers was not statistically significant; however, the independent variable of class size was negative and statistically significant, and was the best predictor of teachers' self-efficacy in managing behaviour in inclusive kindergarten classrooms (beta = .14, $p = .00$).

Table 7.15

ANOVA of the Multiple Regression Model for Context-related Factors Influencing the Self-Efficacy Total Scale and its Three Factors

	Model	Sum of squares	df	Mean square	F	p
Self-efficacy total scale	Regression	10.845	2	5.42	8.601	.000***
	1 Residual	186.607	296	.630		
	Total	197.452	298			
Efficacy to use inclusive instructions factor (EII)	Regression	16.374	2	8.187	9.536	.000***
	1 Residual	254.134	296	.589		
	Total	270.508	298			
Efficacy in collaboration factor (EC)	Regression	12.091	2	6.046	7.672	.001***
	1 Residual	233.238	296	.788		
	Total	245.329	298			
Efficacy in managing behaviour factor (EMB)	Regression	5.602	2	2.801	3.22	.041**
	1 Residual	257.155	296	.869		
	Total	262.756	298			

Note. N = 299.

* $p < .05$. ** $p < .01$. *** $p < .001$.

Table 7.16

Multiple Regression Summary Model for Context-related Factors Influencing the Self-Efficacy Total Scale and its Three Factors

	Model	R	R ²	Adjusted R square	Std. error of the estimate
Self-efficacy total scale	1	.23 ^a	.05	.04	.794
Efficacy to use inclusive instructions factor (EII)	1	.24 ^a	.06	.05	.926
Efficacy in collaboration factors (EC)	1	.22 ^a	.04	.04	.887
Efficacy in managing behaviour factors (EMB)	1	.14 ^a	.02	.01	.932

^a Predictors: (constant), class size, number of special education teachers.

Table 7.17

Summary of Multiple Regression for Context-related Factors Influencing the Self-Efficacy Total Scale and its Three Factors

Model	Self-efficacy total scale					Efficacy to use inclusive instructions factor (EII)					Efficacy in collaboration factor (EC)					Efficacy in managing behaviour factor (EMB)				
	<i>B</i>	<i>SE</i>	β	<i>T</i>	Sig	<i>B</i>	<i>SE</i>	β	<i>T</i>	Sig	<i>B</i>	<i>SE</i>	β	<i>T</i>	Sig	<i>B</i>	<i>SE</i>	β	<i>T</i>	Sig
(Constant)	4.386	.152		28.829	.000***	4.567	.178		25.72	.000***	4.449	.170		26.156	.000***	4.142	.179		23.193	.000***
Class size	-.019	.005	-	-3.947	.000***	-.023	.006	-	-4.079	.000***	-.020	.005	-.213	-3.750	.000***	-.014	.006	-.142	-2.461	.014**
			.224					.231												
Number of special education teachers	-.028	.029	-	-.953	.341	-.042	.034	-	-1.227	.221	.027	.033	.047	.828	.408	-.015	.034	-.025	-.427	.670
			.054					.069												

Note. $N = 299$.

* $p < .05$. ** $p < .01$. *** $p < .001$.

7.5.2 Examining the Influence of Context-related Factors on Attitudes of Teachers

*Research Question 3.6 How do **context-related factors** (class size and number of special education teachers) influence Saudi teachers' attitudes towards inclusive education in kindergarten settings?*

To answer this research question, multiple regression analysis was used. The following results of the multiple regression models indicate the relationship between the dependent variables individually—teachers' attitudes total scale (ORI) and its three factors (BI, ICM, and SVG)—and the two independent context-related variables.

7.5.2.1 Attitudes Total Scale

Table 7.18 shows the results of regression analysis, which indicate that the two variables significantly predict teachers' attitudes towards inclusive education in kindergartens ($F(2, 296) = 10.07, p < .000$). Table 7.19 shows that the total sum of $R^2 = .06$; that is, about .6% of the variance in the dependent variable (teachers' attitudes total scale) can be explained by the combination of the predictor variables. Table 7.20 shows that the independent variable of number of special education teachers was not statistically significant. However, the independent variable of class size was negative and statistically significant ($p < .05$). This means that as the number of children in the classroom increases, overall teachers' attitudes towards inclusive education become more negative. The variable of class size was the best predictor of the teachers' attitudes overall towards inclusive education in kindergarten settings (beta = .25, $p = .00$).

7.5.2.2 Benefits of Integration Factor

The results of the regression analysis shown in Table 7.18 indicate that the two variables significantly predict teachers' attitudes towards the benefits of integration ($F(2, 296) = 13.33, p < .001$) with an $R^2 = .08$; that is, about .08% of the variance in the dependent variable (teachers' attitudes towards the benefits of integration) can be explained by the combination of the predictor variables (see Table 7.19). Table 7.20 shows that the variable of the number of special education teachers was not statistically significant; however, the variable of class size was negative and statistically significant, and was the best predictor of teachers' attitudes towards the benefits of integration in inclusive kindergarten classrooms ($\beta = .27, p = .00$).

7.5.2.3 Integrated Classroom Management Factor

Table 7.18 shows the results of regression analysis and indicates that the two variables significantly predict teachers' attitudes towards integrated classroom management, ($F(2, 296) = 4.42, p < .01$). Table 7.19 shows that the total sum of $R^2 = .02$; that is, about 2% of the variance in the dependent variable (teachers' attitudes towards integrated classroom management) can be explained by the combination of the predictor variables. Table 7.20 shows that the variable of the number of special education teachers was not statistically significant; however, the variable of class size was negative and statistically significant, and was the best predictor of teachers' attitudes towards integrated classroom management in inclusive kindergarten classrooms ($\beta = .16, p = .00$).

7.5.2.4 Special Versus Integrated General Education Factor

Table 7.18 shows the results of regression analysis, which indicate that the two variables significantly predict teachers' attitudes towards the SVG factor ($F(2, 296) = 7.748, p < .00$). Table 7.19 shows the total sum of $R^2 = .05$; that is, about 5% of the variance in the dependent variable (teachers' attitudes towards special versus integrated general education) can be explained by the combination of the predictor variables. Table 7.20 shows that the variable of the number of special education teachers was not statistically significant; however, the variable of class size was negative and statistically significant, and was the best predictor of teachers' attitudes towards the SVG factor ($\beta = .19, p = .00$).

Table 7.18

ANOVA of the Multiple Regression Model for Context-related Factors Influencing the Attitudes Total Scale and its Three Factors

	Model	Sum of squares	<i>df</i>	Mean square	<i>F</i>	<i>p</i>
Attitudes total scale	Regression	9.817	2	4.908	10.073	.000***
	1 Residual	144.240	296	.487		
	Total	154.057	298			
Benefits of integration factor (BI)	Regression	20.372	2	10.186	13.337	.000***
	1 Residual	226.070	296	.764		
	Total	246.442	298			
Integrated classroom management factor (ICM)	Regression	5.223	2	2.612	4.421	.013**
	1 Residual	174.853	296	.591		
	Total	180.076	298			
Special versus integrated general education factor (SVG)	Regression	16.219	2	8.109	7.748	.001***
	1 Residual	309.824	296	1.047		
	Total	326.042	298			

Note. $N = 299$.

* $p < .05$. ** $p < .01$. *** $p < .001$.

Table 7.19

Multiple Regression Summary Model for Context-related Factors Influencing the Attitudes Total Scale its Three Factors

	Model	<i>R</i>	<i>R</i> ²	Adjusted <i>R</i> square	Std. error of the estimate
Attitudes total scale	1	.25 ^a	.06	.05	.698
Benefits of integration factor (BI)	1	.28 ^a	.08	.07	.873
Integrated classroom management factor (ICM)	1	.17 ^a	.02	.02	.768
Special versus integrated general education factor (SVG)	1	.22 ^a	.05	.04	1.023

^a Predictors: (constant), class size, number of special education teachers.

Table 7.20

Summary of Multiple Regression for Context-related Factors Influencing the Attitudes Total Scale and its Three Factors

Model	Attitudes total scale					Benefits of integration factor (BI)					Integrated classroom management factor (ICM)				Special versus integrated general education factor (SVG)					
	<i>B</i>	<i>SE</i>	β	<i>T</i>	Sig	<i>B</i>	<i>SE</i>	β	<i>T</i>	Sig	<i>B</i>	<i>SE</i>	<i>T</i>	Sig	<i>B</i>	<i>SE</i>	β	<i>T</i>	Sig	
(Constant)	3.536	.134		26.437	.000***	4.568	.167		27.277	.000***	2.896	.147		19.663	.000***	3.312	.196		16.892	.000***
Class size	-.019	.004	-	-4.467	.000***	-.026	.005	-	-4.897	.000***	-.013	.005	-	-2.791	.006***	-.021	.006	-	-3.374	.001***
			.252					.274					.160				.192			
Number of special education teachers	.020	.026	.045	.794	.428	-.040	.032	-	-1.240	.216	.035	.028	.072	1.246	.214	.086	.038	.130	2.292	.218
								.069												

Note. $N = 299$.

* $p < .05$. ** $p < .01$. *** $p < .001$.

7.6. Teachers' Perceptions of Barriers to Inclusive Education

Research Question 4.1 What are Saudi kindergarten teachers' perceptions of the barriers to the successful inclusion of children with disabilities in kindergarten settings?

To answer this research question, kindergarten teachers were asked to rank the most significant barriers limiting the inclusion of children with disabilities in inclusive kindergarten classrooms. Barriers were ranked as most significant (1= first) to least significant (ranked as number 13). A Friedman test was conducted to determine the significance of the barriers ranked by teachers. This test expresses a mean ranking, with the lowest score indicating the most significant barrier (Siegel & Castellan, 1988), and indicates the significant difference amongst rankings. Table 7.21. shows the mean rankings for each barrier. Results show that kindergarten teachers ranked “the nature and severity of the child’s disability” as the most significant barrier (*mean rank* = 2.29), followed by “limited paraprofessionals to support children with a disability in the kindergarten” (*mean rank* = 3.01), while they ranked “negative religious and cultural beliefs towards the inclusion of children with disabilities in the inclusive kindergarten” as the least significant barrier (*mean rank* = 12.71). Table 7.22 displays the Friedman test results for the significance of the difference between barriers, and indicates that the barriers were ranked differently, $\chi^2(2) = 2449.28, p < .000$.

Table 7.21*Teachers' Mean Ranking of Barriers to Including Children with Disabilities in Inclusive Kindergarten Classrooms*

Barriers	Mean rank
The nature and severity of the child's disability means they are unable to be included in the inclusive kindergarten.	2.29
Limited paraprofessionals to support children with a disability in the kindergarten.	3.01
Large class size in which the child with disability attends	3.89
Lack of teachers' knowledge and skills in including children with disabilities.	4.38
Inappropriate physical environment for children with disabilities.	4.62
Lack of teachers' time.	6.79
Lack of laws and policies related to the inclusion of children with disabilities.	7.53
Lack of curriculum and materials to support the learning and teaching of children with disabilities.	7.66
Lack of kindergarten Principal and the educational supervisor's support for the inclusion of children with disabilities.	7.72
Poor involvement and support from families of children with disabilities.	9.62
Negative teachers' attitudes toward inclusion of children with disabilities.	10.35
Lack of teachers' confidence to support children with disabilities in their classroom.	10.44
Negative religious and cultural beliefs towards the inclusion of children with disabilities in the inclusive kindergarten.	12.71

Note. $N = 299$.

* $p < .05$. ** $p < .01$. *** $p < .001$.

Table 7.22

Result of a Friedman Test for the Difference Among the Ranked Barriers to Inclusion of Children with Disabilities in Inclusive Kindergarten Classrooms

Test statistics	
Chi-square	2,449.28
<i>df</i>	12
Asymp. sig.	.000***

Note. $N = 299$.

* $p < .05$. ** $p < .01$. *** $p < .001$.

7.7 Summary

This chapter has presented the results of quantitative analyses of the questionnaire data. With respect to the second research aim and its related questions (2.1, 2.2, 2.3, 2.4, 2.5), the descriptive statistics, t-tests, and Pearson's correlation coefficient analysis revealed that Saudi teachers generally appeared to have somewhat positive self-efficacy and moderately positive attitudes towards inclusive education in kindergarten settings. Special education teachers, however, held more positive self-efficacy and attitudes across the total TEIP and ORI scales and their factors than general education teachers. A significant strong positive relationship was found between teachers' self-efficacy and attitudes towards inclusive education.

To address the third research aim and its related research questions (3.1, 3.2, 3.3, 3.4, 3.5, 3.6), multiple regression analyses, ranking, and descriptive analysis were conducted. The multiple regression analysis indicated that teacher-related factors (teachers' age, teaching position) had a statistically significant influence on both teachers' self-efficacy and attitudes. These results also showed that one teacher-related factor (experience in inclusive education) had a statistically significant influence only on teachers' attitudes towards inclusive education. While the rest of the teacher-related factors (years of teaching experience in general education; years of teaching experience in special education; training about children with disabilities or in inclusive education; having a family member, close relative, or friend with a disability) did not make any significant contribution to the

prediction of teachers' self-efficacy or attitudes. Further, one of the context-related factors (class size) had a negative and significant influence on both teachers' self-efficacy and attitudes, while the other context-related factor (number of special education teachers) did not make any significant contribution to the prediction of teachers' self-efficacy or attitudes. In regard to child-related factors, ranking and descriptive analysis indicated that teachers tended to have positive self-efficacy and attitudes towards including children with speech and language disorders, hearing disabilities, learning disabilities, physical disabilities, or visual disabilities in their inclusive classrooms. In contrast, teachers showed lower self-efficacy and less positive attitudes towards inclusion of children with behavioural disorders and autism, intellectual disabilities, and multiple disabilities.

To address the fourth research aim and its related question (4.1), ranking analysis was conducted. Results showed that kindergarten teachers ranked "the nature and severity of the child's disability" as the most significant barrier to effectively including children with disabilities in Saudi inclusive kindergarten settings, followed by "limited paraprofessionals to support children with a disability in the kindergarten" and "large class size." They ranked "negative religious and cultural beliefs towards the inclusion of children with disabilities in the inclusive kindergarten" as the least significant barrier to successfully including children with disabilities in inclusive kindergarten settings.

In addition to the quantitative questionnaire data, qualitative interview data were also collected in order to gain a deeper understanding of the factors influencing teachers' self-efficacy and attitudes towards inclusive education, and of teachers' perceptions of barriers to inclusive education in Saudi kindergarten settings. The semi-structured interview findings will be discussed in the following chapter.

Chapter 8: Results of the Qualitative Analyses

8.1 Introduction

This chapter presents the results of the qualitative phase of this study, which were derived from the semi-structured interviews conducted with a total of eight kindergarten teachers who consented to participate in the interviews. Four of these teachers were general education teachers and four were special education teachers, all employed in public inclusive kindergartens in Riyadh, the capital city of Saudi Arabia. They were selected purposefully according to their positive or less positive self-reports of self-efficacy and attitude towards inclusive education in the questionnaire. The objectives of the interviews were to explore the reported factors influencing Saudi kindergarten teachers' positive and less positive self-efficacy and attitudes towards inclusive education, and their reported perceptions of barriers to inclusive education in kindergarten settings.

The interview data were interrogated to address the three research questions related to the third and fourth research aims, which were as follows:

3.7. What are the reported factors influencing Saudi general and special education teachers' self-efficacy in inclusive education in Saudi kindergarten settings?

3.8. What are the reported factors influencing Saudi general and special education teachers' attitudes towards inclusive education in Saudi kindergarten settings?

4.1. What are Saudi kindergarten teachers' perceptions of the barriers to the successful inclusion of children with disabilities in kindergarten settings?

This chapter first presents the characteristics of the interview participants and then outlines the results of the key themes that emerged from the qualitative thematic analysis.

8.2. Characteristics of Interview Participants

Chapter 5 presented detailed information about the rationale for selection of the participants and the procedures employed for the interview phase of the study. Here, Table 8.1 provides a brief description of the participant characteristics to reorientate the reader to the context for understanding the findings.

Table 8.1
Summary of Interview Participants' Demographic Information

Participant	Teaching position	Age	Years of teaching experience in inclusive education	Class size	Highest qualification	Training about children with disabilities or in inclusive education
Positive self-efficacy and attitudes						
Amal	Special	35	6	30	Masters	Yes
Shahad	Special	43	5	30	Masters	Yes
Rana	General	36	3	25	Bachelors	Yes
Fatima	General	37	1	30	Bachelors	Yes
Less positive self-efficacy and attitudes						
Salma	Special	30	4	30	Bachelors	Yes
Moneerah	Special	34	2	30	Bachelors	Yes
Dalal	General	39	1	25	Bachelors	No
Sahar	General	35	1	30	Bachelors	No

Note. All the names used in this table are aliases, in order to protect participants' identities.

The interview sample comprised four general education teachers and four special education teachers. Six out of eight participants held an undergraduate teaching qualification while two teachers had continued their studies and achieved a two-year master's degree with a focus on special education. The participants' ages ranged from 30 to

43 years. Regarding class sizes, the number of children taught by the interview participants was between 25 and 30 children. Six participants had attended training courses on disabilities or in inclusive education, while the two remaining participants had not participated in any training courses. All the interviewees were given a unique alias to protect their identity.

8.3 Results

The data collected from the semi-structured interviews were transcribed and analysed using thematic analysis. The thematic analysis entailed identifying the key themes emerging from the responses. The rationale for using thematic analysis and the process used was described in detail in Chapter 5. Key themes were evident from the thematic analysis. With respect to the third research aim and its related qualitative research question (3.7), factors influencing teachers' positive self-efficacy yielded four themes. Research question 3.7 also covered factors influencing teachers' less positive self-efficacy, and this aspect of the question yielded three themes. With respect to the second qualitative research question (3.8), three themes emerged regarding factors influencing teachers' positive attitudes. Research question 3.8 also refers to factors influencing teachers' less positive attitudes, and two themes emerged for this aspect of the question. With respect to the fourth research aim and its associated research question (4.1), reported barriers to inclusive education yielded nine themes.

8.3.1 Factors Influencing Teachers' Positive Self-Efficacy

3.7. What are the reported factors influencing Saudi general and special education teachers' self-efficacy in inclusive education in Saudi kindergarten settings?

To answer this research question, thematic analysis was used. Rana, Fatima, Amal, and Shahad's questionnaire and interview responses revealed they had positive self-efficacy. There were a variety of factors which influenced their positive self-efficacy, and these were organised according to four themes, namely: (1) encouragement from the Principal and parents, (2) teachers' passion and enthusiasm, (3) collaboration with special education teachers, and (4) successful achievement of children with disabilities. Most of these themes were mentioned by one of these four teachers, while the theme of encouragement from the Principal and parents was mentioned by two. Thus, these themes are discussed below in order from those most to least frequently mentioned.

8.3.1.1 Teachers' Passion and Enthusiasm

Fatima, a general education teacher, indicated that a teacher-related factor influencing her high level of self-efficacy towards including children with disabilities in her regular classroom was her passion for teaching. This is reflected in her statement: "I really love teaching and always do my best, and I believe any teacher interested in her job would be ready to do her best to assist her children."

Further, Shahad, who is a special education teacher and holds a master's degree in special education, attributed her positive self-efficacy and feeling of comfort towards teaching children with disabilities in the inclusive setting to the teacher-related factor of her enthusiasm for learning and gaining new knowledge regarding working in such settings:

Now, I feel more comfortable and confident working with my children with disabilities because I have given significant attention to obtaining knowledge, and I keep learning something new every day to develop my skills and expand my capacity to serve children with disabilities in this inclusive setting.

8.3.1.2 Encouragement From the Principal and Parents

Rana, a general education teacher, cited the context-related factor of encouragement from the kindergarten Principal and from the children's parents. She identified this factor as having had a great influence in building her self-efficacy and her success in working in an inclusive setting. She said:

For sure there are teachers who are better than me, yet when I see the kindergarten Principal trusting my abilities and always asking me to teach some children with disabilities in my classroom, and when I see the parents confirm that their children are getting better and making progress, that, of course, makes me feel good about myself, increases my confidence and makes me feel that I am successful in my work with children with disabilities.

8.3.1.3 Collaboration with Special Education Teacher

Fatima also indicated the influence of a context-related factor—collaboration with special education teachers—in building her positive self-efficacy in working in inclusive settings. She said:

The great collaboration, assistance and support I get from special education teachers in my class provide me with very valuable information about how to make changes in order to help children with disabilities; this raises my confidence and my ability to work with those children has improved a lot.

8.3.1.4 Successful Achievement of Children with Disabilities

Amal, a special education teacher, expressed her satisfaction regarding her ability to teach children with various types of disabilities in the inclusive kindergarten setting. She described this as being influenced by a child-related factor: she measures her success by the successful achievement of children with disabilities at the end of the year. As she stated:

So far, I'm satisfied with my ability in teaching children with various types of disabilities and managing their behaviour because I measure my success by the progress of children with disabilities at the end of the year, which I'm satisfied with.

8.3.2 Factors Influencing Teachers' Less Positive Self-Efficacy

3.7. What are the reported factors influencing Saudi general and special education teachers' self-efficacy in inclusive education in Saudi kindergarten settings?

To answer this research question, thematic analysis was used. Two general education teachers, Dalal and Sahar, and two special education teachers, Salma and Moneerah, reported less positive self-efficacy in the questionnaire, which was supported by their interview data. Their interview responses were divided into three themes based on factors influencing their negative self-efficacy. These themes were: lack of knowledge and experience; lack of collaboration with Principal/special education teachers; and teaching outside the area of specialisation. These themes are discussed in order below, from the most to the least frequently mentioned.

8.3.2.1 Lack of Knowledge and Experience

Dalal displayed a lack of self-efficacy in teaching children with disabilities in her inclusive classroom due to a teacher-related factor—her limited knowledge. As she said:

I cannot see myself as a successful teacher because I don't have enough knowledge about how to deal with children with disabilities, and I'm depending on the special education teacher's assistance because most of the included children in my classroom have hearing disabilities, and I do not know how to communicate with them.

Similarly, Sahar showed her lack of self-efficacy in teaching children with disabilities, by expressing her lack of experience and knowledge: "I am very exhausted with dealing with children with Attention-Deficit/Hyperactivity Disorder and behavioural

disorders because I do not have enough experience and do not know the best way to deal with them.”

Further, Moneerah revealed her lack of self-efficacy in her ability to work in inclusive classrooms due to a teacher-related factor—her lack of experience in inclusive education. As she stated, “I am not successful and do not feel comfortable working with my children with disabilities in the inclusive classroom due to my minimal years of experience in inclusive education.”

8.3.2.2 Lack of Collaboration with Principal and Special Education Teachers

Sahar’s lack of self-efficacy in managing the behaviour of children with disabilities is also influenced by a context-related factor—a lack of collaboration with the kindergarten Principal and special education teachers. She said:

Children with behavioural disorders in my classroom do not receive individual education plans or sessions in the resource room with the special education teachers and actually there is no collaboration from the kindergarten Principal and the special education teachers. They say, “you are responsible for teaching and dealing with those children because the children only have behavioural disorders.”

8.3.2.3 Teaching Outside the Area of Specialisation

Salma, who specialises in hearing disabilities, commented in the interview about her lack self-efficacy in teaching children with specific types of disabilities that are different from her area of specialisation:

I don’t see myself as successful because I’m still struggling with teaching children with specific types of disabilities that are in areas different from my area of specialisation, like intellectual disabilities and autism. Teaching out of our area of

specialisation is really affecting our ability to manage and address the needs of children with different types of disabilities. It affects the quality of our teaching in inclusive classrooms and the individual sessions in the resource room, so children with disabilities' development and learning can become vulnerable due to having to teach outside of our specialisation area.

In summary, teachers' positive self-efficacy in inclusive education appeared to be influenced by the teacher-related factors of teachers' passion and enthusiasm and by the child-related factor of successful achievement of children with disabilities. Teachers' positive self-efficacy was also influenced by the context-related factors of Principal and parents' encouragement and by collaboration with special education teachers. In contrast, teacher's less positive self-efficacy was shown to be influenced by the teacher-related factor of lack of knowledge and experience and by the context-related factors of lack of collaboration with the Principal and special education teachers, and teaching outside their area of specialisation.

8.3.3 Factors Influencing Teachers' Positive Attitudes

3.8. What are the reported factors influencing Saudi kindergarten general and special education teachers' attitudes towards inclusive education in Saudi kindergarten settings?

To answer this qualitative research question, thematic analysis was used. Four interview participants who reported positive attitudes in the questionnaire were asked to describe their perceptions about including children with disabilities in kindergarten settings. Their responses revealed several factors influencing their positive attitudes towards including children with disabilities in their inclusive kindergarten. These responses were divided into three themes, namely: (1) benefits for children with and without disabilities, (2) empathy for the families of children with disabilities, and (3) work-related enjoyment. These themes are discussed in order below, from the most to the least frequently mentioned.

8.3.3.1 Benefits for Children With and Without Disabilities

Rana revealed that the remarkable academic and social benefits for children with and without disabilities in the inclusive setting encouraged her to be supportive and positive towards inclusive education. She stated:

I am very supportive of full inclusion because I have seen many children with different types of disabilities and without disabilities benefit from inclusive education. For example, we had a child with autism who used to live in his own world—he would not speak to anybody! After only one year of inclusion, he has made great progress. Inclusion has been really good for him because he used to be silent all the time, and when the teacher asked him any questions, he would not make eye contact. Now, he is communicating with a few words and smiling at her and his classmates.

Rana elaborated more on the child-related factors that influenced her support for inclusive education in the kindergarten setting. She indicated that an inclusive setting is the most appropriate placement for children with disabilities, and argued that this was because it provides these children and those without disabilities opportunities to develop friendships with each other. This view has influenced her positive attitude towards inclusive education in the kindergarten setting, as follows:

In terms of the social and academic benefits for children with disabilities, the inclusive kindergarten is the most appropriate placement for them; children with disabilities must not be isolated. I really see inclusive kindergarten as extremely beneficial for children with and without disabilities because they can develop friendships and learn social skills from each other, and both their respect and understanding grow when children of different abilities learn and play together.

Rana's attitudes were supported by Fatima. Specifically, Fatima discussed some child-related factors that influenced her positive beliefs about the benefits of inclusive education in the kindergarten setting for both children with and without disabilities, where they can learn from each other. She stated that,

I prefer inclusive education because it is very useful for children with and without disabilities. For example, all children with disabilities who are included in my class have hearing disabilities, and some of them have made excellent progress in one year. We have noticed the difference; for example, they have started to communicate verbally with a few words and call friends by their names. In addition, the children without disabilities have started to learn how to communicate with sign language with their peers with hearing disabilities.

Amal also advocated for including children with disabilities in the regular classroom. She identified that child-related factors underpinned this belief, as she perceived that all children with different types and severities of disability would exhibit some progress, whether academically or socially. Amal stated:

Regardless of how severe their disability is, including them with children without disabilities is helpful for them. Children with disabilities will benefit from mixing with children without disabilities, regardless of their disability type, and they will respond. Let us say, whether it is 10% or 1%, ultimately, they will benefit from inclusion, both socially and academically.

Amal shared another child-related factor that influenced her positive attitude towards inclusive education. She believed that inclusion had a positive impact on improving the psychological health of children with disabilities who have siblings without disabilities attending the same inclusive kindergarten. She said:

Inclusive education will improve children with disabilities' psychological health, as well as that of their parents. For example, some of the children with disabilities have siblings without disabilities, so they can attend the same kindergarten. This is good for the siblings, and their parents do not have to drive everyone to separate kindergartens.

Shahad identified her positive attitude as being influenced by a child-related factor. Specifically, Shahad felt positive about inclusive education because of the social and academic progress of children with disabilities in inclusive setting: "I believe in inclusive education, and I accept all children with disabilities being included because I see the children with disabilities' social and academic skills improving."

8.3.3.2 Empathy for the Families of Children with Disabilities

Rana expressed a teacher-related factor that influenced her positive attitudes. She reported empathy for the families of children with disabilities and thus supported their wish to see their child educated with their peers: “I always put myself in the parents’ shoes. Of course, the parents wish to see their child studying in ordinary kindergarten like the rest of the children, so why would we deprive the children with disabilities of the opportunity to join the rest of their peers?.”

8.3.3.3 Work-related Enjoyment

Rana elaborated more on teacher-related factors that influenced her support for inclusive education in the kindergarten setting and expressed her job enjoyment as follows:

Inclusion is stressful sometimes, but it is enjoyable for me because I learn new things about the children every day, and I can say that my life has changed for the better because of the inclusion experience. In my view, life has become deeper and more meaningful, and the way I deal with all children, with and without disabilities, has improved.

8.3.4 Factors Influencing Teachers' Less Positive Attitudes

3.8. What are the reported factors influencing Saudi general and special education teachers' attitudes towards inclusive education in Saudi kindergarten settings?

To answer this qualitative research question, thematic analysis was used. For the two general education teachers, Dalal and Sahar, and two special education teachers, Salma and Moneerah, who scored less positive on the attitude scale (ORI), their interview data also revealed less positive attitudes. Their interview responses divided into two themes based on the factors influencing their less positive attitudes which are type and severity of disabilities and detrimental effects on children with and without disabilities.

8.3.4.1 Type and Severity of Disabilities

Sahar described the influence of a child-related factor on her attitudes towards including children with disabilities; specifically, the type and severity of disabilities. She perceived that inclusive education for children with severe disabilities is not appropriate due to the potential for their behaviour to harm other children and teachers, stating that,

it depends on the type of disability, so if the type of disability is mild, such as a speech disorder, inclusive kindergarten is the appropriate placement. However, for severe disabilities, such as severe behavioural disorders and intellectual disability, the inclusive kindergarten is really not appropriate for children with these types of disabilities. They harm other children and us with their behaviours, and we cannot find solutions for this.

Salma, who specialises in hearing disability, expressed unsupportive attitudes towards including children with some specific types of disabilities, such as severe

intellectual disability and autism spectrum disorder, and described these attitudes as being influenced by a child-related factor—the type and severity of disability. She stated:

I don't really support implementing the inclusive program currently. I support only the inclusion of children with mild and moderate disabilities, but I do not support inclusion for children with severe disabilities, such as intellectual disabilities and autism., due to the lack of some inclusive support services.

8.3.4.2 Detrimental Effects on Children With and Without Disabilities

Dalal did not support full inclusion, a model where children with disabilities are included with their peers without disabilities in the regular classroom for the entire day. Instead, she thought that children with disabilities should be included for only part of the day. She suggested that for the remainder of the day they should be educated by special education teachers in the resource rooms. She rejected the idea of full inclusion because of the influence of a child-related factor: that is, her belief that the inclusion of children with disabilities has a detrimental effect on the development of children without disabilities. As she stated:

I agree with partial inclusion but not full inclusion, where children with and without disabilities are not in the same class all the time. They can be included only in the playtime outside the classroom and meal time. This is because children with disabilities distract children without disabilities. For example, there is a girl in the classroom who has a hearing disability; she speaks very loudly, but she is not aware of doing this. When she is speaking, the children pay attention to her and do not focus on the lesson. In addition, there is a child with hyperactivity and the other children imitate him.

Moneerah described the influence of a child-related factor on her unsupportive attitudes towards inclusive education in the kindergarten setting. She identified the detrimental impact of children without disabilities on their peers with disabilities, stating:

As I'm specialised in hearing disability, I prefer separation over inclusion because of the sensitivity of children with hearing disabilities and speech and language disorders, as children without disabilities abuse them whenever they talk or when they produce some strange sounds. Especially, children with speech and language disorders feel ashamed when talking or participating because the children without disabilities laugh at and mock them.

In summary, teachers' positive attitudes towards inclusive education appeared to be influenced by the teacher-related factor of work-related enjoyment, the child-related factor of the benefits for children with and without disabilities, and the context-related factor of empathy for the families of children with disabilities. In contrast, teachers' less positive attitudes appeared to be influenced by the child-related factors of the type and severity of disabilities and the detrimental effects on children with and without disabilities.

8.3.5 Reported Barriers to Inclusive Education

4.1. What are Saudi kindergarten teachers' perceptions of the barriers to the successful inclusion of children with disabilities in kindergarten settings?

To answer this qualitative research question, thematic analysis was utilised. General and special education kindergarten teachers were asked to describe the perceived barriers to successfully including children with disabilities in their regular classrooms ($n = 8$). From their responses, there did not seem to be substantial differences in what the teachers perceived to be the barriers to inclusive education; they reported very similar barriers, whether they had a high or low level of self-efficacy or positive or less positive attitudes. Therefore, instead of dividing the teachers' responses based on their level of self-efficacy or attitudes, their responses were organised around nine key themes. These were: a lack of effective professional training, the need for special education teachers to teach children with disabilities that are outside of their specialisation, discrepancies in the salaries of special and general teachers, large class size, absence of special aides, a lack of collaboration between general and special education teachers, the nature and severity of the child's disability, an inappropriate physical environment, and a lack of support from Principals. These themes are discussed in order, from the most to the least frequently mentioned, in the following subsections.

8.3.5.1 A Lack of Effective Professional Training

The interview findings indicated that all the participants perceived a lack of effective professional training as a barrier to effectively teaching children with disabilities in an inclusive setting. Although many of the interview participants had participated in training sessions, courses, and workshops, they noted that these training programs had failed to

produce the desired outcomes. The teachers expressed the need to participate in well-designed and well-executed professional training programs that would enable them to incorporate new and improved practices into their inclusive classrooms. For example, Salma, a special education teacher, stated the following:

I received a number of in-service training sessions which were useless and cannot be applied in practice. We need training sessions that focus tightly on new and advanced teaching practices in inclusive classrooms, as what we are taught would then reflect practices that can actually make a negative or a positive difference for children learning in an inclusive setting.

Rana stressed the critical need for effective professional training on “collaborative teaching and the role of general and special education teachers in inclusive classrooms.” Moreover, Amal, who is a special education teacher and holds a master’s degree in special education, provided a rich and detailed response regarding the need for, and the importance of, providing pre- and in-service practical training for special and general education teachers on how to teach children with disabilities and support them as they participate in an inclusive classroom at the same level as their peers. The absence of such training can lead to unawareness among teachers—in particular, general education teachers—about the different types of disabilities their children struggle with, and can result in negative attitudes towards inclusive education in kindergarten settings:

As long as the Ministry of Education is supporting inclusive education, I see that all teachers must be provided with practical training courses on how to learn practical strategies and skills for teaching and supporting children with different types and severity of disabilities in inclusive classrooms. For example, where there are children with hearing disabilities included in the kindergarten, the Ministry of

Education must provide practical training courses on sign language for general education teachers and for special education teachers who are not specialised in hearing disabilities. Unfortunately, no general education teachers in this kindergarten have received an offer from the Ministry of Education to attend training sessions regarding the nature and severity of disabilities and inclusion. So, how we can ask general teachers to accommodate children with different types of disabilities and challenging behaviours in an inclusive classroom if there is basically no tendency to build teachers' understanding of the nature and causes of these disabilities and behaviours? Teachers must be provided with pre- and in-service professional training courses to build their practical ability to identify children's disabilities, distinguish between their different behaviours, adjust their practices to meet these children's learning needs, and address these children's challenging behaviour properly in an inclusive classroom. However, the teachers who lack knowledge of disabilities and inclusive education usually have negative perceptions towards children with disabilities and, in particular, towards including children with behavioural disorders in regular classrooms.

8.3.5.2 Discrepancies in General and Special Education Teachers' Salaries

All the interviewed participants pointed to the discrepancies between the salaries of general and special education teachers as an obvious barrier to implementing inclusive education. General education teachers have complained that special education teachers' basic salary can be up to 30% higher than that of general education teachers. In their opinion, general education teachers earn less despite taking on the responsibility of working with children with disabilities in inclusive classrooms. The interviewed participants suggested that this is a greater responsibility than that which special education teachers take on. In addition, the special education teachers asserted that the salary discrepancies pose a barrier

to the acceptance by general education teachers of working with children with disabilities in their regular classrooms. The issue of the salary discrepancy between general and special educators was captured best from a general education teacher's point of view when Sahar noted:

The differences between general and special education salaries and the lack of general teachers' incentives are the biggest barriers to inclusive programs. It is just unfair to work as a general teacher in an inclusive classroom with a large number of children with and without disabilities for the most of the day and then earn a salary that is 30% less than that of a special education teacher, who is not working with me in the same classroom for the most of the day and who is not collaborating in managing my inclusive classroom.

Additionally, Shahad, a special education teacher, asserted that these salary discrepancies discourage general education teachers from including children with disabilities in their regular classrooms and from collaborating with special education teachers:

I believe special and general salary inequity to be one of the other barriers that discourages general teachers from including children with disabilities in their classrooms and also from collaborating with me when I provide them with adapted instructions to implement in their inclusive classrooms.

8.3.5.3 Large Class Size

All the interview participants identified large class sizes as a barrier to effectively teaching children with disabilities in an inclusive classroom. They find large classes with 30 or more children, and including children with different types of disabilities, difficult to manage, preventing them from effectively focusing on children's individual needs and

requiring them to take the focus away from the children and the quality of the lessons.

According to Sahar, a general education teacher:

In my class, the number of children is 33; six of them have disabilities, and with this large number of children, it is very difficult to control and manage the class and the children' needs and to teach them effectively, especially when most of my time is wasted focusing on children with behavioural disorders.

Another participant, Amal, a special education teacher, added:

It has a huge impact on the children's learning if the number of children is too large! They do not pay attention to the teacher. Also, it increases the pressure on the teachers, especially with the absence of teacher aides and the lack of special education teachers.

8.3.5.4 Absence of Special Aides

The responses of all the interviewed teachers illustrate that the absence of special aides in inclusive classrooms is a barrier to the success of inclusive kindergarten classrooms. They discussed the need for teacher aides to support the involvement of children with disabilities in the classroom, to manage large class sizes, and to support individual children with disabilities. Dalal, a general education teacher, stated that "children with disabilities really need a one-to-one aide, and their inclusion is impossible to be implemented considering the absence of teacher aides and the large number of children in the classroom."

Salma, who is a special education teacher, also viewed the absence of teacher aides as a barrier to effective inclusive education. She added:

The absence of teacher aides is a serious barrier. How can we effectively implement inclusive programs in the regular classrooms without teacher aides and enough

special education teachers! Providing teacher aides will help teachers of large classes handle disruptions and monitor the class, which can help the teachers target the children who need additional help.

8.3.5.5 A Lack of Collaboration

The interviews revealed that seven of the eight teachers indicated a lack of collaboration between general and special education teachers as a major barrier to implementing inclusive education in kindergarten settings. Most of the general teachers indicated that special education teachers do not work in the same classroom for most of the day, and there is no direct collaboration or involvement between general and special education teachers with regard to teaching, planning, and managing classrooms. Dalal, a general education teacher, expressed the following:

I see that a key barrier to inclusive education in our kindergartens is the lack of collaboration between special education teachers and general teachers. She is not working with me in the same classroom most of the day; she is only there for 15 minutes in the circle time, as her current role is to take certain children with disabilities out for individual educational sessions in the resource room, which is located outside of the inclusive classroom; so, there is no cooperative teaching at all... She is not collaborative in managing the classroom and does not provide me with the right instructions by developing or adapting the teaching materials to meet and address the learning needs of each child with disabilities.

Shahad, a special education teacher, also identified the lack of collaboration between special and general education teachers as a barrier to successfully implementing inclusive education. She believes that general teachers do not wish to modify their practices, nor do they wish to collaborate with her and to follow the instructions she provides. She stated:

There is no collaboration between me and general education teachers. Most of them in this kindergarten are older than me and are looking for the easiest procedures to follow; they do not want to make any modifications or changes based on my adapted instructions within their inclusive classrooms, as they used to a certain teaching routine.

8.3.5.6 Nature and Severity of the Child's Disability

The interviews revealed that six of the eight teachers named the nature and severity of the child's disability as one of the most significant barriers to implementing successful inclusive education in a kindergarten setting. This is because the teachers felt that they were better equipped to manage some types of disabilities in their classrooms than others; for children with certain disabilities, the teachers felt that they could address these children's learning needs, whereas they found it difficult to meet the learning needs of students with other types of disabilities. For example, Moneerah, a special education teacher, remarked:

Including some children with severe disabilities, such as intellectual disabilities, autism, and behavioural disorders, is one of the greatest challenges we face in our inclusive kindergarten, because it is not an appropriate placement for them. I and other teachers are not qualified or trained to meet their learning needs in this inclusive setting, and I believe these children need to receive their learning and training in special kindergartens or centres where they will be in an appropriate environment with qualified specialists who can manage their behaviour and meet their learning needs.

Rana, a general education teacher, also noted the nature and the severity of a child's disability as a barrier to inclusive education in her current kindergarten setting. When discussing other teachers who have children with severe disabilities in their classrooms, she

said that “inclusive education is appropriate only for children with mild disabilities, such as physical, learning, and speech disabilities, and is never appropriate for children with moderate to severe disabilities, what with the current lack of inclusion support services.”

8.3.5.7 Inappropriate Physical Environment

Six out of the eight interviewed teachers indicated that an inappropriate physical environment is one of the significant barriers to the implementation of inclusive kindergarten classrooms. They indicated that their classrooms and kindergarten facilities do not support inclusion; some of kindergarten buildings are too old, have small doorways, have a poor layout and classroom spacing, or have no elevators or ramps. As Moneerah, a special education teacher, stated:

An inadequate physical and educational environment is also a significant barrier which the Ministry of Education should consider when implementing inclusive education. This kindergarten is not a welcoming environment for children with disabilities. It is out of order and has been for more than 15 years. Classrooms have small spaces and doorways, which do not allow any child with a walker or a wheelchair to pass through easily, and the toilets are not adapted for children with disabilities and are located far away from the classroom.

Sahar, a general education teacher, expressed the view that although her kindergarten building is new and designed to be an inclusive setting, it is not well-designed for children with behavioural and physical disabilities; she claims that it is not a safe environment where these children can feel accepted and welcome to participate in social and learning activities:

This kindergarten is new, built one year ago, and designed basically as an inclusive setting, but unfortunately, it has not been designed with safety in mind, especially

for children with behavioural disorders, whether indoors or outdoors. I did my best to organise and modify some things inside my classroom to keep them safe, but the space design itself needs to be redesigned. Also, there are corners inside the classrooms for presenting activities in certain areas (for example, art, maths, music, etc.). Each space was built and designed with an entry at each corner, but they are not accessible to children with wheelchairs. The outdoor play area is too small, and there are not enough pieces of equipment, which means that not every child is enabled to participate in play-based learning.

8.3.5.8 A Lack of Principal Support

Five of the eight interviewees perceived a lack of support from the Principal as a significant barrier to the success of inclusive education in a kindergarten setting. They complained that there was a lack of collaboration as well as a lack of knowledge about inclusive education and the needs of children with disabilities and teachers in inclusive classrooms on the part of their Principals. For example, Amal, a special education teacher, stated:

Kindergarten Principals are not cooperating with us because they are not aware of the practical concept of inclusion and how to deal with children with disabilities; they also do not give us freedom to deal with our children with disabilities, as they basically do not understand their special needs.

Sahar, a general education teacher, also perceived a lack of Principal support as a barrier. She noted her Principal's lack of knowledge about the role of teachers in inclusive settings and her Principal's poor leadership in considering the issues of inclusive education, asserting that the Principal did not provide the right support or direction for general or special education teachers:

Our Principal is another obstacle to the inclusive program. She does not know about inclusion, disabilities, or the right role for general and special education teachers in the inclusive classroom. For example, when I complained to her that the special education teacher is not taking the children with behavioural disorders to the individual educational sessions, as she does with the other children with disabilities, the Principal said me, “You are responsible for teaching and dealing with those children because they only have behavioural disorders.”

To sum up, all interview participants, whether they had a high or low levels of self-efficacy or positive or less positive attitudes, reported very similar barriers to including children with disabilities in their inclusive kindergarten. These barriers were a lack of effective professional training, the need for special education teachers to teach children with disabilities that are outside of their specialisation, discrepancies in the salaries of special and general education teachers, large class size, absence of special aides, a lack of collaboration between general and special education teachers, the nature and severity of the child’s disability, an inappropriate physical environment, and a lack of support from Principals.

8.4 Summary

This chapter has presented the interview participants' characteristics and the analysis of the findings of semi-structured interviews with eight kindergarten teachers. Four of these teachers were general education teachers and the remaining four were special education teachers, all employed in inclusive kindergartens in Riyadh, the capital city of Saudi Arabia. The aim of this analysis was to explore the factors influencing self-efficacy and attitudes of kindergarten teachers towards inclusive education in Saudi kindergarten settings and their perceptions of barriers to successfully including children with disabilities in their regular classrooms.

Key themes were evident from the thematic analysis. With respect to the third research aim and its related qualitative research question (3.7), factors influencing teachers' positive self-efficacy yielded four themes: teachers' passion and enthusiasm, encouragement from the Principal and parents, collaboration with special education teachers, and successful achievements of children with disabilities. Research question 3.7 also refers to factors influencing teachers' less positive self-efficacy, and in this respect three themes emerged: lack of knowledge and experience, lack of collaboration with the Principal and special education teachers, and teaching outside the area of specialisation. With respect to qualitative research question 3.8, regarding factors influencing teachers' positive attitudes, three themes emerged. These three themes were benefits for children with and without disabilities, empathy for the families of children with disabilities, and work-related enjoyment. Research question 3.8 also refers to factors influencing teachers' less positive attitudes, and this analysis yielded two themes: type and severity of disabilities and detrimental effects on children with and without disabilities.

With respect to the fourth research aim and its associated research question (4.1), reported barriers to inclusive education yielded nine themes. These themes were a lack of effective professional training, the need for special education teachers to teach children with disabilities that are outside of their specialisation, discrepancies in the salaries of special and general education teachers, large class size, absence of special aides, a lack of collaboration between general and special education teachers, the nature and severity of the child's disability, an inappropriate physical environment, and a lack of support from Principals. The following chapter will present the discussion of the quantitative and qualitative findings.

Chapter 9: Discussion of Findings, Recommendations, and Conclusions

9.1 Introduction

The purpose of this chapter is to discuss the key findings from both the questionnaire and interview data in relation to the main aims and questions of the study and examine these findings as they relate to previous empirical studies. The discussion covers the following topics: (1) validity and reliability of the Teacher Efficacy for Inclusive Practices (TEIP) scale and the Opinions Relative to the Integration of Students with Disabilities (ORI) scale; (2) levels of teachers' self-efficacy and attitudes, differences between general and special teachers, and the relationship between self-efficacy and attitudes; (3) factors influencing teacher's self-efficacy and attitudes towards inclusive education; and (4) teachers' perception of barriers to inclusive education. In addition, the chapter will present the strengths and limitations of the current study, implications for future research, and, importantly, recommendations for policy and practice.

9.2 Discussion of Findings

9.2.1 Validity and Reliability of the Adapted TEIP and ORI Scales

As discussed in Chapters 4 and 5, in order to measure Saudi kindergarten teachers' self-efficacy and attitudes towards inclusive education, this study used the adapted TEIP (Sharma et al., 2012) and ORI (Antonak & Larrivee, 1995) scales. The TEIP scale has been internationally validated and applied in Asian and Western contexts for measuring primary, secondary, and pre-services teachers' self-efficacy (Loreman et al., 2013; Savolainen et al., 2012; Yada et al., 2018), as well as kindergarten teachers' self-efficacy in inclusive education (Özokcu, 2018a, 2018b). In Saudi Arabia, the TEIP scale has been

successfully translated and validated for measuring Saudi primary and secondary school teachers' self-efficacy (Alnahdi, 2019c). Notably, the TEIP scale has not previously been utilised for measuring Saudi kindergarten teachers' self-efficacy in inclusive kindergarten education.

The ORI scale has also been internationally validated and applied in Egypt and Turkey (Emam & Mohamed, 2011; Özokcu, 2018b; Sari et al., 2009). Nationally, the scale has been successfully translated and validated for measuring Saudi primary and secondary school teachers' attitudes towards inclusive education (Adhabi, 2018; Al-Ahmadi, 2009; Alhudaithi, 2015; Alqahtani, 2017; Alquraini, 2011). Notably, this scale has not previously been utilised in Saudi inclusive kindergarten settings.

With the current study being the first study to use either of these scales in Saudi inclusive kindergarten settings, it was essential to examine whether the Arabic versions of the adapted TEIP and ORI scales are reliable and valid measures for the targeted population in this study. More specifically, the study was the first to address the following research questions:

- 1.1 How valid is the Teacher Efficacy for Inclusive Practices (TEIP) scale for measuring teachers' self-efficacy in the Saudi inclusive kindergarten context?
- 1.2 How reliable is the TEIP scale in the Saudi inclusive kindergarten context?
- 1.3 How valid is the Opinions Relative to the Integration of Students with Disabilities (ORI) scale for measuring teachers' attitudes in the Saudi inclusive kindergarten context?
- 1.4 How reliable is the ORI scale in the Saudi inclusive kindergarten context?

The results relevant to these research questions, and the implications of these findings, are discussed below.

9.2.1.1 Validity of the Adapted TEIP Scale

The content validity of the TEIP scale was determined and its appropriateness was confirmed by a group of experts before it was utilised (see Chapter 5). Confirmatory factor analysis (CFA) was used to determine the construct validity of the adapted TEIP scale and the indices and fit statistics from this analysis demonstrated its fit. The CFA was conducted many times. The initial CFA measurement models were conducted with all 18 items of the adapted TEIP scale, which resulted in six items with low factor loadings being removed from different latent constructs (items 15 and 18 from the Efficacy to use inclusive instructions [EII] factor; items 3 and 4 from the Efficacy in collaboration [EC] factor; and items 11 and 17 from the Efficacy in managing behaviour [EMB] factor (see Chapter 6). In the final CFA measurement model, however, the goodness-of-fit indices suggested that the measurement model of the adapted TEIP scale fit the data reasonably well and demonstrated that all 12 items had good correlations with their latent constructs of EII, EC, and EMB. Furthermore, the correlation values of the adapted TEIP latent constructs EII, EC, and EMB were measuring distinct latent constructs. These findings confirmed the two subtypes of construct validity—convergent validity and discriminant validity—of the current adapted TEIP scale.

In comparing these findings and those of earlier studies, a previous Saudi study by Alnahdi (2019c) validated the three-factor structure and the 18 items of the Arabic version of the TEIP scale and demonstrated acceptable psychometric properties with primary and secondary teachers (Alnahdi, 2019). However, the current findings cannot be fully comparable with the findings of this earlier study because of the differences between the two studies and the school levels. While Alnahdi (2019) demonstrated the validity of the Arabic version of the TEIP scale with Saudi pre- and in-service primary and secondary school teachers, this study is the first of its kind to demonstrate the validity of the adapted

TEIP scale in a Saudi inclusive kindergarten context with in-service teachers. The findings of the current study have demonstrated the construct validity of the adapted TEIP scale in this context and thus it provides future researchers with valuable information regarding the nature of the TEIP scale and its psychometric characteristics for measuring Saudi teachers' self-efficacy in inclusive kindergarten settings.

9.2.1.2 Reliability of the TEIP Scale

Results suggest that the Arabic version of the adapted TEIP scale with 12 items has good internal consistency across the total scores (.89) and its three individual factors: EII (.81), EC (.76), and EMB (.74) (see Chapter 6). In sum, the Arabic version of the adapted TEIP scale with 12 items reliably measures Saudi teachers' self-efficacy in inclusive education in Saudi kindergarten settings. The high value of Cronbach's alphas found for the adapted TEIP scale with 12 items in the present study are not comparable to those reported in the original study of TEIP (Sharma et al., 2012) or in previous international studies (e.g., Malinen et al., 2012; Savolainen et al., 2012; Yada & Savolainen, 2017). This is due to the differences in the context of school level and because all of these studies examined the reliability of the TEIP scale with all original 18 items. For example, Sharma et al. (2012) developed the TEIP scale to measure pre-service teachers' self-efficacy in inclusive practices and found that the reliability of the total TEIP scale with 18 items was 0.89, and the reliability of the factors EII, EC, and EMB were .93, .85 and .85 respectively.

Yada and Savolainen (2017) also examined the reliability of the TEIP scale with 18 items for Japanese primary and secondary teachers' self-efficacy. They found that the Cronbach's alpha of the total scale was .93, and the values for the factors ranged from .83 to .88. Furthermore, the coefficient alphas achieved in the current study are also not

comparable with Alnahdi's (2019c) study, which used the Arabic version of the TEIP with 18 items for in-service Saudi primary, secondary, and preservice teachers and indicated high reliability (total TEIP scale = .92; all three factors = .82). However, the findings of the current study have demonstrated the reliability of the Arabic version of the adapted TEIP scale with 12 items for measuring teachers' self-efficacy in inclusive education in Saudi kindergarten settings. These findings strengthen the current data and provide psychometric information on the adapted TEIP scale that can be used to support future research on teachers' self-efficacy in inclusive education in the kindergarten context.

9.2.1.3 Validity of the ORI Scale

The group of experts confirmed the content validity of the ORI scale before it was utilised (see Chapter 5). CFA was conducted to demonstrate the construct validity of the adapted ORI scale (Antonak & Larrivee, 1995) (see Chapter 6). As was the case for the adapted TEIP scale, CFA was performed many times. The initial CFA models were conducted with all 25 items of the adapted ORI scale, organised according to four a priori latent constructs: Benefits of integration (BI), Integrated classroom management (ICM), Perceived ability to teach children with disabilities (PA), and Special versus integrated general education teachers (SVG). This resulted in the removal of the factor PA which included items 2, 10, and 19. These items had very low factor loadings, high inter-correlations and they measured the same aspect of teachers' self-efficacy. In addition, there were six other items which were unacceptable because of their low factor loadings. Therefore, these were also removed from different latent constructs (items 20, 21, and 24 from BI; 4 and 12 from ICM; 8 from SVG) (see Chapter 6). The results of the final adapted CFA model indicated acceptable fit for the proposed scale structure and that all the remaining 15 items were reflective indicators of their respective latent constructs of the adapted ORI scale. Further examination of the correlation values of the adapted ORI

latent constructs BI, ICM, and SVG indicated that they were measuring distinct latent constructs, and all 15 items had good correlations with their latent constructs. These results demonstrated the two subtypes of construct validity—convergent validity and discriminant validity—were present in the current translated version of the adapted ORI scale with 15 items for measuring teachers’ attitudes towards inclusive education in Saudi kindergarten settings.

The current findings differ from the study by Emam and Mohamed (2011), which was conducted in Egypt and demonstrated the construct validity of all 25 items of the ORI scale for measuring kindergarten teachers’ attitudes toward inclusive education. Furthermore, the current findings are not comparable with the previous study in Saudi Arabia that examined the validity of the translated Arabic version of the ORI for measuring primary teachers’ attitudes towards inclusive education with children with a particular type of disability (e.g., Alasim & Paul, 2019; Alquraini, 2011). This is due to the differences in the statistical analysis used to measure the validity of the Arabic version of the ORI, as none of the other studies used CFA, as well as the differences in the school levels context. Thus, the findings of the current study demonstrated the construct validity of the translated and adapted ORI scale with 15 items using CFA in the Saudi inclusive kindergarten context. These findings provide researchers with valuable information regarding the psychometric characteristics of the ORI scale (Antonak & Larrivee, 1995) for measuring teachers’ attitudes towards inclusive education in Saudi kindergarten settings.

9.2.1.4 Reliability of the ORI Scale

The reliability coefficients for the overall adapted ORI scale with 15 items and its three factors—Benefits of integration (BI), Integrated classroom management (ICM) and Special versus integrated general education teachers (SVG)—were .89, .72, .68, and .62, respectively (see Chapter 6). This suggests that the adapted ORI scale with 15 items has acceptable internal consistency across the total scale and the three individual factors (BI, ICM, and SVG) (Field, 2017). Due to the differences in the overall number of original items from the ORI scale used in this study, the current findings about the reliability of the adapted ORI scale with 15 items are not comparable to Emam and Mohamed's (2011) study that demonstrated the reliability of the ORI scale with 25 items for measuring Egyptian kindergarten teachers' attitudes. In addition, the present findings also cannot be compared with those reported in the original study of the reliability of the original ORI scale with 25 items (Antonak & Larrivee, 1995), or with other studies that used the Arabic version of the ORI scale for measuring primary teachers' attitudes (e.g., Adhabi, 2018; Alasim & Paul, 2019; Alquraini, 2011). This is because of the differences in the school levels context and because all of these studies examined the reliability of the ORI scale with all original 25 items. Thus, this study is the first of its kind to demonstrate the reliability of the adapted ORI scale in a Saudi inclusive kindergarten context. The findings of the current study confirm the reliability of the translated and adapted ORI scale with 15 items for measuring teachers' attitudes towards inclusive education in Saudi kindergarten settings.

9.2.2 Levels Of Teachers' Self-Efficacy and Attitudes, Differences Between General and Special Education Teachers, and the Relationship Between Self-Efficacy and Attitudes

The following sections present and critically discuss key findings from the quantitative analysis of the questionnaire. Key findings relate to the level of teachers' self-efficacy, teachers' attitudes, the differences between general and special education teachers, and the relationship between teachers' self-efficacy and attitudes. The key findings thus contribute to answering the following research questions:

- 2.1 What are Saudi Kindergarten teachers' levels of self-efficacy towards inclusive education as measured by Teacher Efficacy for Inclusive Practices (TEIP)?
- 2.2 What are Saudi kindergarten teachers' attitudes towards inclusive education settings as measured by Opinions Relative to the Integration of Students with Disabilities (ORI)?
- 2.3 What is the difference between Saudi general education and special education teachers' self-efficacy in inclusive education in kindergarten settings?
- 2.4 What is the difference between Saudi general education and special education teachers' attitudes towards inclusive education in kindergarten settings?
- 2.5 What is the relationship between Saudi teachers' self-efficacy and attitudes towards inclusive education in kindergarten settings?

9.2.2.1 Teachers' Self-efficacy in Inclusive Education

The results of the quantitative analysis of the overall levels of self-efficacy demonstrated by Saudi teachers through the adapted TEIP scale indicated that the teachers generally had somewhat positive self-efficacy in inclusive education in kindergarten settings. On a 5-point Likert-type scale the mean was 3.86, which is close to 4 (agree) (see Chapter 7). It is worth noting that there is limited research examining kindergarten teachers' self-efficacy in inclusive education worldwide (Francois, 2020), and no previous studies

have examined Saudi kindergarten teachers' self-efficacy in inclusive education. Therefore, the current findings of this study can be compared to only a few existing studies that utilised the TEIP scale for examining kindergarten teachers' self-efficacy in inclusive education. For example, this finding is consistent with two studies regarding kindergarten teachers' self-efficacy in inclusive education that both used the TEIP scale and found Turkish teachers generally had somewhat positive self-efficacy in inclusive education (Özokcu, 2018a; Sari et al., 2009). It is also consistent with a Saudi study that examined primary and secondary teachers' self-efficacy in inclusive education using the TEIP scale (Alnahdi, 2019a).

Furthermore, the results of the current study also demonstrated that teachers have a higher level of self-efficacy on the TEIP factors of using inclusive instructions (EII; $M = 3.91$) and collaboration (EC; $M = 3.90$) compared with managing children's behaviour in the inclusive classroom factor (EMB; $M = 3.78$). The current findings are inconsistent with the findings of Özokcu (2018a), who found that Turkish kindergarten teachers had a higher level of self-efficacy on the EMB factor and the lowest level of self-efficacy on the EC factor. The inconsistency between the results of this study and Özokcu's (2018a) findings could be attributed to the potential differences in socio-economic and cultural circumstances and inclusive educational practices between Saudi Arabia and Turkey. However, the current findings of this study are consistent with Alnahdi's (2019a) findings that found Saudi primary and secondary teachers had higher self-efficacy in the EII factor than in the EC or EMB factors. This consistency may reflect that Saudi teachers may generally tend to have higher self-efficacy in using inclusive instructions, and lower self-efficacy in collaboration and managing the behaviour of children with disabilities. According to Alnahdi (2019a), this may be due to the lack of teamwork in Saudi schools, with most work done by classroom teachers as well as a lack of advanced skills that some teachers might have regarding children with disabilities and managing their behaviour in inclusive classrooms.

9.2.2.2 Differences Between Self-efficacy of Special and General Education

Teachers

The findings of the current study demonstrated that special education teachers had higher self-efficacy as measured by the total TEIP score and the three factors than general education teachers, who also had a high level of self-efficacy (see Chapter 7). The current result is consistent with only one other study's findings: Wang et al. (2012) found that Chinese primary and secondary special education teachers had higher self-efficacy in inclusive education than general education teachers. However, in Saudi Arabia, no previous studies have examined the differences between general and special education teachers' self-efficacy in inclusive education at any school level. The higher levels of self-efficacy of special education teachers found in the present study could be a result of these teachers engaging more in study through their specialisation in special education and having greater knowledge of children with disabilities and inclusive education than their general education counterparts. In contrast, general education teachers, due to a lack of specialised training, might be less knowledgeable and less aware of children with different types of disabilities and the implementation of inclusive education practices. These findings advance the understanding of special and general education teachers' self-efficacy in inclusive education in kindergarten settings. They also contribute to the limited literature examining such differences.

9.2.2.3 Teachers' Attitudes Towards Inclusive Education

In this study, total scores on the ORI scale indicated that Saudi kindergarten teachers had generally neutral attitudes towards inclusive education with a mean of 3.20, which is slightly above neutral on a 5-point Likert-type scale (see Chapter 7). This result is consistent with Sari et al.'s (2009) findings that Turkish kindergarten teachers' total score on the ORI scale showed a neutral attitude towards inclusive education. It is also consistent with another

Turkish study's finding, in which the total ORI scores demonstrating kindergarten teachers' attitudes towards inclusive education were also found to be neither positive nor negative (Özokcu, 2018b). However, the current findings of the overall generally neutral kindergarten teacher attitudes are inconsistent with previous international studies that examined kindergarten teachers' attitudes towards inclusive education using different attitudes scales and found the teachers generally held positive attitudes toward inclusive education (Fakih, 2019; Hsieh & Hsieh, 2012; Hussain, 2017; Štemberger & Kiswarday, 2018).

Notably, no previous empirical research has been conducted to examine kindergarten teachers' attitudes towards inclusive education in Saudi Arabia. However, there are a number of studies that have examined the attitudes of primary and secondary teachers, and the combination of negative (Alquraini 2011;2012; Aseery, 2016), neutral (Alasim & Paul, 2019), and positive (Alamri, 2014; Alhudaithi, 2015) attitudes varied depending on the specific type of students' disability that was the focus of their studies. Thus, the findings of the current study contribute to the field of inclusive education by advancing knowledge about Saudi kindergarten teachers' attitudes towards including all children with different types of disabilities.

Furthermore, the current results also showed that kindergarten teachers tended to have positive attitudes regarding the Benefits of integration (BI) factor, while they tended to have more negative attitudes toward the Integrated classroom management (ICM) factor than the Special versus integrated general education (SVG) factor. None of the previous international studies (Sari et al., 2009; Sucuoğlu et al., 2013) used the factor scores of the ORI scale to measure kindergarten teachers' attitudes towards inclusive education as they only used the total score of the ORI scale, as discussed above. Thus, the current findings for

the ORI factors seem to be broadly consistent with other research that has used the ORI scale to measure Saudi secondary and primary teachers' attitudes toward including deaf and hard-of-hearing students in regular classrooms in Saudi Arabia. That study found that Saudi teachers' attitudes toward the BI factor were the most positive, while their attitudes were the least positive towards the ICM factor (Aseery, 2016). The findings of the current study can be attributed to the evidence from reviews (e.g., Avramidis & Norwich, 2002) and other Saudi studies (Al-quraini, 2011; Aseery, 2016) that suggests teachers generally tend to hold positive attitudes towards the concepts and benefits of inclusive education but less positive or negative attitudes at the implementation level.

9.2.2.4 Differences Between Attitudes of Special and General Education

Teachers

Regarding the differences between the attitudes of Saudi kindergarten general and special education teachers, the results showed that special education teachers had more positive attitudes (indicated by the total ORI score and the three factors) than general education teachers, who also had positive attitudes. This finding supports Maiorca-Nunez (2017), who found that kindergarten special education teachers in the United States had more positive attitudes towards inclusive practices than did kindergarten general education teachers. However, the results differ from Hussain's (2017) study, in which no differences were found between the attitudes of kindergarten special and general education teachers in United Arab Emirates towards inclusive education (both groups in that study demonstrated similarly positive attitudes).

To contrast the current findings with the previous studies in Saudi Arabia, it is worth noting that there have been no previous studies that have examined kindergarten teachers' attitudes or the differences between special or general education teachers; however, there

are a small number of Saudi studies that have examined the attitudes of primary and secondary special and general education teachers towards inclusive education. For example, Alhudaithi's (2015) findings are broadly consistent with the findings of this study, in which primary special education teachers had more positive attitudes than general education teachers towards including children with autism spectrum disorder in regular classrooms. In other studies, no significant differences were found between primary general and special education teachers' attitudes towards including children with specific types of disabilities in regular classrooms (Adhabi, 2018; Alasim & Paul 2019). In light of these findings, the more positive attitudes towards inclusive education held by Saudi special education teachers than general education teachers either in primary or kindergarten settings could be interpreted as a result of their specialising in special education and having greater knowledge of children with disabilities and inclusive education; in contrast, general education teachers might have a less comprehensive picture and less awareness of children with different types of disabilities and the implementation of inclusive education practices.

9.2.2.5 Relationships Between Teachers' Self-Efficacy and Attitudes

The correlation coefficients calculated for this study revealed that every relationship between Saudi kindergarten teachers' self-efficacy and attitudes on the TEIP and ORI factors was significantly and strongly positively correlated. Similar findings have been reported in previous research in other countries, which demonstrated a positive, significant relationship between kindergarten teachers' attitudes and self-efficacy in regard to inclusive education (Emam & Mohamed, 2011; Özokcu, 2018b; Sari et al., 2009). In Saudi Arabia, however, only one study has examined the relationship between teachers' attitudes and self-efficacy in including students with AD/HD-related behaviours in Saudi primary schools. The findings of that study further support the current study by indicating a positive and

strong relationship between teachers' attitudes and their self-efficacy in the inclusion of such students (Alamri, 2014).

The current study found the highest positive correlation was between teachers' self-efficacy in collaboration (the EC factor of TEIP) and teachers' attitudes (the three ORI factors). This result is consistent with those of other studies in the field, including Malinen et al. (2012), Özokcu (2018b), and Rahayu and Kurniawati (2019). This result implies that teachers' self-efficacy in collaborating with colleagues and parents in an inclusive setting has a significant positive association with their attitudes towards inclusive education. This is in line with the literature review of teachers' attitudes towards inclusive education by Avramidis & Norwich (2002), which concluded that the greater teachers' self-efficacy in collaboration to support the needs of students with disabilities in inclusive settings, the more positive attitudes they hold towards including such students in their regular classrooms.

The results above are further supported by the theory of planned behaviour, which states that, the more positive self-efficacy (perceived behavioural control) and attitudes one has toward a particular behaviour, the greater one's intention is to perform that behaviour (Ajzen, 1991). This implies that teachers with high self-efficacy and positive attitudes toward the inclusion of children with disabilities will demonstrate more positive inclusionary behaviours, which will, in turn, support the learning environment for these children. On the other hand, teachers with low self-efficacy and negative attitudes toward the inclusion of such children will likely exhibit negative inclusionary behaviours, which may exclude and discriminate against these children.

9.2.3 Factors Influencing Teacher's Self-Efficacy and Attitudes Towards Inclusive

Education

The following sections present and critically discuss key findings emerging from the questionnaire quantitative analysis and the qualitative analysis of interview data. Key findings relate to teacher-related factors, child-related factors, and context-related factors influencing teacher's self-efficacy and attitudes towards inclusive education. The theory of planned behaviour (Ajzen, 1991) acknowledges the significance of the influence of background factors (teacher-related factors) on shaping teachers' self-efficacy and attitude towards performing the behaviour of interest (including children with disabilities in their classroom. On the other hand, the ecological system theory (Bronfenbrenner, 2009) helps explain the influence of child and context related factors and barriers to inclusive education which are represented in different types of environmental systems and how they are responsible for shaping and influencing the self-efficacy and attitudes of kindergarten teachers. Thus, the key findings relate to these factors contribute to answering the following research questions:

- 3.1 How do **teacher-related** factors (age; teaching position; years of teaching experience in general education; years of teaching experience in special education; years of teaching experience in inclusive education; training about children with disabilities or in inclusive education; having a family member, close relative, or friend with a disability) **influence teacher self-efficacy** in inclusive Saudi kindergarten settings?
- 3.2 How do **teacher-related** factors (age; teaching position; years of teaching experience in general education; years of teaching experience in special education; years of teaching experience in inclusive education; training about children with disabilities or

in inclusive education; having a family member, close relative, or friend with a disability) **influence teacher attitudes** towards inclusive education in Saudi kindergarten settings?

3.3 What is teachers' self-efficacy regarding the inclusion of **children with specific types of disabilities** in Saudi kindergarten settings? (child-related factor)

3.4 What are teachers' attitudes towards the inclusion of **children with specific types of disabilities** in Saudi kindergarten settings? (child-related factor)

3.5 How do **context-related** factors (class size and number of special education teachers) influence Saudi **teachers' self-efficacy** in inclusive kindergarten settings?

3.6 How do **context-related** factors (class size and number of special education teachers) influence Saudi **teachers' attitudes** towards inclusive education in kindergarten settings?

3.7 What are the reported factors influencing Saudi general and special education teachers' self-efficacy in inclusive education in Saudi kindergarten settings?

3.8 What are the reported factors influencing Saudi general and special education teachers' attitudes towards inclusive education in Saudi kindergarten settings?

9.2.3.1 Factors Influencing Teacher's Self-Efficacy in Inclusive Education

9.2.3.1.1 Teacher-related Factors

Teachers' age and self-efficacy. In the quantitative data, results of the multiple regression showed that a teacher's age was a significant negative predictor of the total level of that teacher's self-efficacy on the overall TEIP scale and on the two factors of EC and EMB. This means that the younger teachers are, the higher their levels of self-efficacy in inclusive education.

A possible explanation for this finding might be that inclusive education has recently been introduced into teacher education programs in Saudi Arabia (Alquraini & Rao, 2018), and younger teachers could have a better understanding of inclusive education. As result, they might feel more confident in their abilities to teach in inclusive settings, while older teachers might not feel sufficiently educated about inclusive education.

In regard to the interview findings of this study, teachers' age did not come up as a theme because none of the eight participants mentioned that a teacher's age might influence their self-efficacy in inclusive education.

The significant influence of teachers' age on their self-efficacy demonstrated in this study's quantitative analysis is inconsistent with the few previous studies in other countries that have examined the relationship between kindergarten teachers' age and their self-efficacy in inclusive education. In Turkey, Özokcu (2018a) found that a teacher's age had no influence on their total level of self-efficacy on the TEIP scale or on its three factors. Furthermore, You et al. (2019) found that there was no significant relationship between Korean kindergarten teachers' age and their self-efficacy in inclusive education using a different self-efficacy measurement scale. However, in Saudi Arabia, no studies have previously examined the association between teachers' age and self-efficacy in inclusive education, either in kindergarten or primary and secondary settings, meaning this study is the first to do so.

Teaching position and self-efficacy. The results of this study's multiple regression analysis showed that teaching position (special or general education teacher) was a significant positive predictor of the total level of teachers' self-efficacy on the TEIP scale and its EII and EC factors. Specifically, this result showed special education teachers' self-efficacy was higher than that of general education teachers. As previously mentioned, this

could be interpreted as a result of these teachers specialising in special education and having greater knowledge of children with disabilities and inclusive education, whereas general education teachers might not have such knowledge and awareness. The current result is consistent with Wang et al. (2012), in which Chinese primary and secondary special education teachers had higher self-efficacy in inclusive education than general education teachers.

Notably, neither the influence of teaching position on kindergarten teachers' self-efficacy nor the differences between the level of self-efficacy of special and general education teachers in inclusive education have been examined in previous international studies, including those conducted in Saudi Arabia. As result, this study provides some preliminary empirical evidence for the argument that teaching position does seem to influence kindergarten teachers' self-efficacy regarding inclusive education.

Years of teaching experience and self-efficacy. In the present study, the findings of the multiple regression showed that years of teaching experience in either a general education, special education, or inclusive education setting had no significant influence on Saudi kindergarten teachers' self-efficacy in inclusive education. Findings from previous international literature regarding the influence of this factor are inconsistent with the findings of the current study. Earlier studies showed that more years of teaching experience were associated with kindergarten teachers' positive self-efficacy in inclusive education (Emam & Mohamed, 2011; You et al., 2019; Özokcu, 2018a). In Saudi Arabia, however, there is no previous research that examines the influence of teaching experience on self-efficacy in inclusive education in any school setting, including kindergarten. The inconsistency between the findings of this study and those of previous international research may be attributed to the differences in the statistical tests used, the context of Saudi Arabia, or the types of experiences that teachers have had with children with different types disabilities.

Teachers' training and self-efficacy. In the current study, the interview findings helped develop a further understanding of the influence of training about inclusive education on Saudi kindergarten teachers' self-efficacy in inclusive education. In the interviews, teachers who showed less positive self-efficacy in the questionnaire data revealed a lack of confidence in their abilities to work in inclusive classrooms due to their lack of training and knowledge about inclusive education. These teachers acknowledged their need for practical training courses about inclusive education and believed that such training was necessary to build their efficacy in meeting the learning needs of children with different types of disabilities in inclusive classrooms.

Despite teachers acknowledging the importance of training about inclusive education in the interviews, the quantitative multiple regression findings showed that teacher training about inclusive education had no significant influence on teacher's self-efficacy in inclusive education. This finding is inconsistent with previous international studies, which have found a positive correlation between teacher training and self-efficacy, and have reported that kindergarten teachers with inclusive education training had higher self-efficacy than other teachers without such training (Özokcu, 2018a; You et al., 2019). In Saudi Arabia, however, there is only one study that examined the influence of teacher training on the self-efficacy of primary teachers in including students with AD/HD-related behaviours in their regular classroom. It showed that teacher training had a significant influence on teachers' self-efficacy regarding the inclusion of students with AD/HD-related behaviours and reported that teachers with a lack of training did not feel confident in working with these students in their regular classrooms (Alamri, 2014). The discrepancy between the findings of the current study and the findings of previous studies could be attributed to the differences in the level of school settings, types of analytical tests used, and the type and extent of data on training about inclusive education.

Having a family member, close relative, or friend with a disability and self-efficacy. The findings of the current study showed that having a family member, close relative, or friend with a disability had no significant influence on Saudi kindergarten teachers' self-efficacy in inclusive education. It is worth noting that only a limited number of previous studies internationally have investigated the influence of this factor on kindergarten teachers' self-efficacy, and none in Saudi Arabia have done so. For example, the findings of the current study are consistent with the findings of Özokcu (2018a), who found that social contact with individuals with disabilities had no significant effect on Turkish kindergarten teachers' self-efficacy in inclusive education.

In the interview findings of the current study, none of teachers indicated the influence of having a family member, close relative, or friend with a disability on their self-efficacy in inclusive education. Thus, this factor did not appear to influence Saudi kindergarten teachers' self-efficacy in inclusive education.

Teachers' passion and enthusiasm and self-efficacy. The interview findings showed that teachers' passion and enthusiasm was an important influence on kindergarten teachers' positive self-efficacy in inclusive education. The teachers revealed that passion for teaching and enthusiasm to learn, gain new knowledge, and develop their teaching skills can result in increased confidence and a feeling of comfort in working with children with disabilities in regular classrooms. Notably, there is a lack of research studies in the inclusive education context regarding the influence of teachers' enthusiasm and passion on teachers' self-efficacy. Therefore, the current findings will enhance understanding about the influence of teachers' affective states (i.e., passion and enthusiasm) on kindergarten teachers' self-efficacy in inclusive education. Given the absence of relevant previous research in the inclusive education context, the present findings are compared with those from general educational settings. For example, Kim's (2017) study suggested the positive effect of teachers' passion on kindergarten teachers' self-efficacy. In addition, there are a number of studies supporting the positive influence of teachers' enthusiasm on their self-efficacy (e.g., Burić & Moè, 2020; Salanova et al., 2011). In general, being passionate and enthusiastic about teaching can be a resourceful factor for enhancing teacher's self-efficacy and improving learning outcomes in inclusive classrooms.

Teaching outside the area of specialisation and self-efficacy. The interview findings indicated that teaching outside the area of specialisation is a factor that may foster lower self-efficacy among special education teachers. The findings suggest that teaching

children with specific types of disabilities that are different from the special education teacher's area of specialisation challenges their ability to manage and address the needs of children with different types of disabilities, and affects their confidence in teaching. This, as a result, negatively influences special education teachers' self-efficacy and the development and learning of children with disabilities.

The negative impacts of this factor match those observed in international literature, which show that teachers who teach outside their area of specialisation feel frustrated and struggle, affecting their confidence in their ability to effectively meet the unique learning needs of children and to do so in a timely manner, because of their lack of context-specific skills and pedagogical content knowledge (Du Plessis, 2019). In Saudi Arabia, the influence of teaching outside the area of specialisation has not been discussed due to the lack of previous studies on teachers' self-efficacy in inclusive education. Thus, recommendations of this study may be useful in helping to address this issue.

9.2.3.1.2 Child-Related Factors

Types of disabilities and self-efficacy. In the current study, kindergarten teachers were asked to rank specific types of disabilities (behavioural disorders and autism, intellectual disabilities, hearing disabilities, learning disabilities, speech and language disabilities, visual disabilities, physical disabilities, and multiple disabilities) based on how confident they felt about including children with these specific types of disabilities in their classrooms. The questionnaire findings showed that Saudi kindergarten teachers were most confident in including children with speech and language disorders in regular classrooms, followed by children with physical disabilities, while they were least confident in including children with multiple disabilities followed by behavioural disorders and autism.

It should be pointed out that empirical evidence regarding the association between types of disabilities and teachers' self-efficacy in inclusive education in kindergarten settings is limited; only a few studies in primary and secondary settings have examined the relationship between teachers' self-efficacy and the type of disability and its severity (Hofman & Kilimo, 2014; Yada & Savolainen, 2019). Before the current study, no evidence had previously existed for the kindergarten setting. The study that Hofman and Kilimo (2014) conducted in primary schools in Tanzania found no significant relationship between teachers' self-efficacy and the children's type of disability or its severity (Hofman & Kilimo, 2014). However, Yada and Savolainen (2019) found positive correlations between Japanese and Finnish primary and secondary teachers' high self-efficacy and perceptions of students with moderate disabilities, and a negative correlation with perceptions of students with severe disabilities. These findings are not comparable to the findings of current study due to the differences in the analysis methods and research settings. In Saudi Arabia, however,

no previous studies have investigated the association between the type of disability and teachers' self-efficacy in inclusive education. Therefore, the current study provides some novel empirical evidence for consideration.

The interview findings of the current study provided further understanding of this issue, with special education teachers who specialised in hearing disabilities expressing their lack of self-efficacy in teaching children with other specific types of disabilities that were out of their area of specialisation (e.g., children with intellectual disabilities and autism). However, other special education teachers expressed confidence in their ability to teach and support children with all types of disabilities in the inclusive kindergarten setting due to their satisfaction with the successful end-of-year progress and achievements of children they had taught in the past.

9.2.3.1.3 Context-related Factors

Class size and self-efficacy. In the current study, results of the multiple regression showed that class size was a significant negative predictor of the total level of teachers' self-efficacy as measured on the TEIP scale and on its three factors. This indicates that as the number of children in the classroom increases, the teachers' level of self-efficacy decreases.

It is worth noting that this study has demonstrated, for the first time, some novel empirical evidence on the influence of class size on teacher's self-efficacy in inclusive education nationally and internationally, because this factor has not been examined in previous studies of inclusive contexts.

The significant influence of class size on Saudi kindergarten teachers' self-efficacy can be further explained by the interview findings of the current study, which suggested that class sizes act as a barrier to inclusive education (rather than a factor influencing teachers' self-efficacy or attitudes). In the interviews, all teachers discussed the negative influence of large class sizes when they were asked about their perceived barriers to implementing successful inclusive education in the kindergarten setting. They revealed that a large class was a barrier to effectively teaching and addressing the needs of children with disabilities in inclusive classrooms. A more comprehensive discussion of this negative influence is provided in section 9.3 of this chapter.

Number of special education teachers and self-efficacy. The findings of the multiple regression in the current study showed that the number of special education teachers in Saudi inclusive kindergartens had no significant influence on kindergarten teachers' self-efficacy in inclusive education. It is worth noting that no international studies have investigated the influence of this factor on kindergarten teachers' self-efficacy in inclusive education. Similarly, in Saudi Arabia, no studies have examined this association in primary or secondary settings.

The interview findings of the current study supported the questionnaire findings in this regard, as none of the interview participants indicated the influence of the number of special education teachers on their self-efficacy in inclusive education. Thus, it can be concluded that this factor did not affect Saudi kindergarten teachers' self-efficacy in inclusive education.

Encouragement from the Principal and self-efficacy. The interview findings showed that encouragement from Principals is a factor that can influence kindergarten teachers' positive self-efficacy in inclusive education. Interviews revealed that encouragement from the Principal and a strong trust relationship between the Principal and the teacher had a great influence on building the kindergarten teacher's self-efficacy and feelings of success in working in an inclusive setting.

There has been limited research in the inclusive education context on the influence of Principals' encouragement on teachers' self-efficacy. Therefore, the current findings are compared with educational studies in general. A review of research studies on the influence of Principals' supportive leadership on teachers' self-efficacy indicates that there is a significant positive effect of principals' supportive leadership behaviours on enhancing

teachers' sense of self-efficacy in teaching (Francisco, 2019; Liu & Gumah, 2020; Mehdinezhad & Mansouri, 2016). This suggests that an understanding of the positive effect of Principals' encouragement on enhancing teacher's self-efficacy in inclusive education is necessary to promote successful inclusive educational practices in Saudi kindergarten settings.

Collaboration between teachers and self-efficacy. The interview findings suggested that the collaboration of teachers is crucial in fostering or hindering teachers' self-efficacy in inclusive education. In the interviews, a general education teacher with positive self-efficacy revealed that the collaboration and support she gets from special education teachers has a great influence on raising her confidence in her ability to work with children with disabilities in her regular classroom. Conversely, another general education teacher with lower self-efficacy discussed her experience of a lack of collaboration with the special education teachers. These results suggest that collaboration between special and general education teachers is essential in fostering teachers' self-efficacy in inclusive education, and expand the few previous studies that have supported the importance of collaboration among special and general education teachers in increasing their levels of self-efficacy (e.g., Daniels, 2018; Malinen et al., 2012; Savolainen et al., 2012). Thus, the more collaboration that general and special education teachers obtain from each other, the higher their self-efficacy will become, which in turn will improve inclusive education outcomes.

9.2.3.2 Factors Influencing Teachers' Attitudes Towards Inclusive Education

9.2.3.2.1 Teacher-related Factors

Teachers' age and attitudes. The current study's multiple regression results showed that teachers' age was not a significant predictor of their total attitude level on the ORI scale or its three factors (BI, ICM, and SVG).

This finding of the non-significant influence of teachers' age on their overall attitudes towards inclusive education is consistent with the limited previous international studies in kindergarten settings, which showed that a teacher's age did not have any significant effect on their overall attitude (using different attitudinal instruments) towards inclusive education (Parasuram, 2006; You et al., 2019). In Saudi Arabia, however, as already mentioned, no studies have investigated teachers' attitudes towards inclusive education in kindergarten settings; thus, the current finding can only be compared to Saudi studies on teachers' attitudes towards including children with specific types of disabilities in a regular primary setting (Adhabi, 2018; Al-Ahmadi, 2009; Alamri, 2014). The findings of Adhabi (2018) showed no significant effect of age on primary teachers' total attitude level on the ORI scale, or on its three factors. Other Saudi studies also found no relationship between the age of teachers and their overall attitudes (using different attitudinal instruments) towards including students with learning disabilities and students with AD/HD-related behaviours (Al-Ahmadi, 2009; Alamri, 2014).

The interview findings of the current study also did not provide any evidence that age may influence a teacher's attitude towards inclusive education. Thus, it seems this factor did not affect Saudi kindergarten teachers' attitudes towards inclusive education.

Teaching position and attitudes. The results of the multiple regression in the current study showed that teaching position had a significant positive influence on the overall level of teachers' attitudes on the ORI scale, with special education teachers' attitudes more positive than those of general education teachers.

The results of current study are inconsistent with previous international research studies in kindergarten settings which have found teaching positions not to be a significant influence on attitudes. For example, Hussain (2017) found no significant relationship between the teaching position and kindergarten teachers' overall attitudes towards inclusive education. In Saudi Arabia, however, the current results are consistent with the findings of Alhudaithi (2015), Alquraini (2011), and Alqahtani (2017), which found a significant relationship between teaching position and overall attitudes towards inclusive education and showed that special education teachers had more positive attitudes towards inclusive education than general education teachers in primary schools.

These results may highlight the differences between Saudi special and general education teachers' specialisation, knowledge, and awareness regarding including children with disabilities in inclusive kindergarten settings.

Years of teaching experience and attitudes. In the present study, the multiple regression results indicated that years of teaching experience in inclusive education had a significant positive influence on the overall level of teacher's attitudes on the ORI scale and its SVG factor. This means as teachers' years of teaching experience in inclusive education increase, their attitudes become more positive.

This finding is consistent with the previous international studies in kindergarten settings that found a positive correlation between teachers' years in inclusive education and their overall attitude towards inclusive education (Emam & Mohamed, 2011; You et al., 2019). However, the finding of the current study is inconsistent with other international studies in kindergarten settings that found that teachers' years of experience in inclusive education had no significant effect on their attitudes (Dias & Cadime, 2016; Štemberger and Kiswarday, 2018).

In Saudi Arabia, Adhabi (2018) showed that Saudi primary teachers' years of experiences was a significant predictor of their overall negative attitudes, as measured with the ORI, and their scores on its SVG factor: as years of teaching experience increased, teachers' attitudes towards inclusion of students with autism spectrum disorder became more negative. However, Alamri (2014), Alasim and Paul (2019), and Aseery (2016) reported that there was no correlation between Saudi primary teachers' years of experience and their overall attitudes towards including students with specific types of disabilities in regular classrooms. The discrepancies between the findings of these previous Saudi studies and the current study might be due to the differences in the types of experience that teachers were asked about, as in those studies teachers were asked about their years of experiences

in general, whereas in the current study teachers were asked more specifically about their years of experiences in general, special, and inclusive education.

Notably, the interview findings of the current study did not reveal the influence of years of experience in inclusive education on interviewed teachers' attitudes towards inclusive education. Thus, based on the quantitative findings, the present study may suggest that as Saudi kindergarten teachers gain more experience in inclusive education, they are more likely to be more positive and supportive of inclusive education.

Teachers' training and attitudes. The findings of the multiple regression in the current study showed that teachers' training about children with disabilities or in inclusive education had no significant influence on Saudi kindergarten teachers' attitudes towards inclusive education.

This finding from the questionnaire data is inconsistent with other international studies conducted in kindergarten settings, which have found that training about inclusive education has a significant influence on kindergarten teachers' attitudes towards inclusive education (Batu et al., 2017; Fakhri, 2019; Lee et al., 2015; You et al., 2019). Some of these studies were quantitative and found that kindergarten teachers with pre- or in-service training about inclusive education had more positive attitudes towards inclusive education than teachers without such training (Lee et al., 2015; You et al., 2019). However, other qualitative and mixed-methods studies demonstrated that although kindergarten teachers had positive attitudes towards inclusive education, they had insufficient knowledge about working with children with disabilities in inclusive settings due to a lack of pre- and in-service training (Batu et al., 2017; Fakhri, 2019).

Moreover, in Saudi Arabia, the findings of previous studies in primary settings are also inconsistent with the present study's findings; these studies indicated that teacher

training about inclusive education has a significant influence on Saudi primary teachers' attitudes towards including students with specific disabilities in their regular classrooms (Adhabi, 2018; Alamri 2014; Aseery, 2016). The discrepancy between the present study's findings and previous studies could be attributed to the differences in the statistical analysis and in the school-level-context, and whether attitudes were towards the inclusion of children with all types of disabilities, or with specific disabilities.

In the interview findings of the current study, none of the teachers discussed the influence of training on their attitudes towards including children with disabilities in regular classrooms. However, when they were asked about the perceived barriers to successfully including children with disabilities in their regular classrooms, they elaborated on a lack of professional training as a barrier to effectively teaching and working with children with different types of disabilities in inclusive kindergarten settings, as well as their need for effective practical training courses (see section 9.3 of this chapter).

Having a family member, close relative, or friend with a disability and attitudes.

The findings of the multiple regression in the present study indicated that having a family member, close relative, or friend with a disability had no significant influence on Saudi kindergarten teacher's attitudes towards inclusive education. This finding is inconsistent with a Malaysian study in kindergarten settings that found a significant positive influence of having a family member, close relative, or friend with a disability on kindergarten teachers' attitudes towards inclusive education (Ramli, 2017)

However, in Saudi Arabia, as no previous studies have examined kindergarten teachers' attitudes towards inclusive education, the findings of the present study will be compared to a number of studies in primary and secondary settings (Al-Ahmadi, 2009; Alasim & Paul, 2019; Alquraini, 2011; Aseery, 2016). The findings of these studies were

consistent with the findings of current study and indicated that having family members or relatives with disabilities did not affect primary or secondary teachers' attitudes toward including students with specific disabilities in regular classrooms.

In the interview findings of this study, the factor of having a family member, close relative, or friend with a disability was not raised as a key factor influencing participants' attitudes towards inclusive education. Therefore, this factor appears to have no strong effect on Saudi kindergarten teachers' attitudes towards inclusive education.

Empathy for the families of children with disabilities and attitudes. The interview findings of this study showed that teachers' empathy for the families of children with disabilities is an important influence on kindergarten teachers' positive attitudes towards inclusive education. In the interview, a teacher ascribed her positive attitude towards inclusive education to her empathy for the families of children with disabilities and her understanding of their feelings and their urge to see their children learning in a regular kindergarten regardless of their disabilities. This result suggests that teachers' empathy has a positive effect on their attitude towards inclusive education.

Notably, there is limited research on the influence of teachers' empathy on attitudes towards inclusive education, nationally and internationally. Therefore, the current findings were compared with the study of Navarro-Mateu et al. (2019), which was conducted with teachers working at different educational levels, and found that teachers' empathy is positively related to their attitudes towards inclusive education. Combined with the findings of the current study, such results carve out a better perception of the effect of empathy on teachers' attitudes towards inclusive education.

Work-related enjoyment and attitudes. The interview findings of this study suggested that teachers' attitudes towards inclusive education could be influenced by how

much they enjoy their work. In the interview, a teacher revealed that her acceptance of inclusive education was due to her enjoyment of her work. She gets a chance to learn new concepts from children with disabilities, hence improving her knowledge base. She also claimed to get more fulfilment in caring and advocating for children with disabilities since this makes her life deeper and more meaningful.

It should be noted that there is a lack of research on the influence of work-related enjoyment on teachers' attitudes toward inclusive education. Previous research findings have mostly pointed at teachers' negative emotions towards inclusive education, and there is a lack of evidence that inclusive education can lead to positive emotions, such as satisfaction and enjoyment. However, the findings of this current study give a better insight into the positive effect of teachers' work-related enjoyment on their attitudes towards inclusive education.

9.2.3.2.2 Child-Related Factors

Types of disabilities and attitudes. In the current study, results of descriptive statistics (means and standard deviations) showed that the majority of kindergarten teachers held positive attitudes towards including children with speech and language disabilities, hearing disabilities, learning disabilities, physical disabilities, and visual disabilities in inclusive classrooms. They did, however, hold negative attitudes towards including children with behavioural disorders and autism, multiple disabilities, and intellectual disabilities.

The current study's findings can be compared to the few international studies that have examined kindergarten teachers' attitudes towards inclusive education in relation to types of disabilities. For example, Fakhri's (2019) findings are consistent with the findings of the current study, showing that most in-service kindergarten teachers in the United Arab Emirates held positive attitudes towards the inclusion of children with hearing and visual impairments and physical disabilities in regular classrooms, while they held negative attitudes towards including children with behavioural disorders. However, this study differed from the finding of the current study, which showed teachers held positive attitudes towards including children with intellectual disability and negative attitudes towards including children with learning disabilities and communication disorders. The current study's findings are also consistent with the findings of Lee et al. (2015), who found kindergarten teachers were more accepting of the inclusion of children with speech, language, and learning disabilities than of those with autism and behavioural disorders.

Specific to Saudi Arabia, most existing studies have focused on the attitudes of primary and high school teachers towards including students with a particular type of disability in regular classrooms (Alqahtani, 2017; Alquraini, 2011; Abed & Alrawajfah,

2017). The finding of the current study was broadly in line with such findings. For example, Alquraini (2011) reported that primary teachers were not accepting of including students with severe disabilities. Meanwhile, Alqahtani (2017) indicated that high school teachers had positive attitudes about including students with learning disabilities in regular classrooms. Another study by Abed and Alrawajfh (2017) explored primary school teachers' attitudes regarding the inclusion of students with different types of disabilities in regular classrooms; they found that teachers were more accepting of students with mild disabilities than of students with severe intellectual disabilities and behavioural disorders, based on their experience with these students in regular classrooms.

In the present study, the questionnaire findings were explored further through the interview findings. In the interviews, general and special education teachers with positive attitudes revealed that they held such attitudes because all children, regardless of their disabilities, exhibit some progress, whether academically or socially. They also mentioned that children without disabilities learned to respect and understand children with disability when they learn and play together. However, other general and special education teachers with less positive attitudes expressed that inclusive education for children with severe disabilities, such as severe behavioural disorders and intellectual disability, is not appropriate due to the harmful effects of their behaviour on other children and teachers, who do not know how to deal with them.

9.2.3.2.3 Context-related Factors

Class size and attitudes. The results of the multiple regression in the current study showed that class size was a significant negative predictor of the overall level of teacher self-efficacy on the ORI scale and on its three factors. This means that as the number of children in the classroom increases, teachers' attitudes towards inclusive education become more negative. When comparing the findings of the current study to the limited international studies about kindergarten teachers' attitudes in relation to class size, it must be pointed out that these studies have not examined the influence of class size as an independent factor on kindergarten teachers' attitudes towards inclusive education, but have revealed that large class size is an obstacle to effectively including children with disabilities in regular classrooms (Batu et al., 2017; Fasih, 2019). These studies found that although kindergarten teachers had positive attitudes towards inclusive education, they faced challenges to effective inclusion of children with disabilities in their regular classrooms due to large class sizes.

In Saudi Arabia, as already mentioned, no previous studies have examined kindergarten teachers' attitudes towards inclusive education. Therefore, the findings of the current study will be compared to limited studies that have examined the influence of class size on primary teachers' attitudes towards inclusive education, which were broadly in line with the current study's findings. For example, Alquraini (2012) showed that large class size has a significant influence on the negative attitudes of Saudi primary teachers towards the inclusion of students with severe intellectual disabilities. In addition, Alamri (2014) indicated that class size has a significant effect on primary teachers' attitudes; that is, the larger the class size, the less positive the teachers' attitudes were towards including students with AD/HD-related behaviours in regular classrooms.

In the current study, the significant influence of class size revealed in the questionnaire data can be explained by the interview findings, which drew attention to the importance of class size in influencing the practice of inclusion of children with disabilities in the kindergarten setting. In the interviews, as already mentioned, all teachers revealed that large class size was a barrier to effectively including children with disabilities in regular classrooms (see section 9.3 of this chapter for a further description of large class size as a barrier).

Number of special education teachers and attitudes. The findings of the multiple regression in the current study showed that the number of special education teachers in Saudi inclusive kindergartens had no significant influence on kindergarten teachers' attitudes towards inclusive education. It is worth noting that no international studies have investigated the influence of this factor on kindergarten teachers' attitudes towards inclusive education. Similarly, in Saudi Arabia, no studies have examined this association in primary or secondary settings.

The interview findings of the current study supported the questionnaire findings, in that none of the interview participants indicated the influence of the number of special education teachers on their attitudes towards inclusive education. Thus, it seems this factor did not affect Saudi kindergarten teachers' attitudes towards inclusive education.

9.3 Teachers' Perceptions of Barriers to Inclusive Education

In this section, the quantitative and qualitative findings presented both correspond research question 4.1: What are Saudi kindergarten teachers' perceptions of the barriers to the successful inclusion of children with disabilities in kindergarten settings?

The analysis of teachers' quantitative responses showed "the nature and severity of the child's disability" as the most significant barrier to effectively including children with disabilities in Saudi inclusive kindergarten settings. This was followed by "limited paraprofessionals to support children with a disability in the kindergarten" and "large class size." The teachers indicated that "negative religious and cultural beliefs towards the inclusion of children with disabilities in the inclusive kindergarten" was the least significant barrier (see Table 7.21 in Chapter 7). Teachers' perceived barriers to inclusive education were further explored in the qualitative phase of this study. The three significant barriers revealed through the analysis of questionnaire data were also revealed in the interview results, along with other important barriers. In the interviews, teachers identified very similar barriers regardless of whether they had a positive or less positive self-efficacy or attitudes. The following sections present the barriers that teachers identified in their interviews.

The nature and severity of the child's disability. The nature and severity of the child's disability was identified by teachers in the questionnaire (ranking) findings as the most significant barrier to successfully implementing inclusive education in Saudi kindergarten classrooms. In the interviews, the majority of teachers also identified the nature and severity of the child's disability as a barrier to successful inclusive education in kindergarten settings. These teachers revealed that they were better equipped to manage

some types of disabilities than others in the regular classroom. For instance, they noted that they were capable of addressing the learning needs of children with certain disabilities, such as physical, learning, and speech disabilities, whereas they found it difficult to meet the learning needs of children with other types of disabilities, such as intellectual disabilities, autism and behavioural disorders, and multiple disabilities. These teachers indicated that insufficient training and limited inclusion support services make it challenging to meet the learning needs and manage the behaviours of children with such disabilities in their inclusive settings and hinder the successful implementation of inclusive education. These findings echo previous studies that have indicated kindergarten teachers were more likely to express concerns about including children with severe intellectual disabilities, autism, and behavioural disorders due their limited knowledge and inadequate classroom support and resources (Avramidis & Norwich, 2002; Buysse et al., 1996; Huang & Diamond, 2009; Mohay & Reid, 2006).

It is notable that while the kindergarten teachers' self-efficacy and attitudes towards inclusion of children with specific types of disabilities varied, their self-efficacy and attitudes were generally positive towards inclusive education in general. The nature and severity of children's disabilities did not appear to adversely influence teachers' willingness to include children with severe intellectual disabilities, multiple disabilities, autism, and behavioural disorders. The teachers' perception of the nature and severity of the child's disability being a barrier to inclusion may, instead, reflect a high level of fear and concern on the part of the teachers pertaining to their limited knowledge and resources.

The absence of special aides. The absence of special aides in inclusive classrooms was identified by teachers in the questionnaire (ranking) findings as the second most significant barrier to successfully implementing inclusive education in Saudi kindergarten classrooms. This finding was corroborated during the teacher interviews, as all interviewed teachers noted that the lack of special aides in inclusive classrooms is a serious barrier and that they need the support of teacher aides to involve children with disabilities in the classroom and to address the individual needs of these children, especially in large classes. This finding is consistent with findings of previous international studies that have indicated a lack of special aides creates a significant barrier to successful inclusive education practices in kindergarten settings (Chiner & Cardona, 2013; Fakhri, 2019; Gezer & Aksoy, 2019). It is also consistent with several Saudi studies conducted in primary schools that revealed the lack of teacher aides served as an obstacle to accepting students with severe learning and intellectual disabilities in regular primary classrooms (Al-Ahmadi, 2009; Alquraini, 2011, 2012). These findings reflect that in Saudi Arabia kindergartens and schools lack teachers' aides who, according to the literature, can play an important role in supporting inclusive outcomes for children with disabilities. Aides can help to facilitate such outcomes by working under the classroom teacher's supervision to assist with one-on-one instruction, cooperative learning, and behaviour management (Ainscow et al., 2006; Bourke & Carrington, 2007). Therefore, recommendations for the Saudi Ministry of Education are provided later in this chapter pertaining to the need for special aides in inclusive kindergarten classrooms.

Large class size. As the questionnaire results also indicated, class size ranked in the interview responses as the third most significant barrier to effectively including children with disabilities in Saudi kindergarten inclusive settings, with all teachers interviewed agreeing that a large class size is an obstacle to including children with disabilities in the regular classroom. They indicated large classes containing 33 or more children, including children with different types of disabilities, are difficult to manage, and the large number of children in the class prevents teachers from effectively focusing on the individual needs of children. This was described as especially relevant when the class includes children with behavioural disorders who take teachers' time and focus away from other children, which affects the quality of the lessons. Interviewees also reported that including such a large number of children in a class impacts the ability of children with disabilities to pay attention and places increased pressure on the teacher, especially in the absence of teacher aides.

The current study's finding affirms previous studies that have demonstrated that crowded classrooms present a significant barrier to kindergarten teachers in trying to implement inclusive education in regular classrooms (Batu et al., 2017; Chiner & Cardona, 2013; Fasih, 2019; Gezer & Aksoy, 2019; Güleç-Aslan, 2020). Previous Saudi studies conducted in primary and secondary schools also demonstrate large classes are a significant impediment to the successful implementation of inclusive education (Alamri, 2014; Alhammad, 2017; Alquraini, 2011, 2012). Thus, a crowded classroom can be considered a significant barrier that negatively impacts the effective implementation of inclusive education in Saudi kindergarten and school settings. As such, appropriate recommendations for policymakers in the Saudi Ministry of Education are provided later in this chapter.

A lack of effective professional training. A lack of effective professional training was another barrier indicated by all teachers interviewed. Although six of the eight teachers interviewed had participated in training courses, sessions, and workshops (see Table 8.1 in Chapter 8), they noted that these training programs had failed to produce the desired outcomes. All teachers expressed a need for practical and well-designed professional training to increase their knowledge about inclusive education as well as to develop the skills they need both to manage the behaviours of children with disabilities and to incorporate appropriate instructional strategies to address their learning needs in the inclusive classroom. The teachers elaborated by providing examples of the types of training that need to be made available to both general and special education teachers; for instance, they expressed that practical training on sign language would be helpful for both general and special education teachers who have not previously specialised in teaching students with hearing disabilities to help them better meet the needs of these children when they are placed in the inclusive kindergarten. They also indicated a need for practical training on approaches to managing the challenging behaviours of children with disabilities in an inclusive setting. Some teachers commented on the Ministry of Education's overall failure to offer training courses to, in particular, general education teachers.

Previous studies have also identified that teachers' lack of practical training to manage inclusive classes was a barrier to effectively teaching children with disabilities in inclusive settings (Batu et al., 2017; Fakhri, 2019; Florian, 2009, 2011; Woodcock & Woolfson, 2019). The findings of the current study may reflect a general lack of preparedness of Saudi kindergarten teachers to teach children with disabilities in inclusive settings. This raises concerns about the roles of the Ministry of Education and universities in providing teachers with adequate pre- and in-service training to inform them about evidence-based inclusive practices and instructional strategies to apply to address the

diverse needs of children in inclusive kindergarten classrooms. Such training can be essential even for teachers who hold positive self-efficacy and attitudes towards inclusive education, because these teachers can also be frequently challenged by the demanding needs and behaviours of children with disabilities in the inclusive setting.

Discrepancies between the salaries of general and special education teachers.

Discrepancies between the salaries of general and special education teachers present another obvious barrier to implementing effective inclusive education, according to all the teachers interviewed. In Saudi Arabia, due to their specialisation in working with children with disabilities, special education teachers in public kindergartens and schools earn salaries up to 30% higher than the basic salaries earned by general education teachers. General education teachers expressed dissatisfaction about special education teachers earning higher salaries than they do. Special education teachers, in turn, asserted that these salary discrepancies discourage general education teachers from effectively including children with disabilities in their regular classrooms and from collaborating with special education teachers.

Most of these teachers endorsed increasing general education kindergarten teachers' salaries to incentivise them to work and collaborate effectively in inclusive classrooms. This finding broadly corroborates the findings of Alnahdi (2014) on one of the main barriers to including students with intellectual disabilities in regular primary classrooms, as general education teachers claim, special education teachers are paid 30% more than them, and therefore, they should be solely responsible for working with students with disabilities. These findings suggest that discrepancies between the salaries of general and special education teachers may facilitate unhealthy inclusive environments that negatively influence the quality of inclusive education in kindergarten settings by discouraging general

education teachers from collaboration with special education teachers and from working with children with disabilities in their regular classrooms.

In response to these findings, the current study will provide useful recommendations for the Ministry of Education and policymakers to take clear actions to ensure that all teachers take responsibility for educating children with disabilities in inclusive kindergarten settings and to ensure that general education teachers assist in making the kindergarten environment more supportive for children with disabilities.

A lack of collaboration between general and special education teachers. The majority of interviewed teachers identified the lack of collaboration between general and special education teachers as another major barrier to implementing inclusive education in Saudi kindergarten settings. Teachers in both groups declared that collaborative efforts between the two classifications of educators are limited and insufficient. This corroborates the findings of earlier literature that has identified a lack of collaboration between special and general education teachers as a major challenge to implementing effective inclusive education in regular classrooms (Bjørnsrud & Nilsen, 2019; Carter et al., 2009; Mitchell, 2014; Nilsen, 2020). In the current study, some general education teachers revealed that special education teachers do not collaborate with general education teachers on efforts to manage the inclusive classroom or to develop or adapt instructional methods and materials to address the learning needs of each child with disabilities in the inclusive classroom. Special education teachers, on the other hand, felt that general education teachers do not collaborate with them on developing individual educational plans for children with disabilities and do not participate in implementing those plans because they believe this is the responsibility of special education teachers.

Overall, these results indicate that collaboration between general and special education teachers is limited and arbitrary and varies from one kindergarten to another; furthermore, the findings convey that such collaboration is not considered an interactive process that engages both groups of teachers in working together to address the needs of children with disabilities and to implement effective inclusive education. This may reflect the teachers' lack of awareness about the Ministry of Education's organisational guide on tasks that require collaboration between special and general education teachers, especially on preparing individual educational plans for children with disabilities (Ministry of Education, 2016b). In light of these findings, this study makes recommendations pertaining to collaboration between general and special education teachers.

A lack of support from Principals. The majority of interviewed teachers identified the lack of support from Principals as a barrier to implementing successful inclusive education in kindergarten settings. They referred to their principals' lack of collaboration, as well as their lack of awareness of and knowledge about inclusive education, about the needs of children with disabilities, and about the role of general and special education teachers in inclusive settings. They asserted that, as a result, their Principals did not provide the necessary support or direction for implementing effective inclusive education. This is consistent with the findings of Smith and Smith (2000), Fasih (2019) and Sukbunpant et al. (2013) that indicated that a lack of support from the school's Principal prevents the promotion of effective and positive inclusive education practices in kindergarten settings. In addition, this finding supports other Saudi studies conducted in primary schools that have found that a lack of Principals' support challenges implementation of inclusive education in Saudi primary schools (Al-Ahmadi, 2009; Alhammad, 2017; Alquraini, 2011, 2012).

In light of these findings, it could be argued that the lack of Principals' support and awareness regarding inclusive education may lead these school Principals to make certain decisions that may negatively impact the effective implementation of inclusive practices or decrease teachers' enthusiasm for inclusive education. A body of literature has suggested that Principals play a key role in improving inclusive education practices and the outcomes of all learners, and without active, strong support from Principals, inclusive programs will not succeed (Hehir & Katzman, 2012; McLeskey & Waldron, 2015; Waldron et al., 2011). Recommendations that address this barrier to inclusive kindergarten education are provided later in this chapter.

Inappropriate physical environments. Inappropriate physical environments challenge the successful implementation of inclusive education in kindergarten settings, as indicated by the majority of interviewed teachers. These teachers revealed that their classrooms and kindergarten facilities do not support inclusive practices: according to their feedback, some of the kindergarten buildings are too old, have small doorways, have poor layouts and classroom spacing, or have no elevators or ramps. Therefore, children who require the assistance of a walker or a wheelchair would not be able to pass through easily. Moreover, the teachers claimed that although some kindergarten buildings are new and designed to serve as inclusive settings, they are not well-designed and do not provide a safe environment for children with behavioural and physical disabilities.

Supporting the present study's findings, prior international studies have demonstrated that inappropriate kindergarten physical environments impede the successful inclusion of children with disabilities, and modifications of the physical environment are needed so that children with disabilities can be engaged to the fullest extent possible in the educational and social programs of inclusive kindergartens (Chiner & Cardona, 2013; Fakhri,

2019; Gezer & Aksoy, 2019; Purdue, 2009). Furthermore, previous studies in the Saudi primary school context showed that the physical settings of most Saudi primary schools and classrooms were inappropriate due to lacking lifts and ramps, failing to ensure the safety of play and sports grounds, and unsuitable classroom design.

Thus, it can be argued that an inappropriate physical environment comprises a crucial barrier to implementing effective inclusive education in the Saudi context, which may limit the participation of children with disabilities in inclusive settings (Alhammad, 2017; Alquraini, 2011). Doctoroff (2001) pointed out that adapting the physical environment is fundamental in inclusive kindergarten settings to enable children with disabilities to participate fully in playing and learning, to meet the needs of all young children, and to convey the dominant message in terms of human values that all types of children can learn, have fun, and play together. As a result of the broader discussion in the literature and the findings of this study, useful recommendations emerge that can help to address the issue of the physical environment as it relates to supporting inclusive kindergarten programming.

9.4 Strengths of the Current Study

This study was the first study in Saudi Arabia to provide formal psychometric information in relation to the validity and reliability of Arabic versions of two previously well-established scales—the TEIP and the ORI—to measure teachers' self-efficacy and their attitudes towards inclusive education in kindergarten settings.

The present study was also the first in Saudi Arabia to provide insights into Saudi kindergarten teachers' self-efficacy and attitudes towards inclusive education for all children with different types of disabilities, the influence of teacher-related, child-related, and context-related factors on their self-efficacy and attitudes, and teachers' perceived

barriers to inclusive education in Saudi kindergarten settings. Moreover, this study adds to the limited international literature on teachers' self-efficacy and attitudes, the factors influencing their self-efficacy and attitudes, and the barriers to inclusive education in kindergarten settings.

The current study involved an adequate sample size, permitting more sophisticated analysis—such as confirmatory factor analysis, t-tests and multiple regression—to be conducted, helping provide more confidence in the findings. It will hopefully set a minimum standard for future research studies involving more rigorous comparative statistical analyses.

Another major strength of the present study is that it used a convergent mixed-methods approach to develop a rich and in-depth understanding of Saudi kindergarten teachers' self-efficacy, attitudes, and their perception of the barriers to inclusive education. As the mixed-methods design has not been a strong feature in inclusive education research internationally—or, more specifically, in Saudi Arabia—this study will make a significant contribution to the field.

This study also incorporated a range of teacher-, child-, and context-related factors that have not been incorporated into most international or Saudi Arabian studies, thus contributing to knowledge about kindergarten teachers' self-efficacy and attitudes towards inclusive education.

Finally, the present study contributes to the knowledge of inclusive education in Saudi kindergarten settings by enhancing understanding of the barriers that challenge the implementation of effective inclusive education. By adopting a mixed-methods approach, the qualitative aspect of the study was able to explore the challenging issues for inclusive education that were not covered in the quantitative element. As previously mentioned, in

the near future the Saudi Ministry of Education plans to improve inclusive education for all children with disabilities (Ministry of Education, 2019; Tatweer Co For Educational Services, n.d), making identifying potential barriers to the implementation of successful inclusive education in kindergarten settings necessary and timely.

9.5 Limitations of the Current Study

Along with the strengths identified in the previous section, three limitations need to be acknowledged. First, the study was conducted in a single specific setting (Riyadh, the capital city of Saudi Arabia) at a specific point in time. This may limit the generalisability of the results to teachers in other districts of Saudi Arabia.

Second, the study collected data only from teachers in public kindergartens; to enhance the potential for successful inclusive education for children with and without disabilities, additional information concerning kindergarten teachers' self-efficacy, attitudes, and perception of barriers in the private sector is needed.

Third, the current study relied on self-report data, which were collected through questionnaires and individual interviews. A combination of self-report and observational data in future research could identify the inclusionary behavioural outcomes of teachers' self-efficacy and attitudes towards inclusive education in Saudi kindergarten settings.

9.6 Implications for Future Research

This study raises several implications that could be considered in future studies. The two translated and adapted scales of TEIP and ORI are valid and reliable for measuring kindergarten teachers' self-efficacy and attitudes towards inclusive education. Thus, future studies in Saudi Arabia can utilise these scales in research with kindergarten inclusive education teachers.

The findings of the current study relied on a sample drawn from the capital city of Saudi Arabia (Riyadh) which was selected because it has currently the highest number of inclusive kindergartens. Therefore, replication of the current study in different cities across Saudi Arabia would help to validate the findings and add further insights into the results of this research.

Future research in Saudi Arabia may consider examining teachers' self-efficacy, attitudes, and perceptions of barriers to inclusive education in the private kindergarten sector. This could obtain additional information that would enhance the potential for successful inclusive education in Saudi kindergarten settings.

Future research could also be conducted in different countries to further investigate teachers' self-efficacy and their attitudes, the influence of teacher-related, child-related, and context-related factors on their self-efficacy and attitudes, and teachers' perceived barriers to inclusive education in kindergarten settings. The present study identified a limited number of studies on these topics in kindergarten settings. Therefore, it would be useful to obtain additional insights into these topics from different backgrounds, contexts, and cultures in inclusive kindergarten settings.

In addition, this study included an adequate sample size of general and special education teachers only. Future research, therefore, may consider examining kindergarten Principals' and parents' self-efficacy and attitudes towards inclusive education as well as the experiences of children with disabilities in inclusive kindergarten settings. This would support the development of policies and inclusive education practices in kindergarten settings, both nationally and internationally.

The adapted TEIP and ORI scales used in this study showed acceptable fit for the data after modifying and removing some items from both TEIP and ORI scales based on the CFA analysis. However, future replication of this study using the TEIP and ORI scales in Arabic contexts using the CFA analysis will help gain more understanding of the scales' psychometric properties.

9.7 Recommendations for the Ministry of Education

In the current study, special and general education teachers in Saudi kindergartens had generally positive self-efficacy and neutral attitudes towards inclusive education. The theory of planned behaviour suggests that the more positive self-efficacy (perceived behavioural control) and attitudes one has towards a particular behaviour, the greater one's intention is to perform that behaviour (Ajzen, 1991). This implies that teachers with high self-efficacy and positive attitudes towards the inclusion of children with disabilities will demonstrate more positive inclusionary behaviours, which will, in turn, facilitate more inclusive education for these children. The following recommendations for the Ministry of Education build on this strong foundation to develop and implement strategies to promote more positive self-efficacy and attitudes of teachers toward inclusive education. In addition, the current study was able to capture teachers' perceptions about broader barriers to inclusive education, which sit outside the teachers and relate to practice, policies, and funding. Bearing this in mind, the following recommendations are based on the major findings of this study, and are aimed at enhancing inclusive practices and developing an education system that provides the required support and resources for teachers to meet the needs of all children, with or without disabilities, in inclusive kindergarten settings; this will enhance future educational outcomes for Saudi Arabia.

The questionnaire findings indicated the substantial influence of class size on teachers' self-efficacy and attitudes towards inclusive education. Teachers also revealed in the interviews that large classes were a major barrier preventing them from effectively including and meeting the needs of children with disabilities in regular classes. Therefore, to enable teachers to offer individual attention and respond to the needs of all children, the Ministry of Education should consider ensuring that kindergarten teachers have smaller class sizes and that inclusive classrooms are not overcrowded when children with disabilities are included in regular classrooms.

The questionnaire findings of this study also indicated the substantial influence of Saudi kindergarten teachers' teaching position (general or special education teacher) on their self-efficacy and attitudes towards inclusive education. These findings indicated that special education teachers had higher self-efficacy and more positive attitudes than general education teachers. These findings suggest the Saudi Ministry of Education could consider advancing policies and regulations concerning the roles of kindergarten general and special education teachers in inclusive classroom. This could promote effective co-teaching and collaboration between groups of teachers, and thereby may generate more positive self-efficacy and attitudes towards implementing active and effective inclusive education programs in Saudi kindergarten settings.

The questionnaire and interview findings of this study indicated that Saudi kindergarten teachers' self-efficacy and attitudes towards inclusion of children with specific types of disabilities varied, and they perceived the nature and severity of the child's disability as a barrier to successful inclusive education in kindergarten settings. Although teachers' self-efficacy and attitudes were generally positive towards inclusive education in general, they expressed high levels of fear and concern about including children with

specific types of disabilities; these feelings pertained to insufficient inclusion support and a lack of effective training regarding the nature and severity of disabilities, modifying practices to meet the learning needs of all children with different types and severity of disabilities, and addressing their challenging behaviour properly in an inclusive classroom. Therefore, the Ministry of Education should provide inclusive kindergartens with all the necessary inclusive support services by disability type, and provide all teachers with appropriate and effective training programs about using a variety of inclusive instruction and teaching strategies to promote the learning and engagement of all children, with and without disabilities, in inclusive classrooms.

The interview findings of this study indicated that the need for special education teachers to teach outside their area of specialisation was a factor that influenced special education teachers with less positive self-efficacy in inclusive education. This has major implications for developing policy that aligns with inclusive education rather than special education, and the preparation of all teachers—special and general—in the direction of inclusive education and towards meeting the needs of all children with diverse abilities. Therefore, the Ministry of Education and the universities should consider applying inclusive education policies in both initial and continuing teacher education programs by shifting the focus of teacher education from special education to inclusive education. By doing so, the issues currently related to the need for special education teachers to teach outside their area of specialisation, as experienced in some Saudi kindergarten settings, can be successfully managed.

Although the questionnaire findings indicated that training about disabilities and in inclusive education has no statistically significant influence on teachers' self-efficacy and attitudes, the interview findings of this study indicated that a lack of effective professional

training was perceived as a barrier to the successful implementation of inclusive education in Saudi kindergarten settings. This finding suggests that the Ministry of Education should provide appropriate and effective pre- and in-service training programs for all kindergarten teachers. Such training courses should support evidence-based practice for the effective implementation of inclusive education, including managing inclusive classrooms, modifying the curriculum, collaborating effectively with other general and special education teachers, and using a variety of inclusive instructions and teaching strategies to address all children's needs and to manage the challenging behaviours of children with different types of disabilities and needs in inclusive classrooms. This could assist teachers to overcome any barriers to implementing successful inclusive education in Saudi kindergarten settings.

As illustrated by the questionnaire and interview findings of this study, teachers revealed that the absence of special aides was perceived as a barrier to the successful implementation of inclusive education in Saudi kindergarten settings. Accordingly, the Ministry of Education should employ special aides to support both special and general education could be accomplished by employing individuals with at least a high school diploma and by having them pass an examination to determine if they are eligible for the job.

The interview findings of the current study showed that the discrepancies between the salaries of general and special education teachers present an obvious barrier to implementing effective inclusive education. In Saudi Arabia, due to their specialisation in working with children with disabilities, special education teachers in public kindergartens and schools earn salaries up to 30% higher than the basic salaries earned by general education teachers. The Ministry of Education should, therefore, support equity between general and special education teachers to increase their perceptions of fairness. Such a

change may encourage kindergarten general education teachers to further support and address the needs of children with disabilities in the inclusive classroom, as required. In addition, this would generate a more positive self-efficacy and attitude towards inclusive education among general education teachers and would increase the number of children with disabilities in regular classrooms in Saudi kindergarten settings.

Moreover, the interview findings indicated that a lack of support from the Principal is perceived as a barrier to implementing effective inclusive education. The findings suggest that kindergarten principals need to be supportive, and fully aware of inclusive education and its implications and challenges. This would promote more positive teacher self-efficacy and attitudes, and help ensure the effective implementation of inclusive education in kindergarten settings. Therefore, the Ministry of Education needs to evaluate and guide principals' practice in inclusive kindergarten settings.

Finally, teachers in this study revealed that inappropriate physical environments were a barrier to successfully implementing inclusive education. The Ministry of Education, therefore, should provide inclusive support services to kindergartens so they can adapt the physical environment to assist children with disabilities. To fully participate in all activities with their typical peers, these children must be able to access regular classrooms and outdoor playgrounds. This involves the installation of elevators and ramps in kindergartens for those children who use wheelchairs, wide door frames for easy wheelchair passage, and the modification of classroom layouts and playgrounds to remove potential obstacles and hazards. Modifying the physical environment of inclusive kindergartens can facilitate the effective implementation of inclusive education and promote participation, access, and a sense of belonging in the daily learning experiences of children with disabilities, as well as improving teachers' self-efficacy and attitudes towards inclusive education.

9.8 Conclusion

This mixed-methods study was the first in Saudi Arabia to provide psychometric information on the adapted Teacher Efficacy for Inclusive Practices (TEIP) scale and the adapted Opinions Relative to the Integration of Students with Disabilities (ORI) scale in terms of measuring kindergarten teachers' self-efficacy and attitudes regarding inclusive education in Saudi kindergarten settings. This psychometric information was useful in strengthening the current study's findings and will support future research on teachers' self-efficacy and attitudes towards inclusive education in the kindergarten context. It was also the first to explore kindergarten teachers' self-efficacy and their attitudes towards inclusive education in Saudi kindergarten settings, the influence of teacher-related, child-related, and context-related factors on their self-efficacy and attitudes, and teachers' perceptions of barriers to successfully including children with disabilities in Saudi kindergarten settings.

The findings of confirmatory factor analysis and reliability analysis confirmed the validity and reliability of the two adapted scales (the TEIP and ORI scales) in the Saudi kindergarten context. The quantitative questionnaire data indicated that kindergarten teachers have generally somewhat positive self-efficacy and neutral attitudes towards inclusive education. The special education teachers, however, were found to exhibit higher self-efficacy and attitudes across the TEIP and ORI scales and the related factors than the general education teachers, although the latter did still exhibit positive self-efficacy and attitudes. A significant strong positive relationship was identified between teachers' self-efficacy and their attitudes towards inclusive education.

The findings emerging from both the quantitative and qualitative analysis demonstrated the influence of teacher-, child-, and context-related factors on teachers' self-efficacy and attitudes towards inclusive education. The multiple regression analysis

indicated that teacher-related factors (i.e., age, teaching position) and a context-related factor (i.e., class size) had a statistically significant influence on both teachers' self-efficacy and teachers' attitudes, while one teacher-related factor (i.e., experience in an inclusive education setting) had a statistically significant influence solely on teachers' attitudes concerning inclusive education. With regard to the assessment of child-related factor, the ranking and descriptive analysis indicated that the teachers tended to exhibit higher positive self-efficacy and attitudes concerning the inclusion of children with speech and language disorders, hearing disabilities, learning disabilities, physical disabilities, and visual disabilities. However, the teachers tended to exhibit lower self-efficacy and attitudes concerning the inclusion of children with behavioural disorders, autism, intellectual disabilities, and multiple disabilities.

The qualitative interview findings revealed the stories behind teachers' level of self-efficacy and their attitudes towards inclusive education by providing a deeper understanding of the factors influencing kindergarten teachers with more positive or less positive self-efficacy and attitudes. The factors found to foster higher positive self-efficacy on the part of teachers included encouragement from the Principal, teachers' passion and enthusiasm, collaboration with special education teachers, and the achievements of children with disabilities. However, the factors found to foster lower positive self-efficacy among teachers included a lack of knowledge and experience, a lack of collaboration between teachers, and the need to teach outside their area of specialisation. In terms of attitudes, the factors found to foster more positive attitudes towards inclusive education included witnessing children's progress and growth, having empathy for the families of children with disabilities, and work-related enjoyment; the factors found to foster less positive attitudes included the detrimental effects of inclusion on children with and without disabilities and the type and severity of the children's disabilities.

The quantitative and qualitative findings indicated that kindergarten teachers perceived several barriers to the successful delivery of inclusive education in their kindergartens. These barriers included the nature and severity of the child's disability, the absence of special aides in inclusive classrooms, large class size, lack of effective professional training, lack of collaboration between general and special education teachers, discrepancies between the salaries of general and special education teachers, and inappropriate physical environments within kindergartens.

From these findings, several implications were derived to guide future research and help advance knowledge in this emerging field of study. Furthermore, the current findings privileged the voices of teachers in inclusive kindergartens to shape recommendations that could assist educational officials in making the necessary changes in policy, resourcing, and practice in order to successfully implement effective inclusivity in kindergarten settings. Such shifts in policy and practice could indeed help Saudi Arabia realise its 2030 vision for ensuring fair, quality, and inclusive education for all.

References

- Abed, M. G., & Alrawajfh, S. (2017). Elementary school teachers' attitude towards including students with special educational needs into regular public schools in Saudi Arabia. *International Journal of Education*, 9(1), 49–66.
<https://doi.org/10.5296/ije.v9i1.10915>
- Abduljawad, N. M., Alkhatib, M. S., Alsenbl, A. A., & Metwally, M. (2008). *Kingdom of Saudi Arabia: Education system*. Al-kheraiji.
- Adhabi, E. (2018). *The perceptions of elementary school special education and general education teachers on full inclusion of students with autism spectrum disorder (ASD) in Saudi Arabia* [Doctoral dissertation]. Saint Louis University.
- Ainscow, M., Booth, T., & Dyson, A. (2006). *Improving schools, Developing inclusion*. Routledge.
- Ajzen, I. (1991). The theory of planned behaviour. *Organizational Behaviour and Human Decision Processes*, 50(2), 179–211. [http://dx.doi.org/10.1016/0749-5978\(91\)90020-I](http://dx.doi.org/10.1016/0749-5978(91)90020-I)
- Ajzen, I. (2005). *Attitudes, personality and behaviour* (2nd ed.). Open University Press.
- Al-Ahmadi, N.A. (2009). Teachers' perspectives and attitudes towards integrating students with learning disabilities in regular Saudi public schools. [Doctoral dissertation]. Ohio University, Athens, United States.
- Alamri, S. S. (2014). *Students with AD/HD-related behaviours: Saudi mainstream teachers' knowledge and attitudes towards inclusion* [Doctoral thesis]. Queensland University of Technology, Queensland, Australia.

- Alasim, K., & Paul, P. V. (2019). Understanding factors that affect teachers' attitudes toward inclusion of students who are hard of hearing in Saudi Arabia. *Deafness & Education International*, 21(4), 210–226. <https://doi.org/10.1080/14643154.2018.1489950>
- Alhammad, M. (2017). *The issues of implementing inclusion for students with Learning Difficulties in mainstream primary schools in Saudi Arabia* [Doctoral dissertation]. University of Lincoln.
- Alhudaithi, G. S. (2015). *Saudi Arabian female teachers' attitudes towards the inclusion of children with autism into mainstream classrooms* [Doctoral thesis]. <http://etheses.whiterose.ac.uk/12373/>
- Al-Jadidi, N. (2012). *The professional preparation, knowledge and beliefs of kindergarten teachers in Saudi Arabia* (Order No. U590160). Available from ProQuest Dissertations & Theses Global. (1414975289). Retrieved from <http://search.proquest.com.mutex.gmu.edu/docview/1414975289?accountid=14541>
- Al Jaffal, M. (2019). *The attitudes of secondary school teachers regarding inclusion of students with autism in Saudi Arabia* [Doctoral dissertation, Duquesne University]. Retrieved from <https://dsc.duq.edu/etd/1755>
- Al-Mousa, N. A. (1999). *Development process of special education in Saudi Arabia*. Riyadh, Saudi Arabia: Directorate General of Special Education in Saudi Arabia.
- Al-Mousa, N. A. (2010). *The experience of the Kingdom of Saudi Arabia in mainstreaming students with special educational needs in public schools (a success story)*. Retrieved from <http://unesdoc.unesco.org/images/0019/001916/191663e.pdf>

- Al-Mousa, N. A., Al-Saratawi, Z. A., Al-Abduljabbar, A. M., Al-Batal, Z. M., & AlHusain, A. S. (2008). *The national study to evaluate the experience of the Kingdom of Saudi Arabia in mainstreaming students with special educational needs in public schools*. Ministry of Education.
- Alnahdi, G. H. (2014). Special education programs for students with intellectual disability in Saudi Arabia: Issues and recommendations. *Journal of the International Association of Special Education*, 15(1), 83–91.
- Alnahdi, G. H. (2019a). Are we ready for inclusion? Teachers' perceived self-efficacy for inclusive education in Saudi Arabia. *International Journal of Disability, Development and Education*, 67(2), 182–193.
- Alnahdi, G. H. (2019b). The positive impact of including students with intellectual disabilities in schools: Children's attitudes towards peers with disabilities in Saudi Arabia. *Research in Developmental Disabilities*, 85, 1–7
- Alnahdi, G. H. (2019c). The Arabic version of the Teacher Efficacy for Inclusive Practices (TEIP-AR) scale: A construct validity study. *Cogent Education*, 6(1), 1-11.
<https://doi.org/10.1080/2331186X.2019.1618516>
- Alqahtani, M. (2017). *Teacher perspectives on full inclusion of students with learning disabilities in Saudi Arabia high schools* [Doctoral dissertation]. Indiana State University.
- Alquraini, T. A. (2012). Factors related to teachers' attitudes towards the inclusive education of students with severe intellectual disabilities in Riyadh, Saudi. *Journal of Research in Special Educational Needs*, 12(3), 170-182. <https://doi.org/10.1111/j.1471-3802.2012.01248.x>

- Alquraini, T. A. (2011). Teachers' Perspectives of Inclusion of the Students with Severe Disabilities in Elementary Schools in Saudi Arabia. [Doctoral Thesis]. Ohio University, Athens, United States.
- Alquraini, T. A. S., & Rao, S. M. (2018). A study examining the extent of including competencies of inclusive education in the preparation of special education teachers in Saudi universities. *International Journal of Disability, Development, & Education*, 65(1), 108-122. <https://doi.org/10.1080/1034912X.2017.1327651>
- Antonak, R., & Larrivee, B. (1995). Psychometric analysis and revision of the opinions relative to mainstreaming scale. *Exceptional Children*, 62(2), 139–149. Retrieved from <http://journals.cec.sped.org/>
- Aseery, F. (2016). Teachers' attitudes toward the inclusion of deaf and hard of hearing students in regular education classrooms in Saudi Arabia.[Doctoral dissertation].Muncie, United States
- Avramidis, E., & Norwich, B. (2002). Teachers' attitudes towards integration/inclusion: A review of the literature. *European Journal of Special Needs Education*, 17(2), 129-147.
- Awang, Z. (2012). *Structural equation modeling using AMOS graphic*. Penerbit Universiti Teknologi MARA,Shah Alam.
- Bandura, A. (1997). Self-efficacy: The exercise of control. Freeman.
- Bandura, A. (1986). *Social foundations of thought and action: A social cognitive theory*. Prentice Hall.

- Batu, E., Odluyurt, S., Alagözoglu, E., Çattık, M., & Şahin, S. (2017). Determining the opinions of preschool teachers regarding inclusion. *Ozel Egitim Dergisi*, 18(3), 401–420.
- Bentler, P. M. (1990). Comparative fit indexes in structural models. *Psychological Bulletin*, 107(2), 238–246. <https://doi.org/doi:10.1037/0033-2909.107.2.238>
- Bergman, M. M. (2008). The strawmen of the qualitative quantitative divide. In M. M. Bergman (Ed.), *Advances in Mixed Methods Research: Theories and applications*. (pp.11-21). SAGE Publications.
- Bjørnsrud, H., & Nilsen, S. (2019). Joint reflection on action—A prerequisite for inclusive education? A qualitative study in one local primary/lower secondary school in Norway. *International Journal of Inclusive Education*, 23(2), 158–173. <https://doi.org/10.1080/13603116.2018.1427153>
- Bhatnagar, N., & Das, A. (2014). Attitudes of secondary school teachers towards inclusive education in New Delhi, India. *Journal of Research in Special Educational Needs*, 14(4), 255-263
- Blackburn, C. (2016). Early childhood inclusion in the United Kingdom. *Infants & Young Children*, 29(3), 239–246.
- Bourke, P. E., & Carrington, S. (2007). Inclusive education reform: Implications for teacher aides. *Australasian Journal of Special Education*, 31(1), 15–24.
- Braun, V., & Clarke, V. (2006). Using thematic analysis in psychology. *Qualitative Research in Psychology*, 3(2), 77–101. <https://doi.org/10.1191/1478088706qp063oa>
- Braun, V., & Clarke, V. (2013). *Successful qualitative research: A practical guide for*

beginners. Sage.

Bronfenbrenner, U. (2009). *The ecology of human development: Experiments by nature and design*. Harvard University Press.

Brown, S. E., & Guralnick, M. J. (2012). International human rights to early intervention for infants and young children with disabilities. *Infants & Young Children, 25*(4), 270–285. <https://doi.org/10.1097/IYC.0b013e318268fa49>

Brown, T. A. (2015). *Confirmatory factor analysis for applied research* (2nd ed.). Guilford Press.

Browne, M. W., & Cudeck, R. (1993). Alternative ways of assessing model fit. In K. A. Bollen & J. S. Long (Eds.), *Testing structural equation models* (pp. 136–162). Sage.

Brownell, M. T., & Pajares, F. (1999). Teacher efficacy and perceived success in mainstreaming students with learning and behavior problems. *Teacher Education and Special Education, 22*, 154–164. <https://doi.org/10.1177/088840649902200303>

Bryant, J. P. (2018). A phenomenological study of preschool teachers' experiences and perspectives on inclusion practices. *Cogent Education, 5*(1), 1-12. <https://doi.org/10.1080/2331186X.2018.1549005>

Bunch, G. & Valeo, A. (2004). Student attitudes toward peers with disabilities in inclusive and special education schools. *Disability & Society, 19*(1), 61–76. <https://doi.org/10.1080/0968759032000155640>

Burić, I., & Moè, A. (2020). What makes teachers enthusiastic: The interplay of positive affect, self-efficacy and job satisfaction. *Teaching and Teacher Education, 89*, 103008. <https://doi.org/10.1016/j.tate.2019.103008>

- Buysse, V., Wesley, P. W., Keyes, L., & Bailey, D. B. (1996). Assessing the comfort zone of childcare teachers in serving young children with disabilities. *Journal of Early Intervention, 20*, 189-203. <https://doi.org/10.1177/105381519602000301>.
- Byrne, B. (2016). *Structural equation modeling with AMOS: Basic concepts, applications, and programming* (3rd ed.). Routledge.
- Carter, N., Prater, M. A., Jackson, A., & Marchant, M. (2009). Educators' perceptions of collaborative planning processes for students with disabilities. *Preventing School Failure: Alternative Education for Children and Youth, 54*, 60-70
- Chan, D. W. (2008). Dimensions of teacher self-efficacy among Chinese secondary school teachers in Hong Kong. *Educational Psychology, 28*(2), 181–194.
- Chiner, E. & Cardona, M. C. (2013). Inclusive education in Spain: How do skills, resources, and supports affect regular education teachers' perceptions of inclusion? *International Journal of Inclusive Education, 17*(5), 526–541.
- Cohen, J. (1988). *Statistical power analysis for the behavioral sciences* (2nd ed.). Lawrence Erlbaum Associates.
- Cohen, L., Manion, L., & Morrison, K. (2013). *Research methods in education*. Routledge.
- Council of Ministries. (2020). *Basic law of governance*. Retrieved from <https://laws.boe.gov.sa/BoeLaws/Laws/LawDetails/16b97fcb-4833-4f66-8531-a9a700f161b6/2>
- Creswell, J. W. (2014). *A concise introduction to mixed methods research*. Sage Publications.

- Creswell, J. W. (2015). *Educational research: Planning, conducting, and evaluating quantitative and qualitative research* (5th ed.). Pearson.
- Creswell, J.W., & Plano Clark, V. L. (2018). *Designing and conducting mixed methods research*. Sage Publications.
- Daniels, V. (2018). A comparative study of k12 general education and special education teachers' self-efficacy levels towards inclusion of students with special needs. [Doctoral dissertation]. Northcentral University School of Education.
- De Boer, A., S. J. Pijl, S. J., & Minnaert, A. (2011). Regular primary schoolteachers' attitudes towards inclusive education: A review of the literature. *International Journal of Inclusive Education*, 15(3), 331–353. <https://doi.org/10.1080/13603110903030089>
- Deiner, P. L. (2013). *Inclusive early childhood education: Development, resources, practice*. Wadsworth Cengage Learning.
- DeVellis, R. F. (2012). *Scale development: Theory and applications* (3rd ed.). Sage.
- Dias, P. C., & Cadime, I. (2016). Effects of personal and professional factors on teachers' attitudes towards inclusion in preschool. *European Journal of Special Needs Education*, 31(1), 111–123.
- Division for Early Childhood/National Association for the Education of Young Children. (2009). *Early childhood inclusion: A joint position statement of the Division for Early Childhood (DEC) and the National Association for the Education of Young Children (NAEYC)*. The University of North Carolina, FPG Child Development Institute.
- Retrieved from https://www.naeyc.org/files/naeyc/file/positions/DEC_NAEYC_EC_updatedKS.pdf

- Doctoroff, S. (2001). Adapting the physical environment to meet the needs of ‘all’ young children for play. *Early Childhood Education Journal*, 29(2), 105–109.
<https://doi.org/10.1023/A:1012524929004>.
- Duffy, M. E. (2006). Translating instruments into other languages: Basic considerations. *Clinical Nurse Specialist*, 20(5), 225–226.
- Duschesne, S., & McMaugh, A. (2019). *Educational psychology: For learning and teaching* (6th ed.). Cengage.
- Du Plessis, A. E. (2019). Barriers to effective management of diversity in classroom contexts: The out-of-field teaching phenomenon. *International Journal of Educational Research*, 93, 136–152.
- Dymond, S. K., Renzaglia, A. & Chun, E. J. (2008). Inclusive high school service learning programs: Methods for and barriers to including students with disabilities. *Education and Training in Developmental Disabilities*, 43(1), 20-36.
- ECA/ECIA. (2012). *Position statement on the inclusion of children with disability in early childhood education and care*. Retrieved from <http://www.ecia.org.au/documents/item/31>
- Edmonds, W. A., & Kennedy, T. D. (2016). *An applied guide to research designs: Quantitative, qualitative, and mixed methods*. Sage Publications.
- Emam, M. M., & Mohamed, A. H. H. (2011). Preschool and primary school teachers’ attitudes towards inclusive education in Egypt: The role of experience and self-efficacy. *Procedia-Social and Behavioural Sciences*, 29, 976–985.

- Eremenco, S.L., Cella, D., & Arnold, B. J. (2005). A comprehensive method for the translation and cross-cultural validation of health status questionnaires. *Evaluation Health Professionals, 28*(2), 212–232.
- Ewing, D., Monsen, J., & Kielblock, S. (2018). Teachers' attitudes towards inclusive education: A critical review of published questionnaires. *Educational Psychology in Practice, 34*(2), 150–165.
- Fakih, M. (2019). *Teachers' attitudes towards inclusion of learners with disabilities at American private early childhood education in Dubai: An investigative study* [Master's dissertation]. The British University in Dubai (BUiD).
- Field, A. (2017). *Discovering statistics using IBM SPSS statistics* (5th ed.). SAGE Publications Ltd.
- Fishbein, M., & Ajzen, I. (2010). *Predicting and changing behaviour: The reasoned action approach*. Psychology Press (Taylor & Francis).
- Flick, U. (2018). *Doing triangulation and mixed methods*. Sage Publications.
- Florian, L. (2009). Preparing teachers to work in “schools for all.” *Teaching and Teacher Education, 25*(4), 533–534. <http://dx.doi.org/10.1016/j.tate.2009.02.004>
- Florian, L. (2011). Introduction—Mapping international developments in teacher education for inclusion. *Prospects, 41*(3), 319–321. <https://doi.org/10.1007/s11125-011-9202-x>
- Foreman, P. (2000). *Integration and inclusion in action* (2nd ed.). Harcourt Brace & Company.

- Forlin, C., Cedillo, I., Romero-Contreras, S., Fletcher, T., & Hernandez, H. (2010). Inclusion in Mexico: Ensuring supportive attitudes by newly graduated teachers. *International Journal of Inclusive Education*, 14(7), 723-739. <https://doi.org/10.1080/13603111003778569>
- Francisco, C. D. C. (2019). School principals' transformational leadership styles and their effects on teachers' self-efficacy. *International Journal of Advanced Research*, 7(10), 622–635. <https://doi.org/10.21474/IJAR01/9875>
- Francois, J. (2020). The relationship between pre-service training and teaching self-efficacy for inclusive practices. *Educational Considerations*, 45(3), 8. <https://doi.org/10.4148/0146-9282.2182>
- Fyssa, A., Vlachou, A., & Avramidis, E. (2014). Early childhood teachers' understanding of inclusive education and associated practices: Reflections from Greece. *International Journal of Early Years Education*, 22(2), 223–237.
- Galaterou, J., & Antoniou, A. S. (2017). Teachers' attitudes towards inclusive education: The role of job stressors and demographic parameters. *International Journal of Special Education*, 32(4), 643–658.
- Gay, L. R., Mills, G. E., & Airasian, P. (2012). *Educational research: Competencies for analysis and applications* (9th ed.). Pearson.
- General Authority for Statistics. (2017). *Population estimates*. Retrieved from <https://www.stats.gov.sa/en/43>

- Gezer, M., S., & Aksoy, V. (2019). Perceptions of Turkish preschool teachers about their roles within the context of inclusive education. *International Journal of Early Childhood Special Education*, 11(1), 31–42. <https://doi.org/10.20489/intjecse.583541>
- Giddings, L. S. (2006). Mixed-methods research, positivism dressed in drag? *Journal of Research in Nursing*, 11(3), 195–203. <https://doi.org/10.1177/1744987106064635>
- Goodfellow, J. (1988). Early intervention in New South Wales: A mosaic of policy and practice. In M. Pieterse, S. Bochner, & S. Bettison (Eds.), *Early intervention for children with disabilities: The Australian experience* (pp. 7–20). Special Education Centre, Macquarie University.
- Graham, L.J. (2020). *Inclusive education for the 21st century: theory, policy and practice*. Allen& Unwin.
- Greene, J. C. (2007). *Mixed methods in social inquiry*. Jossey-Bass.
- Guba, E. G., & Lincoln, Y. S. (1989). *Fourth generation evaluation*. Newbury Park.
- Güleç-Aslan, Y. (2020). Experiences of Turkish preschool teachers for including children with autism spectrum disorders: Challenges faced and methods used. *International Journal of Psychology and Educational Studies*, 7(2), 37-49
- Guo, Y., Justice, L. M., Sawyer, B., & Tompkins, V. (2011). Exploring factors related to preschool teachers' self-efficacy. *Teaching and Teacher Education*, 27, 961-968
- Guskey, T. R., & Passaro, P. D. (1994). Teacher efficacy: A study of construct dimensions. *American Educational Research Journal*, 31(3), 627–643.

- Hair, J. F., Babin, B. J., Anderson, R. E., & Black, W. B. (2018). *Multivariate data analysis: A global perspective* (8th ed.). Cengage Learning EMEA.
- Hair, J. F., Black, W. B., Babin, B. J., & Anderson, R. E. (2010). *Multivariate data analysis: A global perspective* (7th ed.). Pearson Education, Inc.
- Haimour, A. I., & Obaidat, Y. F. (2013). School teachers' attitude toward inclusion of students with autism in Saudi Arabia. *International Journal of Current Research*, 5(10), 2970- 2977.
- Hakim, A. (2012). *The educational system and its policy*. Etrak Publishing.
- Harrington, D. (2009). *Confirmatory factor analysis*. Oxford University Press.
- Hehir, T., & Katzman, L. (2012). *Effective inclusive schools: Designing successful schoolwide programs*. Jossey-Bass.
- Heyvaert, M., Maes, B., & Onghena, P. (2013). Mixed methods research synthesis: Definition, framework, and potential. *Quality & Quantity*, 47(2), 659–676.
<https://doi.org/10.1007/s11135-011-9538-6>
- Hofman, R. H., & Kilimo, J. S. (2014). Teachers' attitudes and self-efficacy towards inclusion of pupils with disabilities in Tanzanian schools. *Journal of Education and Training*, 1(2), 177–198.
- Hosford, S., & O'Sullivan, S. (2016). A climate for self-efficacy: The relationship between school climate and teacher efficacy for inclusion. *International Journal of Inclusive Education*, 20(6), 604–621.

- Hoyle, R. H. (1995). Writing about structural equation models. In R. H. Hoyle & A. T. Panter (Eds.), *Structural equation modeling: Concepts, issues, and applications* (pp. 158–176). Sage.
- Hsieh, W. H., & Hsieh, C. M. (2012). Urban early childhood teachers' attitudes towards inclusive education. *Early Child Development and Care, 182*(9), 1167–1184.
- Hsieh, W. Y., Hsieh, C. M., Ostrosky, M. M., & McCollum, J. A. (2012). Taiwanese first grade teachers' perceptions of inclusive education. *The International Journal of Inclusive Education, 16*(1), 71–88.
- Huang, H.-H., & Diamond, K. E. (2009). Early childhood teachers' ideas about including children with disabilities in programmes designed for typically developing children. *International Journal of Disability Development and Education, 56*(2), 169-182.
<https://doi.org/10.1080/10349120902868632>
- Hussain, A. S. (2017). UAE preschool teachers' attitudes toward inclusion education by specialty and cultural identity [Doctoral dissertation]. Walden University, Washington, US.
- Jamsai, P. (2018). Thai secondary teachers' attitudes toward inclusion of students with learning disabilities into general education classrooms [Doctoral dissertation]. University of Northern Colorado, Greeley, US.
- Jason L, & Glenwick, D. (2016). *Handbook of methodological approaches to community-based research: Qualitative, quantitative, and mixed methods*. Oxford University Press.

- Johnson, R. B., & Onwuegbuzie, A. J. (2004). Mixed methods research: A research paradigm whose time has come. *Educational Researcher*, 33(7), 14–26.
<https://doi.org/10.3102/0013189X033007014>
- Kavale, K. A. (2002). Mainstreaming to full inclusion: From orthogenesis to the pathogenesis of an idea. *International Journal of Disability, Development, and Education*, 49(2), 201–214.
- Kemp, C. R. (2016). Early childhood inclusion in Australia. *Infants & Young Children*, 29(3), 178–187.
- Khashrami, S. (2010). Inclusion of children with special needs in kindergarten in Saudi Arabia. *Journal of Educational Science*, 34, 2.
- Kim, H. (2017). Early childhood preservice teachers' passion, beliefs, and their sense of teacher efficacy. *Journal of Education and Human Development*, 6(1), 44-52.
<https://doi.org/10.15640/jehd.v6n1a4>
- Kline, R. (1998). *Principles and practice of structural equation modelling*. The Guilford Press.
- Kline, R. (2013). *Exploratory and confirmatory factor analysis*. In Y. Petscher & C. Schatschneider (Eds.), *Applied quantitative analysis in the social sciences* (pp. 171-207). Routledge.
- Kline, R. (2016). *Principles and practice of structural equation modeling* (4th ed.). Guilford Press.

- Koch, T. (1994). Establishing rigour in qualitative research: The decision trail. *Journal of Advanced Nursing*, 19(5), 976–986. <https://doi.org/10.1111/j.1365-2648.1994.tb01177.x>
- Larrivee, B., & Cook, L. (1979). Mainstreaming: A study of variables affecting teacher attitudes, *Journal of Special Education*, 13, 315-324.
- Leatherman, J. M. (2007). “I just see all children as children”: Teachers’ perceptions about inclusion. *The Qualitative Report*, 12(4), 594–611.
- Lee, F., L., M., Tracey, D. Barker, K., Fan, J., C., M., & Yeung, A., S. (2014). What predicts teachers’ acceptance of students with special educational needs in kindergarten? *Australian Journal of Educational & Developmental Psychology*, 14, 60–70.
- Leedy, P. D., & Ormrod, J. E. (2012). *Practical research: Planning and design*. Pearson Education, Inc.
- Lee Rodgers, J., & Nicewander, W. (1988). Thirteen ways to look at the correlation coefficient. *The American Statistician*, 42(1), 59–66.
- Levene, H. (1960). Robust tests for the equality of variances. In I. Olkin (Ed.), *Contributions to probability and statistics* (pp. 278–292). Palo Alto, CA: Stanford University Press.
- Little, C., (2017). Social inclusion and autism spectrum disorder. In C. Little (Ed.), *Supporting social inclusion for students with autism spectrum disorder* (pp. 9–20). Routledge. <https://doi.org/doi:10.4324/9781315641348>
- Little, C. (2020). Collaboration and consultation. In Spandagou, I., Little, C., Evans, D., Bonati, M.L. (2020). *Inclusive education in schools and early childhood settings*. NY, New York: Springer.

- Liu, W., & Gumah, B. (2020). Leadership style and self-efficacy: The influences of feedback. *Journal of Psychology in Africa, 30*(4), 289–294.
<https://doi.org/10.1080/14330237.2020.1777033>
- Loreman, T., U. Sharma, and C. Forlin. 2013. “Do pre-Service Teachers Feel Ready to Teach in Inclusive Classroom? A Four Country Study of Teaching Self-Efficacy.” *Australian Journal of Teacher Education, 38* (1): 27–44. <https://doi.org/10.14221/ajte.2013v38n1.10>.
- MacCallum, R. C., Browne, M. W., & Sugawara, H. M. (1996). Power analysis and determination of sample size for covariance structure modeling. *Psychological Methods, 1*(2), 130–149. <https://doi.org/10.1037/1082-989x.1.2.130>.
- Mahat, M. (2008). The development of a psychometrically-sound instrument to measure teachers’ multidimensional attitudes toward inclusive education. *International Journal of Special Education, 23*(1), 82–92.
- Maiorca-Nunez, J. (2017). *Teacher attitudes & beliefs toward inclusion of students with disabilities in early childhood programs: Impacts on assessment outcomes*. [Doctoral dissertation]. California State University, Fullerton, US.
- Malinen, O.-P., Savolainen, H, & Xu, J. (2012). Beijing in-service teachers’ self-efficacy and attitudes towards inclusive education. *Teaching and Teacher Education, 28*(4), 526–534. <https://doi.org/10.1016/j.tate.2011.12.004>
- Maxwell, J. A. (2013). *Qualitative research design: An interactive approach* (3rd ed.). Sage.
- McLeskey, J., & Waldron, N. (2015). Effective leadership makes schools truly inclusive. *Phi Delta Kappan, 96*(5), 68-73.

- Mehdinezhad, V., & Mansouri, M. (2016). School principals' leadership behaviours and its relation with teachers' sense of self-efficacy. *International Journal of Instruction*, 9(2), 51–60. <https://doi.org/10.12973/iji.2016.924a>
- Meijer, C. W., & Watkins, A. (2019). Financing special needs and inclusive education—from Salamanca to the present. *International Journal of Inclusive Education*, 23(7–8), 705–721. <https://doi.org/10.1080/13603116.2019.1623330>
- Mertens, D. M. (2014). *Research and evaluation in education and psychology: Integrating diversity with quantitative, qualitative, and mixed methods* (4th ed.). Sage.
- Michell, J. (2003). The quantitative imperative: Positivism, naive realism and the place of qualitative methods in psychology. *Theory & Psychology*, 13(1), 5–31. <https://doi.org/10.1177/0959354303013001758>
- Michell, J. (2011). Qualitative research meets the ghost of Pythagoras. *Theory & Psychology*, 21(2), 241–259. <https://doi.org/10.1177/0959354310391351>
- Ministry of Education. (1976). *Educational policy: Government Decree 89/A/23/03/76*.
Ministry of Education.
- Ministry of Education. (2015). *Directorate General of Special Education*. Retrieved from <http://www.moe.gov.sa/ar/Ministry/BoysEducationAgency/SpecialEducation/Pages/AboutTheDepartment.aspx>
- Ministry of Education. (2016a). *Summary statistics on general education in S.A. for the academic year 2014/2015*. Retrieved from <http://www.moe.gov.sa/ar/Pages/StatisticalInformation.aspx>
- Ministry of Education. (2016b). *Organisational guide for special education*. Retrieved from

<https://departments.moe.gov.sa/SPED/Documents/RegulatoryGuide.pdf>

Ministry of Education. (2018a). *Organisational guide for early childhood education*.

Retrieved from

<https://departments.moe.gov.sa/EducationAgency/RelatedDepartments/Kindergarten/Documents/Organizational%20Guide%202nd%201439.pdf>

Ministry of Education. (2018b). *Organisational guide for special education*. Retrieved from

https://edu.moe.gov.sa/Taif/Sections/EducationalAffairs/Pages/Special_Edu.aspx

Ministry of Education. (2019a). *Development of early childhood education*. Retrieved from

<https://www.moe.gov.sa/ar/PublicEducation/Pages/Kindergarten.aspx>

Ministry of Education. (2019b). *Summary statistics on general education in S.A. for the academic year 2017/2018*. Retrieved from

<https://www.moe.gov.sa/ar/Pages/StatisticalInformation.aspx>

Ministry of Education. (2019c). *Education levels*. Retrieved from

<http://www.mohe.gov.sa/en/studyinside/aboutKSA/Pages/Education.aspx>

Ministry of Education. (2019d). *Organisational guide for kindergarten education*. Retrieved

from <https://www.moe.gov.sa/ar/PublicEducation/Pages/Kindergarten.aspx>

Mitchell, D. (2014). *What really works in special and inclusive education: Using evidence-based teaching strategies*. Routledge.

Mohay, H. A., & Reid, E. N. (2006). The inclusion of children with a disability in childcare:

the influence of experience, training and attitudes of childcare staff. *Australian*

Journal of Early Childhood, 31(1), 35-42.

- Navarro-Mateu, D., Franco-Ochoa, J., Valero-Moreno, S., & Prado-Gascó, V. (2019). To be or not to be an inclusive teacher: Are empathy and social dominance relevant factors to positive attitudes towards inclusive education? *PLoS ONE*, *14*(12).
<https://doi.org/10.1371/journal.pone.0225993>
- Nilsen, S. (2018) Inside but still on the outside: Teachers' experiences with the inclusion of children with special educational needs in general education, *International Journal of Inclusive Education*. <https://doi.org/10.1080/13603116.2018.1503348>
- Odom, S. L., Buysse, V., & Soukakou, E. (2011). Inclusion for young children with disabilities: A quarter century of research perspectives. *Journal of Early Intervention*, *33*(4), 344–356.
- Odom, S. L., Peck, C. A., Hanson, M., Beckman, P. J., Lieber, J., Brown, W. H., Schwartz, I. S. (1996). Inclusion at the preschool level: An ecological systems analysis. *Social Policy Report: Society for Research in Child Development*, *10*(2–3), 18–30.
- Odom, S. L., Vitztum, J., Wolery, R., Lieber, J., Sandall, S., Hanson, M. J., Horn, E. (2004). Preschool inclusion in the United States: A review of research from an ecological systems perspective. *Journal of Research in Special Educational Needs*, *4*(1), 17–49.
- Özokcu, O. (2018a). Investigating preschool teachers' self-efficacy in inclusion practices in Turkey. *International Education Studies*, *11*(9), 79–89.
- Özokcu, O. (2018b). The relationship between teacher attitude and self-efficacy for inclusive practices in Turkey. *Journal of Education and Training Studies*, *6*(3), 6–12.
- Pallant, J. (2013). *SPSS survival manual: A step by step guide to data analysis using SPSS* (5th ed.). Allen & Unwin.

- Parasuram, K. (2006). Variables that affect teachers' attitudes towards disability and inclusive education in mumbai, India. *Disability and Society*, 21(3), 231–242.
<https://doi.org/10.1080/09687590600617352>
- Park, M., Dimitrov, D. M., Das, A., & Gichuru, M. (2016). The teacher efficacy for inclusive practices (TEIP) scale: Dimensionality and factor structure. *Journal of Research in Special Educational Needs*, 16(1), 2-12.
- Purdue, K. (2009). Barriers to and facilitators of inclusion for children with disabilities in early childhood education. *Contemporary Issues in Early Childhood*, 10(2), 133-143
- Peters, S. J. (2004). *Inclusive education: An EFA strategy for all children*. Retrieved from <http://www.eldis.org/vfile/upload/1/document/0708/DOC16941.pdf>
- Pituch, K. A., & Stevens, J. P. (2016). *Applied multivariate statistics for social sciences* (6th ed.). New York: Routledge.
- Rahayu, W. F., & Kurniawati, F. (2019, December). The influence of teacher self-efficacy in teaching towards teacher attitude in inclusive preschool. In *3rd International Conference on Special Education (ICSE 2019)*. Atlantis Press.
- Rakap, S., Cig, O., & Parlak-Rakap, A. (2017). Preparing preschool teacher candidates for inclusion: Impact of two special education courses on their perspectives. *Journal of Research in Special Educational Needs*, 17(2), 98–109.
- Ramli, L. I. B. (2017). *Attitudes of preschool teachers towards the introduction of inclusive education (IE) in Malaysian government preschools* [Doctoral dissertation]. University of Leeds. UK

- Roach, V. (1995). Supporting inclusion: Beyond the rhetoric. *Phi Delta Kappan*, 77(4), 295–99.
- Robson, C., & Kieran, M. (2016). *Real world research: A resource for users of social research methods in applied settings* (4th ed.). Wiley-Blackwell.
- Royal Embassy of Saudi Arabia, Washington, DC. (2019). *About Saudi Arabia: Fact & figures*. Retrieved from <https://www.saudiembassy.net/about-saudi-arabia>
- Russell, P. (1984). The Education Act 1981: Implications for pre-school services. *Early Child Development and Care*, 15(4), 361–366. <https://doi.org/10.1080/0300443840150407>
- Salanova, M., Llorens, S., & Schaufeli, W. B. (2011). Yes, I can, I feel good & I just do it! On gain cycles and spirals of efficacy beliefs, affect, and engagement. *Applied Psychology: An International Review*, 60(2), 255–285. <https://doi.org/10.1111/j.1464-0597.2010.00435.x>
- Sari, H., Celikoz, N., & Seçer, Z. (2009). An analysis of pre-school teachers' and student teachers' attitudes to inclusion and their self-efficacy. *International Journal of Special Education*, 24(3), 29–44.
- Savolainen, H., Engelbrecht, P., Nel, M., & Malinen, O.-P. (2012). Understanding teachers' attitudes and self-efficacy in inclusive education: Implication for pre-service and in-service teacher education. *European Journal of Special Needs Education*, 27(1), 51–68. <https://doi.org/10.1080/08856257.2011.613603>
- Savolainen, H., Malinen, O. P., & Schwab, S. (2020). Teacher efficacy predicts teachers' attitudes towards inclusion—A longitudinal cross-lagged analysis. *International*

Journal of Inclusive Education, 1–15.

<https://doi.org/10.1080/13603116.2020.1752826>

Sharma, U., Armstrong, A. C., Merumeru, L., Simi, J., & Yared, H. (2019). Addressing barriers to implementing inclusive education in the Pacific. *International Journal of Inclusive Education*, 23(1), 65–78. <https://doi.org/10.1080/13603116.2018.1514751>

Sharma, U., Loreman, T., & Forlin, C. (2012). Measuring teacher efficacy to implement inclusive practices. *Journal of Research in Special Educational Needs*, 12(1): 12–21. <https://doi.org/10.1111/j.1471-3802.2011.01200.x>

Sheskin, D. (2007). *Handbook of parametric and nonparametric statistical procedures* (4th ed.). Taylor & Francis.

Siegel, S., & Castellan, N. J. (1988). *Nonparametric statistics for the behavioral sciences* (2nd ed.). McGraw-Hill.

Skrtic, T. (1991). The special education paradox: Equity as the way to excellence. *Harvard Educational Review*, 61(2), 148-207.

Slee, R. (2018). *Defining the scope of inclusive education*. Paper commissioned for the 2020 Global Education Monitoring Report, Inclusion and Education.

Smith, M. K., & Smith, K. E. (2000). “I believe in inclusion, but...”: Regular education early childhood teachers’ perceptions of successful inclusion. *Journal of Research in Childhood Education*, 14(2), 161–180. <https://doi.org/10.1080/02568540009594761>

Soodak, L. C., Podell, D. M., & Lehman, R. (1998). Teacher, student, and school attributes as predictors of teachers’ responses to inclusion. *The Journal of Special Education*, 31(4), 480-490

- Štemberger, T., & Kiswarday, V. (2018). Attitude towards inclusive education: The perspective of Slovenian preschool and primary school teachers. *European Journal of Special Needs Education, 33*(1), 47–58.
<https://doi.org/10.1080/08856257.2017.1297573>
- Sucuoğlu, B., Bakkaloğlu, H., Karasu, F. İ., Demir, Ş., & Akalın, S. (2013). Inclusive preschool teachers: Their attitudes and knowledge about inclusion. *International Journal of Early Childhood Special Education, 5*(2), 107–128.
- Sukbunpant, S., Arthur-Kelly, M., & Dempsey, I. (2013). Thai preschool teachers' views about inclusive education for young children with disability. *International Journal of Inclusive Education, 17*(10), 1106–1118.
<https://doi.org/10.1080/13603116.2012.741146>
- Tabachnick, B. G., & Fidell, L. S. (2013). *Using multivariate statistics* (6th ed.). Pearson.
- Tatweer Co for Educational Services. (n.d). *Integrated solutions for special education*. Retrieved from
<https://t4edu.com/ar/services/view/MjRlMUFIQXZ4cklZWElzazRVc05WZz09>
- Teddlie, C., & Tashakkori, A. (2010). Overview of contemporary issues in mixed methods research. In C. Teddlie & A. Tashakkori (Eds.), *Sage handbook of mixed methods in social & behavioral research* (2nd ed., pp. 1–42). Sage.
- Thomazet, S. (2009). From integration to inclusive education: Does changing the terms improve practice? *International Journal of Inclusive Education, 13*(6), 553–563.
<https://doi.org/10.1080/13603110801923476>
- Tobin, G. A., & Begley, C. M. (2004). Methodological rigour within a qualitative framework.

Journal of Advanced Nursing, 48(4), 388–396. <https://doi.org/10.1111/j.1365-2648.2004.03207.x>

Tschannen-Moran, M., Woolfolk Hoy, A., & Hoy, W. (1998). Teacher efficacy: Its meaning and measure. *Review of Educational Research*, 68(2), 202-248.

Tschannen-Moran, M., & Woolfolk Hoy, A. (2001). Teacher efficacy: Capturing an elusive construct. *Teaching and Teacher Education*, 17(7), 783–805.

UNESCO. (1994). *The Salamanca Statement and framework for action on special needs education*. Retrieved from http://www.unesco.org/education/pdf/SALAMA_E.PDF

UNESCO. (2005). *Guidelines for inclusion: Ensuring access to education for all*. UNESCO.

UNESCO. (2009). *Policy guidelines on inclusion in education*. UNESCO.

UNESCO, International Bureau of Education. (2008). *Conclusions and recommendations of the 48th session of the International Conference on Education (ED/BIE/CONFINTED 48/5)*. UNESCO, International Bureau of Education.

UNESCO, International Bureau of Education. (2009). Inclusive education: The way of the future. In *Final report from the International Conference on Education*. Geneva: UNESCO, International Bureau of Education.

United Nations. (2006). *United Nations Convention on the Rights of Persons with Disabilities*. United Nations.

United Nations Development Programme. (2020). *Sustainable development goals*. Retrieved from <https://www.undp.org/content/undp/en/home/sustainable-development-goals/goal-4-quality-education.html>

University of Oregon. (n.d.). *Building more inclusive education in Saudi Arabia*. Retrieved from <https://education.uoregon.edu/news/building-more-inclusive-saudi-arabia>

Vision 2030. (n.d.-a). *Vision realization programs*. Retrieved from <https://vision2030.gov.sa/en/programs>

Vision 2030. (n.d.-b). *The human capital development program*. Retrieved from <https://vision2030.gov.sa/en/programs/HCDP>

Warnock, M. (1979). Children with special needs: The Warnock Report. *British Medical Journal*, 1, 667–668.

Waldron, N., McLeskey, J., & Redd, L. (2011). Setting the direction: The role of the principal in developing an effective, inclusive school. *Journal of Special Education Leadership*, 24(2), 51–60.

Wang, Mian, Zan, Fei, Liu, Jiaqiu, Liu, Chunling, & Sharma, Umesh. (2012). A Survey Study of Chinese In-service Teachers' Self-efficacy About Inclusive Education. *The Journal of International Special Needs Education*, 15(2), 107-119.

Weisel, A., & Dror, O. (2006). School climate, sense of efficacy and Israeli teachers' attitudes toward inclusion of students with special needs. *Education, Citizenship and Social Justice*, 1(2), 157-74. <https://doi.org/10.1177/1746197906064677>

Winzer, M. A. (2009). *From integration to inclusion: A history of special education in the 20th century*. Gallaudet University Press.

Wong, S. & Cumming, T. (2010). Family day care is for normal kids: Facilitators and barriers to the inclusion of children with disabilities in family day care. *Australasian Journal of Early Childhood*, 35(3), 4-12.

- Woodcock, S. (2021). Teachers' beliefs in inclusive education and the attributional responses toward students with and without specific learning difficulties. *Dyslexia*, 27(1), 110–125.
- Woodcock, S., & Faith, E. (2021). Am I to blame? Teacher self-efficacy and attributional beliefs towards students with specific learning disabilities. *Teacher Development*, 1–24. <https://doi.org/10.1080/13664530.2020.1863256>
- Woodcock, S., & Jones, G. (2020). Examining the interrelationship between teachers' self-efficacy and their beliefs towards inclusive education for all. *Teacher Development*, 24(4), 583–602. <https://doi-org.ezproxy.uws.edu.au/10.1080/13664530.2020.1803957>
- Woodcock, S., & Woolfson, L. M. (2019). Are leaders leading the way with inclusion? Teachers' perceptions of systemic support and barriers towards inclusion. *International Journal of Educational Research*, 93, 232–242. <https://doi.org/10.1016/j.ijer.2018.11.004>
- Wynn, T. M. (2018). General education teachers' self-efficacy to teach autistic students in kindergarten through fourth grade general education classrooms. [Doctoral dissertation]. Gardner-Webb University, Boiling Springs, Us.
- Yada, A., & Savolainen, H. (2017). Japanese in-service teachers' attitudes toward inclusive education and self-efficacy for inclusive practices. *Teaching and Teacher Education*, 64, 222–229.
- Yada, A., Tolvanen, A., & Savolainen, H. (2018). Teachers' attitudes and self-efficacy on implementing inclusive education in Japan and Finland: A comparative study using

multi-group structural equation modelling. *Teaching and Teacher Education*, 75, 343–355. <https://doi.org/10.1016/j.tate.2018.07.011>

Yada, A., & Savolainen, H. (2019). Japanese and Finnish Teachers' Perceptions and Self-Efficacy in Inclusive Education. *Journal of Research in Special Educational Needs*, 19, 60-72. <https://doi.org/10.1111/1471-3802.12478>

You, S., Kim, E. K., & Shin, K. (2019). Teachers' belief and efficacy toward inclusive education in early childhood settings in Korea. *Sustainability*, 11(5), 14-89.

Zhang, Y., & Wildemuth, B. M. (2009). Qualitative analysis of content. In B. Wildemuth (Ed.), *Applications of social research methods to questions in information and library science* (pp. 308–319).

Zhu, J., Li, H., & Hsieh, W. Y. (2019). Implementing inclusive education in an early childhood setting: A case study of a Hong Kong kindergarten. *Early Child Development and Care*, 189(2), 207–219.
<https://doi.org/10.1080/03004430.2017.1307841>

APPENDICES

APPENDIX A

Section 1: Teacher's Demographic Information:

Directions: Please tick (✓) your response to each item.

1. How old are you?

_____ years.

2. What is your highest level of education that you have completed (please tick one)?

- Diploma
- Bachelor
- Master
- Doctoral

3. Teaching focus:

3.1 You currently work as:

- General Education Teachers
- Special Education Teachers

3.2. What is your area of specialisation (please select all that apply to you)?

- Behavioural Disorders and Autism
- Intellectual Disabilities
- Hearing Disabilities
- Learning Disabilities
- Speech and Language Disorders
- Visual Disabilities

4- Teaching experiences:

4.1 How many years have you been teaching in General Education?

Please, specify _____ years.

4.2 How many years have you been teaching in Special Education?
Please, specify _____years.

4.3 How many years have you been teaching in Inclusive Education?
Please, specify _____years.

5- How many children are in your current classroom?

Please, specify _____children

6- Not counting yourself, please specify the number of special education teachers in your school:

7- Do you have special aides in your classroom?

- Yes
- No

8- Since being a qualified teacher, have you attended any training about children with disabilities or in inclusive education

- Yes
- No

9- Do you have any family member or close relative or friend with disabilities?

- Yes
- No

Section 2: Teachers' Confidence Toward Including Children with Disabilities in The Inclusive Kindergarten Classroom.

2.1 This survey is designed to investigate teachers' confidence in their ability to work with children with disabilities and without disabilities in inclusive kindergarten classrooms.

-Please indicate how much you agree or disagree with the following statements

No	Statement	Strongly Disagree	Disagree	Neither agree nor disagree	Agree	Strongly Agree
1	I can make my expectations clear about children's behaviour.	<input type="radio"/>	<input type="radio"/>	<input type="radio"/>	<input type="radio"/>	<input type="radio"/>
2	I am able to calm a child who is disruptive or noisy.	<input type="radio"/>	<input type="radio"/>	<input type="radio"/>	<input type="radio"/>	<input type="radio"/>
3	I can make parents feel comfortable coming to school.	<input type="radio"/>	<input type="radio"/>	<input type="radio"/>	<input type="radio"/>	<input type="radio"/>
4	I can assist families in helping their children do well in school.	<input type="radio"/>	<input type="radio"/>	<input type="radio"/>	<input type="radio"/>	<input type="radio"/>
5	I can accurately gauge the children's comprehension of what I have taught.	<input type="radio"/>	<input type="radio"/>	<input type="radio"/>	<input type="radio"/>	<input type="radio"/>
6	I can provide appropriate challenges for very capable children.	<input type="radio"/>	<input type="radio"/>	<input type="radio"/>	<input type="radio"/>	<input type="radio"/>
7	I am confident in my ability to prevent disruptive behaviour in the classroom before it occurs.	<input type="radio"/>	<input type="radio"/>	<input type="radio"/>	<input type="radio"/>	<input type="radio"/>
8	I can control disruptive behaviour in the classroom	<input type="radio"/>	<input type="radio"/>	<input type="radio"/>	<input type="radio"/>	<input type="radio"/>
9	I am confident in my ability to get parents involved in school activities of their children with disabilities.	<input type="radio"/>	<input type="radio"/>	<input type="radio"/>	<input type="radio"/>	<input type="radio"/>
10	I am confident in designing learning tasks so that the individual needs of children with disabilities are accommodated	<input type="radio"/>	<input type="radio"/>	<input type="radio"/>	<input type="radio"/>	<input type="radio"/>
11	I am able to get children to follow classroom rules.	<input type="radio"/>	<input type="radio"/>	<input type="radio"/>	<input type="radio"/>	<input type="radio"/>
12	I can collaborate with other professionals (e.g., itinerant teachers or speech pathologists) in designing educational plans for children with disabilities	<input type="radio"/>	<input type="radio"/>	<input type="radio"/>	<input type="radio"/>	<input type="radio"/>
13	I am able to work jointly with other professionals and staff (e.g., aides, other teachers) to teach children with disabilities in the classroom.	<input type="radio"/>	<input type="radio"/>	<input type="radio"/>	<input type="radio"/>	<input type="radio"/>
14	I can use a variety of assessment strategies (for-example, performance-based assessment, child observations, portfolios etc.).	<input type="radio"/>	<input type="radio"/>	<input type="radio"/>	<input type="radio"/>	<input type="radio"/>
15	I am confident in my ability to get children to work together in pairs or in small groups.	<input type="radio"/>	<input type="radio"/>	<input type="radio"/>	<input type="radio"/>	<input type="radio"/>
16	I am confident in informing others who know little about laws and policies relating to the inclusion of children with disabilities.	<input type="radio"/>	<input type="radio"/>	<input type="radio"/>	<input type="radio"/>	<input type="radio"/>

17	I am confident when dealing with children who are physically aggressive.	<input type="radio"/>	<input type="radio"/>	<input type="radio"/>	<input type="radio"/>	<input type="radio"/>
18	I am able to provide an alternate explanation or an example when children with disabilities are confused.	<input type="radio"/>	<input type="radio"/>	<input type="radio"/>	<input type="radio"/>	<input type="radio"/>

2.3. How confident would you feel with including children with disabilities in your classroom? From the list of disabilities below, please rank order where (1) represents your highest level of confidence and (8) represents your least level of confidence with including children with these specific disabilities in your classroom.

I am most confident including children with:

Type of Disabilities	Rank order
Behavioural Disorders and Autism	
Intellectual Disabilities	
Hearing Disabilities	
Learning Disabilities	
Speech and Language Disorders	
Visual Disabilities	
Physical Disabilities	
Multiple Disabilities	

Section 3: Kindergarten Teachers' Attitudes Toward Inclusive Education.

3.1 This survey aims to investigate teachers' attitudes toward including children with and without disabilities in the one classroom.

-Please indicate how much you agree or disagree with the following statements

No	Statement	Strongly Disagree	Disagree	Neither agree nor disagree	Agree	Strongly Agree
1	Most children with disabilities will make an adequate attempt to complete their learning tasks.	<input type="radio"/>	<input type="radio"/>	<input type="radio"/>	<input type="radio"/>	<input type="radio"/>
2	Inclusion of children with disabilities will necessitate extensive retraining of General classroom teachers.	<input type="radio"/>	<input type="radio"/>	<input type="radio"/>	<input type="radio"/>	<input type="radio"/>
3	Inclusion offers mixed group interaction that will foster understanding and acceptance of differences among children.	<input type="radio"/>	<input type="radio"/>	<input type="radio"/>	<input type="radio"/>	<input type="radio"/>
4	It is likely that the child with disability will exhibit behaviour problems in an inclusive classroom.	<input type="radio"/>	<input type="radio"/>	<input type="radio"/>	<input type="radio"/>	<input type="radio"/>
5	Children with disabilities can best be served in inclusive classrooms.	<input type="radio"/>	<input type="radio"/>	<input type="radio"/>	<input type="radio"/>	<input type="radio"/>
6	The extra attention children with disabilities require will be to the detriment of the other children.	<input type="radio"/>	<input type="radio"/>	<input type="radio"/>	<input type="radio"/>	<input type="radio"/>
7	The challenge of being in an inclusive classroom is promoting the academic growth of the child with a disability.	<input type="radio"/>	<input type="radio"/>	<input type="radio"/>	<input type="radio"/>	<input type="radio"/>
8	Inclusion of children with disabilities will require significant changes in inclusive classroom procedures.	<input type="radio"/>	<input type="radio"/>	<input type="radio"/>	<input type="radio"/>	<input type="radio"/>
9	Increased freedom in the general classroom creates too much confusion for the child with a disability.	<input type="radio"/>	<input type="radio"/>	<input type="radio"/>	<input type="radio"/>	<input type="radio"/>
10	General classroom teachers have the abilities necessary to work with children with disabilities.	<input type="radio"/>	<input type="radio"/>	<input type="radio"/>	<input type="radio"/>	<input type="radio"/>
11	The presence of children with disabilities will not promote acceptance of differences on the part of children without disabilities.	<input type="radio"/>	<input type="radio"/>	<input type="radio"/>	<input type="radio"/>	<input type="radio"/>
12	The behaviour of children with disabilities will set a bad example for students without disabilities.	<input type="radio"/>	<input type="radio"/>	<input type="radio"/>	<input type="radio"/>	<input type="radio"/>
13	The child with a disability will probably develop academic skills more rapidly in an inclusive classroom than in a special classroom.	<input type="radio"/>	<input type="radio"/>	<input type="radio"/>	<input type="radio"/>	<input type="radio"/>
14	Inclusion of the child with a disability will not promote his or her social.	<input type="radio"/>	<input type="radio"/>	<input type="radio"/>	<input type="radio"/>	<input type="radio"/>

15	It is not more difficult to maintain order in an inclusive classroom that contains a child with a disability than in one that does not contain a child with a disability.	<input type="radio"/>	<input type="radio"/>	<input type="radio"/>	<input type="radio"/>	<input type="radio"/>
16	children with disabilities will not monopolize the general classroom teacher's time.	<input type="radio"/>	<input type="radio"/>	<input type="radio"/>	<input type="radio"/>	<input type="radio"/>
17	The inclusion of children with disabilities can be beneficial for children without disabilities.	<input type="radio"/>	<input type="radio"/>	<input type="radio"/>	<input type="radio"/>	<input type="radio"/>
18	Children with disabilities are likely to create confusion in the inclusive classroom.	<input type="radio"/>	<input type="radio"/>	<input type="radio"/>	<input type="radio"/>	<input type="radio"/>
19	General-classroom teachers have sufficient training to teach children with disabilities.	<input type="radio"/>	<input type="radio"/>	<input type="radio"/>	<input type="radio"/>	<input type="radio"/>
20	Inclusion will likely have a negative effect on the emotional development of the child with a disability.	<input type="radio"/>	<input type="radio"/>	<input type="radio"/>	<input type="radio"/>	<input type="radio"/>
21	Children with disabilities should be given every opportunity to function in the inclusive classroom when possible.	<input type="radio"/>	<input type="radio"/>	<input type="radio"/>	<input type="radio"/>	<input type="radio"/>
22	The classroom behaviour of the child with a disability does not generally require more patience from the teacher than does the classroom behaviour of the child without a disability.	<input type="radio"/>	<input type="radio"/>	<input type="radio"/>	<input type="radio"/>	<input type="radio"/>
23	Teaching children with disabilities is better done by special education teachers instead of general classroom teachers.	<input type="radio"/>	<input type="radio"/>	<input type="radio"/>	<input type="radio"/>	<input type="radio"/>
24	Special classrooms can have beneficial effects on the social and emotional development of the child with a disability.	<input type="radio"/>	<input type="radio"/>	<input type="radio"/>	<input type="radio"/>	<input type="radio"/>
25	The child with a disability will not be socially isolated in the inclusive classroom.	<input type="radio"/>	<input type="radio"/>	<input type="radio"/>	<input type="radio"/>	<input type="radio"/>

3.2 To what extent do you agree that children with these specific disabilities should be included in an inclusive classroom?

No	Statement	Strongly Disagree	Disagree	Neither agree nor disagree	Agree	Strongly Agree
1	Children with Behavioural Disorders and Autism.	<input type="radio"/>	<input type="radio"/>	<input type="radio"/>	<input type="radio"/>	<input type="radio"/>
2	Children with Intellectual Disabilities	<input type="radio"/>	<input type="radio"/>	<input type="radio"/>	<input type="radio"/>	<input type="radio"/>
3	Children with Hearing Disabilities	<input type="radio"/>	<input type="radio"/>	<input type="radio"/>	<input type="radio"/>	<input type="radio"/>
4	Children with Learning Disabilities	<input type="radio"/>	<input type="radio"/>	<input type="radio"/>	<input type="radio"/>	<input type="radio"/>
5	Children with Speech and Language Disabilities.	<input type="radio"/>	<input type="radio"/>	<input type="radio"/>	<input type="radio"/>	<input type="radio"/>
6	Children with Visual Disabilities	<input type="radio"/>	<input type="radio"/>	<input type="radio"/>	<input type="radio"/>	<input type="radio"/>
7	Children with Physical Disabilities	<input type="radio"/>	<input type="radio"/>	<input type="radio"/>	<input type="radio"/>	<input type="radio"/>
8	Children with Multiple Disabilities	<input type="radio"/>	<input type="radio"/>	<input type="radio"/>	<input type="radio"/>	<input type="radio"/>

Section 4: Teachers' perceptions of the barriers to inclusive education in kindergarten settings.

4.1. In your opinion, rank order from 1 through to 13, what you consider to be the most significant (1) to least significant (13) barrier to the inclusion of children with disabilities in inclusive classroom.

The most significant barriers limiting the inclusion of children with disabilities in inclusive classroom are:

Barriers	Rank Order
Lack of teachers' confidence to support children with disabilities in their classroom.	
The nature and severity of the child's disability means they are unable to be included in the inclusive kindergarten.	
Negative teachers' attitudes toward inclusion of children with disabilities.	
Lack of laws and policies related to the inclusion of children with disabilities.	
Lack of teachers' knowledge and skills in including children with disabilities.	
Inappropriate physical environment for children with disabilities.	
Lack of curriculum and materials to support the learning and teaching of children with disabilities.	
Poor involvement and support from families of children with disabilities.	
Limited paraprofessionals to support children with a disability in the kindergarten.	
Lack of teachers' time.	
Large class size in which the child with disability attends.	
Lack of the kindergarten Principal and the educational supervisor's support for the inclusion of children with disabilities.	
Negative religious and cultural beliefs towards the inclusion of children with disabilities in the inclusive kindergarten.	

Would you be willing to meet with me at your convenience to participate in a brief audio-recorded interview to discuss your responses to the questionnaire? (please circle)

Yes

No

If YES, could you please provide me with your name, telephone number or email address so that I can contact you to arrange an interview?

Name:

Phone:

Email:

APPENDIX B

Arabic Version of the Questionnaires



أختي المعلمة الفاضلة وفقها الله

السلام عليكم ورحمة الله وبركاته وبعد،

أن هذه الدراسة البحثية أقوم بها استكمالاً لمتطلبات الحصول على درجة الدكتوراه بكلية التربية من جامعة غرب سيدني في أستراليا.

تهدف هذه الدراسة إلى الكشف عن كفاءات واتجاهات معلمات رياض الأطفال نحو دمج الأطفال ذوي الإعاقة مع الأطفال العاديين في رياض الأطفال. حيث ستساهم هذه الدراسة -بإذن الله- في تطوير خطط تطويرية فعالة لتحسين برامج الدمج في رياض الأطفال.

لكونك أحد أفراد العينة المستهدفة في هذه الدراسة ولرايتك أهمية كبرى في تحقيق أهداف الدراسة، لذا لعل منك التكرم بتعبئة هذه الاستبانة، علماً بأن جميع المعلومات التي سيتم جمعها من خلال الاستبانة ستُعامل بسرية تامة ولن تستخدم إلا لغرض البحث العلمي فقط.

تعليمات مهمة قبل تعبئة الاستبانة:

١/ يرجى قراءة أسئلة الاستبانة بعناية والاجابة عليها عن طريق اختيار الإجابة المناسبة بدقة وموضوعية لأن تلك سيساعد الباحثة على الوصول إلى النتائج التي تأمل تحقيقها. إذا لم تكوني متأكدة من إجابتك فيرجى اختيار الإجابة الأقرب من وجهة نظرك.

٢/ مدة تعبئة الاستبانة لن تستغرق من وقتك للثمن أكثر من (٢٠ دقيقة).

٣/ هذه الاستبانة تتكون من **أربعة أقسام:**

القسم الأول: يتناول بعض المعلومات الأساسية الخاصة بك.

القسم الثاني: يتناول أسئلة تتعلق بمدى تفكك في قدراتك لتدريس الأطفال ذوي الإعاقة مع الأطفال العاديين في صف دراسي واحد.

القسم الثالث: يتناول أسئلة تتعلق بتوجهاتك نحو دمج الأطفال ذوي الإعاقة.

القسم الرابع: يتناول أسئلة تتعلق بالعوامل المعيقة لعملية دمج الأطفال ذوي الإعاقة.

إذا كان لديك أي استفسار أو أسئلة حول هذه الدراسة، لا تتردد في التواصل مع الباحثة عن طريق البريد الإلكتروني التالي:

s.alzhrani@westernsydney.edu.au

شاكراً ومقدرة حسن تعاونك وتجاوبك.

القسم الأول:

أولاً: معلومات عامة:

١- كم عمرك؟

فضلاً حددي

٢- ماهو أعلى مؤهل علمي حصلت عليه؟

دبلوم قبل الجامعة

بكالوريوس

ماجستير

دكتوراه



٣- ماهي وظيفتك الحالية؟

- معلمة رياض أطفال بالتعليم العام.
- معلمة تربية خاصة

٣.٢ ما هو مجال تخصصك؟

- توحد واضطرابات سلوكية
- إعاقة فكرية
- إعاقة سمعية
- صعوبات تعلم
- اضطرابات نطق وكلام
- إعاقة بصرية

٤- الخبرات التدريسية:

أ- كم عدد السنوات التي امضيتها في التدريس في مدارس رياض الأطفال العادية؟
فضلاً حددي

ب- كم عدد السنوات التي امضيتها في التدريس في معاهد التربية الخاصة؟
فضلاً حددي

ج- كم عدد السنوات التي امضيتها في التدريس في برامج الدمج في المدارس الحكومية؟
فضلاً حددي

٥- كم عدد الأطفال في فصلك الحالي؟
فضلاً حددي

٦- باستثناء نفسك، فضلاً انكري عدد معلمات التربية الخاصة في روضتك؟

فضلاً حددي.....

٧- هل يوجد مساعدة معلمة للأطفال ذوي الإعاقة في صفك الحالي؟

- نعم يوجد
- لا يوجد

٨- هل سبق والتحققت في دورات تدريبية عن التربية الخاصة؟

- نعم
- لا



٩- هل يوجد في أسرته او في أحد أسر اقاربك فرد من ذوي الإعاقة؟

نعم

لا



القسم ٢: كفاءة معلمات رياض الأطفال في ممارسة عملية الدمج

يهدف هذا الاستبيان لمعرفة مدى ثقة المعلمات في كفاءتهن في ممارسة عملية دمج الأطفال ذوي الإعاقة مع الأطفال العاديين في رياض الأطفال العادية.

إرشادات تعبئة جدول الاستبيان

أمل وضع علامة تحت البند الذي يتوافق مع تقضيئك من الخيارات الخمسة
٥ أوافق بشدة، ٤ أوافق، ٣ غير متأكد، ٢ لا أوافق، ولا أوافق بشدة

أرجو الإجابة على جميع العبارات

القسم الثالث: كفاءة المعلمات في ممارسة عملية الدمج					
رقم العبارة	العبارات	لا أوافق بشدة	لا أوافق	غير متأكد	أوافق بشدة
١	استطيع تحديد توقعاتي بدقة عالية حيال سلوك الأطفال.				
٢	يمكنني تهدئة الأطفال الذين يعرقلون سير الدراسة ونوي لنزعة التخريبية أو الذين تصدر عنهم ضجة داخل الصف.				
٣	أعمل على أن يشعر الأهل بالراحة حين قدمهم لزيارة المدرسة. أستطيع مساعدة وإرشاد الأهل ليساعدوا أطفالهم بتحقيق نتائج جيدة في المدرسة.				
٤	أستطيع أن أقيس بدقة مدى فهم الأطفال ولستيعابهم لما أدرسه في الصف.				
٥	أستطيع إعطاء تقييم مناسب لمستوى الأطفال المتمكنين دراسياً.				
٦	أنا واثقة في قدرتي على التنبؤ بالسلوك الغير مرغوب فيه في الصف ومنع حدوثه.				
٧	أستطيع للتحكم والسيطرة على السلوك الغير مرغوب فيه للأطفال ذوي الإعاقة، العاديين داخل الصف.				
٨	أنا أثق في قدرتي على جعل الأهل يشاركون في الأنشطة المدرسية المتعلقة بأبنائهم من ذوي الإعاقة.				
٩	أنا أثق في قدرتي على تصميم مهام وواجبات دراسية يستطيع الأطفال من ذوي الإعاقة متابعتها والتأقلم معها بسهولة.				
١٠	لدي القدرة على جعل الأطفال يلتزمون بالقواعد والقوانين التي أضعها في الصف.				
١١	أستطيع للتأقلم والتعاون مع متخصصات اخريات (أخصائية العلاج الطبيعي، الوظيفي، أخصائية اضطرابات النطق والكلام) في تصميم خطط تعليمية للطلاب من ذوي الإعاقة.				
١٢	أستطيع للعمل مع المعلمات الاخريات (معلمة تربية خاصة أو تعليم عام أو معلمة مساعدة) في تدريس وتعليم الأطفال من ذوي الإعاقة.				
١٣	لدي القدرة على استخدام تقنيات تقييم مختلفة ومتنوعة (اختبارات تحديد المستوى واختبارات الأداء) لتقييم الأطفال.				
١٤	لدي القدرة على جعل الأطفال يعملون بشكل ثنائي أو كمجموعات ويتعاونون مع بعضهم البعض.				
١٥	أثق في قدرتي على تعليم الآخرين القوانين والسياسات المتعلقة بعمليات دمج الأطفال ذوي الإعاقة مع الأطفال العاديين).				

**WESTERN SYDNEY
UNIVERSITY**



					١٧	لدي القدرة على تهدئة الأطفال (ذوي الإعاقة أو العاديين) ذوي الطبيعة التخريبية والعدائية.
					١٨	لدي القدرة على تقديم توضيحات وأمثلة بديلة لتسهيل الفهم عندما يصعب على الأطفال الفهم والاستيعاب.

٢.٢ - ما مدى شعورك بالثقة في قدراتك عند دمج الأطفال ذوي الإعاقة في صفك الدراسي؟ من قائمة الإعاقات أدناه، يرجى ترتيبها حيث رقم (١) يمثل أعلى مستوى من الثقة و (٨) يمثل أقل مستوى من الثقة في قدراتك عند تدريس هؤلاء الأطفال. يرجى وضع رقم معين لكل إعاقة مع مراعاة عدم تكرار هذا الرقم.

أنا أكثر ثقة في قدراتي عند تدريس ودمج الأطفال ذوي:

ترتيب التصنيف	أنواع الإعاقات
	توحد واضطرابات سلوكية
	إعاقة عقلية
	إعاقة سمعية
	صعوبات تعلم
	اضطرابات نطق وكلام
	إعاقة بصرية
	إعاقة حركية
	إعاقات متعددة



القسم ٣. اتجاهات المعلمات نحو دمج الأطفال ذوي الإعاقة بفصول رياض الأطفال العادية

٣.١. يهدف هذا القسم إلى معرفة مدى قناعتك في دمج الأطفال من ذوي الإعاقة في رياض الأطفال العادية مع الأطفال العاديين للدراسة معاً في فصل واحد.

إرشادات تعبئة جدول الاستبيان
أمل وضع علامة تحت البند الذي يتوافق مع تفضيلك من الخيارات الخمسة

أرجو الإجابة على جميع العبارات

رقم العبارة	العبارات	لا أوافق بشدة	لا أوافق	غير متأكد	أوافق	أوافق بشدة
١	يمكن لغالبية الأطفال ذوي الإعاقة بذل الجهد بما فيه الكافية للقيام بالمهام التعليمية في الفصل العادي.					
٢	يتطلب الدمج الشامل للأطفال ذوي الإعاقة إعادة تدريب مكثف لمعلمات التعليم العام.					
٣	يؤدي دمج الأطفال ذوي الإعاقة في الصف العادي إلى تحسين قدرتهم على التفاعل مع الآخرين.					
٤	من المحتمل أن يصدر من الطفل ذوي الإعاقة مشاكل سلوكية داخل الصف المدمج.					
٥	إلحاق ودمج الأطفال ذوي الإعاقة بالصفوف العادية هو أفضل وسيلة لتعليمهم.					
٦	سيؤثر الاهتمام الزائد الذي يحتاجه الأطفال ذوي الإعاقة سلباً على غيرهم من الأطفال.					
٧	دمج الأطفال ذوي الإعاقة في رياض الأطفال العادية سوف يساعدهم على اكتساب المهارات الأكاديمية.					
٨	سيطلب دمج الأطفال ذوي الإعاقة إجراء تغييرات هامة داخل رياض الأطفال العادية.					
٩	قد تحدث زيادة الحرية في الصف الدراسي المدمج ارتباك للأطفال ذوي الإعاقة.					
١٠	المعلمات العاديات قادرات على التعامل مع الأطفال ذوي الإعاقة.					
١١	وجود الأطفال ذوي الإعاقة في الصفوف العادية لن يشجع الأطفال العاديين على قبولهم.					
١٢	سلوك الأطفال ذوي الإعاقة في الفصل العادي يشكل مثلاً سيئاً للأطفال العاديين.					
١٣	يحتمل أن ينمي الأطفال ذوي الإعاقة مهاراتهم الأكاديمية في رياض الأطفال المدمجة أسرع من مراكز ذوي الإعاقة.					
١٤	لن يساعد دمج الأطفال ذوي الإعاقة في رياض الأطفال العادية على تعلم المهارات الاجتماعية.					
١٥	ليس من الصعب المحافظة على نظام الصف العادي الذي فيه أطفال من ذوي الإعاقة مقارناً بالصف الذي يخلو منهم.					



					١٦ لا يحتاج الأطفال ذوي الإعاقة لوقت كبير من معلمات للتعليم العادي عندما يقمن بتعليمهم في الصف العادي.
					١٧ ان دمج الأطفال ذوي الإعاقة مع الأطفال العاديين يعتبر مقبلاً للأطفال العاديين.
					١٨ دمج الأطفال ذوي الإعاقة سوف يحدث بعض المشاكل داخل الفصل العادي.
					١٩ تعد معلمات الصفوف العادية مدربات تدريباً كافياً لتدريس الأطفال ذوي الإعاقة في الصفوف العادية
					٢٠ قد تؤثر عملية الدمج سلباً على النمو الانفعالي للأطفال ذوي الإعاقة.
					٢١ ينبغي أن يعطى الأطفال ذوي الإعاقة كل فرصة للقيام بأية مهام ممكنة داخل الفصل العادي.
					٢٢ لا يتطلب سلوك الأطفال ذوي الإعاقة في الصف العادي من المعلم صبراً أكثر مما يتطلبه سلوك الأطفال العاديين.
					٢٣ معلمت التربية الخاصة فقط هم الذين ينبغي لهم تدريس الأطفال ذوي الإعاقة.
					٢٤ يؤدي عزل الأطفال ذوي الإعاقة في مراكز خاصة بهم إلى تنمية مهاراتهم الاجتماعية والانفعالية.
					٢٥ لا يعتبر الأطفال ذوي الإعاقة معزولين اجتماعياً في رياض الأطفال العادية.

٣.٢ إلى أي مدى توافقين على دمج الأطفال ذوي الإعاقة المحددة أدناه مع الأطفال العاديين في الصف الدراسي العادي؟

رقم الفقرة	العبارة	لا أوافق بشدة	لا أوافق	لا	غير متأكد	أوافق	أوافق بشدة
	الأطفال ذوي التوحد والاضطرابات السلوكية						
	الأطفال ذوي الإعاقة العقلية						
	الأطفال ذوي الإعاقة السمعية						
	الأطفال ذوي صعوبات التعلم						
	الأطفال ذوي اضطرابات النطق والكلام						
	الأطفال ذوي الإعاقات البصرية						
	الأطفال ذوي الإعاقات الحركية						
	الأطفال ذوي الإعاقات المتعددة						



القسم ٤: تصورات معلمات رياض الأطفال حول العوامل التي تعيق دمج الأطفال ذوي الإعاقة في الصف الدراسي العادي

من وجهة نظرك، فضلاً عن من ١ إلى ١٣، حيث رقم (١) يمثل ما تعتبره أهم العوائق و (١٣) يمثل أقل العوائق أهمية لدمج الأطفال ذوي الإعاقة في الصف الدراسي العادي. يرجى وضع رقم معين لكل إعاقة مع مراعاة عدم تكرار هذا الرقم.

أهم عوائق دمج الأطفال ذوي الاحتياجات الخاصة في رياض الأطفال العادية هي:

رقم الفقرة	العوائق	التصنيف
١	قلة ثقة المعلمات في قدرتهن في دعم ودمج الأطفال ذوي الإعاقة في صفين الدراسي.	
٢	طبيعة وشدة إعاقة الأطفال تتحكم في قدرتهم على الاندماج مع الأطفال العاديين في الصف الدراسي العادي	
٣	اتجاهات المعلمات السلبية نحو دمج الأطفال ذوي الإعاقة في الصف الدراسي العادي.	
٤	عدم وجود قوانين وسياسات تتعلق بدمج الأطفال ذوي الإعاقة في رياض الأطفال العادية.	
٥	قلة المعرفة والمهارات لدى المعلمات حول دمج الأطفال ذوي الاحتياجات الخاصة في الصف الدراسي العادي.	
٦	عدم ملائمة البيئة المكانية بالروضة لدمج الأطفال ذوي الإعاقة.	
٧	قلة المناهج والمواد التعليمية التي تدعم تعليم الأطفال ذوي الإعاقة في الصف الدراسي العادي.	
٨	ضعف مشاركة ودعم أسر الأطفال ذوي الإعاقة.	
٩	غياب أو قلة عدد مساعديات المعلمات لدعم الأطفال ذوي الإعاقة في الروضة.	
١٠	عدم وجود الوقت الكافي لدى المعلمات.	
١١	كبر حجم الصف الدراسي العادي الذي يحضره الطفل ذوي الإعاقة.	
١٢	قلة الدعم من مديرة الروضة والمشرفة التربوية لعملية دمج الأطفال ذوي الإعاقة.	
١٣	المعتقدات الدينية والاتجاهات الثقافية السلبية نحو دمج الأطفال ذوي الإعاقة.	

**WESTERN SYDNEY
UNIVERSITY**



هل ترغبى بإجراء مقابلة قصيرة مسجلة صوتياً معك حول موضوع الدراسة؟

نعم

لا

في حالة الإجابة بنعم، أرجو تزويدي بهذه المعلومات لأتمكن من التواصل معك.

الاسم:

الإيميل:

رقم الجوال:

شكراً لتعاونك.

APPENDIX C

Semi-structured Interview Questions

- **Attitudes toward the inclusion of children with disabilities.**

1. To begin, please tell me a little bit about the nature of your job as General Education teacher or Special Education teacher in your inclusive classroom?
2. What does the inclusion of children with disabilities mean to you? Do you believe in it?
3. Have you had a child with disabilities in your classroom? How did you feel about that?
4. Can you tell me, what do you believe to be the most appropriate placement for children with disabilities? And why?

- **Teachers' Self-Efficacy**

5. Can you tell me about the challenges of teaching a child with disability? What do you feel when you face these challenges in the classroom?
6. To what extent do you think you are successful in managing and teaching children with disabilities? If so, how? Would you please give an example?

- **Teachers' perceptions of the enablers and barriers of inclusion**

7. What are the barriers that make it difficult for teachers to include children with disabilities in the inclusive classrooms?

APPENDIX D

Ethical Approval

Locked Bag 1797
Penrith NSW 2751 Australia
Research Engagement, Development and Innovation (REDI)



REDI Reference: H11976
Risk Rating: Low 2 - HREC

HUMAN RESEARCH ETHICS COMMITTEE

20 January 2017

Doctor Katrina Barker
School of Education

Dear Katrina,

I wish to formally advise you that the Human Research Ethics Committee has approved your research proposal H11976 "Saudi Kindergarten Teachers' Self-Efficacy and Attitudes Toward Early Childhood Inclusive Education", until 20 November 2018 with the provision of a progress report annually if over 12 months and a final report on completion.

Conditions of Approval

1. A progress report will be due annually on the anniversary of the approval date.
2. A final report will be due at the expiration of the approval period.
3. Any amendments to the project must be approved by the Human Research Ethics Committee prior to being implemented. Amendments must be requested using the HREC Amendment Request Form: https://www.westernsydney.edu.au/_data/assets/word_doc/0012/1096995/FORM_Amendment_Request.docx
4. Any serious or unexpected adverse events on participants must be reported to the Human Ethics Committee via the Human Ethics Officer as a matter of priority.
5. Any unforeseen events that might affect continued ethical acceptability of the project should also be reported to the Committee as a matter of priority.
6. Consent forms are to be retained within the archives of the School or Research Institute and made available to the Committee upon request.

Please quote the registration number and title as indicated above in the subject line on all future correspondence related to this project. All correspondence should be sent to the email address humaneethics@westernsydney.edu.au.

This protocol covers the following researchers:
Katrina Barker, Danielle Tracey, Samih Alzhrani

Yours sincerely

A blacked-out signature, likely of Professor Elizabeth Deane, used to redact the name of the signatory.

Professor Elizabeth Deane
Presiding Member,
Human Researcher Ethics Committee
Western Sydney University

Saudi Ministry of Education Ethics Approval

وزارة التعليم
الرياض (نات)
إدارة التخطيط والتطوير

الرقم: ٣٨٨٤٩٩٢
بتاريخ: ١٤٣٨/٠٦/٠٨ المرفقات





وزارة التربية والتعليم
Ministry of Education

المملكة العربية السعودية

وزارة التربية والتعليم
(١٩٠)

إدارة العامة للتربية والتعليم بمنطقة الرياض
إدارة التخطيط والتطوير



Planning & Development
إدارة التخطيط والتطوير

" تسهيل مهمة بحث "

سامية بنت بخيت الزهراني	اسم الباحثة
جامعة وسترن سديني - استراليا	الكلية / الجامعة
متطلب دراسة علمية للحصول على درجة الدكتوراه	الغرض من الدراسة
كفاءات وتوجهات معلمات رياض الاطفال نحو دمج الاطفال ذوي الاحتياجات الخاصة برياض الاطفال	عنوان الدراسة
تسهيل مهمة الباحثة في تطبيق أداة الدراسة (استبانة) و (مقابلة بعد موافقة المعلمة) وذلك على عينة البحث معلمات رياض الاطفال في فصول دمج ذوي الاحتياجات الخاصة في مدينة الرياض	نوع التسهيل

حفظها الله

وبعد،

المكرمة / قائدة الروضة

السلام عليكم ورحمة الله وبركاته

بناءً على تعميم معالي وزير التعليم رقم 55/610 وتاريخ 1416/9/17هـ بشأن تفويض الإدارات العامة للتعليم بإصدار خطابات السماح للباحثين بإجراء البحوث والدراسات، وبناءً على تفويض مدير عام التعليم إدارة التخطيط والتطوير في الخطاب ذي الرقم 11/33674823 والتاريخ 1433/4/14هـ بشأن تسهيل مهام الباحثين والباحثات ، وحيث تقدم إلين الباحثة (الموضحة بياناتها أعلاه) بطلب إجراء الدراسة، نأمل تسهيل مهمتها وتزويده بالإحصائيات المطلوبة، مع ملاحظة أن الباحثة يتحمل كامل المسؤولية المتعلقة بمختلف جوانب البحث، ولا يعني سماح الإدارة العامة للتعليم موافقتها بالضرورة على مشكلة البحث أو على الطرق والأساليب المستخدمة في دراستها ومعالجتها.

شاكرين طيب تعاونكم ،،،،،،

عن

مدير إدارة التخطيط والتطوير

المساعدة بـ *بدرية الجبري*

سعود بن راشد آل عبد اللطيف



نوف الجراح

ن / 6

ص / قسم الدراسات والبحوث
ن / الصالح

رمز العملية ت ط 6ع

الإصدار: 1.0

تاريخ الإصدار: 1436/8/5هـ

صفحة 11 من 18

APPENDIX E

Consent and Information Forms for Principals

WESTERN SYDNEY
UNIVERSITY



Consent Form – Principals

Project Title: Saudi Kindergarten Teachers' Self-Efficacy and Attitudes Towards Early Childhood Inclusive Education

I hereby consent to participate in the above named research project.

I acknowledge that:

- I have read the Principal Information Sheet, and have been given the opportunity to discuss the information and my involvement in the project with the researcher/s
- The procedures required for the project and the time involved have been explained to me, and any questions I have about the project have been answered to my satisfaction.

I consent for the data and information provided to be used for this project.

I understand that my involvement is confidential and that the information gained during the study may be published but no information about me will be used in any way that reveals my identity.

I understand that teachers in this study I can withdraw from it at any time without affecting my relationship with the researcher/s, and any organisations involved, now or in the future.

Signed:

Name:

Date:

Return address:

This study has been approved by the Human Research Ethics Committee at Western Sydney University. The ethics reference number is: H 11976

What if I have a complaint?

If you have any complaints or reservations about the ethical conduct of this research, you may contact the Ethics Committee through Research Engagement, Development and Innovation (REDI) on Tel +61 2 4736 0229 or email humanethics@westernsydney.edu.au.

Any issues you raise will be treated in confidence and investigated fully, and you will be informed of the outcome.



Principals Information Sheet – General (Specific)

Project Title: Saudi Kindergarten Teachers' Self-Efficacy and Attitudes Toward Early Childhood Inclusive Education

Project Summary:

The general and special education teachers at your kindergarten are invited to participate in a research study being conducted by Samia Alzahrani (Phd Candidate, School of Education, Western Sydney University) under the Supervision of Dr Katrina Barker and Dr Danielle Tracey, School of Education, Western Sydney University. This study aims to explore Saudi kindergarten teachers' self-efficacy and attitude towards inclusive education and identify the barriers for inclusive education in kindergarten settings.

How is the study being paid for?

The study is being sponsored by Saudi Arabia Higher Education which has provided funding for a PhD scholarship.

What will I be asked to do?

If you agree to participate in this research, your teachers will be asked to complete a short online survey. The survey asks about: 1) teachers' views on including children with disabilities in kindergarten settings (attitude), 2) how well teachers believe they are able to include children with disabilities (self-efficacy), 3) what factors influence teachers' views and beliefs about inclusion, and 4) what do teachers perceive to be the enablers and barriers towards inclusion. A small number of the survey completers will be invited to participate in a follow up semi-structured face-to-face interview, which will ask participants to share their experiences of enablers and barriers experienced towards including children with disabilities in kindergartens.

How much of time will teachers need to give?

The questionnaire will take 15-20 minutes. The interview process will be 30- 40 minutes.

What benefits will I, and/or the broader community, receive for participating?

It will provide you with an opportunity to reflect on how you include children with disabilities in kindergarten and how well you do this. It will also assist you in identifying the enablers and barriers towards inclusion in your workplace. Teachers' contribution to this study will provide the first insights into the self-efficacy levels and attitudes of Saudi kindergarten teachers' towards inclusive education. It will also highlight the key enablers and barriers to including children with disabilities. The findings from this research will assist in identifying strategies aimed at improving teachers' attitudes and enhancing their self-efficacy towards inclusive approaches.

Will the study involve any risk or discomfort for me? If so, what will be done to rectify it?

This study will not involve any risk or discomfort for you and with respect for your opinion if you uncomfortable you may stop at any time.

How do you intend to publish or disseminate the results?

The result will be disseminated through the completion of my PhD thesis, seminars, conference presentations and journal articles. Individual participants will not be identifiable in the result or findings. A general summary of the findings will be sent to you if requested.

Will the data and information that teachers have provided be disposed of?

Please be assured that only the researchers will have access to the raw data teachers provide and that teachers' data will not be used in any other projects. Please note that minimum retention period for data collection is five years post publication. The data and information teachers have provided will be securely disposed of.

Can I withdraw from the study?

Participation is entirely voluntary and you are not obliged to be involved. If you do participate you can withdraw at any time without giving reason.

Can I tell other people about the study?

Yes, you can tell other people about the study by providing them with the chief investigator's contact details. They can contact the chief investigator to discuss their participation in the research project and obtain an information sheet.

What if I require further information?

If you require further information, you can contact Samih Alzhrani via my email 18555211@student.westernsydney.edu.au

If you have more questions or need further explanation at any stage, please feel free to contact me or my supervisor Dr. Katrina Barker on P: +61 2 9772 6243 or email k.barker@westernsydney.edu.au, or Dr Danielle Tracey via email d.tracey@westernsydney.edu.au

What if I have a complaint?

If you have any complaints or reservations about the ethical conduct of this research, you may contact the Ethics Committee through Research Engagement, Development and Innovation (REDI) on Tel +61 2 4736 0229 or email humanethics@westernsydney.edu.au.

Any issues you raise will be treated in confidence and investigated fully, and you will be informed of the outcome.

If you agree to participate in this study, you may be asked to sign the Principals Consent Form. The information sheet is for you to keep and the consent form is retained by the researcher.

This study has been approved by the Western Sydney University Human Research Ethics Committee. The Approval number is **H11976**

APPENDIX F

Consent and Information Forms for Teachers

WESTERN SYDNEY
UNIVERSITY



Consent Form – Teacher

Project Title: Saudi Kindergarten Teachers' Self-Efficacy and Attitudes Towards Early Childhood Inclusive Education

I hereby consent to participate in the above named research project.

I acknowledge that:

- I have read the participant information sheet and have been given the opportunity to discuss the information and my involvement in the project with the researcher.
- The procedures required for the project and the time involved have been explained to me, and any questions I have about the project have been answered to my satisfaction.

I consent to:

- Participating in the survey*
- Participating in an interview*
- Having my information at the interview audio recorded*

I consent for my data and information provided to be used for this project.

I understand that my involvement is confidential and that the information gained during the study may be published but no information about me will be used in any way that reveals my identity.

I understand that I can withdraw from the study at any time without affecting my relationship with the researcher/s, and any organisations involved, now or in the future.

Signed:

Name:

Date:

This study has been approved by the Human Research Ethics Committee at Western Sydney University. The ethics reference number is: H 11976

What if I have a complaint?

If you have any complaints or reservations about the ethical conduct of this research, you may contact the Ethics Committee through Research Engagement, Development and Innovation (REDI) on Tel +61 2 4736 0229 or email humaneethics@westernsydney.edu.au. Any issues you raise will be treated in confidence and investigated fully, and you will be informed of the outcome.



Teacher Information Sheet – General (Specific)

Project Title: Saudi Kindergarten Teachers' Self-Efficacy and Attitudes Toward Early Childhood Inclusive Education

Project Summary:

You are invited to participate in a research study being conducted by Samia Alzahrani (Phd Candidate, School of Education, Western Sydney University) under the Supervision of Dr Katrina Barker and Dr Danielle Tracey, School of Education, Western Sydney University. This study aims to explore Saudi kindergarten teachers' self-efficacy and attitude towards inclusive education and identify the barriers for inclusive education in kindergarten settings.

How is the study being paid for?

The study is being sponsored by Saudi Arabia Higher Education which has provided funding for a PhD scholarship.

What will I be asked to do?

You will be asked to complete a short online survey. The survey asks about: 1) your views on including children with disabilities in kindergarten settings (attitude), 2) how well you believe you are able to include children with disabilities (self-efficacy), 3) what factors influence your views and beliefs about inclusion, and 4) what do you perceive to be the barriers towards inclusion. A small number of the survey completers will be invited to participate in a follow up semi-structured face-to-face interview, which will ask participants to share their experiences of barriers experienced towards including children with disabilities in kindergartens.

How much of my time will I need to give?

The questionnaire will take 15-20 minutes. The interview process will be 30- 40 minutes.

What benefits will I, and/or the broader community, receive for participating?

It will provide you with an opportunity to reflect on how you include children with disabilities in kindergarten and how well you do this. It will also assist you in identifying the enablers and barriers towards inclusion in your workplace. Your contribution to this study will provide the first insights into the self-efficacy levels and attitudes of Saudi kindergarten teachers' towards inclusive education. It will also highlight the key enablers and barriers to including children with disabilities. The findings from this research will assist in identifying strategies aimed at improving teachers' attitudes and enhancing their self-efficacy towards inclusive approaches.

Will the study involve any risk or discomfort for me? If so, what will be done to rectify it?

This study will not involve any risk or discomfort for you and with respect for your opinion if you uncomfortable you may stop at any time.

How do you intend to publish or disseminate the results?

The result will be disseminated through the completion of my PhD thesis, seminars, conference presentations and journal articles. Individual participants will not be identifiable in the result or findings. A general summary of the findings will be sent to the administration of each school if requested.

Will the data and information that I have provided be disposed of?

Please be assured that only the researchers will have access to the raw data you provide and that your data will not be used in any other projects. Please note that minimum retention period for data collection is five years post publication. The data and information you have provided will be securely disposed of.

Can I withdraw from the study?

Participation is entirely voluntary and you are not obliged to be involved. If you do participate you can withdraw at any time without giving reason.

Can I tell other people about the study?

Yes, you can tell other people about the study by providing them with the chief investigator's contact details. They can contact the chief investigator to discuss their participation in the research project and obtain an information sheet.

What if I require further information?

If you require further information, you can contact Samia Alzahrani via my email 18555211@student.westernsydney.edu.au

If you have more questions or need further explanation at any stage, please feel free to contact me or my supervisor Dr. Katrina Barker on P: +61 2 9772 6243 or email k.barker@westernsydney.edu.au, or Dr Danielle Tracey via email d.tracey@westernsydney.edu.au

What if I have a complaint?

If you have any complaints or reservations about the ethical conduct of this research, you may contact the Ethics Committee through Research Engagement, Development and Innovation (REDI) on Tel +61 2 4736 0229 or email humanethics@westernsydney.edu.au.

Any issues you raise will be treated in confidence and investigated fully, and you will be informed of the outcome.

If you agree to participate in this study, you may be asked to sign the Participant Consent Form. The information sheet is for you to keep and the consent form is retained by the researcher/s.

This study has been approved by the Western Sydney University Human Research Ethics Committee. The Approval number is **H 11976**

