Controlling and Monitoring of Temperature and Humidity of Oyster Mushrooms in Tropical Climates

I Gusti Made Ngurah Desnanjaya¹, Putu Sugiartawan^{*2}

¹*Computer Systems Study, Institut Bisnis dan Teknologi Indonesia, Denpasar, Bali, Indonesia*

^{*2}*Information Technology, , Institut Bisnis dan Teknologi Indonesia, Denpasar, Bali, Indonesia*

e-mail: ¹ngurah.desnanjaya@ stiki-indonesia.ac.id, ^{*2}putu.sugiartawan@stiki-indonesia.ac.id

Abstrak

Pengontrolan suhu dan kelembaban budidaya jamur tiram masih dilakukan secara manual yaitu dengan cara menyemprotkan air pada wadah jamur sehingga menghabiskan banyak waktu dan tenaga. Hal itu dilakukan demi memenuhi syarat tumbuh jamur tiram yang sangat dipengaruhi oleh keadaan suhu dan kelembaban agar dapat tumbuh dengan baik. Pada penelitian ini dibuat sebuah alat pengatur dan monitoring suhu serta kelembaban budidaya jamur tiram secara otomatis berbasis arduino UNO. Alat ini dapat mengatur serta memonitoring suhu dan kelembaban yang ada pada budidaya jamur tiram secara otomatis sehingga suhu dan kelembaban dapat terjaga tanpa harus menghabiskan banyak waktu dan tenaga. Komponene yang digunakan dalam membangun alat pengatur dan monitoring suhu serta kelembaban budidaya jamur tiram secara otomatis berbasis arduino UNO ini adalah, sensor dht11, arduino UNO, driver L298N, relay, dan LCD 16x2 I2C. Dari hasil pengujian yang telah dilakukan, didapat kesimpulan bahwa alat pengatur dan monitoring suhu serta kelembaban budidaya jamur tiram secara otomatis berbasis arduino UNO sudah dapat berfungsi dengan baik dalam mengatur dan memonitoring suhu dan kelembaban sesuai dengan yang diharapkan.

Kata kunci— *Arduino UNO, DHT11, LCD, Jamur Tiram*

Abstract

Controlling the temperature and humidity of oyster mushroom cultivation is done manually by spraying air on the mushroom container so it takes a lot of time and effort. This is done to meet the requirements for growing oyster mushrooms which are strongly influenced by temperature and humidity conditions so that they can grow well. In this study, a device for controlling and monitoring the temperature and humidity of oyster mushroom cultivation was made automatically based on Arduino UNO. This tool can regulate and monitor the temperature and humidity in oyster mushroom cultivation automatically so that the temperature and humidity can be maintained without having to spend a lot of time and effort. The components used in building the automatic temperature and humidity controller for mushroom cultivation based on the Arduino UNO are the dht11 sensors, Arduino UNO, L298N driver, relay, and 16x2 I2C LCD. From the results of the tests that have been carried out, it can be concluded that the temperature and humidity control and monitoring device for automatic oyster mushroom cultivation based on Arduino UNO has been able to work well in regulating and monitoring temperature and humidity as expected.

Keywords— *Arduino UNO, DHT11, LCD, Oyster Mushroom*

1. INTRODUCTION

Oyster mushroom cultivation is now well known by the Indonesian people, both in small quantities and in large quantities [1]. However, in cultivating oyster mushrooms, it is arguably not easy because you have to go through several stages, starting from making a mushroom place, making planting media, ripening, sterilizing, cooling, inoculating seeds (planting seeds), incubating, maintaining, to harvesting [2][3]. Proper and regular care will make the fungus thrive, for areas with hot temperatures are more at risk of failure which is quite high when compared to areas with cold climates [4][5][6].

Naturally, mushrooms are found in forests under broadleaf trees or under woody plants that have an ambient temperature of about 16 ° C - 22 ° C and a humidity of 80% - 90% [7][8]. To cultivate oyster mushrooms (*Pleurotus ostreatus*) in lowland areas (temperature \pm 30 ° C), special treatment is required for mushroom barns which control the temperature and humidity in the planting room so that the ideal conditions for fungal growth can be met [9][10][11]. The results of mushroom productivity are very reliable by temperature and humidity conditions because if the temperature and humidity are not suitable, the growth of oysters will be inhibited or even the fungus will not grow [12][13][14].

With the development of current technology, Insyaf is needed in treating oyster mushroom cultivation. In the cultivation of oyster mushrooms, the treatment that is very often done is to help temperature and humidity to remain stable [15][16][17]. The temperature and humidity of the oyster mushroom cultivation is 26 ° - 30 ° C and 70% - 90% RH, to maintain temperature and humidity at this time it is still done manually, namely, by spraying air into the backlog (where oyster mushrooms grow), to maintain temperature and humidity is automatically required to give time and effort [18][19][20][21][22].

In connection with the problems experienced by beetle mushroom cultivation farmers in the tropics, research was carried out on the design of control devices and the monitoring of temperature and humidity of oyster mushrooms. This tool can help monitor temperature and is applied in plant cultivation. oyster mushrooms, so that the temperature and humidity in the oyster mushrooms are still by what the mushrooms need to grow properly, and the owner can monitor the temperature and mushroom settings through gauze. 16x2 I2C LCD.

2. METHODS

Data is one of the most important elements in a study. Without data, research is considered non-existent. To obtain data, data collection was carried out. For the data to obtain adequate quality and validity, data collection is carried out using certain methods, techniques, and instruments. Data collection techniques are techniques or methods used to collect data related to research activities carried out. The types of data collected in this practical work activity are divided into 2, namely primary data and secondary data.

2.1 Primary Data

Primary data is data that is obtained directly from the object of research. In this study, data were obtained using two methods, namely interview (interview), which is the process of collecting data and information by conducting questions and answers with sources who are experts in the field, to obtain the required information. Meanwhile, observation is the process of deliberately or systematically, or systematically observing and recording a series of behaviors and arrangements relating to the topics and problems raised by the author, which will be analyzed later.

2.1.1 Interview

In this study, interviews were carried out with only one person, namely Mr. I Kadek Saputra as the owner of the oyster mushroom cultivation in Butin, Bangli District, Bangli

Regency. From the results of interviews conducted by the author on December 23, 2018, with Mr. I Kadek Saputra. He said that cultivating oyster mushrooms is quite difficult because you has to go through several stages, starting from making, making planting media, ripening, sterilizing, cooling, inoculating the seeds (planting seeds), incubating, maintaining, to harvesting. According to him, the thing that is most often done is to keep the temperature stable, because if the temperature is not suitable then the growth of oyster mushrooms will be hampered and may not even grow, the temperature needed by mushrooms to grow properly is $26^{\circ} - 30^{\circ} \text{C}$ to maintain a constant temperature. as stable as done by spraying water on the bag log.

2.1.2 Observation

In this study, the authors went directly to the oyster mushroom cultivation area measuring 7m in length, 5m in width, and 2.5m in height in Butin, Bangli District, Bangli Regency. The observation is carried out by observing several aspects of the cultivation site such as. Monitor the temperature using a thermometer, spraying water into the long bag to get the desired temperature.

2. 2 Secondary Data

Secondary data collection is collecting data through intermediary media or indirectly in the form of books, records, existing evidence, or archives, both published and not generally published. In other words, researchers need data collection by visiting libraries, study centers, archive centers, or reading many books related to the research being carried out.

2.2.1 Analysis of Data Collection and System Requirements

Collection data through intermediary media or indirectly in the form of books, records, existing evidence, or archives both published and not publicly published. In other words, researchers need data collection by visiting libraries, study centers, archive centers, or reading many books related to the research being carried out. As for women.

2.2.2 Block Diagram

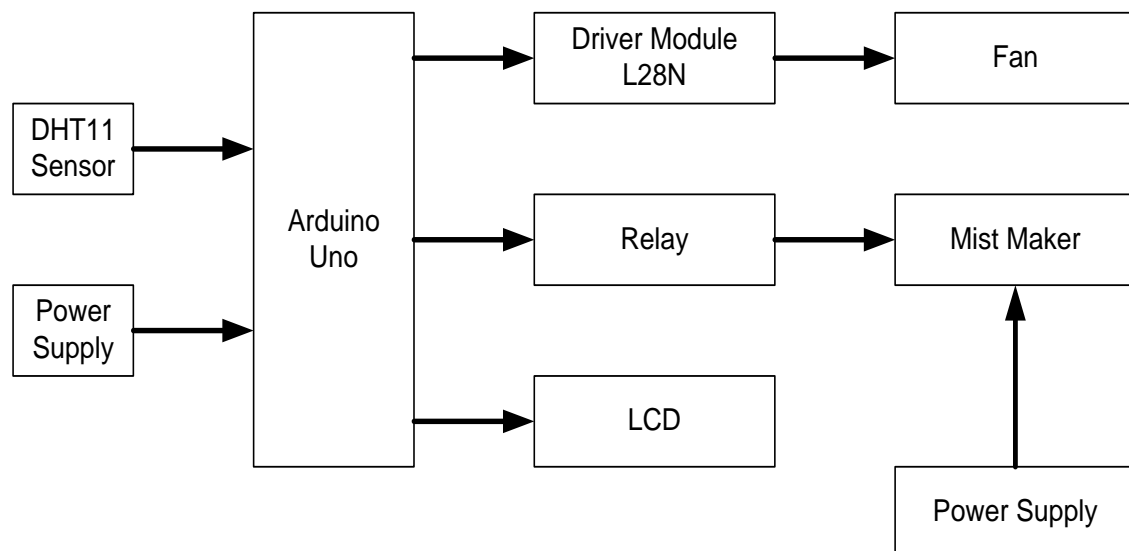

Figure 1. Block Diagram of The System

In designing the tools to be made, we must make it easier to work on them create a working diagram of the whole system. In addition, we can create block diagrams easier to understand the function of each device used to design or build the desired tool. Block diagrams,

tools for controlling and monitoring the temperature and humidity of the oyster mushroom cultivation automatically based on Arduino Uno

2.2.3 Design

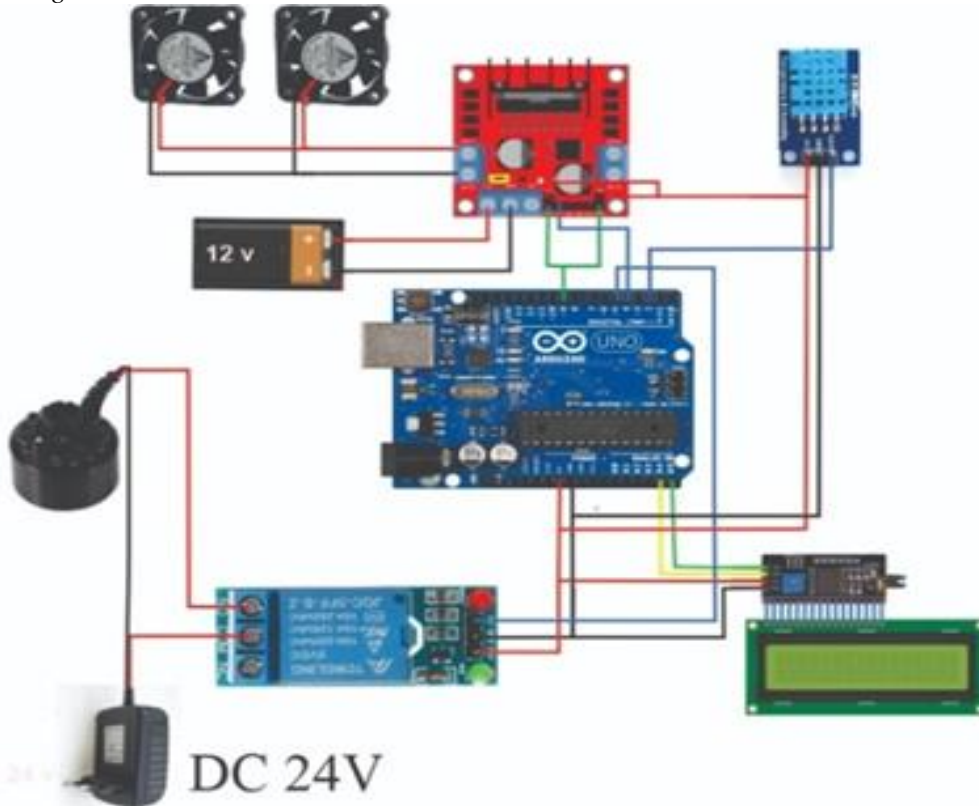

Figure 2. Control Device

can function as expected. The installation of pins on each component is very important because pinning the components is useful for connecting components to one another so that they can communicate with each other. The components that will be explained include pin installation. Installing pins on the Arduino component to the LCD is useful for displaying data, the data that is meant in the form of numbers. Installing pins on the Arduino component to DHT11 is useful for adjusting the temperature and humidity of the oyster mushroom then it will be processed and produce numbers that will be displayed on the LCD. Installing pins on the Arduino component to the Relay serves to deliver or disconnect and connect the electricity in the circuit with control in the form of voltage entering the coil. An explanation of the pin installation can be seen in the table below.

Table 1. Arduino to LCD

Pin LCD 16x2 I2C	PIN Arduino
SCL	A5
SDA	A4
VSS	GND
VDD	VCC

Table 2. Arduino to DHT11

Pin DHT11	Pin Arduino
GND	GND
Data	2
VCC	5V

Table 3. Relay to Arduino

Mist Maker	Pin Relay	Pin Arduino
Cable +	NO and COM	
	IN1	5
	GND	GND
	VCC	5V

3. RESULTS AND DISCUSSION

Testing of each component is carried out to determine whether the components used are functioning or not. The components to be tested are Arduino UNO, DHT11 Sensor, Fan, Mist Maker (fog device), 16x2 LCD, and 1 channel relay.

Arduino UNO testing is carried out to find out whether the Arduino UNO that will be used is functioning normally by trying one of the Arduino UNO pins to turn on an LED. Here the author uses a yellow LED to test the Arduino whether it works as it should or not, the Arduino UNO pins that are used are pin 13 and GND. The yellow LED is programmed to be lit for three seconds and off for three seconds, for Arduino UNO testing it can be seen in Figure 3

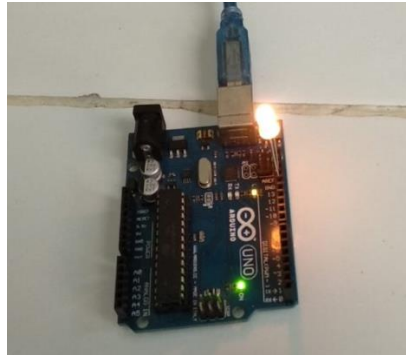

Figure 3. Arduino UNO Testing

DHT11 sensor testing is carried out to determine whether the sensor is functioning properly in temperature and humidity readings by comparing the sensor readings on a serial monitor with the results of thermometer readings that have been proven to be accurate. If the temperature and humidity are not read by the sensor, it means that the sensor used is problematic or damaged, the dht11 sensor test is shown in Figure 4.

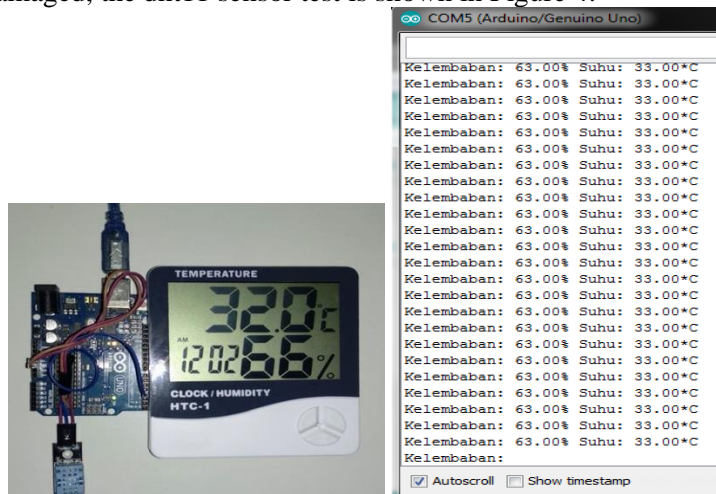

Figure 4. 15 Testing the DHT11

Fan testing is carried out to find out whether the fan that will be used in building an automatic temperature and humidity controller and monitoring device based on Arduino Uno is working well or not. Testing the fan (fan) is done by providing a voltage of 12 volts to the fan (fan), if after being given a voltage of 12 volts the fan (fan) can rotate properly then the fan (fan) is declared feasible to be used in building a regulator and monitoring device. and the humidity temperature of the oyster mushroom is automatically based on Arduino Uno, and vice versa if after the fan is given a voltage of 12 volts but the fan does not rotate, the fan is declared unfit for use and must be replaced immediately. Testing the fan (fan) can be seen in Figure 5



Figure 5. Fan Testing

Mist Maker testing is done to find out whether the Mist Maker that will be used to build the tool is functioning properly or not. The test is done by inserting the Mist Maker into a container filled with water and then given a voltage of 24 volts. The test is shown in Figure 6.



Figure 6 .Testing the Mist Maker

16x2 I2C LCD testing is carried out to determine whether the 16x2 I2C LCD used is functioning properly or not. The pins on the 16x2 I2C LCD to the Arduino UNO pin are the 16x2 I2C LCD GND pin to the Arduino GND pin, the 16x2 I2C LCD VCC pin to the Arduino VCC pin, the 16x2 I2C LCD SDA pin to the Arduino A4 pin, and the SCL pin to the A5 pin on the Arduino. For testing the 16x2 I2C LCD, it is shown in Figure 7.



Figure 7. LCD Testing

Relay testing is done to find out whether the relay that will be used to build the tool is functioning properly or not. The test is carried out by controlling the high-voltage house lamp with the help of low voltage from Arduino, the lamp will be programmed to live for 5 seconds and turn off for 5 seconds. The testing process is shown in Figure 8.











Figure 8. Relay Test

The results of the tests that have been carried out on all the components that will be used to make temperature and humidity control and monitoring tools for oyster mushroom automatically based on Arduino UNO, namely, Arduino UNO is functioning properly as it should because it can turn on the LED, for testing the DHT11 sensor has also functioned well because it can read any temperature changes, then for testing the 16x2 I2C LCD it has also worked very well because it can display the characters on the display according to what is inputted in the program. Testing for the fan (fan) has also worked very well because the fan can rotate when given an electric current, then for testing the Mist Maker (fog device) it has also worked very well because it can produce fog. For testing the L298N driver has worked well because has been able to produce an output in the form of a motor rotation, then the test results from the 12V adapter are already functioning very well because they can supply the Arduino without problems.

The components that are tested on the performance of this tool will be carried out several tests, including the sensitivity of the DHT11 sensor in reading changes in temperature and humidity, as well as testing the 16x2 I2C LCD in displaying the results of the DHT11 sensor readings. For simulation, testing is done by manipulating temperature and humidity to determine the sensitivity of the sensor in reading changes in temperature and humidity.

Table 4. Testing of The Component

NO	Condition	
1		
	The results of the sensor readings in reading the temperature before the temperature is manipulated, namely 33°C.	
2		
	The results of the sensor readings in reading the temperature after the temperature is manipulated by bringing the solder closer to the dht11 sensor for 7 seconds, the result is the sensor reading from a temperature of 33°C to 40°C.	
3		
	The results of the sensor readings in reading humidity before humidity is manipulated by 15%.	
4		
	The results of the sensor readings in reading humidity after humidity is manipulated by applying water to the DHT11 sensor. After 5 seconds the sensor reading results of humidity from 15% to 54%.	

In table 5, the overall test of the tool is carried out where the test is carried out ten times on each condition according to the conditions specified in the program to prove the success of the tool in taking action or decisions.

Table 5. Testing

NO	Test	Condition	Output	Testing to	Status
1	Sensor DHT11	Humidity 91% and 23°C Temperature	Mist maker and fan off	1	Succeed
				2	Succeed
				3	Succeed
				4	Succeed
				5	Succeed
				6	Succeed
				7	Succeed
				8	Succeed
				9	Succeed
				10	Succeed
2	Sensor DHT11	Humidity 61% and Temperature	The mist maker is on and the fan	1	Succeed
				2	Succeed
				3	Succeed

		29°C	is on with a speed of 20% of the maximum speed, which is 255	4	Succeed
				5	Succeed
				6	Succeed
				7	Succeed
				8	Succeed
				9	Succeed
				10	Succeed
3	Sensor DHT11	Humidity 81% and Temperature 30°C	The mist maker is on and the fan is on with a speed of 50% of the maximum speed, which is 255.	1	Succeed
				2	Succeed
				3	Succeed
				4	Succeed
				5	Succeed
				6	Succeed
				7	Succeed
				8	Succeed
				9	Succeed
				10	Succeed
4	Sensor DHT11	Humidity 88% and Temperature 32°C	Mist maker on and fan on at 100% speed	1	Succeed
				2	Succeed
				3	Succeed
				4	Succeed
				5	Succeed
				6	Succeed
				7	Succeed
				8	Succeed
				9	Succeed
				10	Succeed
5	Sensor DHT11	91% Humidity and 26°C Suhu Temperature	Mist maker off and fan on at 20% speed	1	Succeed
				2	Succeed
				3	Succeed
				4	Succeed
				5	Succeed
				6	Succeed
				7	Succeed
				8	Succeed
				9	Succeed
				10	Succeed
6	Sensor DHT11	Humidity 13% and Temperature 25°C	Mist maker on and fan off	1	Succeed
				2	Succeed
				3	Succeed
				4	Succeed
				5	Succeed
				6	Succeed
				7	Succeed
				8	Succeed
				9	Succeed
				10	Succeed

Real tool testing is done by placing one backlog of oyster mushrooms and then observing the growth for several days whether it grows well or not. Figure 9 is the picture of when the oyster mushroom backlog was first inserted into a temperature and humidity control device based on Arduino Uno. After the oyster mushroom laying process, observations will be made on the growth of the oyster mushrooms for several days until the mushrooms are ready to be harvested.

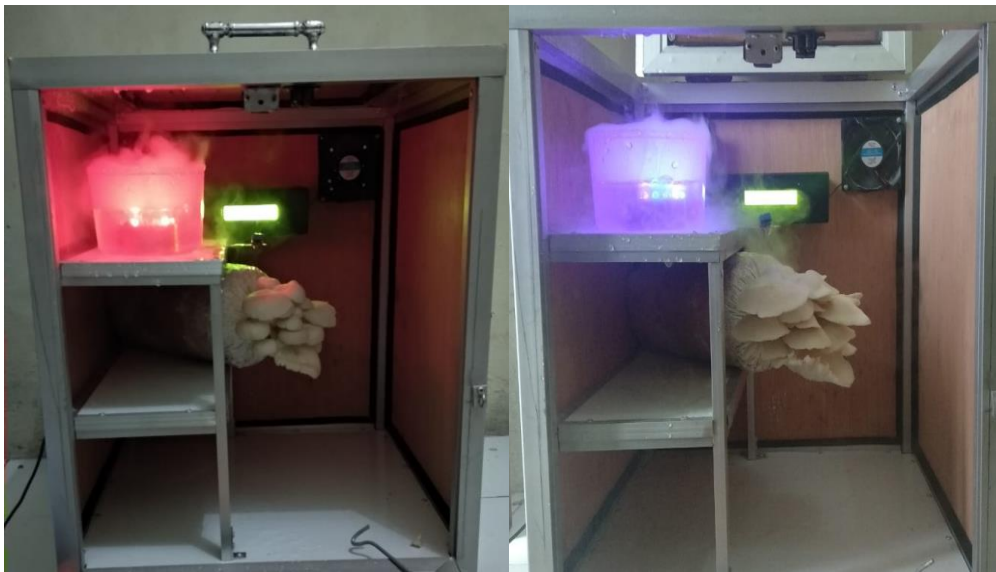

Figure 9. Testing

4. CONCLUSIONS

Based on the results of the research and the results of testing for controlling and monitoring the temperature and humidity of the oyster mushroom automatically based on Arduino Uno, the testing of the tools or performance of the tools for controlling and monitoring the temperature and humidity of the oyster mushroom automatically based on Arduino Uno. It can be concluded that the tool for controlling and monitoring the temperature and humidity of the oyster mushroom automatically based on Arduino Uno can function properly in regulating and monitoring the temperature and humidity of the oyster mushroom. To design and build a device to control and monitor the temperature and humidity of the oyster mushroom, this automatically uses the DHT11 sensor as a temperature and humidity meter, Arduino Uno as a microcontroller or the brain of the tool, the L298N driver as a speed regulator of fan rotation, 16x2 I2C LCD for monitoring temperature and humidity, fan to stabilize temperature, Mist Maker to stabilize humidity, and relays to control high voltage, Mist maker.

ACKNOWLEDGEMENTS

This research has received support from STMIK STIKOM Indonesia through the Institute of Research and Community Service (LPPM), as well as the Institute of Innovation and Creativity Development (LPIK) which has provided research tools and facilities.

REFERENCES

- [1] R. Rozario *et al.*, “CATENARY CURVES-A CASE STUDY Intelligent Mushroom Monitoring System,” 2018.
- [2] T. H. Nasution, M. Yasir, Fahmi, and Soeharwinto, “Designing an IoT system for monitoring and controlling temperature and humidity in mushroom cultivation fields,” in *ICECOS 2019 - 3rd International Conference on Electrical Engineering and Computer Science, Proceeding*, 2019.
- [3] P. Sihombing, T. P. Astuti, Herriyance, and D. Sitompul, “Microcontroller based automatic temperature control for oyster mushroom plants,” in *Journal of Physics: Conference Series*, 2018.
- [4] I. G. M. N. Desnanjaya and I. M. A. Nugraha, “Portable waste capacity detection system

- based on microcontroller and website,” in *Journal of Physics: Conference Series*, 2021, vol. 1810, no. 1.
- [5] L. A. Jones, C. C. Muhlfield, and F. R. Hauer, “Temperature,” in *Methods in Stream Ecology: Third Edition*, 2017.
- [6] S. Waluyo, R. E. Wahyono, B. Lanya, and M. Telaumbanua, “Control Temperature and Humidity in Oyster Mushroom (*Pleurotus* sp) House Automatically Using Microcontroller,” *agriTECH*, 2019.
- [7] M. P. T. Sulistyanto, W. Harianto, D. A. Nugroho, R. E. Retandi, A. K. Akbar, and P. H. Tjahjanti, “The controlling and monitoring system in oyster mushroom cultivation using fuzzy logic through web technology integrated with Internet of Things,” in *MATEC Web of Conferences*, 2018.
- [8] M. Nakano and T. Nagai, “Thermometers for monitoring cellular temperature,” *Journal of Photochemistry and Photobiology C: Photochemistry Reviews*. 2017.
- [9] A. Najmurokhman, Kusnandar, A. Daelami, E. Nurlina, U. Komarudin, and H. Ridhatama, “Development of Temperature and Humidity Control System in Internet-of-Things based Oyster Mushroom Cultivation,” in *2020 3rd International Seminar on Research of Information Technology and Intelligent Systems, ISRITI 2020*, 2020.
- [10] I. N. B. Hartawan, P. P. Santika, I. B. A. I. Iswara, and I. G. M. N. Desnanjaya, “Effect of electromagnetic wave interference against computer network quality of service,” in *Journal of Physics: Conference Series*, 2020.
- [11] C. Kousiatza and D. Karalekas, “In-situ monitoring of strain and temperature distributions during fused deposition modeling process,” *Mater. Des.*, 2016.
- [12] I. M. A. Nugraha, I. G. M. N. Desnanjaya, I. W. D. Pranata, and W. Harianto, “Stability Data Xbee S2b Zigbee Communication on Arduino Based Sumo Robot,” *J. Robot. Control*, 2021.
- [13] H. Fitriawan, K. A. D. Cahyo, S. Purwiyanti, and ..., “IoT based controlling temperature and humidity on oyster mushrooms cultivation.,” *J. Tek. Pertan. ...*, 2020.
- [14] I. G. M. N. Desnanjaya and I. G. I. Sudipa, “The control system of Kulkul Bali based on microcontroller,” in *Proceedings of 2019 5th International Conference on New Media Studies, CONMEDIA 2019*, 2019.
- [15] R. Rozario, “IoT Based Mushroom Monitoring System – A Survey,” *Int. J. Recent Res. Asp.*, 2018.
- [16] M. S. A. Mahmud, S. Buyamin, M. M. Mokji, and M. S. Z. Abidin, “Internet of things based smart environmental monitoring for mushroom cultivation,” *Indones. J. Electr. Eng. Comput. Sci.*, 2018.
- [17] I. Putra, I. P. Putra, M. A. Nasrullah, and T. A. Dinindaputri, “Study on Diversity and Potency of Some Macro Mushroom at Gunung Gede Pangrango National Park,” *Bul. Plasma Nutfah*, vol. 25, no. 2, pp. 77–90, Sep. 2019.
- [18] M. Yamauchi *et al.*, “Cultivation of oyster mushroom (*Pleurotus ostreatus*) on fermented moso bamboo sawdust,” *J. King Saud Univ. - Sci.*, 2019.
- [19] I. Journal, I. Systems, A. Wireless, S. Network, X. P. Series, and X. P. Series, “Performance Analysis of Data Transmission on a Wireless Sensor Network Using the XBee Pro Series 2B RF Module,” vol. 10, no. 2, pp. 211–222, 2020.
- [20] A. N. A. Yahaya, M. S. Hossain, and R. Edyvean, “Analysis of phenolic compounds in empty fruit bunches in oyster mushroom cultivation and in vermicomposting,” *BioResources*. 2017.
- [21] I. G. M. N. Desnanjaya, I. B. A. I. Iswara, A. A. G. Ekayana, P. P. Santika, and I. N. B. Hartawan, “Automatic high speed photography based microcontroller,” in *Journal of Physics: Conference Series*, 2020.
- [22] J. Politowicz *et al.*, “Volatile composition and sensory profile of oyster mushroom as affected by drying method,” <https://doi.org/10.1080/07373937.2016.1274903>, vol. 36, no. 6, pp. 685–696, Apr. 2018.