



Effect Of Using Lead Rubber Bearing On A Steel Arch Bridge

¹Kusumastuti, Dyah; ^{*2}Lim, Erwin; ³Asneindra, Mario; ⁴Mulyadi, Sandy, Silvester

¹ Institut Teknologi Bandung (ITB)

*email: erwinlim@si.itb.ac.id

DOI: <http://dx.doi.org/10.26418/jtsft.v22i1.54494>

Abstract

A study was conducted to evaluate the application of Lead Rubber Bearing (LRB) on bridge structures. The length of steel arch bridge is 80 m, width of 10 m, and height of 19.6 m. The bridge is simply supported with two bearings on each support. Structural analysis reveals that the lateral force on the bearing is more than 400 tons (835 tons in longitudinal direction). The original designer's intention is to use pot bearings. However, the pot bearing was required to undergo some mechanical test to verify its properties prior to installation. Due to its size, this scheme is not applicable due to the limitations of the testing facility. Therefore, an alternative design was evaluated using LRB to reduce the reaction force, hence downsize the bearing size. The LRB used is of LRB 7500 characteristics, and the calculation refers to AASHTO Guide Specifications for Seismic Isolation Design (GSID), 4th edition 2014.

The analysis shows that applying LRB on the bridge lengthened the structural period from 0.76 seconds to 1.67 seconds. It also increased the damping ratio from 5% to 43 %. With these significant changes in structural parameters, lateral forces due to earthquake loads on the bearing and foundation can be greatly reduced. The study found that replacing pot bearings with LRBs can reduce the lateral force to 80 tons, approximately one fifth from the previous design. Correspondingly, the internal forces of some major structural components of the bridge can be reduced due to the application of LRB.

Article History:

Accepted on May 14, 2022

Revised on June 09, 2022

Published on June 17, 2022

Re Published on June 21, 2022

Keyword:

Lead rubber bearing (LRB), Pot bearing, Steel arch bridge, AASHTO guide specifications for seismic isolation design

1. Introduction

The construction of a bridge is important in the development of an area as indicated in a study by Nuh, S. M. (2021). The steel arch bridge being studied in this paper is assumed to be located at West Java. The length of the bridge is 80 m, with a height of 19.6 m and width of 10 m. The isometric view of the steel arch bridge is shown in Fig. 1.

The bridge is a simple span with two supports, i.e., abutment 1 and abutment 2, with two bearings at each abutment. The initial design of the bridge planned to use pot bearings as pinned (2 bearings) on one side and as rolls (2 bearings) on the other. After the design was completed and approved, it is found that the lateral force exerted on the bearing is 835 tons in longitudinal direction. The regulation requires that every bearing must be tested to verify its mechanical properties. With the large forces to be applied on the bearing and the limitation of the test facility, it is deemed not possible to use pot bearing as in the original design. Therefore, an alternative of design using Lead Rubber Bearing (LRB) is proposed. All structural components dimensions for model with LRB follow the original design using pot bearing model.

The LRB calculation refers to AASHTO Guide Specifications for Seismic Isolation Design (GSID) 2014. The specifications are intended for isolation systems that are essentially rigid in vertical direction and isolate in the horizontal plane only.

2. Material Properties

The materials used are steel for the bridge frame and concrete for the slab. The structural steel is JIS SM 490 YB and the standard steel/pipe is JIS SM 400 B / ASTM A53b, while the compressive strength of the concrete is $f_c' = 29$ MPa.

In most applications, isolation systems must be rigid for non-seismic loads but flexible for earthquake loads (to enable required period shift). The LRB mechanical behavior is modeled using a bilinear model as shown in Fig. 2.

Table 1. Isolator properties by manufacturer

No	Description	Formula	Symbol	Unit	Value
1	Yielding displacement	$Q_d / (K_l - K_r)$	d_y	mm	9.00
2	Total yielding load	$Q_d + K_r * d_y$	F_y	kN	431.19
3	Horizontal load at maximum displacement	$Q_d + K_r * d_{max}$	F_{max}	kN	1183.08
4	Effective stiffness at maximum displacement	F_{max} / d_{max}	$K_{eff,max}$	kN/mm	3.79

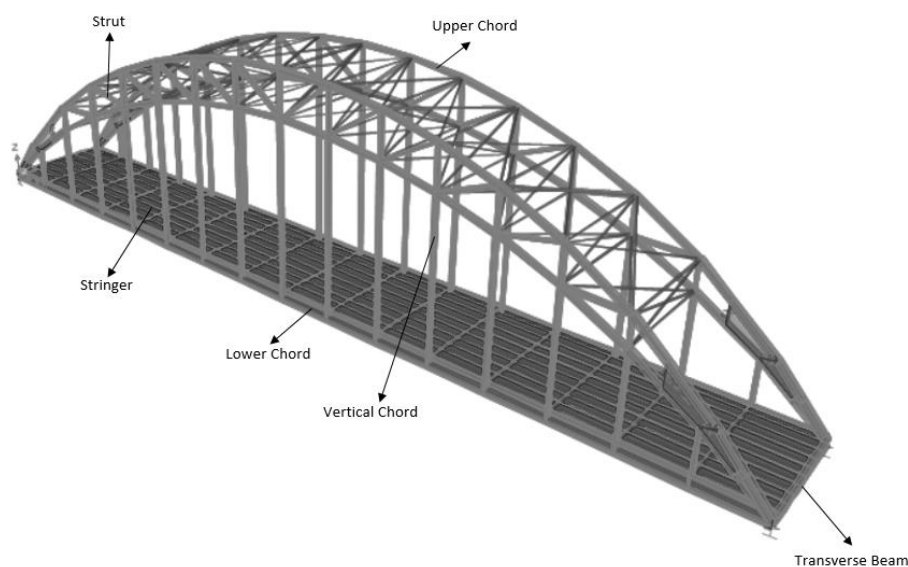

Fig.1 Isometric view of steel arch bridge

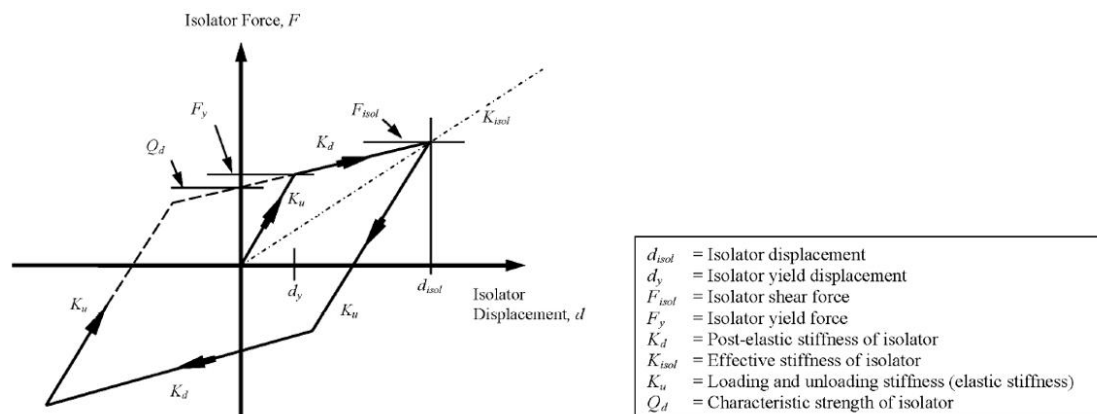

Fig.2 Properties of a bilinear isolator (AASHTO GSID, 2014)

3. Methodology

Although a nonlinear approach should be used to obtain better results, an approximated approach using linear analysis, of which equivalent linear springs and viscous damping are used to represent the isolators, are used in this study to determine the structural responses. The methodology adopts the simplified method to obtain initial estimates of the displacement to be used in an iterative solution involving the multimode spectral analysis method. The earthquake load is based on SNI 2833:2016, while other loads are taken from SNI 1725: 2016. In addition, for steel design, SNI 1729:2020 is used as main reference. Commercial software SAP 2000 which is widely used, such as in Murwanto and Priadi (2015), is used as the analysis tool.

3.1 Simplified Method

A single degree of freedom model of bridge, with equivalent linear properties and viscous dampers to represent the isolators, is analyzed iteratively to obtain estimated superstructure displacement (d_{isol} in Fig. 2, replaced by d to include substructure displacement) and required properties of isolators necessary to give the specified performance.

The simplified method steps as stipulated by AASHTO GSID (2014) are rewritten as follows for completeness and ease of reference:

Step 1: Initial system displacement and properties. To begin the iterative process, an estimate is required of: structure displacement, characteristic strength (Q_d) and post-yield stiffness (K_d).

Step 2: Initial isolator properties at supports. Calculate the characteristic strength ($Q_{d,j}$) and post-elastic stiffness ($K_{d,j}$) of the isolation system at each support “j” by distributing the total calculated strength (Q_d) and stiffness (K_d) values in proportion to the dead load applied at that support:

$$Q_{d,j} = Q_d \left(\frac{W_j}{w} \right)$$

and

$$K_{d,j} = K_d \left(\frac{W_j}{w} \right)$$

Step 3: Effective stiffness of isolator system. Calculate the effective stiffness (K_{eff}) of each support “j” for all supports, taking into account the stiffness of isolators at support “j” ($K_{isol,j}$) and the stiffness of the substructure ($K_{sub,j}$). For the abutments, take $K_{sub,j}$ to be a large number, unless actual stiffness values are available.

$$K_{eff,j} = \frac{\alpha_j K_{sub,j}}{1 + \alpha_j}$$

where

$$\alpha_j = \frac{K_{d,j}d + Q_{d,j}}{K_{sub,j}d - Q_{d,j}}$$

Step 4: Total effective stiffness. Calculate the total effective stiffness (K_{eff}) of the bridge.

$$K_{eff} = \sum_{j=1}^m K_{eff,j}$$

Step 5: Isolation system displacement at each support. Calculate the displacement of the isolation system:

$$d_{isol,j} = \frac{d}{1 + \alpha_j}$$

Step 6: Isolation system stiffness of the isolation system at support “j”, ($K_{isol,j}$) for all supports:

$$K_{isol,j} = \frac{Q_{d,j}}{d_{isol,j}} + K_{d,j}$$

Step 7: Substructure displacement at each support. Calculate the displacement of substructure “j”, ($d_{sub,j}$) for all support:

$$d_{sub,j} = d - d_{isol,j}$$

Step 8: Lateral load in each substructure support. Calculate the shear at support “j”, ($F_{sub,j}$) for all supports:

$$F_{sub,j} = K_{sub,j}d_{sub,j}$$

Step 10: Effective period and damping ratio. Calculate the effective period, (T_{eff}) and viscous damping ratio (ξ) of the bridge:

$$T_{eff} = 2\pi \sqrt{\frac{W_{eff}}{gK_{eff}}}$$

and

$$\xi = \frac{2 \sum_j [Q_d(d_i - d_y)]}{\pi \sum_j [K_{eff,j}(d_i + d_{sub})^2]}$$

Step 11: Damping factor. Calculate damping factor (B_L) and the displacement (d) of the bridge:

$$B_L = \begin{cases} \left(\frac{\xi}{0.05} \right)^{0.3} & \xi < 0.3 \\ 1.7 & \xi \geq 0.3 \end{cases}$$

and

$$d = \frac{9.79 S_{D1} T_{eff}}{B_L}$$

Step 12: Convergence check. Compare the new displacement with the initial value assumed in step 1. If there is close agreement, go to next step; otherwise repeat the process from Step 3 with the new value for displacement as the assumed displacement.

3.2. Multimode Spectral Analysis Method

For the completeness of discussion and ease for reference, the following section is quoted from AASHTO GSID (2014). For the multimode spectral analysis method, the five percent damped ground-motion spectrum shall be used. The scaled spectrum may be obtained using the damping coefficient (B_L) to include the effective damping of the isolation system for the isolated modes. Scaling by the damping coefficient B_L shall apply only for periods greater than $0.8 T_{eff}$. The five percent damped response spectrum shall be used for all other modes. The effective linear stiffness of the isolators shall correspond to the design displacement. Structure system damping shall include all structural elements and obtained by a rational method. The combination of orthogonal seismic forces shall be as specified in Design Specification.

In the multimode spectral analysis method, a three-dimensional multi-degree-of-freedom model of the bridge, with equivalent linear springs and viscous dampers to represent the isolators, is analyzed iteratively to obtain final estimates of superstructure displacement and required properties of each isolator to satisfy performance requirements. The results from the simplified method are used to determine initial values for the equivalent spring elements for the isolators as starting point in the iterative process. The design response spectrum is modified for the additional damping provided by the isolators and applied in longitudinal direction of bridge.

Step 1: Characteristic strength. Calculate the characteristic strength ($Q_{d,j}$) and post-elastic stiffness ($K_{d,j}$) of each isolator “i” as follows:

$$Q_{d,j} = \left(\frac{Q_{d,j}}{n} \right)$$

and

$$K_{d,j} = \left(\frac{K_{d,j}}{n} \right)$$

Where values for $Q_{d,j}$ and $K_{d,j}$ are obtained from final cycle of iteration in the simplified method.

Step 2: Initial stiffness and yield displacement. Calculate the initial stiffness ($K_{u,i}$) and the yield displacement ($d_{y,i}$) for each isolators “i” as follows:

- (1) For friction-based isolators: $K_{u,i} = \infty$ and $d_{y,i} = 0$
- (2) For other types of isolators, and in absence of isolator-specific information, take

$$K_{u,i} = 10K_{d,i}$$

and

$$d_{y,i} = \frac{Q_{d,i}}{K_{u,i} - K_{d,i}}$$

Step 3: Isolator effective stiffness. Calculate the isolator stiffness, ($K_{isol,i}$) of each isolator “i”:

$$K_{isol,i} = \frac{K_{isol,j}}{n}$$

Step 4: Three-dimensional bridge model. Using computer-based structural analysis software, create a three-dimensional model of the bridge with the isolators represented by spring elements.

Step 5: Composite design response spectrum. Modify the response spectrum to obtain a “composite” response spectrum. This is done by dividing all spectral acceleration values at period above $0.8 \times$ the effective period of the bridge (T_{eff}) by the damping factor (B_L).

Step 6: Multimode analysis of finite element model. Input composite response spectrum as a user-specified spectrum in software and define a load case in which spectrum is applied in the longitudinal direction. Analyze the bridge for this load case.

Step 7: Convergence check. Compare the resulting displacements at the superstructure level (d) to the assumed displacements. If in close agreement, go to step 9. Otherwise, go to step 8.

Step 8: Update $K_{isol,i}$, $K_{eff,j}$, ζ , and B_L . Use the calculated displacements in each isolator element to obtain new values of $K_{isol,i}$ for each isolator as follows:

$$K_{isol,i} = \frac{Q_{d,i}}{d_{isol,i}} + K_{d,i}$$

Recalculate $K_{eff,j}$:

$$K_{eff,j} = \frac{K_{sub,j} \sum K_{isol,i}}{(K_{sub,j} + \sum K_{isol,i})}$$

Recalculate system damping ratio, ζ :

$$\xi = \frac{2 \sum_j \sum_i [Q_{d,i}(d_{isol,i} - d_{y,i})]}{\pi \sum_j \sum_i [K_{eff,j}(d_{isol,i} + d_{sub,j})^2]}$$

Recalculate system damping factor, B_L :

$$B_L = \begin{cases} \left(\frac{\xi}{0.05}\right)^{0.3} & \xi < 0.3 \\ 1.7 & \xi \geq 0.3 \end{cases}$$

Obtain the effective period of the bridge from the multimode analysis and with revised damping factor, construct a new composite response spectrum.

Step 7: Convergence check. Compare the resulting displacements at the superstructure level (d) to the assumed displacements. If in close agreement, go to step 9. Otherwise, go to step 8.

Step 9: Once convergence has been reached, obtain superstructure and isolators displacements in the longitudinal and transverse directions of the bridge.

3.3. Isolator Parameter

Based on multimode analysis last iteration, updated values for $K_{isol,i}$ are given below (previous values are in parentheses):

$$K_{isol,1} = 5216.9 (5148.7) \text{ kN/m}$$

$$K_{isol,2} = 5216.9 (5148.7) \text{ kN/m}$$

$$K_{isol,3} = 5216.9 (5148.7) \text{ kN/m}$$

$$K_{isol,4} = 5216.9 (5148.7) \text{ kN/m}$$

Update values for K_{eff} , ζ , B_L , and T_{eff} are given below (previous cycle calculated values are shown in parentheses):

$$K_{eff,1} = 10372 (10237) \text{ kN/m}$$

$$K_{eff,2} = 10372 (10237) \text{ kN/m}$$

$$K_{eff,3} = 10372 (10237) \text{ kN/m}$$

$$K_{eff,4} = 10372 (10237) \text{ kN/m}$$

$$\zeta = 43 \text{ percent (43 percent)}$$

$$B_L = 1.70 (1.70)$$

$$T_{eff} = 1.67 (1.68) \text{ s}$$

Reanalysis gives the following values for the isolator displacement (numbers in parentheses are from previous cycle):

$$d_{isol,1} = 0.149 (0.151) \text{ m}$$

$$d_{isol,2} = 0.149 (0.151) \text{ m}$$

$$d_{isol,3} = 0.149 (0.151) \text{ m}$$

$$d_{isol,4} = 0.148 (0.151) \text{ m}$$

Based on calculations using the simplified method and multimode spectral analysis method, the final value of the isolator effective stiffness ($K_{isol,i}$) is 5216.90 kN/m. This value is utilized as the equivalent linear springs in each direction under consideration. Then, the response spectrum is modified by dividing all spectral acceleration values at period above $0.8 T_{eff}$ by the damping factor (B_L) of 1.70 to obtain composite response spectrum in the last iteration.

Next, combined results from longitudinal and transverse analysis using the (1.0L + 0.3T) and (0.3L + 1.0T) are used to obtain design values for isolator and superstructure displacements. The total design displacement is the governing resultant displacement at an isolator unit obtained from the results of two load cases, i.e. (1.0L + 0.3T) and (0.3L + 1.0T).

The resultant isolator displacements for each load case are calculated from the specified combinations of the maximum longitudinal and transverse displacements from two analyses, one in the longitudinal direction and the other in the transverse. The total design displacement is the largest of the resultant displacements from the two load cases (Fig. 3.). The displacement of the final iteration ($d_{isol,i}$) is close to the previous iteration as shown in Table 2.

The three-dimensional steel arch bridge modeled with the isolators represented by spring elements using the multimode spectral analysis method is shown in Fig. 4.

Table 2. Convergence check in the final iteration cycle

Step	B2.1	B2.1	B2.3	B2.8	B2.8	B2.6	
	First iteration			Final Iteration			
	$Q_{d,i}$	$K_{d,i}$	$K_{isol,i}$	$K_{isol,i}$	$K_{eff,j}$	$Prev$	$d_{isol,i}$
	kN	kN/m	kN/m	kN/m	kN/m	m	m
Abutment 1	409	2500	7729.64	5216.90	10372.01	0.151	0.149
Abutment 2	409	2500	7729.64	5216.90	10372.01	0.151	0.149

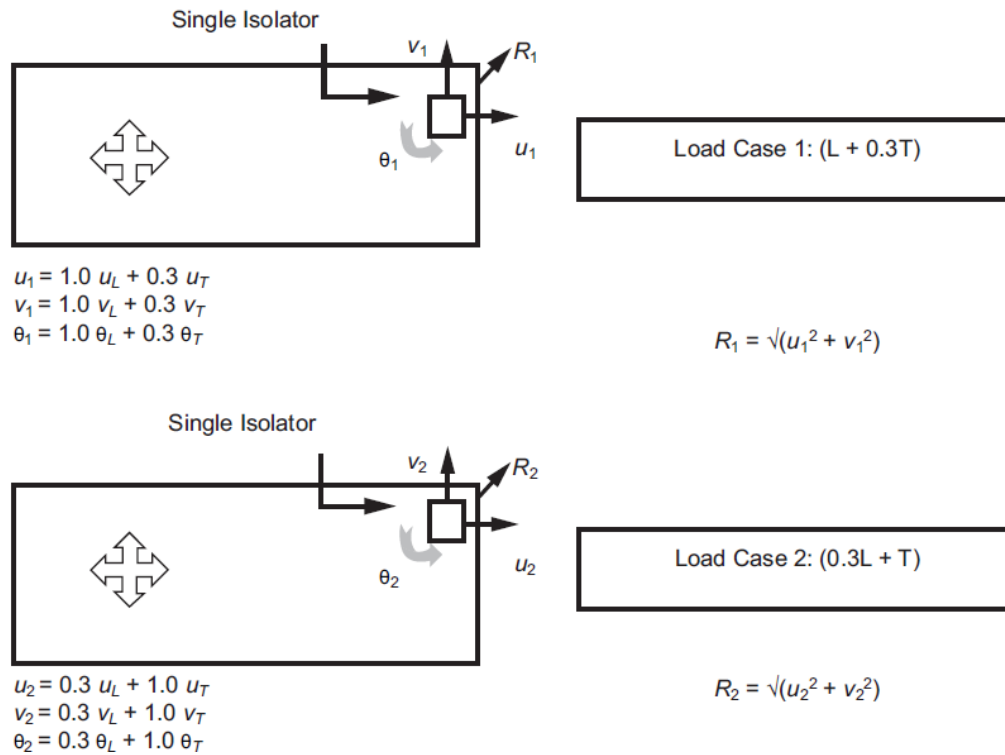

Fig.3 Total design displacement = max [R_1, R_2] (AASHTO GSID, 2014)

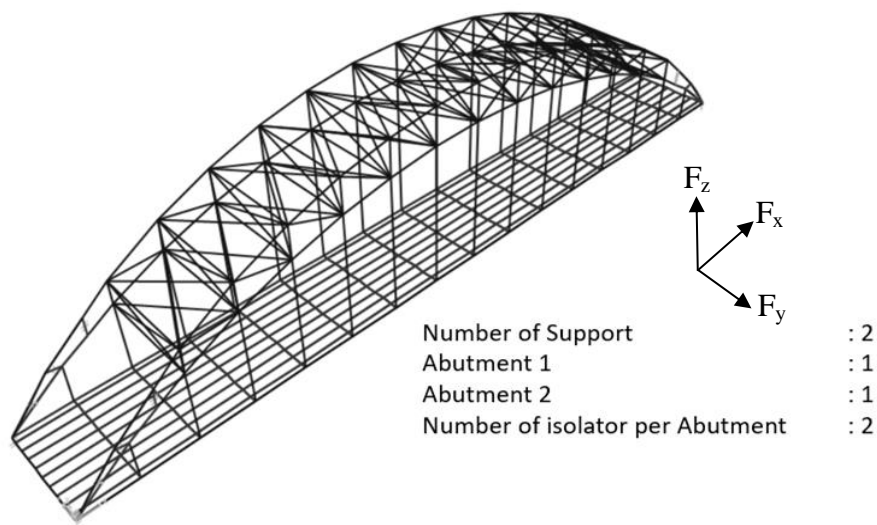

Fig.4 Three-dimensional steel arch bridge model

4. Results and Discussion

Based on the results of the final iteration (after convergence), the period of the bridge structure shifted from 0.76 seconds (pot bearing model) to 1.67 seconds (LRB model). The composite design response spectrum used in the final iteration is illustrated in Fig. 5. The isolator bilinear curve in the final iteration meets the isolator bilinear curve of LRB 7500 (Fig. 6). In addition, the lateral force and lateral displacement of the isolator does not exceed the maximum force capacity and the maximum displacement capacity of the LRB 7500 isolator. The forces obtained from the analysis of the superstructure that will be resisted by the bridge bearing can be summarized as follows:

Abutment 1:

$F_z = 5148 \text{ kN}$ (gravity),

$F_x = 790 \text{ kN}$ (longitudinal), and

$F_y = 687 \text{ kN}$ (transverse)

Abutment 2:

$F_z = 5148 \text{ kN}$ (gravity),

$F_x = 790$ (longitudinal), and

$F_y = 687 \text{ kN}$ (transverse)

It is worth noticing that replacing the pot bearing with LRB can reduce the lateral force on bearings from more than 400 tons (835 tons in longitudinal direction) for non-isolated bridge to less than 80 tons for isolated bridge (LRB). This is due to the longer structural period and the use of the composite design response spectrum.

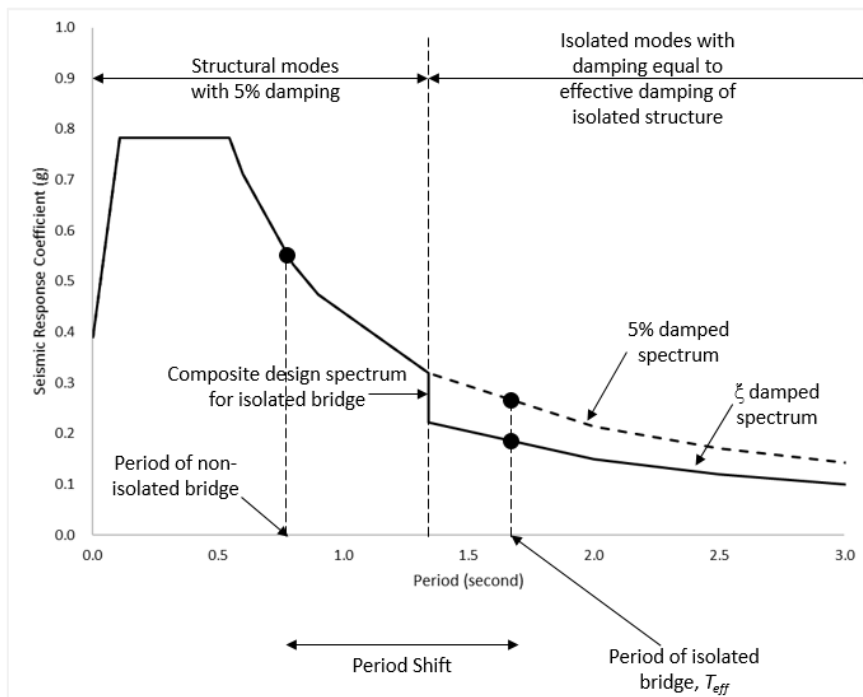

Fig.5 Composite design response spectrum

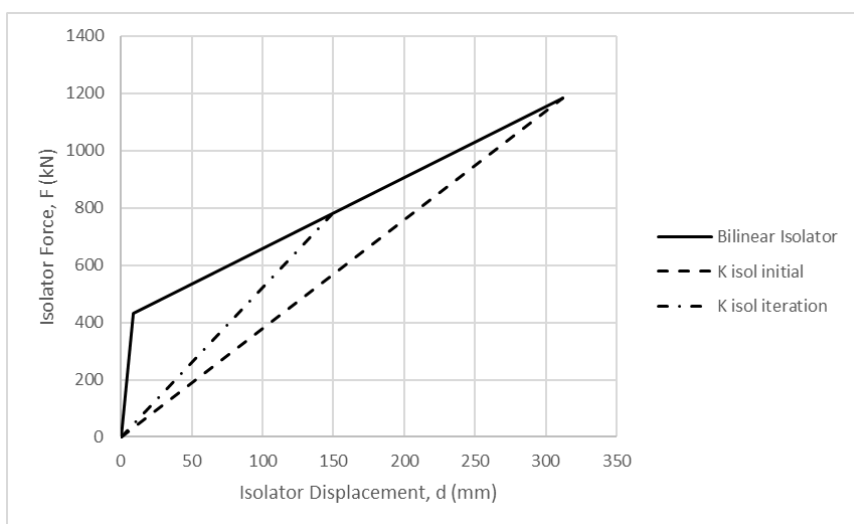

Fig.6 Bilinear isolator of LRB 7500

The combined results from longitudinal and transverse analyses of the bridge using the LRB 7500 shows that the displacement of the LRB due to extreme load combinations does not exceed the amplified displacement (1.25 x design displacement) of LRB 7500 specification. The displacements are presented in Table 3.

As can be seen in Table 3, the maximum displacement in both longitudinal and transverse direction are 153 mm and 132 mm, respectively. Hence, the analysis show that the displacement demand obtained from the analysis is still smaller than the amplified displacement capacity of the isolator, i.e., 312.5 mm.

Utilizing similar components as in the original design, the elements of superstructure are then evaluated. The loading combination used for design refer to SNI 1725:2016 and SNI 2833:2016. After reanalysis of the LRB model, results reveal that the internal forces can be reduced for the steel components, indicated by the demand-to-capacity (DCR) values, given in Table 4. From the obtained DCR values, a significant reduction is achieved for lower chords, struts, and vertical chords. The DCR value of the lower chord reduces from 0.98 (pot bearing model) to 0.62 (LRB model), and the DCR value for strut shows a reduction from 0.75 to 0.40 for pot and LRB model, respectively.

Table 3. Displacement of an isolator

Joint	Max. Displacement		Amplified Displacement	Result
	Longitudinal	Transverse		
	mm	mm	mm	
1	153.16	131.81	312.50	OK
2	152.96	130.90	312.50	OK
3	152.96	130.90	312.50	OK
4	153.16	131.81	312.50	OK

Table 4. Maximum demand-to-capacity ratio (DCR) of major steel bridge components

No.	Component	DCR (Lead Rubber Bearing)	DCR (Pot Bearing)	DCR \leq 1.0
1	Lower Chord	0.62	0.98	OK
2	Transverse Beam	0.85	0.82	OK
3	Stringer	0.73	0.73	OK
5	Upper Chord	0.81	0.87	OK
6	Strut	0.40	0.75	OK
7	Vertical Chord	0.68	0.87	OK

5. Conclusion

The use of LRB on the steel arch bridge evaluated in this study reveals that a significant change in lateral forces of bearing can be obtained. A reduction of the lateral force on bearing that was previously more than 400 tons (835 tons in longitudinal direction) for non-isolated bridge, to less than 80 tons for isolated bridge (LRB). This reduction could also lead to a more economical design of the foundation system. In addition, the evaluation of both lateral force and displacement of the isolator shows that it conforms to the maximum force and displacement capacity of the isolator LRB 7500. Using the composite response spectrum, the application of LRB lengthens the structural period and increases the damping ratio which eventually results in reduction of internal forces of the major structural components reflected in the reduction of their DCR ratios.

6. Authors' Note

The authors declare that there is no conflict of interest regarding the publication of this article. Authors confirmed that the paper was free of plagiarism.

7. References

- American Association of State Highway and Transportation Officials. (2014). **Guide Specifications for Seismic Isolation Design, 4th edition**. Washington DC.
- American Association of State Highway and Transportation Officials. (2017). **LRFD Bridge Design Specifications**. Washington DC.
- Badan Standarisasi Nasional. (2016). **SNI 1725:2016 Pembebanan Untuk Jembatan**. Jakarta.
- Badan Standarisasi Nasional. (2016). **SNI 2833:2016 Perencanaan Jembatan Terhadap Beban Gempa**. Jakarta
- Badan Standarisasi Nasional. (2020). **SNI 1729:2020 Spesifikasi Untuk Bangunan Gedung Baja Struktural**. Jakarta.
- Murwanto, Y. and Priadi, E. (2015). **Kajian Lendutan pada Jembatan Rangka Baja (Studi Kasus Jembatan Rangka Baja Bika Kabupaten Kapuas Hulu)**. Journal of Civil Engineering, University of Tanjungpura, Vol 15, No. 2.

Nuh, S. M. (2021). **Analisis Kelayakan Ekonomi Pembangunan Jembatan Melawi di Kabupaten Melawi.** Journal of Civil Engineering, University of Tanjungpura, Vol. 21, No. 1.