

Studies on the Use of Radioisotopes for the Control of the Red Palm Weevil, *Rhynchophorus ferrugineus* F. by the Sterile Insect Technique.

I. Preliminary investigations on the detection of radiolabelled weevils.

W. J. KLOFT⁺, E. S. KLOFT⁺, P. KANAGARATNAM* and J. L. J. G. PINTO*

⁺ University of Bonn, West Germany

* Coconut Research Institute, Lunuwila, Sri Lanka.

ABSTRACT

Preliminary radioecological investigations were carried out and a technique for labelling red palm weevil with radioisotopes emitting γ radiation was developed. The weevils were tagged by inserting pieces of radioactive Iridium wire, ^{192}Ir into the flight muscles. With a flight carousel it was shown that tagging in this manner did not affect the ability of weevils to fly. The distances upto which marked weevil could be located were estimated. At a distance of 18m, the activity was reduced to approximately 30-40 %. Thus it is possible to detect labelled weevils at a considerably long distance.

The half thickness of fresh and dry coconut timber for radiation emitted by radioactive Iridium, ^{192}Ir and for radioactive Iodine, ^{131}I were also determined. The range of detection of radiation traversing through a coconut trunk was larger for ^{131}I than for ^{192}Ir . However ^{192}Ir was chosen for the tagging because of its longer half-life and as Iridium wire could be cut into small pieces of the required length for labelling the weevils.

INTRODUCTION

Red palm weevil is a serious pest of coconut in Sri Lanka. Harmful systemic insecticides have to be used to treat the weevil infested palms. However as grubs of the weevil feed on the tissues inside the trunk or crown and are not visible from outside, early detection of infested palms is difficult. Hence the damage is often fatal.

Kloft (1984) reported that the Sterile Insect Technique (S.I.T.) is highly specific to the target pest and its use for pest control would minimise environmental disturbances within balanced ecosystems. Very intensive studies on the biology and behaviour of the target insect is a prerequisite to the use of S.I.T. For these studies, a convenient method of marking of insects with radioisotopes would be very useful as radiolabelled insects could be located by using radiation detectors.

Rahalkar *et al* (1971) reported the work carried out in labelling adults of this weevil with Cerium for detection by Neutron activation analysis. However, only γ emitting sources allow detection at a distance and through obstructions (Kloft, 1977 & 1984).

Kloft *et al.* (1964 & 1965) demonstrated that it was possible to detect the movements of wood-boring ants, when labelled with radioiodine, ^{131}I , emitting-rays.

In the present study, some preliminary radioecological experiments with the red palm weevil were carried out. The decrease in the intensity of the-radiation with the distance traversed through coconut palm timber was worked out, and the range of detection of radiolabelled weevils was determined. Kloft (1977) pointed out that laboratory simulated radioecological experiments should be carried out before radiolabelled insects are released in the field. The problems encountered in locating labelled weevils among a large number of unmarked weevils and the fitness of labelled weevils for normal movement and flight were checked and demonstrated under laboratory conditions.

MATERIALS & METHODS

The radioisotopes used in the studies were radioactive, ^{131}I as Sodium iodide and Platinum clad radioactive Iridium, ^{192}Ir wire. The latter was available as a 500 mm coil, 0.3 mm in diameter with a total activity of 150 mCi. Two portable Polyradiometers, IPAB 71 with IPAB 7-1 probes (Gamma Scintillator Probes Na I) were used as measuring equipment. Adult weevils were obtained from those reared in the insectary of the Coconut Research Institute, Lunuwila. Special methods are reported under the relevant experiments.

EXPERIMENTAL

Technique of tagging weevils

Attempts were made to fix small pieces of wire of radioactive Iridium, ^{192}Ir with rubber cement (glue) to the lower surface of the weevil's elytra. The elytrae were partially spread by anaesthetising the weevils with carbon dioxide. However the glued pieces of wire did not adhere satisfactorily and this technique was unsuccessful.

Adult weevils were successfully labelled by inserting small pieces of Iridium wire into the flight muscles in the thorax. However precise lengths of wire could not be cut as the wire was hard.

Ability of radiolabelled weevils to fly

On account of the insertion of the wire into flight muscles, the fitness of labelled weevils for normal movement and flight was checked under laboratory conditions. For this purpose, a flight carrousel was made and the weevil was attached to it by a thin piece of copper wire tied around the thorax. A styrofoam ball was placed beneath the weevil which responded by clasping the ball with its legs. When the weevil loses its grip and the styrofoam ball drops, it will move the carrousel in suspended flight (Fig. 1). Due to the so called tarsal reflex, weevils having no more ground contact tend to fly.

With this arrangement, it was shown that the labelled weevils, inserted with a piece of radioactive Iridium into their thorax could fly as well as the unlabelled weevils.

Location of labelled weevils.

Radiolabelled weevils among a large number of unmarked weevils were placed in a cage. The cage 100 cm \times 150 cm had a wooden frame with wire mesh on all the sides. Attempts were made to detect the radiolabelled weevils using the gamma probes. However this was not possible on account of their design. These probes were sensitive to γ radiation reaching it from various directions. It was therefore not possible to pinpoint the labelled weevils. To overcome this problem, the probe was fitted with an iron shield to cover the

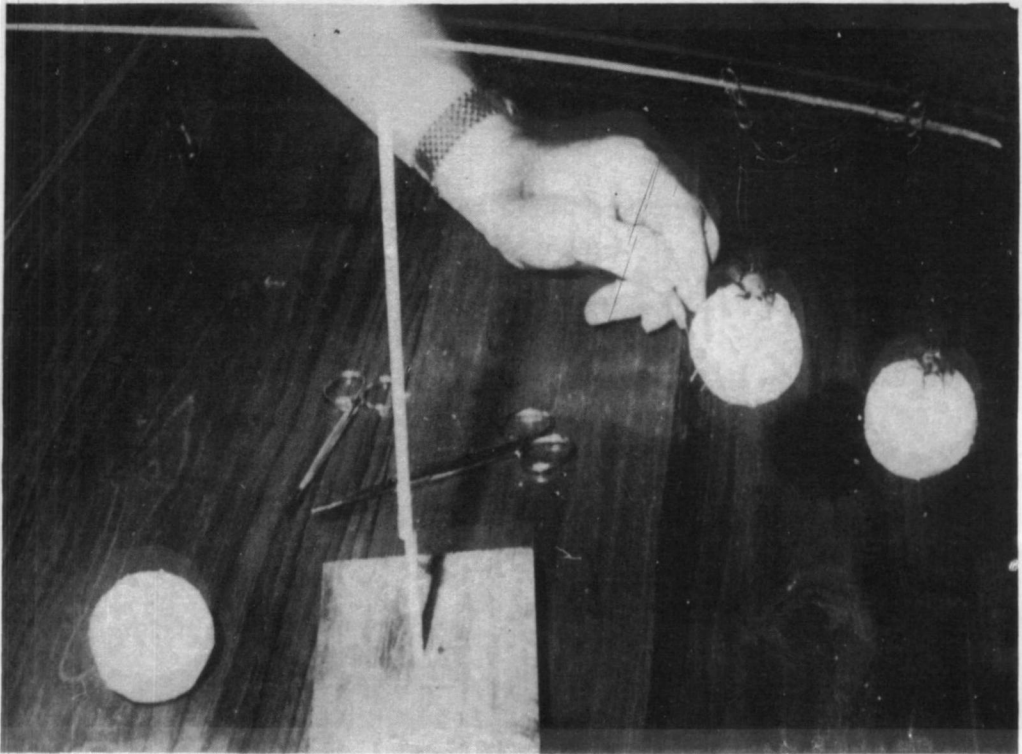

Fig. 1. Flight carrousel for tethered flight of red palm weevils, with suspended weevils "sitting on" styrofoam balls

sensitive crystal and the lower part of the photomultiplier. The iron shield was then covered with a lead sheet moulded into the shape of a funnel. The funnel had a small opening. With this arrangement accurate detection of labelled weevils was possible.

Range of detection of radiolabelled weevils.

The radiolabelled weevils were enclosed individually in small plastic bottles and the distance upto which they could be located with a portable polyradiameter was measured. The bottle with the labelled weevil was placed on the ground just behind the base of a palm so that the weevil was shielded by the trunk of the palm. The activity at various distances was determined from the opposite side of the palm. The weevils were labelled with different lengths of ^{192}Ir wire. Results are given in Table 1.

Table 1. Polyradiameter readings (Impulsions/sec X 1000) from red palm weevils labelled with four different lengths of radioactive Iridium, ^{192}Ir wire.

Length of Iridium wire	Distance of Weevil from Ployradiameter			
	1m	9m	13.5 m	18 m
L 1	2000	1300	1000	900
L 2	2200	1400	900	800
L 3	2800	1300	900	800
L 4	3640	1690	1170	1040

At a distance of 18 m, the initial activity obtained at 1 m was reduced to approximately 30–40 %. It is therefore evident that labelled weevils could be detected from a considerably long distance.

Half-thickness of coconut wood

Under laboratory conditions, the weakening of the emitted gamma-radiation of ^{192}Ir and ^{131}I passing through coconut wood was estimated. When gamma radiation passes through matter, it undergoes absorption by interacting with atoms of the absorbing material due to three effects viz. photoelectric effect, Compton effect and pair production (Chase and Rabinowitz, 1968). The result is a decrease in the intensity of the radiation with the distance traversed through the absorbing material. The half-thickness which is defined as the thickness of an absorber which decreases the intensity of a beam of gamma rays traversing through the absorbing material, to one half of its initial value, could be estimated experimentally. The initial intensity I_0 , after passing through an absorber of half-thickness is reduced to the intensity of $\frac{I_0}{2}$. Using a simple measuring arrangement (Fig. 2) and plotting the measured intensity ($\ln I$), against the thickness of the absorbing material, the half-thickness could be estimated graphically (Fig. 3).

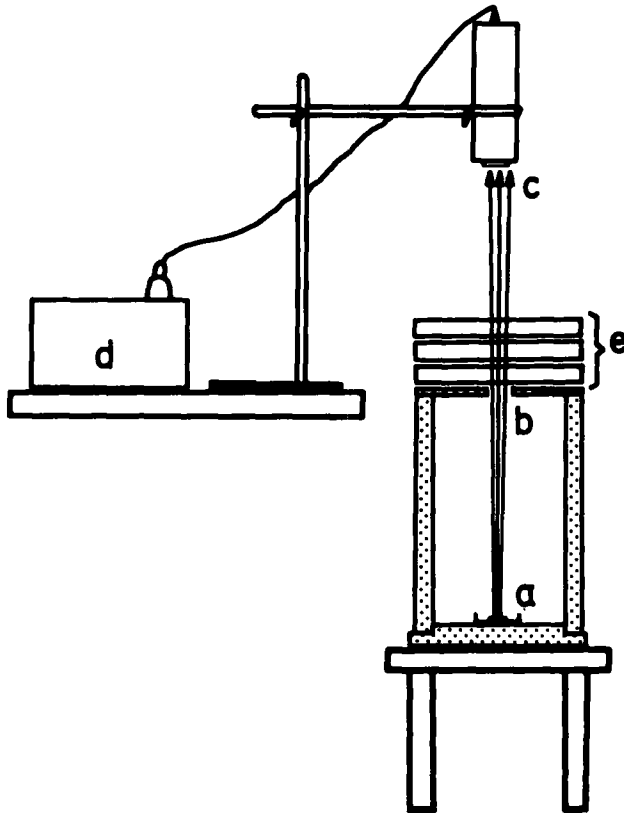

Fig. 2. Arrangement for the measurement of half-thickness of coconut timber.

- a. The radioisotope at the centre, on the bottom of a lead chamber.
 - b. A central hole in the lead cover, through which a narrow beam of radiation passes through.
 - c. Al-shielded end of the Gamma Scintillator Probe.
 - d. Analogue indicator of the Polyradiometer.
- Discs of coconut timber.

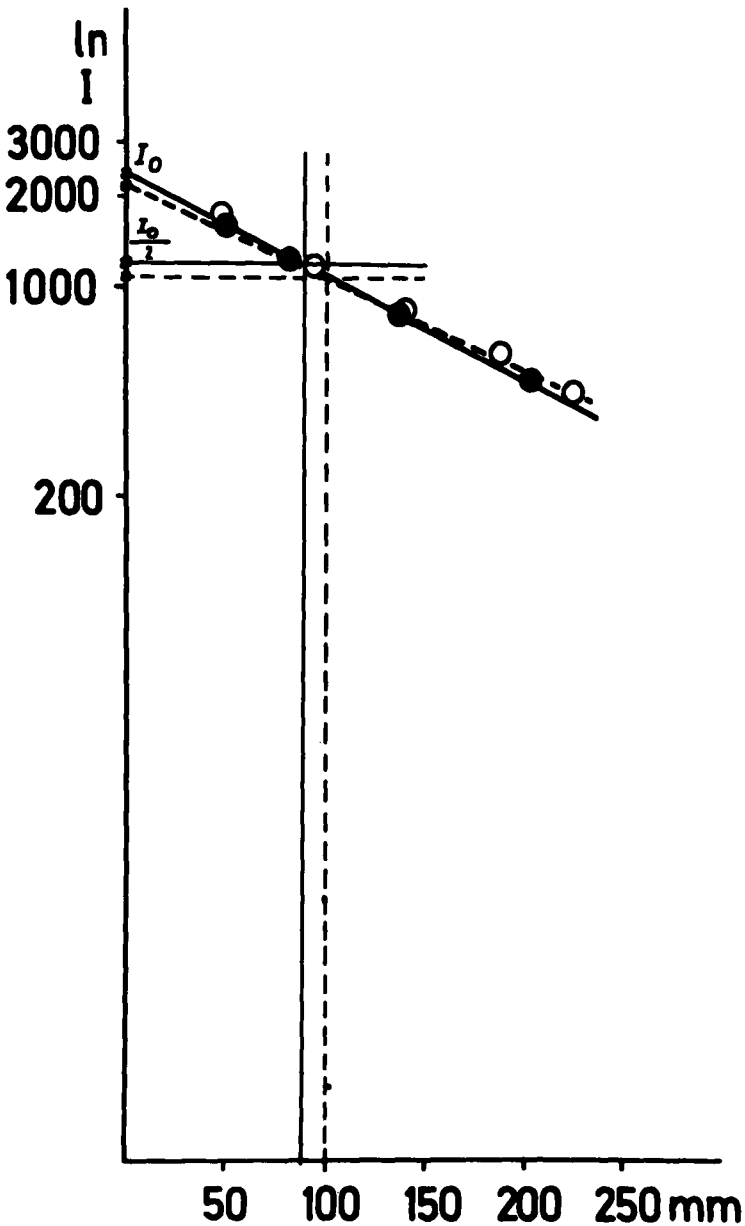

Fig. 3. Graphical determination of the half-thickness of coconut timber.

In the present study, the half-thickness of freshly cut and air dry coconut timber were worked out by using discs of different thickness. After measuring the initial intensity, I_0 , different layers of coconut trunks were brought into the beam, as illustrated in Fig. 2. The intensity decreased with increasing thickness of the absorbing material.

When $\log \ln I$ was plotted against the thickness, a straight line was obtained. By drawing a perpendicular line to meet the horizontal linear scale from the point where the straight line cuts $\frac{I_0}{2}$ the half thickness was obtained. It could be seen from Fig. 3 that the half-thickness for ^{192}Ir , of fresh coconut timber is 88 mm, and of air dried timber is 100 mm, Similar measurements were made using, radioiodine ^{131}I , and the data is presented in Table 2.

Table 2. Half-thickness of fresh and air-dried coconut timber for the radiation emitted by ^{192}Ir and ^{131}I .

Material	Half-thickness in mm	
	^{192}Ir	^{131}I
Fresh timber	88	870
Air-dried timber	100	1060

DISCUSSION

Radioisotopes would be useful in studies on the biology and behaviour of the red palm weevil. The radioisotopes used in the studies were γ emitting, Iodine, ^{131}I as Sodium iodide and Iridium, ^{192}Ir as Platinum clad wire. To prevent surface corrosion of the tracer by the haemolymph which would lead to radioactive excretion and possibly environmental contamination, the wire coated with Platinum was used. The γ rays are capable of penetrating through matter and hence useful in detecting radiolabelled weevils living inside the palm trunk.

The half-thickness of fresh coconut timber for ^{131}I was 870 mm whereas for ^{192}Ir , it was 88mm. This indicates that the range of detectability of labelled weevils is larger for ^{131}I than for ^{192}Ir . However, ^{192}Ir was used in labelling the weevils as the physical half-life of ^{131}I is 8.05 days whereas for ^{192}Ir it is 74 days. Also ^{192}Ir as wire could be cut into small pieces for insertion into the body of the insect.

As there was a possibility of injury, on account of the insertion of the wire into the flight muscles the fitness of labelled weevils for normal movement and flight was checked under controlled conditions. It was shown that the labelled weevils could fly as well as the unlabelled weevils.

Location of radiolabelled weevils, among unlabelled weevils would be essential in carrying out radioecological experiments. However with the available Gamma-probes, this was not possible on account of their design because, these probes were sensitive to γ -radiation reaching it from various directions. This problem was overcome by modifying the probe using an iron shield and a lead sheet cover with a narrow opening.

Further studies with labelled weevils in the field revealed that it was possible to detect labelled weevils at considerably long distances because at a distance of 18 m, the initial activity, obtained at 1 m was reduced to approximately 30-40 %.

ACKNOWLEDGEMENTS

We are grateful to the International Atomic Energy Agency and to Dr. Granville Dharmawardena, Chairman, Atomic Energy Authority of Sri Lanka for their support. Special thanks are due to Dr. D.T. Wettasinghe, Director, of the Coconut Research Institute for providing facilities for work at the institute, and for assistance with the preparation of the manuscript.

REFERENCES

- Chase, G. D. & Rabinowitz, R. L., (1968) *Principles of Radioisotope Methodology*, 633 pp. 3rd ed., Burgess Publishing Co., Minneapolis, Minn. 55415.
- Kloft, W.J. (1977). In "Laboratory Training Manual on the use of Isotopes and Radiation in Entomology". 2nd edn., 141–220 International Atomic Energy Agency, Vienna.
- Kloft, W.J. (1984). Chapter 2: Entomology, in *Isotopes and Radiation in Agricultural Sciences* (M.F.L. Annunciata & I.O. Legg, eds.) Vol. 2, 51–103. Academic Press Inc, London – Orlando, FL.
- Kloft, W.J. & Hoelldobler, B. (1964). Untersuchungen zur forstlichen Bedeutung der holzzerstörenden Robameisen unter Verwendung der Tracermethode Anz. f. Schaedlingskunde 37, 163 – 169.
- Kloft, W.J. Hoelldobler, B & Haisch, A (1965). Traceruntersuchungen zur Abgrenzung von Nestarealen holzzerstörender Robameisen (*Camponotus ligniperda* Latr. und *C. herculeanus* L) in lebenden Bäumen. Entomologica exp. et. appl. 8, 20–26.
- Kloft, W.J. Koerner, J & Wolfram, E. (1986). Studies on the use of radioisotopes for the control of the red palm weevil, *Rhynchophorus ferrugineus* F. by the Sterile Insect Technique:–
2. A technique for tagging insects with precise lengths of radioactive Iridium, ^{192}Ir wire. Cocos 4,.....
- Kurian, C. (1979). *Rhynchophorus ferrugineus* F. in: *Krankheiten, Schaedlinge und Unkraeuter im tropischen Pflanzenbau* (J. Kranz, H Schmutterer & W. Koch, eds,) 442–445. Verlag Paul Parey, Berlin & Hamburg.
- Pillai, M. D. (1984). Bibliography on Red Palm Weevil (*Rhynchophorus ferrugineus* FABR.) a pest of coconut (*Cocos nucifera* Linn). Indian Coconut Journal, February 1984, 5–8.
- Rahalkar, G. W., Mistry, K. B., Harwalker, M. R., Bharathan, K. G. and Gopal – Ayengar, A. R. (1971). Labelling adults of Red Palm Weevil (*Rhynchophorus ferrugineus*) with Cerium for detection by neutron activation. Ecology 52, 186 – 188.
- Rahalkar, G. W., Harwalker, M. R. Ranavare, H. D. and Kurian, C., Abraham, V. A. and Abdulla Koya K. M. (1977). Preliminary field studies on the control of the Red Palm Weevil, *Rhynchophorus ferrugineus* Oliv, using radiosterilized males. J. Nuclear Agric, biol. 6. 65–68.
- Rahalkar, G. W., Harwalker, M. R. Ranavare, H. D. Shantaram, K. and Gopal Ayengar, A. R. (1973). Laboratory studies on radiation sterilization of the Red Palm Weevil (*Rhynchophorus ferrugineus* Oliv) males. Proc. National Symposium on Plantation Crops, J. Plant. Crops 1 (Suppl.) 141–146.

Rahalkar, G. W. Shantaram, K., Harwalkar, M. R. & Ranavare, H. D. (1982). Mating competitiveness and effective life of the radiation sterilized male Red Palm Weevil, *Rhynchophorus ferrugineus* Oliv In: "Sterile Insect Technique and Radiation in Insect Control" 395-400, International Atomic Energy Agency Vienna.