



CHALMERS
UNIVERSITY OF TECHNOLOGY

Review - Reference Electrodes in Li-Ion and Next Generation Batteries: Correct Potential Assessment, Applications and Practices

Downloaded from: <https://research.chalmers.se>, 2022-07-02 09:25 UTC

Citation for the original published paper (version of record):

Cengiz, E., Rizell, J., Sadd, M. et al (2021). Review - Reference Electrodes in Li-Ion and Next Generation Batteries: Correct Potential Assessment, Applications and Practices. *Journal of the Electrochemical Society*, 168(12).
<http://dx.doi.org/10.1149/1945-7111/ac429b>

N.B. When citing this work, cite the original published paper.

OPEN ACCESS

Review—Reference Electrodes in Li-Ion and Next Generation Batteries: Correct Potential Assessment, Applications and Practices

To cite this article: Elif Ceylan Cengiz *et al* 2021 *J. Electrochem. Soc.* **168** 120539

View the [article online](#) for updates and enhancements.

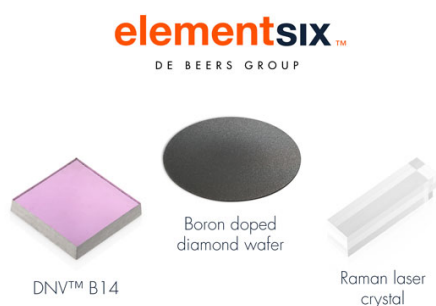

Element Six is a world leader in the development and production of synthetic diamond solutions

Since 1959, our focus has been on engineering the properties of synthetic diamond to unlock innovative applications, such as thermal management, water treatment, optics, quantum and sensing. Our patented technology places us at the forefront of synthetic diamond innovation, enabling us to deliver competitive advantage to our customers through diamond-enabled solutions.

Find out more and contact the team at:
ustechnologies@e6.com





Review—Reference Electrodes in Li-Ion and Next Generation Batteries: Correct Potential Assessment, Applications and Practices

Elif Ceylan Cengiz,[✉] Josef Rizell,[✉] Matthew Sadd, Aleksandar Matic, and Nataliaia Mozhzhukhina[✉]

Department of Physics, Chalmers University of Technology, SE 412 96, Göteborg, Sweden

This review provides an accessible analysis of the processes on reference electrodes and their applications in Li-ion and next generation batteries research. It covers fundamentals and definitions as well as specific practical applications and is intended to be comprehensible for researchers in the battery field with diverse backgrounds. It covers fundamental concepts, such as two- and three-electrodes configurations, as well as more complex quasi- or pseudo- reference electrodes. The electrode potential and its dependence on the concentration of species and nature of solvents are explained in detail and supported by relevant examples. The solvent, in particular the cation solvation energy, contribution to the electrode potential is important and a largely unknown issue in most of the battery research. This effect can be as high as half a volt for the Li/Li⁺ couple and we provide concrete examples of the battery systems where this effect must be taken into account. With this review, we aim to provide guidelines for the use and assessment of reference electrodes in the Li-ion and next generation batteries research that are comprehensive and accessible to an audience with a diverse scientific background.

© 2021 The Author(s). Published on behalf of The Electrochemical Society by IOP Publishing Limited. This is an open access article distributed under the terms of the Creative Commons Attribution 4.0 License (CC BY, <http://creativecommons.org/licenses/by/4.0/>), which permits unrestricted reuse of the work in any medium, provided the original work is properly cited. [DOI: 10.1149/1945-7111/ac429b]



Manuscript submitted October 27, 2021; revised manuscript received December 1, 2021. Published December 22, 2021. *This paper is part of the JES Focus Issue on Women in Electrochemistry.*

We are witnessing an enormous increase in battery research and development at both the academic and industrial levels. This is largely due to the need for improvement of existing batteries technologies in terms of energy density, durability and safety, and the development of new and emerging battery technologies. To achieve this goal, it is essential that scientists from the diverse backgrounds contribute to the rapidly evolving battery research field and currently there are a number of interdisciplinary and inter-institutional battery projects with researchers from chemistry, physics, materials science, computational and data science, just to name a few, working together to accelerate the battery innovation and improvement process at all levels starting from fundamental materials research to the battery pack design.^{1–4} Since batteries are electrochemical systems, basic electrochemical knowledge is essential in all parts along the value chain. One of the critical, yet sometimes overlooked, issues relating to fundamental electrochemistry in battery research is the correct evaluation of electrode potentials with respect to a reference/counter electrode.

While the three-electrode configuration is the “gold standard” of the classic electrochemistry, the typical battery only consists of two electrodes, the anode and cathode. For this reason, as well as for the sake of simplified experimental set-up, the vast majority of battery research is performed in a two-electrode configuration, often using the “half-cell” concept. For a Li-ion battery this implies that the electrode material of interest is used as a working electrode, while metallic lithium is used as both the counter and reference electrode simultaneously. Although lithium metal is a non-ideal reference electrode, this simplified configuration has worked reasonably well. However, the expansion of research interests into the post Li-ion era and the use of other alkali and alkali earth metals as active species, has shown that utilizing a metal counter-reference electrode is not always an acceptable configuration for those chemistries.⁵

We will cover the requirements for the reference electrode from both a fundamental electrochemistry and a battery research point of view, providing an overview of the available reference electrodes for Li-ion and next generation battery technologies. Special attention will be paid to the influence of solvent (and the solvation energy)

and salt concentration on the potentials of alkali metal electrodes. We will also clarify for which battery chemistry, and specific experimental set ups, this solvent-dependent voltage variation must be taken into account, and when it could be neglected. With this as a guide, battery researchers with diverse backgrounds, can perform more reliable and comparable measurements.

Why and When is It Necessary to use Three Electrodes Configuration?

Conventional cells used in battery research are composed of negative and positive electrodes which are in a two-electrode configuration. These types of cells are named as “full cell setup” and their voltage depends on the difference between the potentials of the two electrodes.⁶ When a given material is evaluated as electrode it is instead typically coupled to a metal electrode in what is termed as “half-cell setup.”⁶ In most battery related publications half-cells or a two-electrode configuration are used, i.e. the cell consists of a working (WE) and a counter electrode (CE). In this configuration, the CE acts as both a current source by completing the circuit and a probe for measuring the cell potential fulfilling the role of a reference electrode (RE) (Fig. 1a). To monitor and control the potential of WE, no or a very small current should flow through the reference electrode to prevent the effect of polarization on the measured voltage,⁶ which is not possible in galvanostatic cycling since relatively high current is passed through the CE/RE which results in polarization and change of its potential. Thus, only the overall cell voltage, and not that of the individual electrodes, can be tracked in a two-electrode setup.⁶ To prevent fluctuations in potential and to control the potential of the WE precisely, an additional (third) electrode should be added. In this configuration, which is known as a three-electrode cell, the third electrode serves as the RE, thus the CE and RE are separated. As can be seen from Fig. 1b, in the three-electrode cell, the current only flows between WE and CE, while the potential of the RE is not perturbed by the current being drawn from the cell, which provides excellent control over the potential of WE⁷ and reliable and accurate results can be obtained.

In the commonly used two-electrode cell, the CE also works as the RE, therefore the potential of the CE/RE is not constant. This voltage variation depends on the nature of the electrode, and in certain cases (for example for lithium and low currents) can be neglected. This issue was addressed by Iermakova et al.,⁸ who have

[✉]These authors contributed equally to this work.

[✉]E-mail: nataliaa.mozhzhukhina@chalmers.se

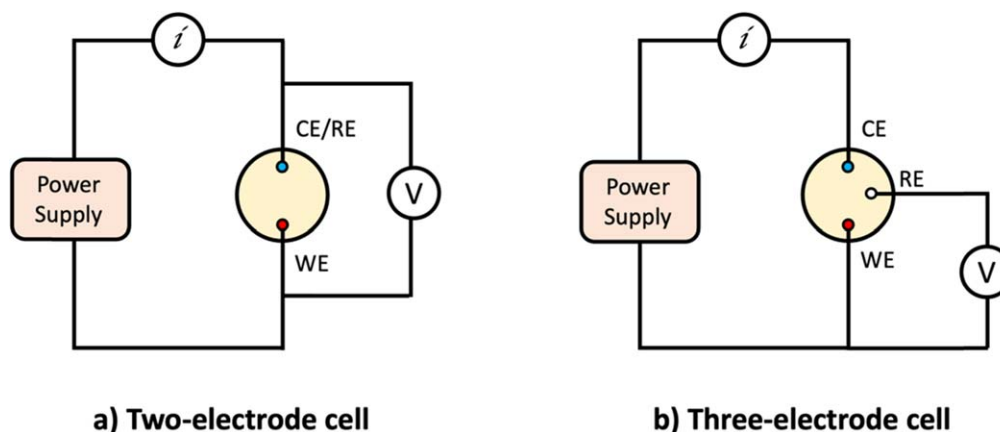

Figure 1. Schematic representation of (a) two-electrode and (b) three-electrode cell configurations.

demonstrated different overpotentials observed for distinct metal anodes, Li and Na, as well as different electrolyte formulations, cycled in symmetric (two-electrode) cells. As can be seen from Fig. 2, the cell containing a Li anode was characterized by a relatively low overpotential. However, the cells using a Na anode displayed a higher overpotential compared to the Li metal containing cell, independent of the electrolyte used. Generally, the overpotential arises from several phenomena: (i) mass transport of metal cations (M^+) in electrolyte which depends on viscosity and ionic conductivity of electrolyte, (ii) cation desolvation energy at the solid electrolyte Interphase (SEI)/electrolyte, (iii) cation transport through the SEI (if any), and iv) metal nucleation barrier which is dependent on the nature of the substrate and cation. In the case of sodium, it was concluded that a high SEI resistivity was the main cause of increased cell overpotential. Lithium metal on the other hand exhibits a small, stable and reproducible overpotential when currents up to around 1 mA cm^{-2} are applied.⁹ Other metal electrodes like Na, K, Mg or Ca, used in post-lithium batteries, have large and unstable and/or irreproducible the overpotentials. In this case, a three-electrode cell should be used to avoid the polarization of the reference electrode. We will return to the suitable reference electrode materials later in this review.

In a three-electrode cell configuration, the circuit is modified so that the reference electrode is not affected by the current applied to the cell. Therefore, the overpotential caused by the applied current, or kinetically caused overpotential, can be prevented. However, even if no current is passed through the reference electrode, its potential may still vary due to the nature of the given reference electrode and its environment, due to thermodynamic considerations. Therefore, one should put emphasis not only on the cell design, but also the selection and correct voltage assessment of the reference electrode to provide reliable results. This phenomenon will be described in detail in the following sections.

Standard Electrode Potential, Nernst Equation and Quasi- or Pseudo-Reference Electrodes

Since it is only possible to measure the potential difference between two electrodes and not an absolute electrode value, an arbitrary standard for zero had to be chosen, that is the Standard Hydrogen Electrode (SHE). The SHE consists of a platinum electrode submerged in a 1 M solution of H^+ in water at 25°C with a 1 atm of H_2 bubbled through the solution.¹⁰ These conditions are named as “Standard Conditions” and the standard potential for a redox reaction is defined as the potential of a cell measured under these conditions vs SHE. Examples of Standard Electrode Potentials (E°) of selected redox couples at standard conditions vs SHE are shown in Table I.

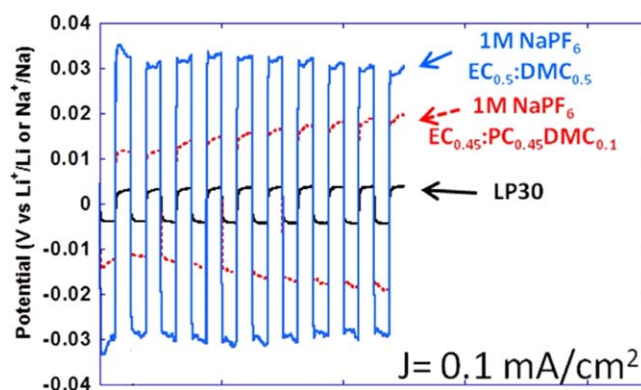

Figure 2. Charge/discharge curves of symmetric Li/Li and Na/Na cells cycled at 25°C in LP30 (1 M LiPF_6 in $\text{EC}_{0.5}\text{DMC}_{0.5}$), 1 M NaPF_6 in $\text{EC}_{0.5}\text{DMC}_{0.5}$ or 1 M NaPF_6 in $\text{EC}_{0.45}\text{PC}_{0.45}\text{DMC}_{0.1}$ at 0.1 mA cm^{-2} . Reproduced from.⁸

Most experiments are not carried out under standard conditions. To determine the electrode potential in this case, the Nernst equation should be used. Consider a general reaction occurring at an electrode:



The potential, E , of the electrode where this reaction occurs will be related to the change in Gibbs Free Energy, ΔG , between reactants and products:

$$\Delta G = -nFE \quad [2]$$

where, n is the number of electrons and F is the Faraday constant. Although not explicit, Eq. 2 depends on the conditions the reaction is carried out under (concentration, temperature, pressure). Under standard conditions, the convention is to write this equation as:

$$\Delta G^\circ = -nFE^\circ \quad [3]$$

Part of the effect of the reaction conditions on Gibbs free energy can be more explicitly accounted for using the following equation from classical thermodynamics:

$$\Delta G = \Delta G^\circ + RT \ln Q \quad [4]$$

where R , T and Q are the gas constant, the temperature and the reaction quotient, respectively. To find an equation that describes the potential instead of Gibbs free energy, the expressions from Eqs. 2 and 3 can be substituted into Eq. 4. After rearranging the terms, the

Table I. Standard Electrode Potentials vs SHE of selected redox couples in aqueous solutions and in propylene carbonate (PC)¹¹ at 25 °C.

Half Cell	Solution	Electrode Reduction Reaction	Potential, E° (V)
Ag AgCl Cl ⁻	in water	AgCl + e ⁻ → Ag + Cl ⁻	+0.22
Mn Mn ²⁺	in water	Mn ²⁺ + 2e ⁻ → Mn	-1.18
Mg Mg ²⁺	in water	Mg ²⁺ + 2e ⁻ → Mg	-2.36
Na Na ⁺	in water	Na ⁺ + e ⁻ → Na	-2.71
K K ⁺	in water	K ⁺ + e ⁻ → K	-2.93
Li Li ⁺	in water	Li ⁺ + e ⁻ → Li	-3.05
Na Na ⁺	in PC	Na ⁺ + e ⁻ → Na	-2.56
K K ⁺	in PC	K ⁺ + e ⁻ → K	-2.88
Li Li ⁺	in PC	Li ⁺ + e ⁻ → Li	-2.79

Nernst equation is obtained:

$$E = E^{\circ} - \frac{RT}{nF} \ln Q \quad [5]$$

which relates the electrode potential to the concentration of reactants and products through the reaction quotient, Q . For the general reaction (1) the reaction quotient can be written as:

$$Q = \frac{[A]^a [B]^b}{[C]^c [D]^d} \quad [6]$$

The exponents a , b , c and d are the coefficients from the reaction (Eq. 1), while the brackets denote the activities of the reactants or products. However, as long as the reactants/products are diluted, it is a valid approximation to use the concentration of each species instead of the activity.

To exemplify the use of this equation, we apply it to an Ag/AgCl reference electrode. This is the most common reference in aqueous electrochemistry due to its ease of assembly, cost, non-toxicity, and the stability of its potential. It consists of a silver wire coated with solid, insoluble AgCl, which is immersed in a chloride containing aqueous solution (generally 3 M KCl).¹² The net chemical reaction in the electrode in this case will be:

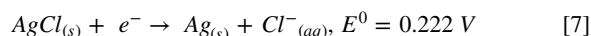

Consequently, the Nernst equation for the Ag/AgCl electrode can be written as:

$$E = E^{\circ} + \frac{RT}{F} \ln \left(\frac{[AgCl]}{[Ag] \cdot [Cl^{-}]} \right) \quad [8]$$

Since the activities of pure solids are equal to unity, the equation can be simplified to:

$$E = E^{\circ} - \frac{RT}{F} \ln [Cl^{-}] \quad [9]$$

This expression illustrates that the Ag/AgCl electrode potential is dependent on the activity of Cl⁻ ions, even though Cl⁻ ions are not part of the redox reaction. For a 0.01 M Cl⁻ solution, Eq. 9 gives an electrode potential of 0.34 V (vs SHE) for the Ag/AgCl electrode. Increasing the Cl⁻ ion concentration further will decrease the potential, and for a 1 M Cl⁻ solution, it will be 0.222 V. This showcases that the activities of all species that participate in the overall chemical reaction influence the electrode potential, and not only the ones which are redox active.

If the AgCl coated Ag wire is immersed in a solution without Cl⁻ anions instead, it is not possible to use the Nernst equation to determine its potential. In this case it becomes what is known as “quasi-” or “pseudo-” reference electrode.¹³ Such electrodes do not have a constant and well-defined potential, instead they possess a

potential which can change over time and thus, they do not strictly fulfill the requirements for a reference electrode. To be more precise, quasi-reference electrodes display non-Nernstian behavior, *i.e.*, their potential cannot be defined by Nernst equation due to the lack of a thermodynamic equilibrium. For instance, it is common that quasi-reference electrodes are metallic wires, often Pt or Ag, placed in the same solution as the working electrode. In this case, the potential of quasi-reference electrodes is based on the equilibrium between metal and surface species, but there is no common component (anion or cation) between these two. Thus, a thermodynamic equilibrium cannot be established and consequently, the quasi-reference electrode potential is not well-defined.¹² Instead, the potential of quasi-reference electrodes depends on (i) reactions with impurities, (ii) solvation of oxides, which are present on metal surfaces in solution, (iii) polarization, (iv) its recent usage history.¹³ We should emphasize that quasi-reference electrodes can still be used successfully for several applications. They are often easy to implement and can work in systems where it would be difficult to use a conventional reference electrode.⁵ However, it is essential to confirm that the potential of the quasi-reference electrode is stable over time in the particular system and to calibrate its potential using a reliable reference during the experiments. For example, the ferrocene/ferrocenium couple could be used as a reliable external Ref. 14.

Reference Electrode Potential Dependence on The Electrolyte: Nature of Solvent and Salt Concentration

In the previous section, the relation between the potential and the specific redox reaction as well as the concentration of species in aqueous solution was discussed. However, additional considerations must be taken into account when estimating the potential of alkali metal reference electrodes in distinct electrolytes. In this section the effect of the solvent on the standard electrode potential will be discussed. We will additionally cover the special case of potential estimation for the highly concentrated electrolytes.¹⁵

Effect of the solvation energy.—Typically, the standard potential for the Li/Li⁺ couple is referred as -3.05 V vs SHE (Table I). It is important to remember that this potential was determined using an alloy of lithium and mercury, called amalgam, being measured in aqueous solution,¹⁶ according to the equation:

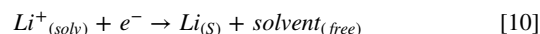

However, the change of solvent from water to organic electrolytes influences the standard potential of Li/Li⁺ couple. This effect has been illustrated by Mozhzhukhina and Calvo, by measuring the potential of a metallic lithium wire immersed in different solvents with respect to ferrocene/ferrocenium couple that is known to be solvent independent,¹⁷ Figure 3a. A similar effect has been observed by Schneider et al., who have measured the potential difference between two lithium metal electrodes immersed in distinct electrolytes (Fig. 3b).¹⁸ Notably, the potential of Li/Li⁺ couple can vary as

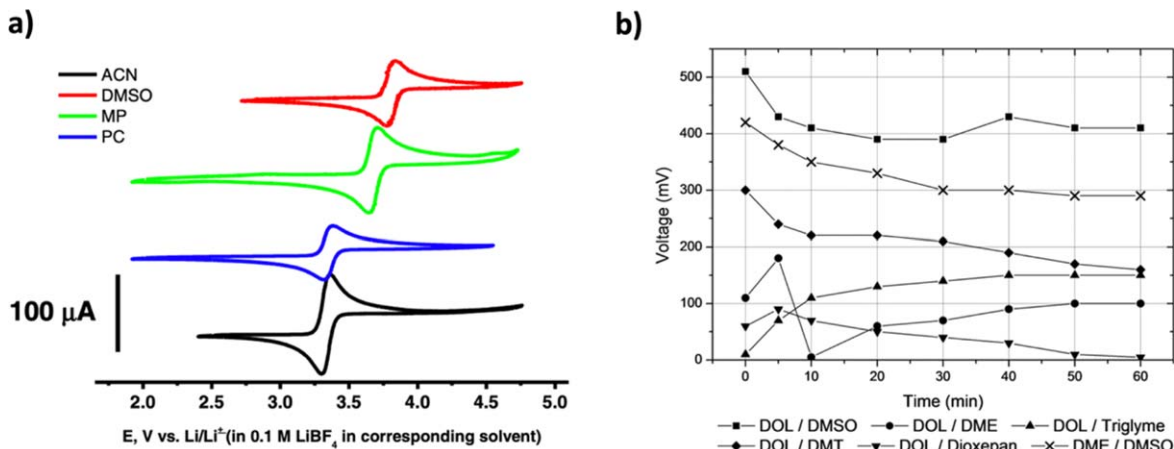
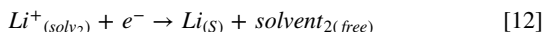
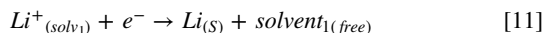

Figure 3. Effect of solvent on the potential of Li/Li⁺ couple: (a) potentials of ferrocene/ferrocenium couple measured vs Li/Li⁺ in different solvents, reproduced from,¹⁷ (b) voltage between two lithium wires immersed in some different electrolytes measured vs time, reproduced from.¹⁸

much as 500 mV between solvents, and the voltage can change with time, due to the formation of surface layers on the lithium metal.

This phenomenon can be rationalised considering the solvation energy of Li⁺ in different solvents. To derive the relation between the electrode potential and Gibbs free energy of solvation, we will consider the reaction 10 in two different solvents, solvent 1 and solvent 2:



where $Li^+_{(solv_1)}$ and $Li^+_{(solv_2)}$ denote Li ions solvated by solvent 1 and 2, respectively. In these equations, the solvation numbers are neglected for the sake of simplicity, since they would not have any effect on the final result. The change in Gibbs free energy for the two reactions can be written as:

$$\Delta G_1^\circ = \Delta G^\circ(Li_{(s)}) + \Delta G^\circ(solvent_{1(free)}) - \Delta G^\circ(Li^+_{(solv_1)}) \quad [13]$$

$$\Delta G_2^\circ = \Delta G^\circ(Li_{(s)}) + \Delta G^\circ(solvent_{2(free)}) - \Delta G^\circ(Li^+_{(solv_2)}) \quad [14]$$

Considering that $E^\circ = -\frac{\Delta G^\circ}{nF}$, the difference in the standard potential when Li is electrodeposited in different solvents (reactions 11 and 12) can be written as:

$$\Delta E^\circ = -\frac{\Delta G_1^\circ - \Delta G_2^\circ}{nF} \quad [15]$$

Substituting Eqs. 13 and 14 into this expression, the potential difference between two reactions will be:

$$\Delta E^\circ = -\left[\frac{\Delta G^\circ(solvent_{1(free)}) - \Delta G^\circ(Li^+_{(solv_1)})}{nF} - \frac{\Delta G^\circ(solvent_{2(free)}) - \Delta G^\circ(Li^+_{(solv_2)})}{nF} \right] \quad [16]$$

However the expression $\Delta G^\circ(solvent_{1(free)}) - \Delta G^\circ(Li^+_{(solv_1)})$ is essentially the Gibbs free energy of Li⁺ solvation by solvent 1, which we would write as $\Delta G^\circ solvation_1$. Similarly, $\Delta G^\circ(solvent_{2(free)}) - \Delta G^\circ(Li^+_{(solv_2)})$ is the Gibbs free energy of Li⁺ solvation by solvent 2, or $\Delta G^\circ solvation_2$. Therefore, the potential difference between the reactions in Eqs. 11 and 12 is directly proportional to the difference in the Gibbs free energy of Li⁺ solvation between solvent 1 and solvent 2:

$$\Delta E^\circ = -\frac{\Delta G^\circ solvation_1 - \Delta G^\circ solvation_2}{nF} \quad [17]$$

The solvation effect is particularly strong for the small Li⁺ ion, that is typically characterised by larger solvation shells and stronger dependence on the solvents. It should also be considered when comparing the potentials of Li/Li⁺ to Na/Na⁺ or K/K⁺ couples, since the $\Delta G^\circ(solv)$ difference for these cations would vary between different solvents. While the potential difference between Li/Li⁺ and Na/Na⁺ couples in water is 0.33 V, its value in propylene carbonate is only 0.23 V (Table 1). Additionally, while the Li/Li⁺ couple standard potential is the most negative of the three alkali metal couples in water, in the organic solvent propylene carbonate the K/K⁺ couple standard potential is the most negative, 90 mV lower than that of Li/Li⁺.

Effect of highly concentrated electrolytes.—To understand the effect of a highly concentrated electrolyte on the electrode potential the reaction 10 will be considered. The Nernst equation for this reaction can be written as

$$E = E^\circ - \frac{RT}{nF} \ln \left(\frac{[Li^+_{(solv)}]}{[Li_{(s)}][solvent_{(free)}]} \right) \quad [18]$$

Since the $Li_{(s)}$ and solvent are a pure solid and liquid, respectively, their activities are equal to unity and can therefore be removed from the equation:

$$E = E^\circ - \frac{RT}{nF} \ln ([Li^+_{(solv)}]) \quad [19]$$

However, this approximation is not valid for the case of highly concentrated electrolytes, since the amount of free solvent molecules is very low and their activity (concentration) can no longer be neglected. Instead, the following form of the Nernst equation should be used:

$$E = E^\circ - \frac{RT}{nF} \ln \left(\frac{[Li^+_{(solv)}]}{[solvent_{(free)}]} \right) \quad [20]$$

The effect of salt concentration has been demonstrated by Kottam et al., who compared experimental potentials measured in a variety of electrolytes from diluted to highly concentrated, with potential values calculated according to Eqs. 19 and 20, and have observed a deviance at concentrations of > 0.2 M of LiTFSI in DMSO,¹⁵ Fig. 4a. When the salt concentration is increased, there is an

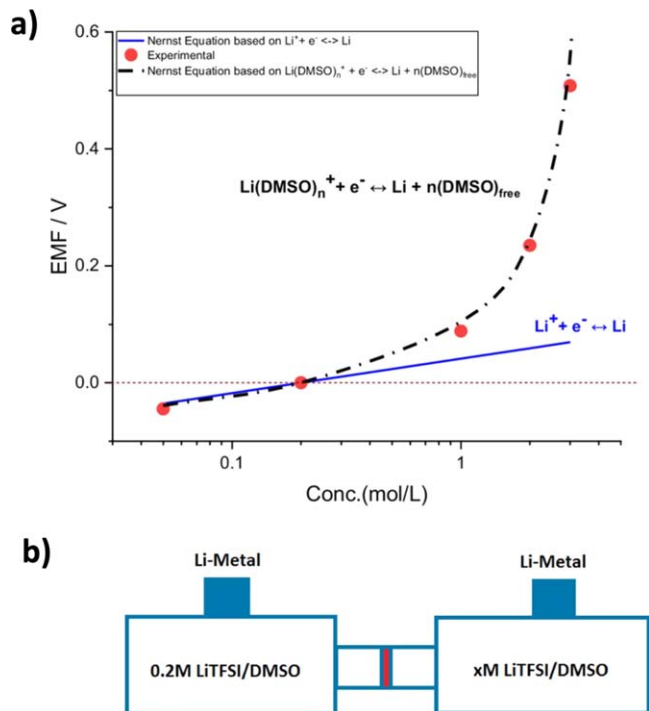

Figure 4. (a) Potential of Li/Li^+ couple as a function of electrolyte concentration (b) experimental concentration cell. Reproduced from.¹⁵

exponential dependence of the potential, which is correctly accounted for by including the activity of free solvent species into the Nernst equation.

Therefore the potential of Li/Li^+ couple will depend on the number of free molecules in the case of highly concentrated electrolytes.¹⁵ Even though solvent molecules undergo neither oxidation nor reduction, their activity still contributes to the electrode potential, analogous to the way the activity of Cl^- ions influences the Ag/AgCl electrode potential (as shown in the previous section). However, when dealing with concentration cells (Fig. 4b), there is also a possibility that the measured potential can be partly attributed to the junction potential formed at the interphase of two electrolytes with different concentrations, that also has to be accounted for, as has been highlighted by Degoulange et al. when evaluating potentials shifts in water-in-salt electrolytes.¹⁹

When Does the Electrolyte Dependent Alkali Metal Reference Electrode Potential Deviation Matter?

In the previous section we showed that the alkali metal reference electrodes are subject to a strong potential deviation depended on the choice of electrolyte. This potential deviation is calculated using the Eq. 17 which means that it is present at equilibrium conditions even without any current applied to the system. Therefore, it is observed using both two and three electrode configurations. However, this effect is cancelled out when both working and reference electrode include the same cation solvation/desolvation process, which is common in battery research. This can be illustrated by using a graphite lithium half-cell as an example. In this case the reaction at the lithium electrode is described by Eq. 10, while the following reaction takes place at the graphite electrode:

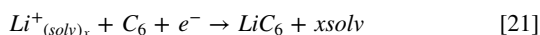

while the overall cell reaction is:



The $x\text{solv}$ and $\text{Li}^+_{(\text{solv})_x}$ terms cancel out in the overall cell reaction. Therefore, both the Gibbs free energy and the cell potential will be independent of the choice of electrolyte, i.e. they are not affected by either the solvent type or the salt concentration. However, in cases when the same ion solvation/desolvation process is not happening on both electrodes, the potential difference due to the nature of electrolyte must be taken into account. Below we provide several examples of such systems.

Redox mediators.—Redox-active molecules have gained popularity for their potential to improve the performance of Li-air (Li-oxygen), Li-S and redox-flow batteries.^{20,21} Redox mediators are molecules, polymers or ionic compounds that can be reversibly reduced and oxidized during electrochemical cycling. Depending on the battery chemistry they can serve as agents to improve the bulk conductivity, lower reaction overpotential, overcharge protection etc.^{20,21} In this cell configuration the reaction at the lithium electrode is described by Eq. 10, while the reaction involving redox mediator can be written as:



While the overall cell reaction is:

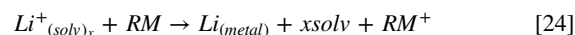

In this case the Gibbs free energy of Li-ion solvation is included in the overall reaction and would contribute to the ΔE between two analogous reactions happening in two different electrolytes. This effect was demonstrated by Yao et al.,²² who reported a significant change in the redox mediator potential and the charging voltage of Li- O_2 cells due to Li^+ solvation energy in different organic solvents and ionic liquid based electrolytes.

Solvent decomposition.—The electrolyte stability window is a very important parameter to consider in any electrochemical system,²³ and batteries in particular. Very often in the literature the electrolyte stability is reported vs Li/Li^+ for different electrolytes. However, the variation of $\text{M}/\text{M}^{\text{n+}}$ ($\text{M} = \text{Li}, \text{Na}, \text{K}, \text{Mg}, \text{Ca}$ etc.) couples in different solvents makes this comparison ambiguous. In this case the reaction at the lithium electrode is described by Eq. 10, while the solvent decomposition reaction is the following:



while the overall cell reaction is:

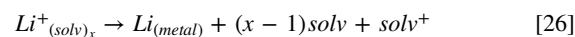

which again includes the term for the solvent in the overall reaction, and consequently leads to the error in order of hundreds of mV in the measurement of electrolyte electrochemical stability window.

Solvated ion intercalation.—In the example above we have featured an example of naked (unsolvated) lithium-ion intercalation into graphite. However, in some solvents, a solvated ion intercalation into graphite takes place, which is also known as solvent co-intercalation.²⁴ This phenomenon is particularly interesting for sodium-ion batteries since unsolvated Na^+ does not intercalate into graphite under normal conditions.²⁵ Interestingly, the potential difference between naked ion and solvated ion intercalation can be as high as 0.7 V when measured vs a Na/Na^+ Refs. 26–28. The large potential difference mainly arises from the Gibbs free energy of solvation, according to:

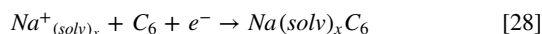
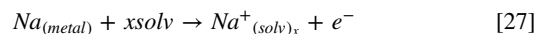

with the overall reaction written as:



For the case of naked ion intercalation the overall reaction is (as discussed above):

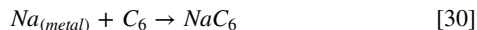

The voltage difference between those two reactions partly arises from the difference in the standard potential of naked vs solvated ion intercalation into graphite, however to a larger extent it is the result of the contribution of the Gibbs free energy of ion solvation.

Dual batteries.—The concept of dual batteries involves two electrodes of the same nature (graphite), each allowing intercalation of both the cation and the anion.^{29,30} The anode reaction can be written as:

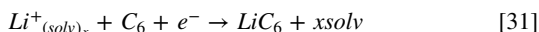

while for the cathode anion intercalation takes place. Typically, large anions with a delocalized charge are used in battery research PF_6^- , $TFSI^-$, FSI^- , BF_4^- etc., that are not readily solvated:

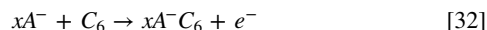

giving an overall reaction of:

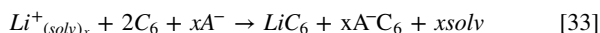

Once again, since the Li ion solvation Gibbs free energy contributes to the overall reaction, the voltage would be a subject to a great variation between different electrolytes.

Li-O₂ and Li-S systems.—In these battery concepts, lithium metal is typically used as an anode, while oxygen or sulfur reduction takes place on the cathode to form Li_2O_2 or Li_2S as final discharge products.³¹ Eventually, since both the anode and cathode would include the same ion desolvation process, its effect on the overall voltage can be neglected. However, this effect can still be significant during the intermediate reactions steps, as illustrated by Schneider et al., Fig. 5.¹⁸ As they describe in their work, the high voltage plateau (2.7–2.8 V) is higher when using dimethyl sulfoxide (DMSO) as solvent compared to a mixture of DMSO and dimethyl ether (DME), since $\Delta G_{(solv)}Li^+$ contributes to a higher potential difference when lithium is dissolved and solvated Li^+ remains in the solution. In this case anode reaction is described by Eq. 10, while the following reaction occurs at the cathode:

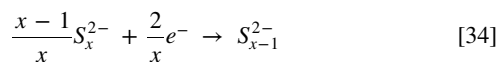

while the low voltage plateau (≈ 2 V) is lower for DMSO since $\Delta G_{(solv)}Li^+$ contributes to lower potential difference when Li^+ ions desolvate and Li_2S precipitates.

In all the previous examples the Gibbs free energy of metal ion solvation is included in the overall reaction and contributes to ΔE . Therefore, the solvent effect must be taken into consideration. A careful consideration of the studied system is important in order to have a correct potential interpretation and to draw the right conclusions. Writing down the possible electrochemical reactions occurring on the electrodes is a good practice in order understand which effects might be at play and to avoid any misinterpretations.

Overview of the Reference Electrodes Used in Li and Post Li Battery Research

Reliable results in a three-electrode cell are dependent on the selection of an appropriate reference electrode. Ideally, a reference electrode should possess the following properties^{12,32}:

- i) It should be chemically and electrochemically stable.
- ii) It should be non-polarizable, so that its potential does not change with the application of small currents.
- iii) Its potential should be stable and not change over time.
- iv) It should have a well-defined and reversible redox reaction that defines the electrode potential.

In practice, all these requirements are rarely fulfilled, necessitating a compromise in the selection of a suitable reference electrode for the application at hand. Since each of these properties depend on the system the RE is being used in, a wide range of reference electrodes suitable for different systems and measurements have been proposed in literature.^{5,7} In this section we will discuss some common reference electrodes and describe their strengths and weaknesses.

When both reference and working electrode include the same cation solvation/desolvation process, the effect of solvation energy on the measured potential cancels out. This means that measurements carried out in different electrolytes are directly comparable. Reference electrodes reversible to the cation in this way can be divided into 3 different categories: alloys, insertion type materials, or the metal itself.⁵

Several **alloy-type** reference electrodes including Li_xSn , Li_xAu and Li_xBi , have successfully been used as REs for Li-batteries.^{33–36} Electrochemical alloying can usually be carried out inside the cell, allowing for convenient preparation of the reference electrode.^{33,34} Another benefit is that the alloys can be prepared in the form of a wire, facilitating careful positioning of the RE inside the cell.⁵ These electrodes provide a stable potential over short to intermediate time intervals, but often experience potential drift over longer time periods (on the order of weeks) due to SEI-growth or self-delithiation. These processes are accelerated at elevated temperatures, making alloy-type electrodes unsuitable for such conditions.^{33,34} In this case it is recommended that the reference electrode is calibrated before and after the measurement with a reliable external reference, ferrocene for example, in order to estimate its potential drift.

Insertion type reference electrodes often avoid SEI-formation by having equilibrium potentials above the SEI-formation threshold.⁵ Given a sufficiently flat discharge profile, these materials can also be practically non-polarizable.⁷ The best example is $LiFePO_4$ (LFP), with a voltage plateau around 3.4 V (See Fig. 6a)⁹ that shows a very small polarization compared to other common Li-based reference electrodes when a current is passed through it (See Fig. 6b). Similarly, $Li_4Ti_5O_{12}$ (LTO), with a voltage plateau at 1.5 V, is also a suitable reference electrode for Li batteries.^{9,37} Unfortunately, insertion materials cannot usually be synthesized directly in a composition corresponding to the middle of the voltage plateau. Instead they need to be electrochemically lithiated and then partially delithiated to reach the desired composition.⁷

Despite a wide range of available Li-alloys and insertion materials, the most commonly used reference electrode is still metallic lithium.⁷ Generally, a RE should be a non-interacting bystander in the electrochemical cell. Li-metal on the other hand will spontaneously react with the electrolyte to form a solid-electrolyte interphase (SEI) on its surface. However, since this reaction stops when the SEI-layer becomes electronically insulating, Li-metal can provide a stable voltage as long as the SEI-layer is stable over time.⁴⁰

Research on post Li-batteries has increased drastically, making it necessary to develop reliable reference electrodes also for these battery chemistries. Metals like Na, K Mg and Ca commonly exhibit much more unstable potentials compared to Li, making them difficult to utilize as REs.^{8,39,38} Figures 6c and 6d illustrate the typically unstable OCV of symmetric cells built from these materials, often attributed to poor stability of the SEI-layer.^{8,38} However, it is important to note that if the surface of the electrode is conditioned in the right way, it might still be possible to use such metals as REs. Komaba et al. demonstrated how a slow plating/

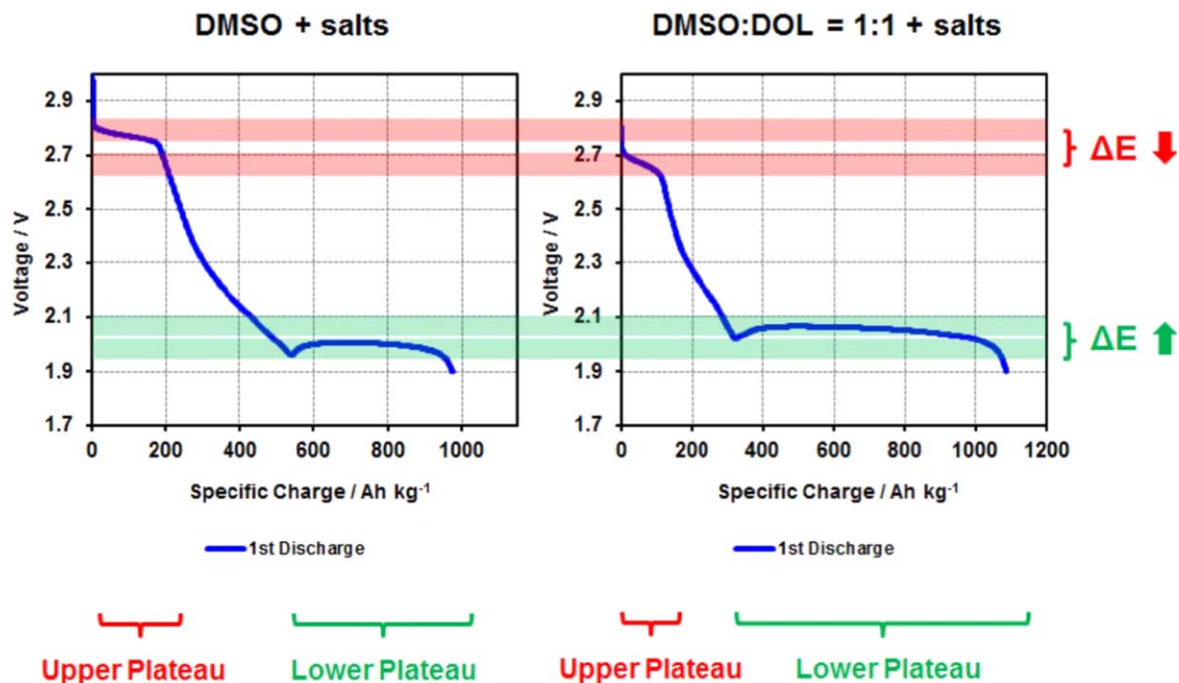

Figure 5. Effect of $\Delta G_{(\text{solv})}\text{Li}^+$ contribution to the observed voltage profiles during the reaction steps in a Li-S battery for two different electrolytes. Reproduced from.¹⁸

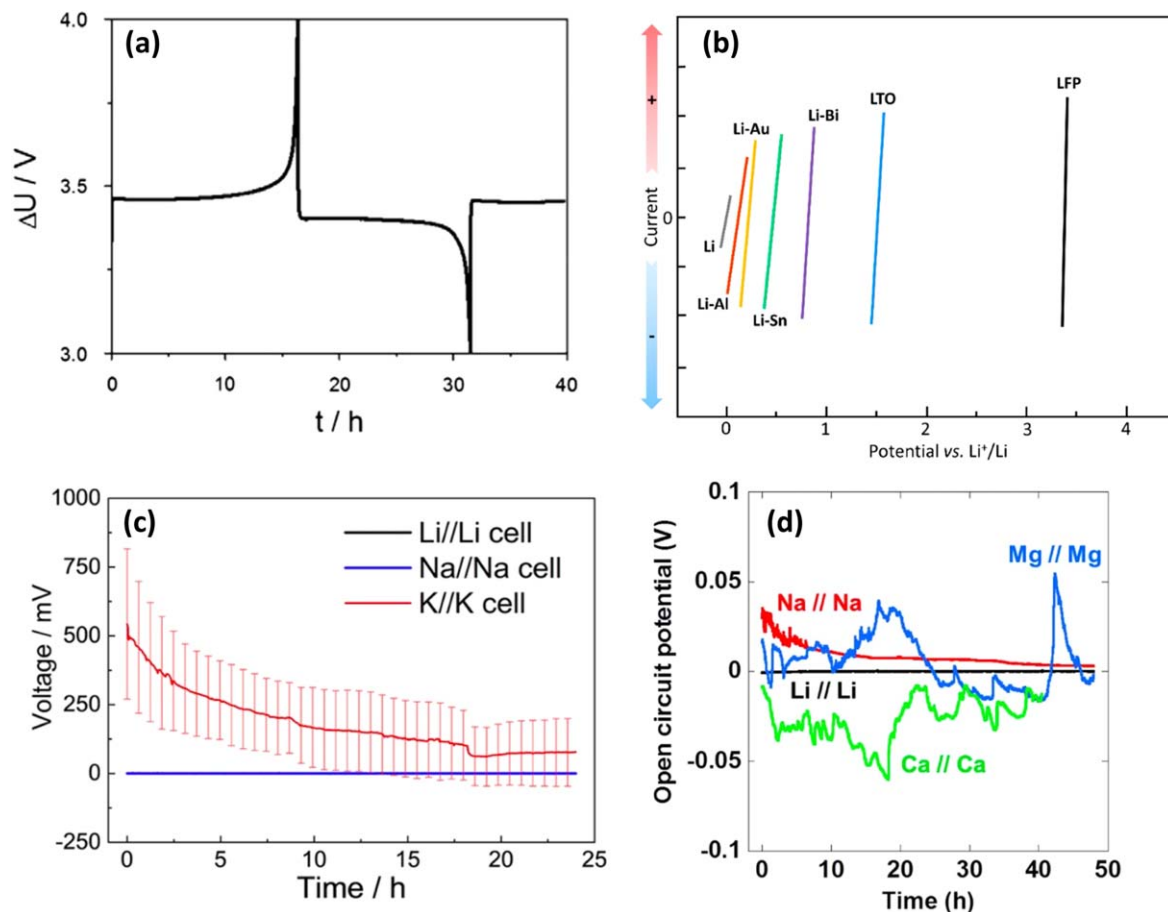

Figure 6. (a) Voltage profile of LFP vs Li, demonstrating the characteristic flat voltage plateau, reproduced from⁹ with permission. (b) Polarization of candidate Li reference electrodes, reproduced from,⁷ published under a creative commons CC-BY license. (c) OCV as a function of time for symmetric Li-, Na- and K-cells, reproduced from³⁸ with permission. (d) OCV as a function of time for symmetric Li-, Na-, Ca- and Mg-cells, reproduced from.³⁹

stripping cycle could replace the initial surface layer formed on K-metal inside the glove box with a stable SEI allowing the K-metal to act as an effective reference electrode.³⁸ In conclusion, metal electrodes can be used as reference electrodes in several systems, but the SEI layer needs to be stabilized to yield reproducible and reliable results.

Insertion type materials and metal alloys can also be considered as reference electrode materials for post Li-battery chemistries. Despite a number of candidate materials, implementation of these types of reference electrodes has so far proven challenging.⁵ For instance, Lee et al. attempted to use both an Na-Sn alloy and the insertion material nickel hexacyanoferrate, $\text{KNiFe}(\text{CN})_6$ a prussian blue analogue, as reference electrodes for Na-ion batteries. However, both these materials suffered from severe potential drift.⁴¹

As an alternative to the REs that are reversible to the cation, the potential can be measured vs a quasi-reference electrode. By definition, the redox reaction giving rise to the potential of a quasi-reference electrode is not well defined. This means that if the potentials measured during an experiment should be compared to measurements on other systems, an internal reference needs to be used.⁵ For this purpose, ferrocene is an excellent choice. The large size of ferrocene and its delocalized charge makes it possible to treat the ferrocene/ferrocenium ion redox potential as solvent independent.¹⁷ Thus, adding a small amount of ferrocene to an electrolyte enables quantitative measurements to be made even though the potential is measured vs a quasi-reference electrode, normally only permitting qualitative analysis. Ponrouch et al. proposed that a versatile reference electrode can be prepared by immersing an Ag wire in ammonium sulfide. They demonstrated that $\text{Ag}/\text{Ag}_2\text{S}$ provides a stable and reliable reference potential in Ca-based cell, and argue that it is a promising alternative that may also work in other systems.⁵ Another common quasi-reference electrode is activated carbon.^{42,43} For instance, Passerini and co-workers reported the use of an activated carbon quasi-reference electrode in Ca batteries.⁴³ However, the potential vs the quasi-reference electrode will be solvent dependent, which needs to be considered when measurements with different electrolytes are carried out and compared.

We also want to stress that careful selection of RE material might not be sufficient to obtain reliable results. It has frequently been reported that electrochemical performance, and particularly impedance spectra, can be distorted by factors like electrode misalignment, RE placement or cell geometry.^{37,44–46} A detailed account of these factors is, however, outside the scope of this review.

Conclusions

The correct understanding and use of reference electrodes are essential for accurate interpretations of phenomena in battery research. In this review we provide the physical background and guidelines to help researchers distinguish when a simpler cell configuration can be used and when more advanced setups are necessary to obtain reliable results. For half cells, a two-electrode configuration can be reliably used as long as there is not too much voltage polarization when a current is passed through the CE. This is the case with Li half cells when low or moderate current densities are applied. However, for high currents (above 1 mA cm^{-2} for lithium metal) or when half-cells with other metals (Na, K, Mg, Ca etc.) are used, the polarization can be problematic. However, this can be averted in three-electrode cells, where the current will not be passed through the reference electrode.

Even in a three-electrode configuration the potential of the reference electrode is not necessarily stable over time. To produce a stable and well-defined potential, the reference electrode must be in equilibrium with the species in the electrolyte that participate in the electrochemical reaction, otherwise the electrode is referred as a quasi- or pseudo-reference electrode, and its potential cannot not be well defined. A quasi-reference electrode can still serve as a reliable reference, but its potential should be calibrated using a stable

reference. For this purpose, the ferrocene/ferrocenium couple, a known and reliable external reference for non-aqueous electrolytes, is an excellent choice.

It is also important to consider that the reference electrode potential depends strongly on species concentration and the solvent. While the effect of concentration of species is generally well known and can be accounted for in the Nernst equation, many battery researchers are unaware of the effect of the solvent, particularly the Gibbs free energy of cation solvation, on the electrode potential. This voltage difference could be as large as 500 mV for the case of Li/Li^+ couple electrode potential in different solvents and if not accounted for could lead to wrong conclusions. Luckily, the potential difference caused by the difference in Gibbs free energy of solvation cancels out when the same ion solvation/desolvation takes place on both electrodes. This is the case for most half-cell configurations but there are many examples of battery systems, where the cation solvation energy is included in the final reaction, and therefore must be accounted for when comparing measurements in different electrolytes. Writing down reactions taking place on each electrode, and the overall reaction is a good practice in order to ensure correct interpretation of the obtained results.

Finally, we provide an overview of the reference electrodes used in the field, including metals, alloys and insertion materials. We believe that this review will be a useful guide for the battery researchers and will further promote the good practices in the Li-ion and next generation batteries research field, thus improving the reliability of the published data.

Acknowledgments

Funding provided by Swedish Research Council for Sustainable Development (FORMAS) and Batteries Sweden (BASE) is gratefully acknowledged.

ORCID

Elif Ceylan Cengiz  <https://orcid.org/0000-0002-8531-8290>

Natalia Mozshukhina  <https://orcid.org/0000-0001-6798-9704>

References

1. T. Vegge, J.-M. Tarascon, and K. Edström, *Adv. Energy Mater.*, **11**, 2100362 (2021).
2. K. Edström, R. Dominko, M. Fichtner, T. Otuszewski, S. Perraud, C. Punckt, J. Tarascon, T. Vegge, and W. Martin, (2020), BATTERY 2030+. Inventing the sustainable batteries of the future. Research needs and future actions..
3. A. Bhowmik, I. E. Castelli, J. M. Garcia-Lastra, P. B. Jørgensen, O. Winther, and T. Vegge, *Energy Storage Mater.*, **21**, 446 (2019).
4. T. Lombardo et al., *Chem. Rev.* (2021).
5. R. Dugas, J. D. Forero-Saboya, and A. Ponrouch, *Chem. Mater.*, **31**, 8613–8628 (2019).
6. R. Nölle, K. Beltrop, F. Holtstiege, J. Kasnatscheew, T. Placke, and M. Winter, *Mater. Today*, **32**, 131 (2020).
7. R. Raccichini, M. Amores, and G. Hinds, *Batteries*, **5**, 1 (2019).
8. D. I. Iermakova, R. Dugas, M. R. Palacín, and A. Ponrouch, *J. Electrochem. Soc.*, **162**, A7060 (2015).
9. F. La Mantia, C. D. Wessells, H. D. Deshazer, and Y. Cui, *Electrochem. Commun.*, **31**, 141 (2013).
10. J. O. B.-I. Claus Daniel Dr, *Handbook of Battery Materials* (Wiley, New York, NY) (2011).
11. Y. Marcus, *Pure Appl. Chem.*, **57**, 1129 (1985).
12. G. Inzelt, A. Lewenstam, and F. Scholz, *Handbook of Reference Electrodes* (Springer, Heidelberg) (2013).
13. A. A. J. Torriero, *Chem. Int. J.*, **3**, 3 (2019).
14. G. Gritzner and J. Küta, *Electrochim. Acta*, **29**, 869 (1984).
15. P. K. R. Kottam, D. Kalkan, M. Wohlfahrt-Mehrens, and M. Marinaro, *J. Electrochem. Soc.*, **166**, A1574 (2019).
16. R. Huston and J. N. Butler, *J. Phys. Chem.*, **72**, 4263 (1968).
17. N. Mozshukhina and E. J. Calvo, *J. Electrochem. Soc.*, **164**, A2295 (2017).
18. H. Schneider et al., *J. Electrochem. Soc.*, **161**, A1399 (2014).
19. D. Degoullange, N. Dubouis, and A. Grimaud, *J. Chem. Phys.*, **155**, 64701 (2021).
20. J. M. Cameron, C. Holc, A. J. Kibler, C. L. Peake, D. A. Walsh, G. N. Newton, and L. R. Johnson, *Chem. Soc. Rev.*, **50**, 5863 (2021).
21. A. G. Tamirat, X. Guan, J. Liu, J. Luo, and Y. Xia, *Chem. Soc. Rev.*, **49**, 7454 (2020).
22. K. P. C. Yao, J. T. Frith, S. Y. Sayed, F. Bardé, J. R. Owen, Y. Shao-Horn, and N. Garcia-Araez, *J. Phys. Chem. C*, **120**, 16290 (2016).

23. P. Ruschhaupt, S. Pohlmann, A. Varzi, and S. Passerini, *Batter. Supercaps*, **3**, 698 (2020).
24. J. Park, Z.-L. Xu, and K. Kang, *Front. Chem.*, **8**, 432 (2020).
25. P. K. Nayak, L. Yang, W. Brehm, and P. Adelhelm, *Angew. Chemie Int. Ed.*, **57**, 102 (2018).
26. Z.-L. Xu, G. Yoon, K.-Y. Park, H. Park, O. Tamwattana, S. Joo Kim, W. M. Seong, and K. Kang, *Nat. Commun.*, **10**, 2598 (2019).
27. H. Kim, J. Hong, G. Yoon, H. Kim, K.-Y. Park, M.-S. Park, W.-S. Yoon, and K. Kang, *Energy Environ. Sci.*, **8**, 2963 (2015).
28. B. Jache and P. Adelhelm, *Angew. Chemie Int. Ed.*, **53**, 10169 (2014).
29. M. Wang and Y. Tang, *Adv. Energy Mater.*, **8**, 1703320 (2018).
30. T. Placke, A. Heckmann, R. Schmich, P. Meister, K. Beltrop, and M. Winter, *Joule*, **2**, 2528 (2018).
31. P. G. Bruce, S. A. Freunberger, L. J. Hardwick, and J.-M. Tarascon, *Nat. Mater.*, **11**, 19 (2012).
32. W. R. Cieslak and F. M. Delnick, *J. Electrochem. Soc.*, **134**, 132 (1987).
33. D. P. Abraham, S. D. Poppen, A. N. Jansen, J. Liu, and D. W. Dees, *Electrochim. Acta*, **49**, 4763 (2004).
34. S. Solchenbach, D. Pritzl, E. J. Y. Kong, J. Landesfeind, and H. A. Gasteiger, *J. Electrochem. Soc.*, **163**, A2265 (2016).
35. J. L. Gómez-Cámer and P. Novák, *Electrochem. Commun.*, **34**, 208 (2013).
36. Y.-C. Chien, D. Brandell, and M. J. Lacey, "Towards reliable three-electrode cells for lithium-sulfur batteries." *Chem. Commun.* (2022).
37. J. Costard, M. Ender, M. Weiss, and E. Ivers-Tiffée, *J. Electrochem. Soc.*, **164**, A80 (2017).
38. T. Hosaka, S. Muratsubaki, K. Kubota, H. Onuma, and S. Komaba, *J. Phys. Chem. Lett.*, **10**, 3296 (2019).
39. D. S. Tchitchekova, D. Monti, P. Johansson, F. Bardé, A. Randon-Vitanova, M. R. Palacín, and A. Ponrouch, *J. Electrochem. Soc.*, **164**, A1384 (2017).
40. A. Blyr, C. Sigala, G. Amatuc, D. Guyonard, Y. Chabre, and J.-M. Tarascon, *J. Electrochem. Soc.*, **145**, 194 (1998).
41. S. E. Lee and M. H. Tang, *J. Electrochem. Soc.*, **166**, A3260 (2019).
42. P. W. Ruch, D. Cericola, M. Hahn, R. Kötz, and A. Wokaun, *J. Electroanal. Chem.*, **636**, 128 (2009).
43. X. Liu, G. A. Elia, and S. Passerini, *J. Power Sources Adv.*, **2**, 100008 (2020).
44. Y. Hoshi, Y. Narita, K. Honda, T. Ohtaki, I. Shitanda, M. Itagaki, and J. Power, *Sources*, **288**, 168 (2015).
45. Z. Chu, X. Feng, B. Liaw, Y. Li, L. Lu, J. Li, X. Han, and M. Ouyang, *J. Electrochem. Soc.*, **165**, A3240 (2018).
46. Y. Li, X. Han, X. Feng, Z. Chu, X. Gao, R. Li, J. Du, L. Lu, M. Ouyang, and J. Power, *Sources*, **481**, 228933 (2021).