

Optimal Pretreatment System of Flowback Water from Shale Gas Production

Alba Carrero-Parreño,[†] Viviani C. Onishi,^{*,†} Raquel Salcedo-Díaz,^{‡,†} Rubén Ruiz-Femenia,^{‡,†} Eric S. Fraga,[§] José A. Caballero,^{‡,†} and Juan A. Reyes-Labarta^{‡,†}

[†]Institute of Chemical Process Engineering and [‡]Department of Chemical Engineering, University of Alicante, Ap. Correos 99, Alicante 03080, Spain

[§]Centre for Process Systems Engineering, Department of Chemical Engineering, University College London, London WC1E 7JE, U.K.

S Supporting Information

ABSTRACT: Shale gas has emerged as a potential resource to transform the global energy market. Nevertheless, gas extraction from tight shale formations is only possible after horizontal drilling and hydraulic fracturing, which generally demand large amounts of water. Part of the ejected fracturing fluid returns to the surface as flowback water, containing a variety of pollutants. For this reason, water reuse and water recycling technologies have received further interest for enhancing overall shale gas process efficiency and sustainability. Water pretreatment systems (WPSs) can play an important role for achieving this goal. This paper introduces a new optimization model for WPS simultaneous synthesis, especially developed for flowback water from shale gas production. A multistage superstructure is proposed for the optimal WPS design, including several water pretreatment alternatives. The mathematical model is formulated via generalized disjunctive programming (GDP) and solved by re-formulation as a mixed-integer nonlinear programming (MINLP) problem, to minimize the total annualized cost. Hence, the superstructure allows identifying the optimal pretreatment sequence with minimum cost, according to inlet water composition and wastewater-desired destination (i.e., water reuse as fracking fluid or recycling). Three case studies are performed to illustrate the applicability of the proposed approach under specific composition constraints. Thus, four distinct flowback water compositions are evaluated for the different target conditions. The results highlight the ability of the developed model for the cost-effective WPS synthesis, by reaching the required water compositions for each specified destination.

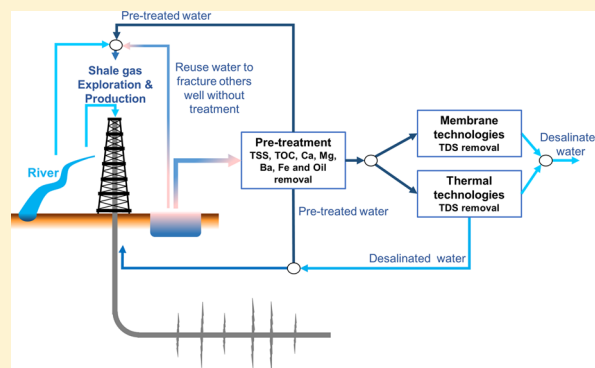

1. INTRODUCTION

Growth in natural gas production from tight shale formations is impacting the global energy market, despite environmental concerns about water resources.^{1–3} Although shale reserves can be found throughout the world, only North America, Argentina, and China are currently producing shale gas on a commercial scale.⁴ In the United States (U.S.), shale gas production is prognosticated to provide approximately 50% of the natural gas demand by 2040.⁵ This projection is based on the recent progress in horizontal drilling and hydraulic fracturing technologies for shale gas exploration.^{6–8}

Contrary to conventional gas production extracted from porous rocks, shale basins are characterized by their low permeability, which hampers gas displacement through rock formations.^{9,10} Horizontal drilling and hydraulic stimulation are necessary to release natural gas trapped into tight shale reservoirs. For this purpose, a fracking fluid mainly composed of water and sand (~98%) with a number of chemicals—including friction reducers, surfactants, corrosion inhibitors, flow improvers, etc.—is pumped into the well at high

pressure.^{11–13} Unconventional resources are only able to produce shale gas with economical profit after being horizontally drilled and hydraulically fractured.¹⁴ Nevertheless, drilling and stimulation processes usually demand large amounts of water.

It is estimated that shale gas production requires around 10500–21500 m³ (3–6 million US gallons) of water per well, in which about 10% is needed for horizontal drilling, while 90% is used in the fracking process.^{15,16} Between 10% and 80% of the injected fluid returns to the surface as flowback water, during the first 2 weeks after the start of the fracturing operation.^{17,18} The quantity of flowback water gradually decreases, remaining in a range of ~0.8–1.6 m³ h⁻¹ (~210–420 US gallons h⁻¹) after the first 15 days—average values obtained for important U.S. shale plays, including Marcellus,

Received: October 18, 2016

Revised: March 10, 2017

Accepted: March 22, 2017

Published: March 22, 2017

Barnett, Fayetteville, and Haynesville.¹⁹ Other authors report values of 8–15%²⁰ and 10–40%²¹ for the percentage of the injected water that flows back to surface after the initial period. From that, produced water (also referred as formation water due to the difficulty to differentiate it from the flowback water²²) is recovered together with shale gas during the period of well's exploitation (~20–40 years).¹⁵

Chemical and physical properties of shale gas flowback water are strongly dependent on different factors, including the shale formation geology, geographic location, contact time between the fracking fluid and rock, as well as inlet water composition used to fracture the well. Note that both the amount and composition of produced water can also vary throughout the well lifetime.^{9,19} Shale gas flowback water usually contains high concentrations of total dissolved solids (TDS)—comprising salt and other minerals, and scaling ions such as Ca, Mg, and Ba—in addition to total organic carbon (TOC) and total suspended solids (TSS), which includes oils, greases, fuels, and additives associated with the drilling and hydro-fracturing processes.^{11,12,23} Among all these contaminants, the high concentrations of TDS can range from 8000 mg L⁻¹ to more than 200 000 mg L⁻¹ with average values around 100 000 mg L⁻¹.^{9,21} Its removal is one of the most challenging because of the high-energy consumption required and strict regulations for water disposal or water reuse in other activities apart from hydraulic fracturing. Table 1 presents usual flowback water compositions from several shale gas wells in Barnett and Appalachian plays.

Table 1. Composition Data of Several Randomly Flowback Water from Barnett and Appalachian Plays^a

parameter	well 1	well 2	well 3	well 4
TDS	200006	54230	110847	9751
TSS	3220	881	1,530	168
TOC	200	89	138	38
Fe	92	60	105	40
Ca	14680	4800	3600	241
Mg	4730	1707	899	49
Ba	98	112	127	1
oil & grease	0	0	18	0

^aData extracted from ref 26; all values are given in mg L⁻¹.

In the above-mentioned scenario, water reuse and water recycling (i.e., water reuse in different activities to hydraulic fracturing) arise as attractive options for enhancing overall process efficiency and the sustainability of shale gas production. Typically, on-field water reuse corresponds to the less expensive strategy, decreasing freshwater demands, CO₂ footprint, and costs and contamination caused by transportation and brine disposal.⁹ In view of these benefits, one of the main interests of shale gas industry is to maximize the reuse of flowback water in drilling and fracking operations.^{24,25} Figure 1 schematically shows the set of all alternatives for shale gas flowback water management.

Despite the advantages of the on-field water reuse in shale gas operations, this practice can lead to operational problems due to the elevated level of contaminants that can compromise the well exploration.²⁶ Still, the direct water reuse for well reinjection can potentially be a source of pollution to shallow aquifers and surface waters.²⁷ An affordable solution is the implementation of an on-site pretreatment plant for allowing water reuse, and consequently, avoiding such operational

problems. The on-site water treatment option can include the removal of TSS, oil, grease, and scaling materials. In this case, transport cost is clearly negligible. Another alternative is the transportation of the flowback water to a centralized treatment plant with additional expenses.

Specifications for water reuse can be achieved through water pretreatment and/or freshwater blending, for reducing the concentration of some critical components (mainly TDS due to its related fluid viscosity effects).^{9,28} For this purpose, freshwater can be obtained from natural resources or from post-treatments plants of shale gas flowback water. Note that, to minimize the concentration of TDS in wastewater for water disposal and/or recycling, further water treatment (henceforth referred as desalination post-treatments) is required to ensure specific composition constraints.^{19,29}

As aforementioned, the TDS concentration is a key parameter and no widely accepted common standards have been reported.³⁰ According to Keister et al.,²⁹ from data collected from actual operators, TDS should not exceed 50 000–60 000 mg L⁻¹. This range is in accordance with the results provided by Kaden and Rose,³¹ based on 225 samples from 36 different wells in Marcellus play. However, some operators are reportedly considering the reuse of waters with salinity as high as 120 000 mg L⁻¹ TDS (with low hardness and scale-causing contaminants).¹⁹ Table 2 displays the main requirements for flowback water reuse in the Marcellus play.

Nowadays, due to the importance of water conservation, desalination post-treatments are receiving increased attention to avoid the freshwater usage. The goal of these post-treatment processes is to remove TDS contents from the shale gas flowback water, allowing its recycling as clean water.^{32,33} Different desalination processes can be used for removing TDS contents from shale gas flowback water, e.g., membrane and thermal-based technologies. Obviously, each of these processes should operate under specific water composition constraints for preventing damage and/or to avoid impacting equipment performance. On the one hand, regarding membrane-based desalination technologies, reverse osmosis (RO) can be considered to treat flowback water with TDS concentrations below 40 000 mg L⁻¹,³⁴ whereas membrane distillation (MD) can be applied for higher salinities.^{35–37} On the other hand, thermal technologies such as multistage flash (MSF) and multiple-effect evaporation with/without mechanical vapor recompression (MEE-MVR) are extensively used in industry, due to their applicability to high-salinity conditions and need for simpler pretreatment processes.⁹

Water pretreatment systems (WPSs) of flowback water from shale gas production can be composed of several well-established water treatment alternatives (e.g., filtration, coagulation, flocculation, dissolved air flotation (DAF), electrocoagulation, softening, sedimentation, membrane treatments, etc.). Currently, there are different commercial processes for WPS, with their corresponding characteristics and limitations. An important review on the environmental risks and treatment strategies for the shale gas flowback water is addressed to Estrada and Bhamidimarri.³⁰ Michel et al.³⁴ have carried out an experimental research on the treatment of flowback water from shale gas production. In their work, a two-stage water treatment process composed of pretreatment and desalination has been developed. In the pretreatment step, the authors have considered the following sequence of treatment: filtration, pH adjustment, oxidation, and sedimentation, while nanofiltration/RO have been performed at the desalination stage. Their results

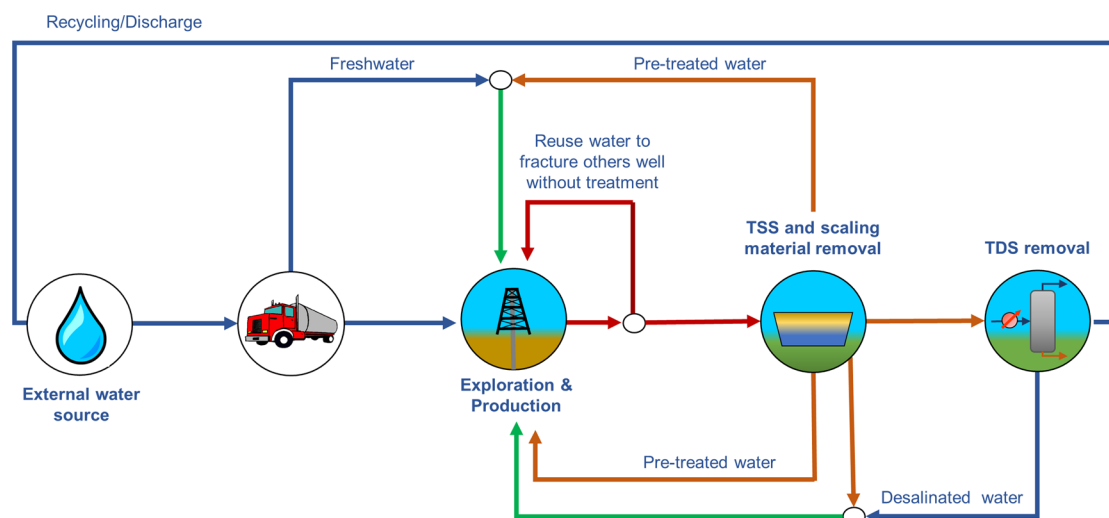

Figure 1. Alternatives for the management of shale gas flowback water: direct on-field reuse, pretreatment to allow desalination or indirect reuse, or disposal.

Table 2. Main Specifications for Flowback Water Reuse in Marcellus Shale Play

parameter	maximum value recommended	
	<i>a</i>	<i>b</i>
TSS (mg/L)	50	
total hardness (mg/L)	2500	26 000
total alkalinity (mg/L)		300
TDS (mg/L)	50 000–65 000	50 000
TOC (mg/L)	<25	
pH	6–8	
bacteria (/mL)	<100	
chloride (mg/L)	20 000–30 000	45 000
sulfates (mg/L)		50
calcium (mg/L)		8000
magnesium (mg/L)		1200
sodium (mg/L)		36 000
potassium (mg/L)		1000
iron (mg/L)	20	10
barium (mg/L)		10
strontium (mg/L)		10
manganese (mg/L)		10

^aData extracted from refs 19 and 29. ^bICG Industrial contact group. Data compiled by Kaden and Rose.³¹

highlight the intensive pretreatment requirements before membrane-based desalination becomes possible. Also, Cho et al.³⁸ have investigated the use of antiscalants to reduce scale formation in MD desalination of shale gas flowback water.

In the Process Systems Engineering (PSE) field, Beery et al.³⁹ have studied the application of life cycle assessment (LCA) together with computational tools for the design of different pretreatment processes for RO desalination of seawater. Later, Beery et al.⁴⁰ have developed a software tool in Excel based on LCA principles, to allow the estimation of environmental impacts in seawater pretreatment and subsequent RO desalination processes. In a posterior work, Beery et al.⁴¹ developed a process design tool for seawater pretreatment aimed at RO desalination, including synthesis, simulation and evaluation of costs and carbon footprint. The authors have proposed a knowledge-based algorithm—focused on previous experimental investigation conducted by the authors⁴²—for the

process flowsheet decision, considering several pretreatment technologies (e.g., coagulation, flocculation, sedimentation, granular filtration, and cartridge filtration). Notwithstanding, it should be emphasized that the seawater pretreatment processes considered by the authors have not been optimized, which can lead to suboptimal solutions.

To the best of our knowledge, there are no systematic mathematical modeling approaches for synthesizing the optimal set of alternatives for WPS, applied to shale gas production. Hence, this paper introduces a new mathematical model for optimal WPS design for shale gas flowback water. Thus, the proposed model is formulated using generalized disjunctive programming (GDP) and optimized via mixed-integer nonlinear programming (MINLP) re-formulation, to minimize the process total annualized cost. A multistage superstructure is proposed for the simultaneous WPS synthesis, including several water pretreatment alternatives. The main goal of this work is to obtain an optimal WPS design with minimum cost, according to different inlet water compositions and specified composition constraints (which depends on the wastewater-desired destination: water reuse as fracking fluid or water recycling). As each desired destination requires specific composition constraints, several case studies are performed to evaluate the applicability of the proposed approach under different conditions.

The main novelties introduced by this study comprise (i) a collection of the main water pretreatment technologies used in shale gas industry within a more comprehensive multistage superstructure, (ii) a detailed cost analysis embracing all water pretreatment alternatives, and (iii) global optimization of WPS design, considering a large range of feedwater compositions and specific composition constraints for each wastewater-desired destination.

The rest of the work is organized as follows: Section 2 formally describes the problem statement, whereas the proposed superstructure is presented in section 3. In section 4, the MINLP-based model is developed in detail. The results obtained are presented in section 5 with a proper critical appraisal. Finally, the last section summarizes the main achievements.

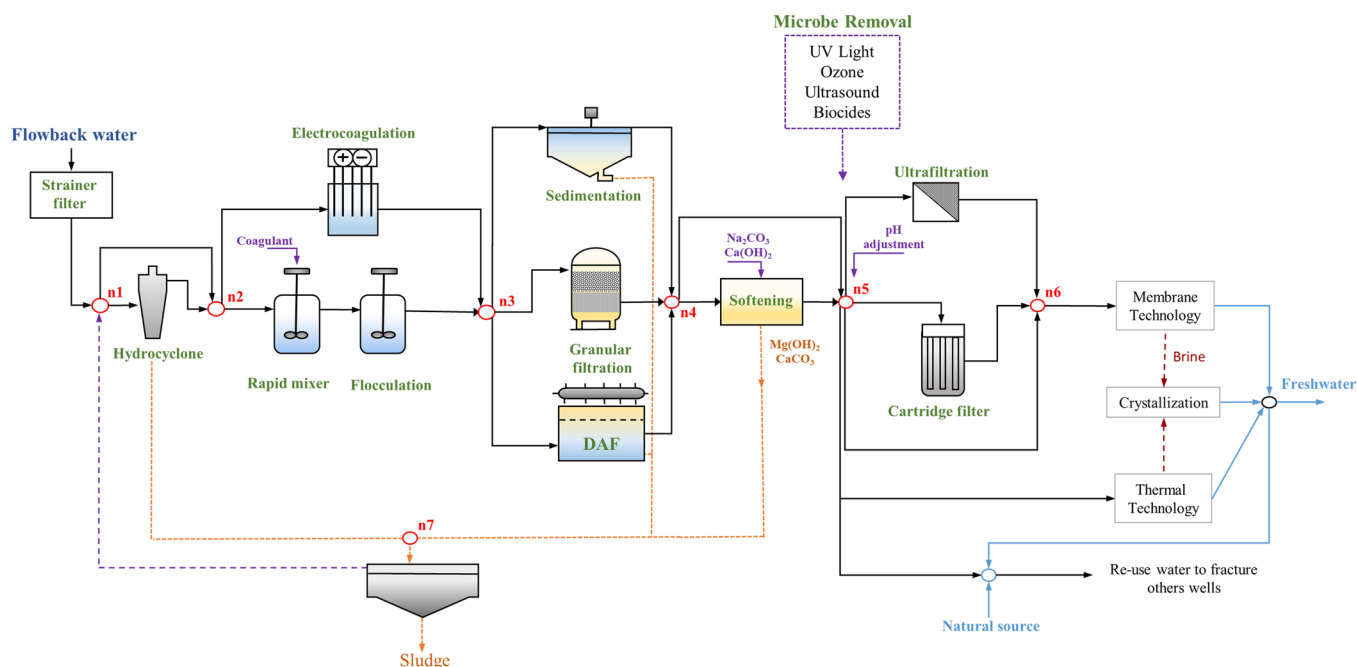

Figure 2. Multistage superstructure for water pretreatment system (WPS) of flowback water from shale gas production. The selection of the equipment in the superstructure was carried out on a stage-by-stage heuristic basis, to safeguard the workability of each upcoming stage (e.g., ultrafiltration is only possible after electrocoagulation/flocculation and sedimentation/filtration/flotation process).

2. PROBLEM STATEMENT

Given is a shale gas flowback water stream with known inlet state (mass flow rate, density, temperature, and concentrations of TDS, TSS, TOC, Fe, Ca, Mg, Ba, and oil), target condition (defined by the wastewater-desired destination), and a set of water pretreatment technologies with their corresponding capital and operational costs. The objective is to identify the optimal sequence (minimum total annualized cost) of water pretreatment units that meet the final water specifications according to the desired treated water destination.

The set of water pretreatment technologies includes the following equipment (or unitary operation): strainer filter, hydrocyclone, electrocoagulation, flocculation, sedimentation, granular filtration, DAF, softening, ultrafiltration, cartridge filter, and filter press. For the detailed cost analysis, the contributions of the capital investment in all equipment that composes the WPS and related operational expenses are considered in the objective function.

It is worth mentioning that in this work, the presence of Normally Occurring Radioactive Materials (NORMs) has not been taken into account. These materials include uranium, thorium, or radium (^{226}Ra , ^{228}Ra). Due to their higher solubility, radium isotopes are the most important.⁴³ Fortunately, in wastewater from shale gas production, NORMs are, in general, very far away from the limits of dangerous concentrations. For example, Almond et al.⁴³ studied the radioactivity in flowback water from three areas: the Bowland shale in the U.K., the Silurian shale in Poland, and the Barnett shale in the USA. They conclude that in the worst-case scenario, the 1% exceedance exposure greater than 1 mSv was not surpassed, which is the allowable annual exposure in the U.K. Moreover, the radiation per energy produced was lower for shale gas than for conventional oil and gas production, nuclear power production, or electricity generated from burning coal. In the case in which NORMs were important,

Silva et al.⁴⁴ described feasible alternatives for precipitation and removal of radioactive materials.

3. WPS SUPERSTRUCTURE

A knowledge-based superstructure composed of six stages is proposed for the optimal WPS design, including several water pretreatment alternatives. In each stage, different water pretreatment technologies should be used to ensure the target water condition. The requirements on the final components concentrations are specified by the wastewater-desired destination (i.e., water reuse or water recycling). Thus, the selection of the superstructure equipment was performed on a stage-by-stage heuristic basis, to safeguard the workability of each upcoming stage. For instance, coagulation/flocculation should come before of sedimentation, membrane or cartridge filtration. The latter alternatives, mainly ultrafiltration, are also only possible after sedimentation/DAF/filtration. Figure 2 displays the multistage superstructure proposed to solve the problem.

A strainer filter composes the first stage of the superstructure for removing larger particles and mud from the shale gas flowback water (henceforth denominated as feedwater). In the second stage (node 1), the feedwater stream can pass through the hydrocyclone or bypass. This decision depends on the inlet TSS composition in the water to be treated in the system. Hydrocyclones are important equipment for solid–liquid separation due to their simple design, low capital investment, low maintenance, and easy operation.⁴⁵

In the third stage (node 2), a decision should be made between coagulation and flocculation or electrocoagulation processes. In general, the coagulation process is preferable due to its lower capital and operational costs in comparison with other available methods. In this process, coagulants are used to induce TSS and TOC growth, including metal salts (typically Fe and Al) and polymers. However, the EC process emerges as a potential technology for the pretreatment of shale gas

flowback water, due to its ability to remove particles that are usually difficult to separate by other conventional treatments (including filtration and chemical treatments). Additionally, EC provides active cations without growing the salinity of the water.^{46,47} In this work, the pH control necessary for operating these units in different conditions is implicitly included in each unit operation.

The objective of the fourth stage (node 3) is to eliminate the particles/flocs formed in previous stages of the WPS. Three different water treatment alternatives are considered in this stage: sedimentation, granular filtration, and DAF. Sedimentation is the cheapest option, but its efficiency is lower than that of granular filtration and DAF. Granular filtration is the most efficient option in this stage mainly for TSS concentrations ranging from 50 to 100 mg L⁻¹.²⁵ Nevertheless, this process needs continuous backwashing to avoid decreasing of equipment efficiency. For these reasons, DAF is the usual method for eliminating oil and suspended solids.⁴⁸

In stage 5 (node 4), there are two different possibilities. The water could be treated by a softening process and/or it could pass through a bypass. These two alternatives are not excluding. In other words, part of the water can be treated, while the rest can pass through the bypass. The selection should be made on the basis of the presence of scale forming cations (Ca, Mg, Ba, etc.). These contaminants can produce fouling in pipes by the increase in the temperature, promoting the diminution of the performance of the thermal technologies. The most common softening method is the cold lime-based process. In this case, lime (Ca(OH)₂) is added to remove Mg and carbonates. Noncarbonates or permanent calcium is precipitated with soda ash (Na₂CO₃). Still, the pH should be adjusted to 4 to stabilize the scale forming cations.²⁶

In the stage 6 (node 5), the shale gas flowback water can be treated by ultrafiltration or a cartridge filter. This stage is considered in the superstructure because the water can be reused to fracture other wells, or it can be further treated for recycling (by thermal or membrane-based desalination technologies). As membrane-based desalination methods are very sensitive to the feed composition, the last stage acts as a protection barrier against microparticles that could foul and/or damage the membrane system elements.^{49,50} Disinfection is critical for fracturing fluids because an excess of bacteria can produce equipment corrosion and cause the formation of sour (H₂S) fluids.⁵¹ Bacteria can be destroyed using various technologies such as ultraviolet light, ozone, ultrasound or biocides.²⁷

Some of the above-mentioned operations produce sludge with different solid concentrations (from some typical values of 45% w.w. in sedimentation to 5% w.w. in DAF). To recover as much water as possible to reach the objective of zero liquid discharge (ZLD), the sludge from different technologies is sent to a filter press and the water produced by filtration is returned to the WPS to be further treated.

Due to the lack of correlations to predict the behavior of all components in each treatment unit, the aforementioned equipment are mathematically modeled via short-cut models based on contaminants' removal ratios. The mathematical model is developed in the following sections.

4. MATHEMATICAL PROGRAMMING MODEL

The mathematical model is formulated using GDP and optimized as a MINLP problem, wherein binary variables represent the discrete decisions about the existence or selection

of an equipment (water pretreatment technology) in a stage of the superstructure. It comprises the design equations for each water treatment technology considered in the superstructure, including mass balances at each node, sizing and costing equations, unit design equations, and the objective function (minimization of the total annualized cost). In addition, outlet water conditions (i.e., wastewater obtained after the pretreatment sequence) should satisfy some requirements defined by its desired destination (i.e., water reuse or water recycling). Therefore, these composition requirements should be expressed as design constraints in the optimization model.

To clearly develop the problem, the following index sets are defined:

$$C = \{c/c \text{ is a feed water component}\}$$

$$[TDS; TSS; TOC; Fe; Ca; Mg; Ba; oil; H_2O]$$

$$T = \{t/t \text{ is a pretreatment unit}\}$$

$$[sf = \text{strainer filter}; hy = \text{hydrocyclone}; co = \text{coagulation}; flo = \text{flocculation}; ec = \text{electrocoagulation}; sd = \text{sedimentation}; gf = \text{granular filtration}; df = \text{dissolved air flotation}; sof = \text{softening}; uf = \text{ultrafiltration}; cf = \text{cartridge filtration}; pf = \text{press filter}; b1 = \text{bypass1}; b2 = \text{bypass2}]$$

$$N = \{n/n \text{ is a node}\}$$

$$[\text{nodes } n1 \text{ to } n7]$$

$$R = \{r/r \text{ are the post-treatment desalination alternatives or water reuse}\}$$

$$[MT = \text{membrane treatment}; TT = \text{thermal treatment}; WR = \text{water reuse}]$$

$$IN_{t,n} = \{\text{outlet stream from a technology } t \text{ is an input to node } n\}$$

$$OUT_{t,n} = \{\text{inlet stream to technology } t \text{ is an output from node } n\}$$

$$SLU_t = \{\text{sludge stream from technology } t \text{ (if any) is an input to pf}\}$$

The following data are assumed to be known:

$$F^{\text{food_water}} \quad \text{water flowrate (m}^3 \text{ h}^{-1}\text{)}$$

$$c_c^{\text{food}} \quad \text{concentration of contaminant } c \text{ in feed stream}$$

$$F_c^{\text{food}} \quad \text{individual flow rate of component } c \text{ (m}^3 \text{ kg h}^{-1}\text{)}$$

$$u_t \quad \text{set of specific design parameters for equipment } t \text{ (e.g., loading rate of sedimentation or DAF, etc.)}$$

$$g_t \quad \text{weight fraction of solids in outlet sludge stream for equipment } t$$

$$a_{cs} \quad \text{removal factor of component } c \text{ in equipment } t$$

$$DT_t \quad \text{detention time (min) for coagulation, flocculation, electrocoagulation, and softening}$$

$$r \quad \text{feed water density (kg m}^{-3}\text{)}$$

$$LR_t \quad \text{loading rate of sedimentation, flotation, granular filtration, and strainer filter (m h}^{-1}\text{)}$$

4.1. Mass Balance in the First Stage. The mass balance in the first stage of the superstructure is defined by the following equation.

$$F_c^{\text{feed}} = F_{c,sf}^{\text{in}} \quad \forall c \in C \quad (1)$$

4.2. Mass Balances in the Nodes (Nodes 1–7). The mass balances in nodes 1–6 are given by the following equation.

Table 3. Removal Factors for each Component in the Water Pre-treatment Equipment

components (c)	hy ^d	co-sd ^e	technologies (t)							
			ec-sd ^e	co-gf ^e	ec-gf ^e	co-df ^{f,g}	ec-df ^{f,g}	uf-cf ^{f,g}	sof ^g	fp ^d
TSS	73	37.5	97.2	37.5	97.2	37.5	97.2	100		90
TOC		51	19	51	19	51	19	90		90
Fe		8	84	8	84	8	84	90		90
Ca			37					37	100	90
Mg									100	90
Ba									100	90
oil						100	100	99		90

^dData extracted from refs 54. ^eData extracted from ref 72. ^fData extracted from ref 73. ^gData extracted from ref 74.

$$\sum_{t \in \text{IN}_{i,n}} F_{c,t} = \sum_{t \in \text{OUT}_{i,n}} F_{c,t} \quad \forall c \in C, n \in N \neq n7 \quad (2)$$

In node 4, the outlet flow could pass through both alternatives softening and bypass. Consequently, eq 3 must be added.

$$F_{c,t}^{\text{out}} \sum_{t \in \text{IN}_{i,n}} F_{c,t} = F_{c,t} \cdot \sum_{t \in \text{OUT}_{i,n}} F_{c,t} \quad \forall c \in C, n \in N = n4 \quad (3)$$

The mass flow rate at the entrance of the filter press (node 7) is expressed by eq 4.

$$F_{c,\text{pf}}^{\text{in}} = \sum_{t \in \text{SLU}_i} F_{c,t} \quad \forall c \in C \quad (4)$$

Note that, to avoid bilinear terms (e.g., the product of the variables mass flow rate by concentration), mass balances in eqs 1, 2, and 4 have been written in terms of flows of individual components. Bilinear terms introduce nonconvexities that strongly hinder obtaining the global optimal solution. Thus, the number of such nonconvexities has been minimized in the model.

4.3. Equipment Design. The design equations related to a given pretreatment technology should be active only if the related equipment is selected in the WPS. Otherwise, the mass flow rates, equipment capacities, and all variables associated with the referred unit should be equal to zero. For this purpose, Boolean variables Y_t (that takes the value «True» if the technology t is selected and «False», otherwise) are defined, and the following disjunctions are introduced:

$$\left[\begin{array}{l} Y_t \\ F_{c,t}^{\text{in}} = F_{c,t}^{\text{out}} + F_{c,t}^{\text{slud}} \quad \forall c \in C \\ (\text{sizing parameters})_t = f(F_{c,t}^{\text{in}}, u_t) \\ (1 - \gamma_t) \cdot \sum_{c \notin \text{H}_2\text{O} \in \text{SLU}_t} F_{c,t} \\ F_{\text{H}_2\text{O},t}^{\text{slud}} = \frac{\quad}{\gamma_t} \\ F_{c,t}^{\text{out}} = (1 - \alpha_{c,t}) \cdot F_{c,t}^{\text{in}} \end{array} \right] \vee \left[\begin{array}{l} \neg Y_t \\ F_{c,t}^{\text{in}} = F_{c,t}^{\text{out}} = F_{c,t}^{\text{slud}} = 0 \quad \forall c \in C \\ (\text{sizing parameters})_t = 0 \end{array} \right] \quad \forall t \in \{\text{sf}, \text{hy}, \text{co}, \text{flo}, \text{ec}, \text{sof}, \text{uf}, \text{cf}, \text{pf}\} \quad 0 \leq F_{c,t}^{\text{in}} \leq F_c^{\text{UP}} \quad (5)$$

$$\left[\begin{array}{l} Y_t \\ F_{c,t}^{\text{in}} = F_{c,t}^{\text{out}} + F_{c,t}^{\text{slud}} \quad \forall c \in C \\ (\text{sizing parameters})_t = f(F_{c,t}^{\text{in}}, u_t) \\ (1 - \gamma_t) \cdot \sum_{c \notin \text{H}_2\text{O} \in \text{SLU}_t} F_{c,t} \\ F_{\text{H}_2\text{O},t}^{\text{slud}} = \frac{\quad}{\gamma_t} \\ \left[F_{c,t}^{\text{out}} = (1 - \alpha_{1,t}) \cdot F_{c,t}^{\text{in}} \right] \vee \left[F_{c,t}^{\text{out}} = (1 - \alpha_{2,t}) \cdot F_{c,t}^{\text{in}} \right] \\ \left[\begin{array}{l} \neg Y_t \\ F_{c,t}^{\text{in}} = F_{c,t}^{\text{out}} = F_{c,t}^{\text{slud}} = 0 \quad \forall c \in C \\ (\text{sizing parameters})_t = 0 \end{array} \right] \end{array} \right] \vee \left[\begin{array}{l} \neg Y_t \\ F_{c,t}^{\text{in}} = F_{c,t}^{\text{out}} = F_{c,t}^{\text{slud}} = 0 \quad \forall c \in C \\ (\text{sizing parameters})_t = 0 \end{array} \right] \quad \forall t \in \{\text{sd}, \text{df}, \text{gf}\} \quad 0 \leq F_{c,t}^{\text{in}} \leq F_c^{\text{UP}} \quad (6)$$

In the left term of the disjunction given by eqs 5 and 6, the first equation represents the mass balance in the technology t , in which $F_{c,t}^{\text{in}}$, $F_{c,t}^{\text{out}}$, and $F_{c,t}^{\text{slud}}$ are, respectively, the inlet, outlet, and sludge flow of component c and technology t . The second one is the sizing equations to estimate the critical design parameters (usually the volume or area) of each unit. It depends on the inlet flow rate and specific design parameters « u_t » (e.g., detention times, loading rates, etc.). The design variables are required for the equipment sizing and estimation of capital investment. The third equation calculates the water in the sludge stream. It is written in terms of weight fraction of solids in the sludge stream (γ_t) for each technology.^{44,52,53}

The relation between inlet and outlet mass flow rates is modeled by using removal factors ($\alpha_{c,t}$). These removal factors can be based on heuristics, manufacture recommendations, and/or the literature. See Beery et al.⁴² for TSS removal by granular media filters (~93%); Fakhru'l-Razi et al.⁵⁴ for oil removal (~92%–97%), TOC (98%) and scale inhibition via coagulation, oil removal via DAF (99.3%–99.9%), and TOC (~98%) and oil (>99%) removal efficiencies by ultrafiltration; Houcine⁵⁵ for heavy metal removal through lime softening (>95%); and Bilstad and Espedal⁵⁶ for oil removal via hydrocyclones (>90%). Additionally, in this work the removal efficiencies for all components via a filter press is considered equal to 90%.⁵⁴ A summary of all the removal factors can be found in Table 3. Clearly, these factors can be easily changed in the model.

An embedded disjunction has been described in eq 6, to include two different removal factors for sedimentation, DAF, and granular filtration, depending on whether the flocs are formed by coagulation or electrocoagulation. The model is solved by re-formulating the disjunctive representation of the problem as a MINLP model. For this purpose, a hull re-

formulation is used.⁵⁷ First, a set of binary variables (y_t) is defined so that it will take the value 1 if the Boolean variable Y_t takes the value of «True» and zero, otherwise. The equations form the re-formulations of disjunctions eq 5 and the common part in eq 6 are the following:

$$\begin{aligned}
 F_{c,t}^{in} &= F_{c,t}^{out} + F_{c,t}^{slud} \quad \forall c \in C; \forall t \in T \\
 (\text{sizing parameters})_t &= ((1 - \varepsilon)\gamma_t + \varepsilon)f \\
 &\left(\frac{F_t^{in}}{((1 - \varepsilon)\gamma_t + \varepsilon)}, u_t \right) - \varepsilon f(0)(1 - \gamma_t) \quad \forall t \in T \\
 F_{6H_2O,t}^{slud} &= \frac{(1 - \gamma_t) \sum_{c \neq 6H_2O, t \in SLU_t} F_{c,t}}{\gamma_t} \quad \forall t \in T \\
 \left. \begin{aligned}
 F_{c,t}^{out} &= (1 - \alpha_{c,t})F_{c,t}^{in} \\
 F_{c,t}^{in} &\leq F_c^{UP} \gamma_t \\
 F_{c,t}^{out} &\leq F_c^{UP} \gamma_t \\
 F_{c,t}^{slud} &\leq F_c^{UP} \gamma_t
 \end{aligned} \right\} \quad \forall c \in C; \forall t \in T \\
 F_{c,t}^{out} &\geq 0; F_{c,t}^{in} \geq 0; \gamma_t \in \{0, 1\}
 \end{aligned} \tag{7}$$

The second equation in eq 7 corresponds to the general hull re-formulation. See Trespalacios and Grossmann⁵⁸ for a detailed explanation of this re-formulation in the case of nonlinear equations. If the size equation is linear, then the binary variables appear only multiplying constant terms.

For the embedded terms in disjunction eq 6, it is needed to define two new binary variables y_1 and y_2 . The re-formulation is as follows:

$$\begin{aligned}
 \gamma_t &= y_{1,t} + y_{2,t} \quad \forall t \in \{sd, df, gf\} \\
 \left. \begin{aligned}
 F_{c,t}^{out} &= F1_{c,t}^{out} + F2_{c,t}^{out} \\
 F_{c,t}^{in} &= F1_{c,t}^{in} + F2_{c,t}^{in} \\
 F1_{c,t}^{out} &= (1 - \alpha_{1,c,t})F1_{c,t}^{in} \\
 F2_{c,t}^{out} &= (1 - \alpha_{2,c,t})F2_{c,t}^{in} \\
 F1_{c,t}^{in} &\leq F_c^{UP} y_{1,t} \\
 F1_{c,t}^{out} &\leq F_c^{UP} y_{1,t} \\
 F2_{c,t}^{in} &\leq F_c^{UP} y_{2,t} \\
 F2_{c,t}^{out} &\leq F_c^{UP} y_{2,t}
 \end{aligned} \right\} \quad \forall t \in \{sd, df, gf\} \forall c \in C \\
 F_{c,t}^{out} &\geq 0; F1_{c,t}^{out} \geq 0; F2_{c,t}^{out} \geq 0 \\
 F_{c,t}^{in} &\geq 0; F1_{c,t}^{in} \geq 0; F2_{c,t}^{in} \geq 0 \\
 \gamma_t &\in \{0, 1\}; y_{1,t} \in \{0, 1\}; y_{2,t} \in \{0, 1\}
 \end{aligned} \tag{8}$$

The equipment sizing equations and design constraints are presented in following sections.

4.3.1. Sizing Equations. The equipment volumes for coagulation, flocculation, electrocoagulation, and softening processes are calculated as follows.

$$V_t = \frac{DT_t}{\rho} \cdot \sum_{c \in C, t \in IN_{t,n}} F_{c,t} \in \{co, flo, ec, sof\} \tag{9}$$

In which DT is the detention time in minutes for the equipment t. A detention time equal to 30 min is used to model the flocculation and electrocoagulation units, whereas 5 and 15 min are considered for coagulation and electrocoagulation, respectively.^{19,48,59} ρ indicates the feedwater density considered as a design parameter in the mathematical model.

Equipment for sedimentation, DAF, granular filtration and filter press are typically designed by considering the loading rate (LR) for the equipment t. Data based on experience show that typical LR values are equal to 3 m h⁻¹ for sedimentation, 10 m h⁻¹ for DAF, 10 m h⁻¹ for filter media, and 3 m h⁻¹ for filter press.⁴⁸ The transversal area of these equipment is given by the next equation.

$$A_t = \frac{1}{\rho \cdot LR_t} \cdot \sum_{c \in C, t \in IN_{t,n}} F_{c,t} \quad t \in \{sd, daf, gf, sf\} \tag{10}$$

There are many empirical models in literature for the design of hydrocyclones. The model proposed by Vieira et al.⁶⁰ is used in this work:

$$D_{hy} = 0.01 \cdot \left(14 \frac{\rho_p - \rho}{4500 \cdot \tau} \right)^{0.33} \cdot \sum_{c \in C, t \in IN_{t,n}} \left(\frac{F_{c,t}}{\rho} \right)^{0.17} \tag{11}$$

in which D_{hy} is the hydrocyclone diameter, τ is the fluid dynamic viscosity, and ρ_p is the particle density. The volume of the hydrocyclone can be calculated as follows.

$$V_{hy} = 1.096 \cdot D_{hy}^3 - 0.346 \tag{12}$$

4.3.2. Design and Specification Constraints. Some separation technologies have constraints related to their performance, or the type of components they can deal with. In particular, granular filtration works more effectively when the TSS concentration is lower than 100 mg L⁻¹.⁴² Therefore, the following constraint should be added to the WPS model to avoid equipment clogging:

$$F_{TSS,gf}^{in} \leq \frac{0.1}{\rho} \cdot \sum_{c \in C} F_{c,gf} \tag{13}$$

Specification constraints are still necessary to ensure that the required composition is achieved for each desired destination (i.e., water reuse or desalination treatments such as thermal or membrane-based technologies). Note that the requirements for water reuse to fracture other wells are company dependent (Table 2). As aforementioned, if membrane technologies are considered for the treatment (desalination) of the wastewater, it is essential to reduce TSS, iron, oil, and forming particles to avoid fouling problems.³⁸ In fact, membrane fouling can cause reduction in the treated flow, as well as an increase in the operating pressure, requiring expensive cleaning cycles. Additionally, membrane-based technologies are not able to treat water with TDS containing higher than 40 000–45 000 mg L⁻¹.^{9,34} Thus, thermal technologies can be applied for water post-treatment with higher TDS contents, which can ensure the recycling water quality. However, the levels of scale forming ions should be reduced to prevent equipment problems caused

Table 4. Cost Correlations for Estimation of Capital Investment of Water Pre-treatment Systems^a

description (t)	capital cost (US\$) ^a	variable	units
hydrocyclone (hy)	4590.2V + 15495	volume	m ³
rapid mixer (co)	1103.4V + 28829	volume	m ³
flocculation (flo)	-V ² + 1201.8V + 30200.6	volume	m ³
electrocoagulation tank (ec)	3884.2V + 10203.8	volume	m ³
sedimentation (sd)	1363.1A + 76934.1	area	m ²
granular filtration (gf)	-27.6A ² + 1794.8A + 268109.7	area	m ²
DAF (df)	-0.38A ² + 2890.5A + 125478.5	area	m ²
ultrafiltration (uf)	10.9 $\sum_{c \in C} F_j^{\text{in}}$ + 45356.8	inlet flow	kg h ⁻¹
cartridge filtration (cf)	310 ⁻⁶ ($\sum_{c \in C} F_j^{\text{in}}$) ² - 0.0359 $\sum_{c \in C} F_j^{\text{in}}$ + 1697	inlet flow	kg h ⁻¹
filter press (pf)	-0.95A ² + 1088.4A + 107858	area	m ²

^aCost correlations have been updated to 2015 (CEPCI = 556.8).

by temperature changes. Moreover, the presence of oil should also be decreased to prevent equipment inefficiency. In general, these specification constraints can be expressed as follows.

$$F_{c,t}^{\text{out}} \leq \frac{Z_r}{\rho} \cdot \sum_{c \in C} (F_{c,r}^{\text{in}} + F_{\text{fresh water}}) \quad \forall r \in \{\text{WR}\} \quad (14)$$

$$F_{c,t}^{\text{out}} \leq \frac{Z_r}{\rho} \cdot \sum_{c \in C} (F_{c,r}^{\text{in}}) \quad \forall r \in \{\text{MT}, \text{TT}\} \quad (15)$$

in which Z_r is the upper bound for the amount of TDS, scale forming ions, or oil allowed for each water post-treatment alternative. Obviously, this constant can assume different values that depend on the component and wastewater-desired destination.

4.4. Logical Relationships. In the multistage superstructure shown in Figure 2, some water treatment technologies cannot be selected simultaneously. For instance, if the electrocoagulation is selected in stage 3, conventional coagulation followed by flocculation should not be selected at the same time. It would be expected that the optimal solution of the problem includes only one of those alternatives. The numerical performance of the model can be improved by explicitly adding logical relationships, which reflects the physical knowledge of the system and reduces the search space for the optimal solution.^{61,62} The following logical relationships are included in the model, in terms of Boolean variables and their re-formulation in the form of algebraic equations depending only on binary variables. See Raman and Grossmann⁶³ for a detailed description of how to systematically go from the logic to the algebraic equations.

In the second stage of the superstructure, the following logical relationship is used to decide between the existence of the hydrocyclone or a bypass:

$$Y_{\text{hy}} \vee Y_{\text{by},1} \rightarrow y_{\text{hy}} + y_{\text{by},1} = 1 \quad (16)$$

In the third stage, if the coagulation process is chosen, then the flocculation should be also selected to compose the WPS. However, only one option between coagulation and electrocoagulation processes can be selected in the superstructure. This choice can be ensured by the following logical relationships:

$$(Y_{\text{co}} \Rightarrow Y_{\text{flo}}) \vee Y_{\text{ec}} \rightarrow \begin{cases} y_{\text{co}} + y_{\text{ec}} = 1 \\ y_{\text{co}} - y_{\text{flo}} \leq 0 \end{cases} \quad (17)$$

In the fourth stage, the following three logic propositions must be defined. At most, one of the technologies can be selected from sedimentation, granular filtration and DAF. If coagulation is selected, then the removal factors for the technologies in the fourth stage are adjusted according to with the flocs presence in the outlet stream from previous (third) stage.

$$Y_{\text{sd}} \vee Y_{\text{gf}} \vee Y_{\text{df}} \rightarrow y_{\text{sd}} + y_{\text{gf}} + y_{\text{df}} = 1 \quad (18)$$

$$\begin{aligned} Y_{\text{co}} &\Leftrightarrow (Y_{\text{sd},m1} \vee Y_{\text{gf},m1} \vee Y_{\text{df},m1}) \rightarrow y_{\text{co}} \\ &= y_{\text{sd},m1} + y_{\text{gf},m1} + y_{\text{df},m1} \end{aligned} \quad (19)$$

$$\begin{aligned} Y_{\text{ec}} &\Leftrightarrow (Y_{\text{sd},m2} \vee Y_{\text{gf},m2} \vee Y_{\text{df},m2}) \rightarrow y_{\text{ec}} \\ &= y_{\text{sd},m2} + y_{\text{gf},m2} + y_{\text{df},m2} \end{aligned} \quad (20)$$

In the fifth stage, the softening technology and bypass are inclusive alternatives.

$$Y_{\text{sof}} \vee Y_{\text{by},2} \rightarrow y_{\text{sof}} + y_{\text{by},2} \geq 1 \quad (21)$$

In the last stage of the superstructure, the selection should be made between ultrafiltration, cartridge filtration, or bypass. This decision is guaranteed by the following logical relationship.

$$Y_{\text{uf}} \vee Y_{\text{cf}} \vee Y_{\text{by},3} \rightarrow y_{\text{uf}} + y_{\text{cf}} + y_{\text{by},3} = 1 \quad (22)$$

4.5. Objective Function. The total annualized cost (TAC) is composed of the capital investment in all equipment that compose the WPS and operational expenses. The TAC of the WPS is given by eq 23.

$$\text{TAC} = \sum_{t \in T} (\text{fac} \cdot C_t^{\text{capital}} + C_t^{\text{operational}}) \quad (23)$$

in which fac is the annualization factor as defined by Smith:⁶⁴

$$\text{fac} = \frac{i \cdot (1 + i)^h}{(1 + i)^h - 1} \quad (24)$$

in which i is the fractional interest rate per year and h is the horizon time. Correlations for the capital cost of some units (C_t^{capital}) have been extracted from the cost curves of the Environment Protection Agency (EPA) for water treatment plants,⁶⁵ revised and updated by McGivney and Kawamura.⁶⁶ These cost correlations account for the purchase cost, material, labor, pipes and valves, secondary equipment, and electrical

equipment and instrumentation. The capital costs of the hydrocyclone and electrocoagulation tank are calculated using the equations obtained from Turton.⁶⁷ Table 4 shows the correlations used for the estimation of capital costs. All cost correlations have been updated for the relevant year by the CEPCI index (Chemical Engineering Plant Cost Index).

The operational expenses ($C_t^{\text{operational}}$) include the cost of the chemicals added to the coagulation process ($C_{\text{coagulant}}$), operation cost of the electrocoagulation system ($C_{\text{electrodes}}$), cost of chemicals added in softening process (C_{chemical}), and cost of the freshwater needed in some cases ($C_{\text{freshwater}}$).

$$C_t^{\text{operational}} = C_{\text{coagulant}} \sum_{c \in C} \left(\frac{F_t}{\rho} \right) \cdot m \quad \forall t \in \{\text{co}\} \quad (25)$$

$$C_t^{\text{operational}} = C_{\text{electrodes}} \sum_{c \in C} \left(\frac{F_t}{\rho} \right) \cdot m \quad \forall t \in \{\text{ec}\} \quad (26)$$

$$C_t^{\text{operational}} = \sum_{j \in \text{chemicals}} \sum_{c \in C} x_j \cdot \left(\frac{F_t}{\rho} \right) \cdot C_j \cdot m \quad \forall t \in \{\text{sof}\} \quad (27)$$

$$C_t^{\text{operational}} = C_{\text{fresh water}} \cdot \left(\frac{F_{\text{fresh water}}}{\rho} \right) \cdot m \quad (28)$$

in which m is the number of working hours for the equipment in one year (8760 h). The chemical coagulation cost is considered to be equal to 3.5 US\$ m^{-3} . The electrocoagulation cost that includes electrode deterioration and energy consumption, is equal to 0.30 US\$ m^{-3} .⁶⁸ The cost of surface water from lakes and rivers strongly depends on the availability and the location. Typical freshwater costs are in a range 1.76–3.52 US\$ m^{-3} .¹⁵ The chemicals additives used in softening process are lime ($\text{Ca}(\text{OH})_2$) and soda (Na_2CO_3). The cost of these chemicals is 0.074 and 0.165 US\$ kg^{-1} , respectively. The costs have been obtained from the Independent Chemical Information Services (ICIS).⁶⁹

The mathematical model was implemented in GAMS software⁷⁰ (version 24.7.1). The solver BARON⁷¹ was used to optimize the problem. Note that, because BARON is a deterministic global optimization solver, global optimal solutions can be expected by the proposed approach. The model has been solved on a computer with a 3 GHz Intel Core Dual Processor and 4 GB RAM running Windows 7. The CPU time did not exceed some seconds to find the optimal solution. It should be highlighted that all constraints in this model are linear. The nonlinearities are only in the objective function, eqs 3 and 11. In general, the resulting problem has 569 continuous variables, 19 binary variables, and 605 equations (these numbers can slightly change if some constraints are added or removed from the model, which depends on of the wastewater-desired destination).

5. CASE STUDIES

Three cases studies are performed to evaluate the capabilities of the proposed model for the optimal WPS design, applied to the treatment of flowback water from shale gas production. As aforementioned, shale gas flowback water is usually recycled on-field, allowing its reuse in the hydraulic fracturing process of new wells. In some cases, however, the wastewater cannot be directly reused either because there are no more wells to drill (at least in a short period of time and the shale plays operate in

a regimen of gas production only) or because a simple pretreatment cannot ensure the physicochemical characteristics needed for the on-site reuse.

In this work, three case studies are carried out to cover different situations. The main difference between them relies on the wastewater destination according to the target: membrane or thermal-based technology to remove TDS or reuse in fracturing operations. The best water pretreatment alternatives are evaluated for each of these desired destinations, considering four different water compositions for each one. Table 1 shows the four different wastewater compositions selected to cover a wide range of water composition possibilities. As commented before, the flowback water composition can be extremely variable. In fact, it is dependent on several factors such as the characteristics of the shale rock formation, and the composition of the fracturing fluid used in the drilling process. Therefore, 12 different scenarios are initially considered to assess the applicability and flexibility of the proposed mathematical model for optimizing the WPS design. However, due to reverse osmosis limitations (a maximum of around 40 000 mg L^{-1} in TDS) in the second case study only one scenario is possible, which reduces the number of scenarios considered to nine. Figure 3 displays a graphical representation of the case studies.

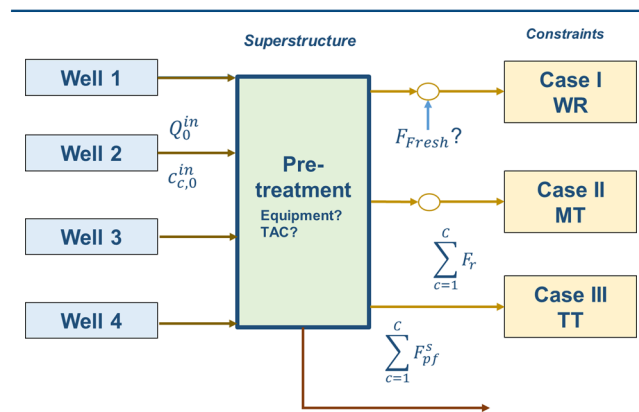

Figure 3. Graphical representation of the different case studies.

The WPS model is optimized to achieve different specifications according to the wastewater-desired destination, by the minimization of the total annualized cost that includes cost equipment and operational expenditures. Table 4 presents the correlations used for cost estimations. The specifications for each component for the desired composition in each case study are shown in Table 5. In all cases studies, the WPS is designed to have a treatment capacity of 25 $\text{m}^3 \text{h}^{-1}$ of shale gas flowback water. The interest rate per year (i) of 10% over a period (h) of 10 years is considered to estimate the annualized capital cost factor (fac). The main results obtained for the different case

Table 5. Constraints on Outlet Water Concentration for the Case Studies

case studies	limit concentration of component c , kg m^{-3}						
	TDS	TSS	Ca	Mg	Ba	Fe	oil
case I	50	0.05	2.5	2.5	2.5	0.035	0.025
case II	35	0.05	0.052	0.016	30.5	0.050	0.010
case III			0.026	0.008	15.25		0.010

Table 6. Optimal Results Obtained for the Different Scenarios

scenario	TAC (kUS\$ year ⁻¹)	C _{total} ^{capital} (kUS\$ year ⁻¹)	C _{operational} (kUS\$ year ⁻¹)	F _r (kg h ⁻¹)	F _{slud} (kg h ⁻¹)	F _{freshwater} (kg h ⁻¹)	CPU time (s)
1	139.35	40.88	98.57	25,219	274	76,780	3.22
2	382.97	41.31	341.66	25,323	177	2,334	3.19
3	95.31	38.17	57.13	25,411	89	31,120	7.06
4	95.11	38.15	56.96	25,491	9	0	0.44
5	121.84	41.96	79.87	25,485	15	0	1.11
6, 7, 8	These scenarios cannot be evaluated due to the constraint in the TDS concentration.						
9	1,838.66	42.26	1796.40	24,758	741	0	3.50
10	808.38	42.10	766.28	25,202	298	0	49.70
11	485.14	51.13	434.01	25,305	195	0	0.75
12	122.23	41.98	80.25	25,485	15	0	1.20

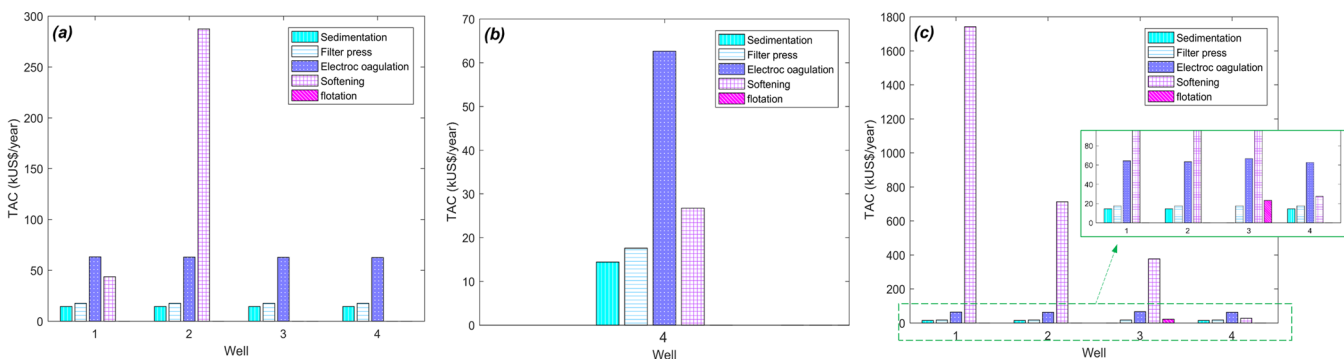

Figure 4. Effect of the inlet water composition on the total annualized cost (TAC): (a) case I - scenarios 1–4; (b) case II - scenarios 5–8; (c) case III - scenarios 9–12.

studies, which are presented in the following sections, are summarized in Table 6.

Case I: Pretreatment of Shale Gas Flowback Water Aiming Its Reuse. First, water reuse for drilling and fracking new wells is considered as the wastewater-desired destination. This target has a special interest in shale gas operations, due to its benefits that include reduction of freshwater consumption and, consequently, environmental impacts and transportation costs.

In this case, the optimal WPS configurations obtained by the proposed model are very similar for the water compositions of the four wells (scenarios 1–4). Thus, the water initially passes through the strainer filter to remove the largest particles. Afterward, electrocoagulation is used to remove solids, organics compounds, and some inorganics ions present in the flowback water. After that, the particles formed by electrocoagulation are eliminated by sedimentation. Finally, in the first and second scenarios, part of the flow passes through the softening process for further reduction of scale forming ions. Nevertheless, softening process is not needed for the last two scenarios. The TAC for the different scenarios is equal to 139.4, 383.0, 95.3, and 95.1 kUS\$ year⁻¹, respectively.

The contribution of softening process cost on the TAC is more significant as the presence of scaling ions becomes higher. In this case, small amount of external freshwater is necessary to satisfy the requirements for water reusing in hydraulic fracturing operations (Figure 4a). For instance, the inlet scaling ions concentration in the scenario 1 is higher than in scenario 2. However, the treated water from well 1 (scenario 1) must be mixed with 76 780 kg h⁻¹ of freshwater to ensure the required outlet water conditions. Note that it also allows diluting the concentration of the other contaminants.

In scenario 4 (well 4), the feedwater composition is a representative example for the case in which the concentration of each component is quite low. In this case, softening process is not necessary to achieve the acceptable limits on composition to reuse the water in others wells.

In general, the results obtained in this case study highlight that TAC is strongly dependent on the water inlet concentration. In this way, the water pretreatment becomes more expensive as higher concentrations of TDS and scaling ions are present in the inlet stream.

Case II: Pretreatment of Shale Gas Flowback Water Aiming To Remove TDS by Membrane Technologies. The pretreatment of shale gas flowback water for the membrane-based desalination as desired destination is more restrictive than the case I (Table 5). It is worth mentioning that the flowback water only can be treated by membrane technologies when the inlet composition of TDS is lower than 40 000 mg L⁻¹. Consequently, only the composition of well 4 (scenario 8) can be considered in this case.

The water pretreatment sequences obtained are very similar to those of the previous case study (case I). However, the TAC for the optimal WPS design is increased to 122 kUS\$ year⁻¹. It should be noted that the rise in the pretreatment costs is a consequence of the lower limit concentration imposed on the scaling forming ions, to allow wastewater post-treatment through membrane technologies. Figure 4b shows the cost analysis results obtained for this case study.

Case III: Pretreatment of Shale Gas Flowback Water Aiming To Remove TDS by Thermal Technologies. In case III, lower concentrations of calcium, barium, magnesium, and oil (Table 4) are imposed as composition restrictions to allow for thermal-based desalination technologies. These concentration limits should be considered to avoid particle

precipitation caused by the temperature changes in thermal desalination processes. In this case, except for scenario 11 (well 3), the same optimal WPS configurations of cases I and II are again obtained for the pretreatment of the three wells (scenarios 9, 10, and 12). The only difference between them is the operational expenses associated with the softening process, which is higher in this case due to the tight concentration constraints. In scenario 11, DAF is selected instead sedimentation.

In all scenarios, no freshwater is needed for decreasing the TDS contents, due to the ability of the thermal technologies to treat flowback water with more elevated salinities. The TAC in scenarios 9, 10, 11, and 12 are 1839, 808, 485, and 122 kUS\$ year⁻¹, respectively. Figure 4c displays the cost analysis results obtained for this case study.

6. CONCLUSIONS

Selection of the best alternatives for treatment of shale gas flowback water, allowing its reuse or recycle, is crucial to minimize freshwater usage, and consequently, related environmental impacts. However, the great variation in feedwater compositions, concentration constraints for different wastewater-desired destinations, and regulation, make it difficult to choose the optimal WPS configuration.

A new mathematical programming model is introduced to optimize the WPS design, considering different alternatives for the pretreatment of shale gas flowback water. The mathematical model is formulated using GDP and optimized under GAMS as a MINLP problem, by the minimization of the total annualized cost of the system. For this purpose, a multistage superstructure is proposed to be composed of several stages with distinct water pretreatment technologies. The selection of the equipment in each superstructure stage was carried out on a stage-by-stage heuristic basis, to guarantee the workability of each upcoming stage. Hence, the superstructure for the optimal system design allows identifying the most cost-effective process to reduce specific contaminants, according to the feedwater composition and wastewater-desired destination (i.e., water reuse or water recycling).

Because each wastewater-desired destination requires specific target composition constraints, three case studies are performed to assess the applicability of the proposed approach. Thus, four distinct feedwater compositions covering a large range of flowback water concentrations are evaluated for three different target conditions: reuse, post-treatment by membrane-based technologies, and post-treatment by thermal-based technologies.

The optimal WPS configurations obtained for the water treatment are very similar, or even equal, for the different case studies. The main differences between them are due to removing scaling forming ions, and the need for diluting the outlet water flow to achieve the required TDS concentration. However, the total annualized cost for these scenarios is as higher as more restrictive is the target water destination.

Note that the optimal WPS configurations obtained for the four wells treated for allowing water reuse in case I correspond to the lowest total annualized costs. This is again a consequence of the weaker restrictions imposed on the concentration limits for the water reuse in other wells.

■ ASSOCIATED CONTENT

📄 Supporting Information

The Supporting Information is available free of charge on the ACS Publications website at DOI: 10.1021/acs.iecr.6b04016.

GAMS model implementation (TXT)

■ AUTHOR INFORMATION

Corresponding Author

*V. C. Onishi. Phone: +34 965903400. E-mail addresses: viviani.onishi@ua.es, viviani.onishi@pq.cnpq.br.

ORCID

Viviani C. Onishi: 0000-0002-7894-1092

Notes

The authors declare no competing financial interest.

■ ACKNOWLEDGMENTS

This project has received funding from the European Union's Horizon 2020 Research and Innovation Programme under grant agreement No. 640979.

■ NOMENCLATURE

Roman Letters

<i>A</i>	area, m ²
<i>c</i>	components, concentrations in kg m ⁻³
<i>C</i> ^{capital}	capital cost, kUS\$ year ⁻¹
<i>C</i> ^{operational}	operational cost, kUS\$ year ⁻¹
<i>C</i> _{chemical}	cost of chemical added in coagulation, US\$ kg ⁻¹
<i>C</i> _{electrodes}	cost of the electrodes needed in electrocoagulation, US\$ kg ⁻¹
<i>C</i> _{freshwater}	cost of freshwater, US\$ m ⁻³
<i>D</i> _{hy}	diameter of hydrocyclone, m
<i>DT</i>	detention time, h
<i>F</i>	mass flow rate, kg h ⁻¹
<i>fac</i>	annualized capital cost factor
<i>F</i> ^{feed_water}	fresh water mass flow rate, kg h ⁻¹
<i>i</i>	fractional interest rate per year
<i>LR</i>	loading rate, m h ⁻¹
<i>m</i>	working time in one year, h
<i>h</i>	horizon time, year
<i>TAC</i>	total annualized cost, kUS\$ year ⁻¹
<i>V</i>	volume, m ³
<i>y</i>	binary variable
<i>Y</i>	Boolean variable

Subscripts

<i>b</i>	bypass
<i>c</i>	component
<i>cf</i>	cartridge filter
<i>co</i>	coagulation
<i>df</i>	dissolved air flotation
<i>ec</i>	electrocoagulation
<i>flo</i>	flocculation
<i>gf</i>	granular filter
<i>hy</i>	hydrocyclone
<i>pf</i>	press filter
<i>r</i>	post-treatment alternatives
<i>sd</i>	sedimentation
<i>sf</i>	strainer filter
<i>t</i>	number of pretreatment technologies
<i>uf</i>	ultrafiltration
<i>WR</i>	water reuse
<i>MT</i>	membrane treatment

TT thermal technology

Superscript

in inlet
out outlet
slud sludge

Acronyms

CEPCI chemical engineering plant cost index
DAF dissolved air flotation
EPA environment protection agency
GAMS general algebraic modeling system
GDP generalized disjunctive programming
LCA life cycle assessment
MD membrane distillation
MEE–MVR multiple-effect evaporation with/without mechanical vapor recompression
MINLP mixed-integer linear programming
MSF multistage flash
NORM normally occurring radioactive materials
PSE process systems engineering
RO reverse osmosis
TAC total annual cost
TDS total dissolved solids
TOC total organic carbon
TSS total suspended solids
WPS water pretreatment system
ZLD zero liquid discharge

Greek Letters

μ viscosity, kg (m s)^{-1}
 α removal factor
 ρ density, kg m^{-3}
 τ dynamic viscosity, kg (m s)^{-1}

REFERENCES

- (1) Rahm, B. G.; Riha, S. J. Toward Strategic Management of Shale Gas Development: Regional, Collective Impacts on Water Resources. *Environ. Sci. Policy* **2012**, *17*, 12.
- (2) Cooper, J.; Stamford, L.; Azapagic, A. Shale Gas: A Review of the Economic, Environmental, and Social Sustainability. *Energy Technol.* **2016**, *4* (7), 772.
- (3) Wang, Q.; Li, R. Natural Gas from Shale Formation: A Research Profile. *Renewable Sustainable Energy Rev.* **2016**, *57*, 1.
- (4) Blythe, K.; Jeffries, R.; Travers, M. An International Perspective of Challenges and Constraints in Shale Gas Extraction. In *Environmental and Health Issues in Unconventional Oil and Gas Development*; Elsevier, 2016; pp 225–248.
- (5) *Annual Energy Outlook*; US Energy Information Administration: Washington, DC, 2013; [https://www.eia.gov/outlooks/aeo/pdf/0383\(2013\).pdf](https://www.eia.gov/outlooks/aeo/pdf/0383(2013).pdf).
- (6) Xiong, B.; Zydney, A. L.; Kumar, M. Fouling of Microfiltration Membranes by Flowback and Produced Waters from the Marcellus Shale Gas Play. *Water Res.* **2016**, *99*, 162.
- (7) Gao, J.; You, F.; Gao, J.; You, F. Shale Gas Supply Chain Design and Operations Toward Better Economic and Life Cycle Environmental Performance: MINLP Model and Global Optimization Algorithm. *ACS Sustainable Chem. Eng.* **2015**, *3* (7), 1282.
- (8) Clark, C. E.; Horner, R. M.; Harto, C. B. Life Cycle Water Consumption for Shale Gas and Conventional Natural Gas Supporting Information. *Environ. Sci. Technol.* **2013**, *47* (20), 11829.
- (9) Shaffer, D. L.; Arias Chavez, L. H.; Ben-Sasson, M.; Romero-Vargas Castrillón, S.; Yip, N. Y.; Elimelech, M. Desalination and Reuse of High-Salinity Shale Gas Produced Water: Drivers, Technologies, and Future Directions. *Environ. Sci. Technol.* **2013**, *47* (17), 9569.
- (10) Takahashi, S.; Kovscek, A. R. Spontaneous Counter Current Imbibition and Forced Displacement Characteristics of Low-Permeability, Siliceous Shale Rocks. *J. Pet. Sci. Eng.* **2010**, *71* (1–2), 47.
- (11) Chen, H.; Carter, K. E. Water Usage for Natural Gas Production through Hydraulic Fracturing in the United States from 2008 to 2014. *J. Environ. Manage.* **2016**, *170*, 152.
- (12) Chen, G.; Wang, Z.; Nghiem, L. D.; Li, X. M.; Xie, M.; Zhao, B.; Zhang, M.; Song, J.; He, T. Treatment of Shale Gas Drilling Flowback Fluids (SGDFs) by Forward Osmosis: Membrane Fouling and Mitigation. *Desalination* **2015**, *366*, 113.
- (13) Vengosh, A.; Warner, N.; Jackson, R.; Darrah, T. The Effects of Shale Gas Exploration and Hydraulic Fracturing on the Quality of Water Resources in the United States. *Procedia Earth Planet. Sci.* **2013**, *7*, 863.
- (14) Ghanbari, E.; Dehghanpour, H. The Fate of Fracturing Water: A Field and Simulation Study. *Fuel* **2016**, *163*, 282.
- (15) Yang, L.; Grossmann, I. E.; Manno, J. Optimization Models for Shale Gas Water Management. *AIChE J.* **2014**, *60* (10), 3490.
- (16) Jacquet, J. B. Review of Risks to Communities from Shale Energy Development. *Environ. Sci. Technol.* **2014**, *48* (15), 8321.
- (17) Hammond, G. P.; O'Grady, Á. Indicative Energy Technology Assessment of UK Shale Gas Extraction. *Appl. Energy* **2017**, *185*, 1907.
- (18) Prpich, G.; Coulon, F.; Anthony, E. J. Review of the Scientific Evidence to Support Environmental Risk Assessment of Shale Gas Development in the UK. *Sci. Total Environ.* **2016**, *563–564*, 731.
- (19) Acharya, H. R.; Henderson, C.; Matis, H.; Kommepalli, H.; Moore, B.; Wang, H. Cost Effective Recovery of Low-TDS Frac Flowback Water for Re-Use. *Glob. Res.* **2011**, *June*, 1.
- (20) Lutz, B. D.; Lewis, A. N.; Doyle, M. W. Generation, Transport, and Disposal of Wastewater Associated with Marcellus Shale Gas Development. *Water Resour. Res.* **2013**, *49* (2), 647.
- (21) Gregory, K. B.; Vidic, R. D.; Dzombak, D. A. Water Management Challenges Associated with the Production of Shale Gas by Hydraulic Fracturing. *Elements* **2011**, *7* (3), 181.
- (22) Ground Water Protection Council, ALL Consulting. *Modern Shale Gas Development in the United States: A Primer*; United States Department of Energy, Office of Fossil Energy: Washington, DC, 2009; p 96.
- (23) Balaba, R. S.; Smart, R. B. Total Arsenic and Selenium Analysis in Marcellus Shale, High-Salinity Water, and Hydrofracture Flowback Wastewater. *Chemosphere* **2012**, *89* (11), 1437.
- (24) Kidder, M.; Palmgren, T.; Ovalle, A.; Kapila, M. Treatment Options for Reuse of Frac Flowback and Produced Water from Shale. *World Oil* **2011**, *232* (7), 95.
- (25) Horner, P.; Anderson, J. a.; Thompson, M. Mobile Clarification for Re-Use of Unconventional Oil and Gas Produced Water to Reduce Costs and Minimize Environmental Footprint. In *Unconventional Resources Technology Conference, Denver, Colorado, 12–14 August 2013*; Society of Exploration Geophysicists, American Association of Petroleum Geologists, Society of Petroleum Engineers: Tulsa, OK, 2013; pp 2098–2107.
- (26) Hayes, T.; Severin, B. F. Barnett and Appalachian Shale Water Management and Reuse Technologies. *Project report by Gas Technology Institute for Research Partnership to Secure Energy for America (RPSEA)*; RPSEA: Houston, TX, 2012; pp 1–125.
- (27) Camarillo, M. K.; Domen, J. K.; Stringfellow, W. T. Physical-Chemical Evaluation of Hydraulic Fracturing Chemicals in the Context of Produced Water Treatment. *J. Environ. Manage.* **2016**, *183*, 164.
- (28) Camacho, L.; Dumée, L.; Zhang, J.; Li, J.; Duke, M.; Gomez, J.; Gray, S. Advances in Membrane Distillation for Water Desalination and Purification Applications. *Water* **2013**, *5* (1), 94.
- (29) Keister, T.; Sleigh, J.; Briody, M. Sequential Precipitation - Fractional Crystallization Treatment of Marcellus Shale Flowback and Production Wastewaters. In *International Water Conference IWC 12-72*, **2012**.
- (30) Estrada, J. M.; Bhamidimarri, R. A Review of the Issues and Treatment Options for Wastewater from Shale Gas Extraction by Hydraulic Fracturing. *Fuel* **2016**, *182*, 292.
- (31) Kaden, D.; Rose, T. *Environmental and Health Issues in Unconventional Oil and Gas Development*; Elsevier: Amsterdam, 2016.

- (32) Onishi, V. C.; Carrero-Parreño, A.; Reyes-Labarta, J. A.; Fraga, E. S.; Caballero, J. A. Desalination of Shale Gas Produced Water: A Rigorous Design Approach for Zero-Liquid Discharge Evaporation Systems. *J. Cleaner Prod.* **2017**, *140*, 1399.
- (33) Onishi, V. C.; Carrero-Parreño, A.; Reyes-Labarta, J. A.; Ruiz-Femenia, R.; Salcedo-Díaz, R.; Fraga, E. S.; Caballero, J. A. Shale Gas Flowback Water Desalination: Single vs Multiple-Effect Evaporation with Vapor Recompression Cycle and Thermal Integration. *Desalination* **2017**, *404* (C), 230.
- (34) Michel, M. M.; Reczek, L.; Granops, M.; Rudnicki, P.; Piech, A. Pretreatment and Desalination of Flowback Water from the Hydraulic Fracturing. *Desalin. Water Treat.* **2016**, *57* (22), 10222.
- (35) Kim, J.; Kwon, H.; Lee, S.; Lee, S.; Hong, S. Membrane Distillation (MD) Integrated with Crystallization (MDC) for Shale Gas Produced Water (SGPW) Treatment. *Desalination* **2017**, *403*, 172.
- (36) Warsinger, D. M.; Swaminathan, J.; Guillen-Burrieza, E.; Arafat, H. A.; Lienhard V, J. H. Scaling and Fouling in Membrane Distillation for Desalination Applications: A Review. *Desalination* **2015**, *356*, 294.
- (37) Wang, P.; Chung, T.-S. Recent Advances in Membrane Distillation Processes: Membrane Development, Configuration Design and Application Exploring. *J. Membr. Sci.* **2015**, *474*, 39.
- (38) Cho, H.; Choi, Y.; Lee, S.; Sohn, J.; Koo, J. Membrane Distillation of High Salinity Wastewater from Shale Gas Extraction: Effect of Antiscalants. *Desalin. Water Treat.* **2016**, *57* (55), 26718.
- (39) Beery, M.; Wozny, G.; Repke, J.-U. Sustainable Design of Different Seawater Reverse Osmosis Desalination Pretreatment Processes. *Comput.-Aided Chem. Eng.* **2010**, *28*, 1069–1074.
- (40) Beery, M.; Hortop, A.; Wozny, G.; Knops, F.; Repke, J.-U. Carbon Footprint of Seawater Reverse Osmosis Desalination Pre-Treatment: Initial Results from a New Computational Tool. *Desalin. Water Treat.* **2011**, *31* (1–3), 164.
- (41) Beery, M.; Wozny, G.; Repke, J. Computer-Aided Model-Based SWRO Pretreatment Process Design: A Multidisciplinary Approach. *IDA J.* **2012**, 18–25.
- (42) Beery, M.; Lee, J. J.; Kim, J. H.; Repke, J.-U. Ripening of Granular Media Filters for Pretreatment of Seawater in Membrane Desalination. *Desalin. Water Treat.* **2010**, *15* (1–3), 29.
- (43) Almond, S.; Clancy, S. A.; Davies, R. J.; Worrall, F. The Flux of Radionuclides in Flowback Fluid from Shale Gas Exploitation. *Environ. Sci. Pollut. Res.* **2014**, *21* (21), 12316.
- (44) Silva, J. M.; Matis, H.; Kostedt, W. L.; Watkins, L. Produced Water Pretreatment for Water Recovery and Salt Production. http://www.rpsea.org/media/files/project/18621900/08122-36-FR-Pretreatment_Water_Mgt_Frac_Water_Reuse_Salt-01-26-12.pdf.
- (45) Kraipech, W.; Chen, W.; Dyakowski, T.; Nowakowski, A. The Performance of the Empirical Models on Industrial Hydrocyclone Design. *Int. J. Miner. Process.* **2006**, *80* (2–4), 100.
- (46) Emamjomeh, M. M.; Sivakumar, M. Review of Pollutants Removed by Electrocoagulation and Electrocoagulation/flotation Processes. *J. Environ. Manage.* **2009**, *90* (5), 1663.
- (47) Geraldino, H. C. L.; Simionato, J. I.; Freitas, T. K. F.; de, S.; Garcia, J. C.; Carvalho Júnior, O.; De Correr, C. J. Efficiency and Operating Cost of Electrocoagulation System Applied to the Treatment of Dairy Industry Wastewater. *Acta Sci., Technol.* **2015**, *37* (3), 401.
- (48) Crittenden, J. C.; Trussell, R. R.; Hand, D. W.; Howe, K. J.; Tchobanoglous, G. *Water Treatment Principles and Design*, 3rd ed.; John Wiley and Sons: Atlanta, GA, 2012.
- (49) Loganathan, K.; Chelme-Ayala, P.; Gamal El-Din, M. Pilot-Scale Study on the Treatment of Basal Aquifer Water Using Ultrafiltration, Reverse Osmosis and Evaporation/crystallization to Achieve Zero-Liquid Discharge. *J. Environ. Manage.* **2016**, *165*, 213.
- (50) He, C.; Wang, X.; Liu, W.; Barbot, E.; Vidic, R. D. Microfiltration in Recycling of Marcellus Shale Flowback Water: Solids Removal and Potential Fouling of Polymeric Microfiltration Membranes. *J. Membr. Sci.* **2014**, *462*, 88.
- (51) Cluff, M. A.; Hartsock, A.; MacRae, J. D.; Carter, K.; Mouser, P. J. Temporal Changes in Microbial Ecology and Geochemistry in Produced Water from Hydraulically Fractured Marcellus Shale Gas Wells. *Environ. Sci. Technol.* **2014**, *48* (11), 6508.
- (52) Edzwald, J. K. Dissolved Air Flotation and Me. *Water Res.* **2010**, *44* (7), 2077.
- (53) Wilson, J. R.; Mahank, T. A. Hydrocyclone Separation for the Remediation of Contaminated Sediment. *ASCE North Central Section Conference* **2016**, 1–8.
- (54) Fakhru'l-Razi, A.; Pendashteh, A.; Abdullah, L. C.; Biak, D. R. A.; Madaeni, S. S.; Abidin, Z. Z. Review of Technologies for Oil and Gas Produced Water Treatment. *J. Hazard. Mater.* **2009**, *170* (2–3), 530.
- (55) Houcine, M. Solution for Heavy Metals Decontamination in Produced Water/case Study in Southern Tunisia. *International Conference on Health, Safety and Environment in Oil and Gas Exploration and Production*, Kuala Lumpur, Malaysia, 20–22 March, **2002.10.2118/74003-MS**
- (56) Bilstad, T.; Espedal, E. Membrane Separation of Produced Water. *Water Sci. Technol.* **1996**, *34* (9), 239.
- (57) Vecchiotti, A.; Lee, S.; Grossmann, I. E. Modelling of Discrete/Continuous Optimization Problems: Characterization and Formulations of Disjunctions and Their Relaxations. *Comput. Chem. Eng.* **2003**, *27*, 433.
- (58) Trespalacios, F.; Grossmann, I. E. Review of Mixed-Integer Nonlinear and Generalized Disjunctive Programming Methods. *Chem. Ing. Tech.* **2014**, *86* (7), 991.
- (59) Ulucan, K.; Kabuk, H. A.; Ilhan, F.; Kurt, U. Electrocoagulation Process Application in Bilge Water Treatment Using Response Surface Methodology. *Int. J. Electrochem. Sci.* **2014**, *9* (5), 2316.
- (60) Vieira, L. G. M.; Barbosa, E. A.; Damasceno, J. J. R.; Barrozo, M. A. S. Performance Analysis and Design of Filtering Hydrocyclones. *Braz. J. Chem. Eng.* **2005**, *22* (1), 143.
- (61) Raman, R.; Grossmann, I. E. Relation between MILP Modelling and Logical Inference for Chemical Process Synthesis. *Comput. Chem. Eng.* **1991**, *15* (2), 73.
- (62) Biegler, L.; Grossmann, I.; Westerberg, A. *Systematic Methods of Chemical Process Design*; Prentice Hall: Englewood Cliffs, NJ, 1999.
- (63) Raman, R.; Grossmann, I. E. Modelling and Computational Techniques for Logic Based Integer Programming. *Comput. Chem. Eng.* **1994**, *18* (7), 563.
- (64) Smith, R. M. *Chemical Process Design and Integration*; John Wiley and Sons: New York, 2005.
- (65) Gumerman, R.; Culp, R.; Hansen, S. *Estimating Water Treatment Costs*; Environmental Protection Agency: Washington, DC, 1979.
- (66) McGivney, W.; Kawamura, S. *Cost Estimating Manual for Water Treatment Facilities*; John Wiley & Sons, Inc.: Hoboken, NJ, 2008.
- (67) Turton, R.; Bailie, R. C.; Whiting, W. B.; Shaiwitz, J. A.; Bhattacharyya, D. *Analysis, Synthesis, and Design of Chemical Processes*, fourth ed.; Prentice Hall: Englewood Cliffs, NJ, 2012.
- (68) Powell Water Systems, I. Electrocoagulation Vs. Chemical Coagulation <http://powellwater.com/electrocoagulation-vs-chemical-coagulation/>.
- (69) ICIS Trusted market intelligence for the global chemical, energy and fertilizer industries. Indicative Chemical Prices. Available at.
- (70) Rosenthal, R. E. *GAMS — A User's S Guide*; GAMS Development Corporation: Washington, DC, 2016.
- (71) Tawarmalani, M.; Sahinidis, N. V. A Polyhedral Branch-and-Cut Approach to Global Optimization. *Math. Program.* **2005**, *103* (2), 225.
- (72) Hutcherson, J. R. A Comparison of Electrocoagulation and Chemical Coagulation Treatment Effectiveness on Frac Flowback and Produced Water. *Masters Thesis*, Colorado State University, 2015.
- (73) Beery, M.; Jekel, M. Novel Sustainable Concepts in Process Design and Assessment of Seawater Reverse Osmosis Pre-Treatment. *Doctoral Dissertation*, TU Berlin, 2013.
- (74) Cogan, J. D. The Removal of Barium, Strontium, Calcium and Magnesium from Hydraulic Fracturing Produced Water Using Precipitation with Traditional and Alternative Reactant Feedstocks. *Masters Thesis*, Voinovich School of Leadership & Public Affairs, Ohio University, 2016.