

## **A review of thermal management for Li-ion batteries: Prospects, challenges, and issues**

Shahjalal, Mohammad ; Shams, Tamanna ; Islam, Md. Emtiajul ; Alam, Wasif ; Modak, Mrinmoy ; Hossain, Sadat Bin ; Ramadesigan, Venkatasailanathan ; Ahmed, Md. Rishad ; Ahmed, Hafiz; Iqbal, Atif

**Journal of Energy Storage**

DOI:  
[10.1016/j.est.2021.102518](https://doi.org/10.1016/j.est.2021.102518)

Published: 01/07/2021

Peer reviewed version

[Cyswllt i'r cyhoeddiad / Link to publication](#)

*Dyfyniad o'r fersiwn a gyhoeddwyd / Citation for published version (APA):*  
Shahjalal, M., Shams, T., Islam, M. E., Alam, W., Modak, M., Hossain, S. B., Ramadesigan, V., Ahmed, M. R., Ahmed, H., & Iqbal, A. (2021). A review of thermal management for Li-ion batteries: Prospects, challenges, and issues. *Journal of Energy Storage*, 39, [102518].  
<https://doi.org/10.1016/j.est.2021.102518>

### **Hawliau Cyffredinol / General rights**

Copyright and moral rights for the publications made accessible in the public portal are retained by the authors and/or other copyright owners and it is a condition of accessing publications that users recognise and abide by the legal requirements associated with these rights.

- Users may download and print one copy of any publication from the public portal for the purpose of private study or research.
- You may not further distribute the material or use it for any profit-making activity or commercial gain
- You may freely distribute the URL identifying the publication in the public portal ?

### **Take down policy**

If you believe that this document breaches copyright please contact us providing details, and we will remove access to the work immediately and investigate your claim.

# A Review of Thermal Management for Li-ion Batteries: Prospects, Challenges, and Issues

Mohammad Shahjalal<sup>a</sup>, Tamanna Shams<sup>b</sup>, Md.Emtiajul Islam<sup>c</sup>, Wasif Alam<sup>c</sup>, Mrinmoy Modak<sup>c</sup>, Sadat Bin Hossain<sup>c</sup>, Venkatasailanathan Ramadesigan<sup>d</sup>, Md. Rishad Ahmed<sup>e</sup>, Hafiz Ahmed<sup>f</sup>, and Atif Iqbal<sup>g</sup>

<sup>a</sup>WMG, University of Warwick, Coventry CV4 7AL, United Kingdom

<sup>b</sup>University of Wolverhampton, Wulfruna St, Wolverhampton WV1 1LY, United Kingdom

<sup>c</sup>Chittagong University of Engineering and Technology, CUET-4349, Bangladesh

<sup>d</sup> Indian Institute of Technology Bombay, India

<sup>e</sup>University of Nottingham, University Park Campus, Nottingham NG7 2RD, United Kingdom

<sup>f</sup>Birmingham City University, 15 Bartholomew Row, Birmingham B5 5JU, United Kingdom

<sup>g</sup>Qatar University, University Street, Doha, Qatar

**Abstract**— Li-ion batteries are essential component in the current generation of electric vehicles. However, further pushing electric vehicles are concerned with battery life. Since the temperature dictates battery lifetime, it is crucial to manage the heat and keep the temperature at an acceptable range within the battery pack. The benefit of a cooling system is to prevent the premature degradation of battery life. This paper provides a critical review of the so far thermal management strategy dealing with temperature within the cells, module, and packs. This paper reviews the advantages and disadvantages of state of the art (traditional) thermal cooling system. In this paper, we have reviewed separately cell, module, and pack level cooling system. The battery thermal modeling techniques and cooling system design challenges are also reviewed. This paper also reviews the future cooling system for future vehicles with rising fast charge rate and these techniques can improve the limitations of the traditional cooling system. This paper also suggests the best suitable and economically viable technology for the upcoming EVs issues.

**Keywords**— Thermal management of battery, Li-ion battery, air cooling, cooling with liquid, vapor cooling, next-generation battery.

## 1. INTRODUCTION

THE transportation sector is now more dependable on electricity than the other fuel operation due to the emerging energy and environmental issues. Fossil fuel operated vehicle is not environment friendly as they emit greenhouse gases such as CO<sub>2</sub> [1]. Li-ion batteries are the best power source for electric vehicle (EV) due to comparatively higher energy density and power density, higher discharge of voltage, higher gravimetric also volumetric energy density with lower self-discharge rate during calendar-life than other existing battery technologies [2, 3]. However, Li-ion batteries also generate heat due to the charging/discharging process by electrochemical reaction. If the heat is not managed, this can overheat the battery or lead to possible thermal runaway due to exothermic reaction and temperature rise above irreversible incidents [4, 5]. Consequently, battery life will be compromised which is not favorable to the EV owner. Hence, battery thermal management is not only essential to maintain a healthy operating range but also important to achieve uniformity on temperature distribution for a longer lifetime of a battery pack.

Heat generation is inevitable inside the battery and battery pack. The generated heat will create a temperature rise and thus lead to a large temperature difference inside the battery pack. Consequently, it will affect the battery health. If the heat generation left untreated, it can lead to not only capacity fade but also a thermal runaway with instability within the packs. Besides, severe operating conditions like extreme fast charging and cold climate can accelerate the aging of the battery. The aged battery will generate more heat. The permissible temperature for the battery pack is 6°C. Therefore, effective thermal management for a lithium-ion battery is fundamental to extend its lifetime.

Several thermal management strategies already exist in the literature. These include active cooling, passive cooling, air-cooling with forced convection by air and liquids and solid-liquid phase change materials (PCM), heat pipe cooling, and thermoelectric

element cooling.

This paper critically reviews the generation of heat in the battery, describes the state-of-the-art cooling technology at the cell level, module level, pack level, and battery thermal management strategies, cooling system design challenges. This paper describes 1D, 2D, and 3D modeling of the cooling system, battery degradation challenges, and future cooling strategy. Lastly, this paper concludes the current research challenges and outlines future research direction towards effective battery thermal management.

## 2. THERMAL ISSUES

### 2.1. Heat Generation

Li-ion batteries are rechargeable batteries and their operating principle is based on electrochemical redox reactions. Heat generation inside the battery happens due to the exothermic reactions as well as the ohmic loss in the solid and electrolyte phases due to charge transport resulting in temperature rise in the cell. The heating of the cells affect neighboring cells via thermal coupling in the module. The heated module also affect neighboring module and thus distributes heat in the pack. This temperature rise is also responsible for entropy change, which affects battery performance. An increase in the rate of charge or discharge also causes heat energy generation in the battery. The high level of heat generation is detrimental for the battery as well as the passengers in terms of safety and reliability.

Generally, in cylindrical type Li-ion batteries the heat energy generation is observed to be maximum at the center of the vertical axis of the cylinder, and also heat spreading occurs on the surface. Typical temperature distribution on the cylindrical cell is shown in **Fig.1**[6]. In highly interconnected battery packs cells are prone to generate heat and thermal coupling is strong due to their proximity. Therefore, it is important to control temperature rise in the cell and achieve more uniform temperature distribution across the module and pack for extending battery lifetime. If the temperature issues left untreated, thermal runaway could occur which can lead to explosion or fire causing safety hazards. . In **2018**, thermal runaway causes in lithium-ion batteries was investigated by Feng et al.[7]. The temperature rise is very dangerous for safety-critical operation. The heat energy generation equation can be described by[8]

$$Q = -I \left( T \frac{dE}{dT} \right) + I(E - V) \dots\dots\dots (1)$$

Where,

$I$  is the current in A

$I$  is positive at discharge and vice versa

$T$  is the temperature in K.

$\frac{dE}{dT}$  is the temperature coefficient also  $E$  is the voltage(open circuit).

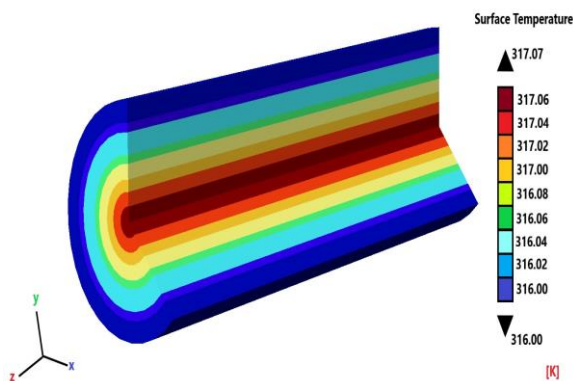

**Fig. 1.** Heat generation at center and surface in cylindrical battery[6]

### 2.2. Benefits of cooling technology

Lithium-ion batteries have much temperature sensitivity. The optimum range of operating temperature for battery operation is close to about 15°C to 35°C [9]. However, due to high current loading conditions such as fast charging or accelerations, the transient battery can experience unacceptable temperature rise. Lithium-ion batteries are usually arranged in the battery pack by series-parallel configuration. The interconnections of cells contribute to increased resistance which appears as an uneven dynamic load. As a result, batteries not only experience non-uniform heat generation rates due to the positioning of cells in the battery pack but also have temperature non-uniformity at the charging and discharging period. So the temperature should be controlled to maintain the temperature at an acceptable range. To achieve the temperature uniformity at an acceptable range, many conventional Battery

Thermal Management (BTM) systems have already been developed. These different systems have different advantages and disadvantages. They exploit various cooling strategies. These include air cooling, liquid cooling, phase change materials (PCM) cooling, and vapor compression cooling also have mixed cooling.

By applying appropriate cooling Battery Thermal Management (BTM) system keeps the battery temperature at an acceptable range. So, at a higher discharging rate the temperature inside the battery of the Battery Electric Vehicles (BEV) can be maintained within a safe thermal limit. . The Liquid cooling system seems more promising in extracting heat more than air cooling. PCM has high latent heat however, it has low thermal conductivity. The heat of the battery is usually eliminated with the conduction process, convection, and also by radiation into the outside area by those BTM systems [10]. The lifetime, mileage, efficiency, all are heavily dependent on temperature. If the battery temperature can be kept at an optimum range by applying those BTM systems, the lifetime, efficiency, mileage will be extended. In the future, there will come more high-level vehicles. Thus temperature control is very important, and this will bring more challenges to the existing BTM system. The efficiency of Li-ion batteries depends on the operating temperature. It is shown in Fig. 2 [11]. It is worth noting that the maximum power or efficiency occurred at an optimum range of temperature starting from 15°C to 35°C and outside of this range the battery degradation starts to happen. To ensure high efficiency and deliver optimum battery power BTM systems must control the temperature.

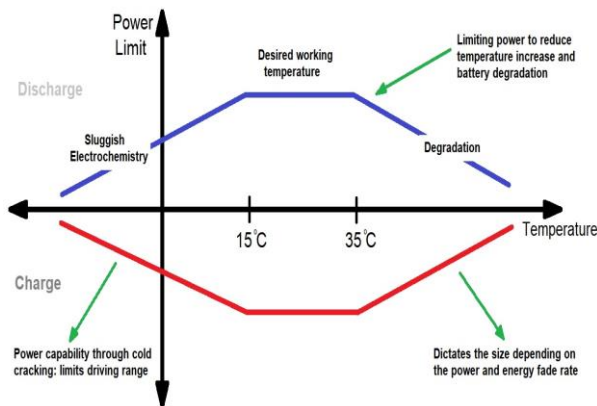

**Fig. 2.** Battery operating range and efficiency [11]

### 2.3. State-of-the-art cooling technology

Cooling strategy is highly essential for EV to drive the battery in optimal condition. Overheating is not only responsible for decreasing battery performance but also for decreasing the lifetime of the battery. To drive the battery in optimal condition, BTM has to meet the following criteria [12].

- (i) BMS should maintain the optimum temperature for cells and reject heat in hot climate/ absorb heat in cold weather.
- (ii) Temperature variation should be small between cells and modules and that of different modules.
- (iv) System should be compact, lightweight, reliable, and low cost.
- (v) There should be a ventilation system if hazardous gases generate potentially from a battery.

The cooling system can be categorized in different ways. Considering medium the cooling system can be classified in [13]

1. Air cooling
2. Liquid cooling
3. PCM cooling

Based on the thermal cycle the cooling system can be divided into two groups [13]

1. BTMS with vapor compression cycle(VCC)
  - I. Cabin air cooling
  - II. Secondary loop liquid cooling
  - III. Direct refrigerant two-phase cooling
2. BTMS without VCC

- I. PCM cooling
- II. Heat pipe cooling
- III. Thermo-electric element cooling

According to the power consumption cooling system can be classified into two groups. These include an active cooling system and a passive cooling system. Battery performance can also be enhanced by combining two cooling systems. Each system has a strategy for cooling.

Here we will discuss the traditional battery thermal system for cooling [14]

### 2.3.1. Air Cooling

The air cooling system is commonly used in EV because of its simple operating system. It also requires less equipment. By the flow of cold air in the battery pack, the system is cooled. Based on power consumption there is active air cooling which uses pre-conditioned air from the air conditioner and passive air cooling which uses ambient air [15]. Passive air cooling has less efficiency than active air cooling.[4]. The active cooling and passive cooling configuration are shown in **Fig.3.** [11].

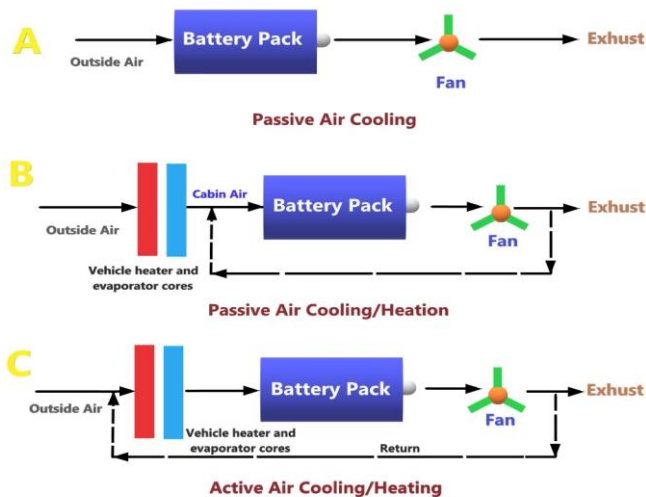

**Fig. 3.** Active cooling and passive cooling[11].

H. Sun *et al.* [16] experimented reciprocating air concept (illustrated in **Fig.4.** [16]), in this experiment an air compressor produces the airflow measured by a regulated flow meter. A thermo-regulated bath with a circulator, combined with a heat exchanger, controls air inlet temperature. The result shows that the cooling reduces 72% heat (4 °C) and decreases maximum cell temperature by 1.5 °C in a time interval of 120 seconds.[4]. The cooling efficiency can further be increased by choosing the right flow pattern (Z type, U type).

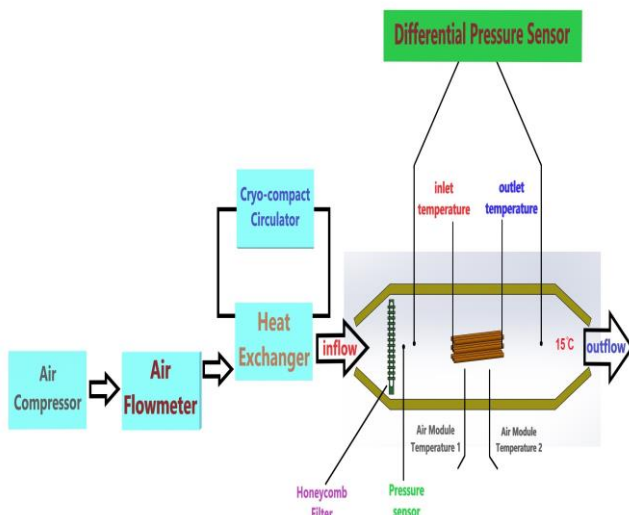

**Fig. 4.** Experimental setup of air cooling[16]

Another type of air cooling is a cabin air cooling system in which air is preconditioned by the help of VCC. This system only needs some of the additional components, such as a condenser, expansion device, compressor device. There are also tubes for blowing the air into batteries by fans [13]. The cabin air cooling configuration is shown in **Fig.5.**[13]. J. Cen et al. [1] experimented with the cabin air cooling method, and the result shows that maximum temperature difference in the battery module close to 2°C and also they used PID control for effective thermal management.

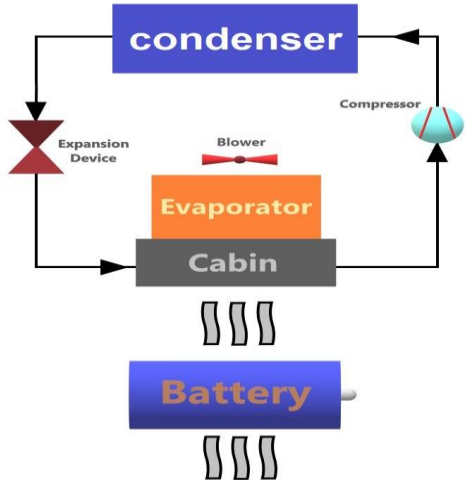

**Fig. 5.** Cabin air cooling system [13]

#### Advantages:

The advantages of air cooling are

1. It is cheaper
2. It requires fewer components so does not need enough space
3. Its installation and maintenance cost is low.

#### Disadvantages:

1. Air has a less specific capacity and heat transfer coefficient lower than many other mediums, so the efficiency is less than other cooling systems.
2. It needs much power consumption for the fan.
3. Outside dust and pollutants also flow with air in the battery pack which may reduce the performance.

#### Challenges:

Because of low air heat capacity, small thermal conductivity, and poor average temperature effect between batteries, it is only suitable for the low-density battery. Large strings of batteries require large flow channel, which makes the system bulky. An active air-cooling system uses fans to increase the heat transfer capacity, but it increases the cost and generates a lot of noise that affects passengers' comfort. To improve the performance of air cooling, effective measures can be taken such as increasing the air volume, flow rate, channel size, and optimizing cell position without compromising the space utilization[14]. Porous metal foams can be partially or completely added to airflow channels or integrated with the heat sinks to improve the battery performance [17].

### 2.3.2. Liquid Cooling

Air cooling is not efficient enough to extract heat. The liquid cooling system is more efficient and can reduce more temperature of the battery pack than the air cooling system. It can absorb more heat than air.

Like a cooling system with air, a liquid-air cooling system can also be divided into active and passive liquid cooling. In a liquid cooling system, the heat transfer fluids (HTF) absorbs heat from the battery. Then the heat is transferred to the external air, which is evacuated by the exhaust fan[18]. The active cooling system requires some active components like evaporator, pump, heating core, coolant, and sometimes electric heater and fuel heater to transfer heat and heat exchanger devices like liquid/liquid heat exchanger. [18]. The active liquid cooling system has a higher efficiency than the passive cooling system. The liquid cooling configuration is shown in **Fig.6.**[19].

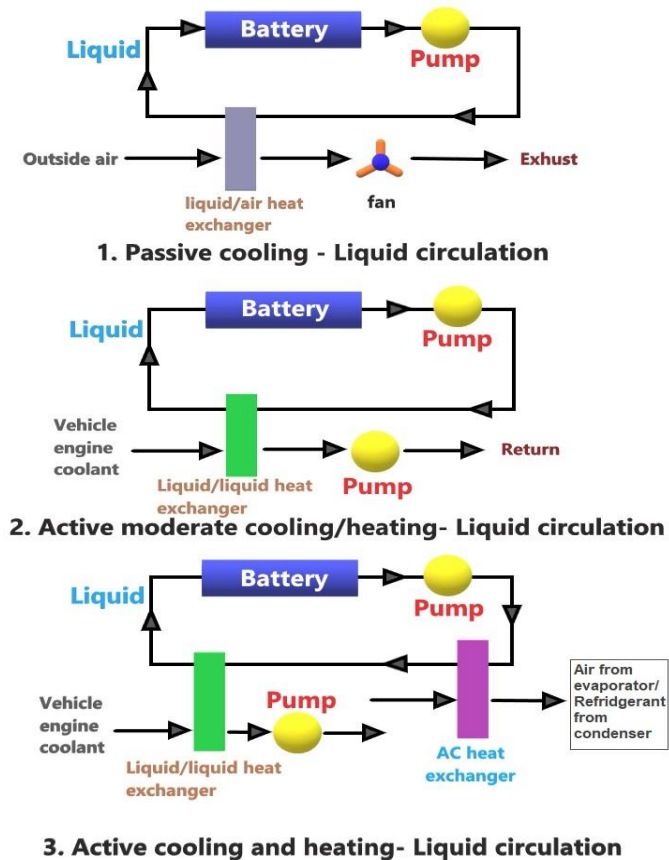

**Fig. 6.** Schematics of active and passive liquid cooling[19]

Based on the contact of the fluid with the surface, the liquid cooling system can be divided into the direct and indirect liquid cooling system. In a direct liquid cooling system, the HTF is in direct contact with the battery surface.[15]. High viscosity coolants are used as oil. So it needs more power consumption.[4]

In an indirect liquid cooling system, the liquids are passed through a metal plate with a tube or integrated channel. Generally, low viscosity fluids (water, glycol, etc.) are used in this system to transfer heat so it needs less power consumption [15]. Though the direct cooling system has more efficiency than indirect cooling, the indirect liquid cooling system is naturally used in EV because of its simple implementation.

The cooling plate and the number of channels and refrigerant flow have a great impact on the cooling system. There are many investigations had already been conducted on liquid cooling. In 2020 H. Wang *et al.* [20] studied the effect of coolant flow rate for battery cooling also they study the effect of cooling mode like series cooling, parallel cooling on battery cooling. The result shows that increasing flow rate maintains the lower maximum temperature and good temperature uniformity also for their model they find a maximum temperature of 35.74 °C and a temperature difference of 4.17 °C. In 2019 Y. Lai *et al.* [21] found that maximum temperature can be maintained within 313 K when the mass flow rate is larger than  $1 \times 10^{-4}$  kg/s at a 5C discharge rate.

#### Advantages:

1. Due to higher specific heat, mass flow rate, and a faster heat transfer rate of liquid it can absorb more heat.

#### Disadvantages:

1. The design of this system is complex.
2. The installation cost is higher than the air cooling system.
3. More component needed than air cooling which increases weight and takes more space

#### Challenges:

The main challenges of liquid cooling is its complex layout that increases the size and cost and the possibility of leakage. In addition, it needs a circulating pump, which requires more space. For active cooling, it also utilizes extra energy.

For better cooling, oil, ethyl glycol, and acetone can be used instead of water because they have a better cooling effect [14]. By controlling the circulating liquid flow rate in the liquid pump, the energy consumption can be reduced together with improved work efficiency.

### 2.3.3. Phase Change Material Cooling System

PCM based cooling system has widely been used in many industries and engineering level. Both Air and Liquid cooling system requires some components which makes the system bulky and take more space. Besides power consumption makes it less efficient. Through phase changing, process PCM can absorb or release large amounts of heat energy that serve as latent heat at a certain temperature without energy consumption.[13]. Its installation cost is less, and it is non-corrosive and with large latent heat thermal management system[15].

In the PCM cooling system, the cells are directly in contact with PCM so the heat is conducted from cell to PCM. There are also plates on the top side and bottom side or right side and left side of the PCM to release the heat energy absorbed by the PCM.[13]. Phase change BTMSs are of two types, solid to liquid cooling and liquid to gas/vapor cooling[22]. However, recently the third type PCM proposed by C. Xiao *et al.* in 2020, which is solid to solid phase change material[23]. During the charging and discharging phase, a lot of heat is produced. The heat is transferred to PCM due to conduction phenomena. PCM material absorbs the heat energy and reaches to melting point temperature. Then the PCM absorbs a lot of latent heat until changing its phase at this constant temperature. After the changing phase, the temperature gradually rises. So PCM can absorb a lot of heat energy. The heat is transferred back to the cell during the relaxation period so that the optimum temperature can be maintained. The PCM cooling configuration with aluminum fins is shown in Fig.7.[24].

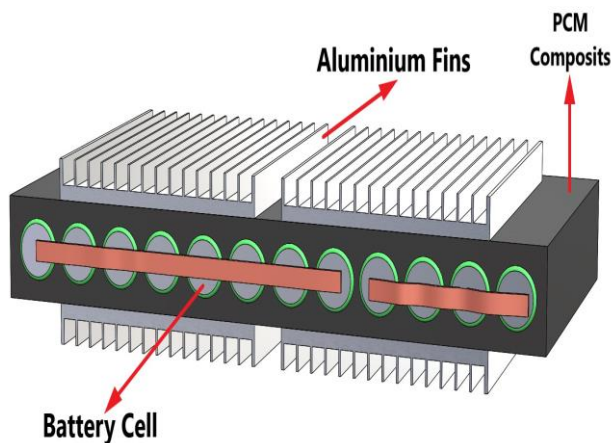

**Fig.7.** Configuration of LDPE/EG/paraffin composite PCM material with cells and aluminum fins [24]

Pure paraffin has been used which is a low-cost material with a large latent heat but it has low thermal conductivity (0.1–0.3 W/(mK) leakage problem in the molten form[25].

A mixture of two various PCM can solve this problem known as C-PCMs. Researchers showed that phase change temperature of expanded perlite composite with 25% and 45% paraffin increases approximately 1 °C to 1.5 °C than that of paraffin wax. They also retained latent heat and phase change temperature after 100 cooling cycles. They were also stable up to 155°C without leakage[26]. A mixture of Paraffin-Expanded Graphite (PA-EG) has good conductivity. So, it is evident from the literature review that composite PCMs have higher thermal conductivity than pure PCM.[17]

Using aluminum foam as thermal insulator also gives good results.[27]. In 2019 A. Verma *et al*[28] studied the effect of Capric acid as PCM and the result shows that the maximum temperature of the battery was 305 K at 3 mm thickness of PCM layers. In 2018 P. Ping *et al.* [29] have used PCM as a fins structure and the result shows that the system has good thermal efficiency at the maximum surface temperature of the battery under 51 °C and 3C discharge rate. The leakage problem of PCM can be addressed by the solid to solid PCM which is proposed in [23]. In this work, they have used crosslinking polymeric structure as well as aliphatic side chains, which was named as polymer PCM. Results show that the maximum temperature as well as the temperature difference of the battery modules can be controlled below 45.3°C and 3.1°C respectively at a cycle (charging and discharging). As shown in [23], the thermosetting 3D cross-linking structure of polymer PCM can give higher heat tolerance without any leakage at 250°C.

**Advantages:**



1. This system does not need many components. Therefore, it is lightweight. It occupies less space than air and liquid cooling.
2. It does not consume any power.
3. It is environmentally friendly, has higher efficiency and green characteristics.[14]

#### Disadvantages:

1. PCM has low thermal conductivity.
2. If material completely changes its phase temperature regulation fails and becomes difficult to operate continuously.

#### Challenges:

The issues of PCM cooling are its low thermal conductivity and volumetric expansion during phase change. If the melting point temperature of the phase change material does not match with that of the battery operating temperature it will be of no use in cooling.[17].

To improve the thermal conductivity of PCM, metal fin, metal or graphite foam could be inserted into the PCM sleeve. In addition, adding metal powder, expanded graphite powder, nanoparticles, or nanotubes with PCM can also be considered[14].

To increase the performance some additives of higher conductivity can be added with PCM like expanded graphite known as composite PCM(C-PCM). Other C-PCMs can be added such as Multi-Walled Carbon Nano-Tubes (MWCNT)-graphene. PCM of liquid to gas cooling can also be used[17].

#### 2.3.4. Refrigerant Cooling

The refrigerant cooling system functions almost like active liquid cooling, but it needs additional components. [15]. It uses a vapor compression cycle that may already exist for the Air-Conditioned system in the vehicle.

It needs an additional evaporator which is connected parallel with the evaporator of the existing AC of the vehicle. Both the AC and refrigerant cooling run by the same VCC. The refrigerant cooling cycle is extended parallel with the existing AC.[13] It not only effectively reduces vehicle weight but also achieve high-temperature cooling which improves vehicle specific energy and economy.[14]. The refrigerant cooling configuration is shown in **Fig.8.** [14].

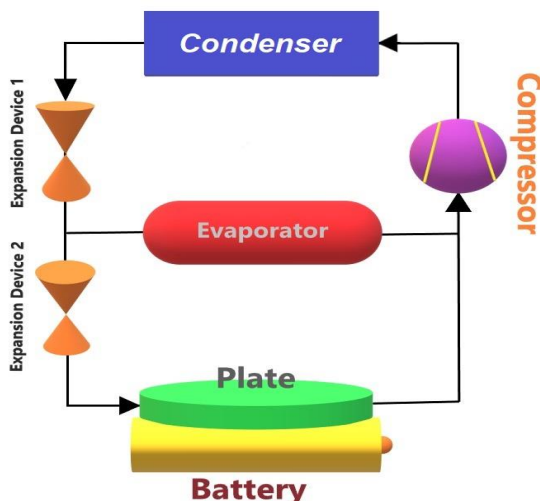

**Fig. 8.** Configuration of the refrigerant cooling system[14]

In a refrigerant cooling system a closed refrigeration system is used to pump the refrigerant. The liquid refrigerants absorb heat from the battery pack at low pressure and temperature during evaporation and change its phase to vapor. Now, this low-pressure, low-temperature vapor is passed through the compressor. The compressor compressed it into a high-temperature, high-pressure vapor. Then it is discharged to the condenser by a pump. In the condensing process, the vapor rejects its heat to the surrounding and turns into a liquid refrigerant. This liquid refrigerant is expanded by an expansion device and again pumped into the evaporator. Different types of refrigerants used in the refrigerant cooling system. There are many investigations had already been conducted on refrigerant cooling. In 2018 J. Cen *et al.* [30] used the vehicle air conditioner system with finned tube heat exchanger for Pack type battery cooling. The result shows that it can control temperature rise effectively at a high ambient temperature like 40°C. It also maintains temperature uniformity and can maintain temperature difference in pack less than 4 °C at discharge rates 0.5 C, 1 C, and 1.5 C in laboratory. In 2014 P. Kritzer *et al.* [31] developed a cooling system with CO<sub>2</sub> as a refrigerant for controlling the thermal runaway. The test was conducted at a 5C high charge rate. They used a 20s pulse of expanded CO<sub>2</sub> to reduce the temperature from 93°C to -49°C instantly. When the CO<sub>2</sub> pulse stops the temperature rises again. The system is used to slow down the thermal runaway.

**Advantages:**

1. This system can be integrated with the existing AC system, so only a few extra components are needed.
2. Refrigerant side temperature is maintained which can also be used in BTMS. So, in the cooling, it is possible to maintain proper and fixed temperature and the temperature is distributed uniformly[13].

**Disadvantages:**

1. The system needs additional components that increase power consumption.
2. To run the vehicle in a cold climate it needs to integrate extra heaters or another heat pump system. So, in winter application it is difficult to consider in an electrified vehicle application[15].

**Challenges:**

A coiled tube or cold plate is arranged inside the battery pack as an evaporator. It is required that the battery pack has to be air protected and condensation water should be avoided during use. Together with the temperature and flow control system, optimizing the refrigerant flow control strategy can enhance the performance of the cooling system.[14]. Moreover, direct refrigerant cooling is also commonly used to immerse the battery in the saturated liquid refrigerant[32]. For refrigerant cooling multiple cooling components are needed such as pump, condenser, evaporator, and valves. A proper choice of refrigerant is also needed otherwise cooling system will not be able to cool the battery effectively. Also, refrigerant cooling on its own cannot maintain high performance. So, another cooling system also needs to be added. The requirement of extra cooling system adds design complexity.

**2.3.5. Heat Pipe Cooling System**

The PCM-based BTMS faces some problems, when it completely melts the volume expands during solidification and also low conductivity etc. As a way to eliminate these disadvantages of thermal management of the battery, the researcher have proposed an alternative system called heat pipe. This is an upgraded version of PCM based cooling. It has higher thermal conductivity and low thermal resistance.[14].

In heat pipe cooling there is an evaporator and condenser section that is attached to a closed tube casing and a wick structure. A working fluid is inserted into the pipe.[15]. **Fig.9.** shows the structure of a heat pipe. The evaporator section is engaged with a heat source that needs to be cooled (battery pack). HP is operated without power consumption. The working fluids evaporate by absorbing latent heat from the battery pack and changes its phase to vapor.

Then due to the difference in the internal pressure of the container the working fluid moves to the condenser section through the adiabatic section. In a condenser, the vapor condenses to liquid by exchanging heat with the surroundings. Sometimes the fluid is condensed with the help of an additional cooling medium (air or liquid). Then, via a capillary process, the sudden condensate fluid flows back to the evaporator through the wick structure because of capillary action. The heat pipe cooling configuration is shown in **Fig.10.**[33]. There are many investigations had already been performed on heat pipe cooling. In 2020 H. Jouhara *et al.* [34] developed a thermal cooling system with heat pipe for module type (sixteen prismatic lithium-titanate cells) battery. The heat pipe (heat mat) is designed for hot and cold climates. They found that maximum cell temperature significantly decreases and temperature uniformity is enhanced. The result shows that maximum cell temperature maintains below 28 °C also temperature uniformity maintained at  $\pm 1$  °C in the module. They found that the system can remove 60% generated heat by a heat mat. In 2020 Y. Gan *et al.* [35] proposed a numerical novel thermal management system with heat pipe cooling. They used wave-shaped aluminum sleeves to increase the contact area of the heat pipe. They investigate the effect of coolant flow rate, length of heat pipe condenser section also the height of aluminum sleeves for cooling. The result shows that the maximum temperature of the battery pack

significantly depends on the coolant flow rate but temperature uniformity depends slightly. They recommended a coolant flow rate of  $0.5 \text{ L}\cdot\text{min}^{-1}$  at a 2C discharge rate. The thermal performance can increase by increasing the length of the heat pipe condenser section. They found that temperature difference of the battery pack maintain  $5^\circ\text{C}$  above 60mm height of aluminum sleeve.

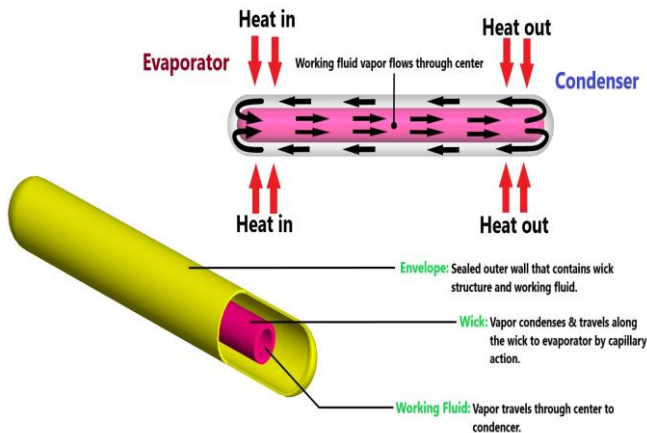

Fig. 9. Heat pipe structure

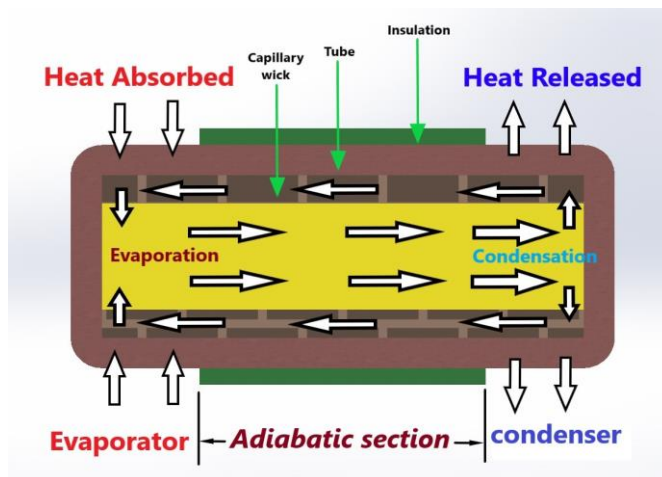

Fig. 10. Schematic of heat pipe cooling[33]

#### Advantages:

1. It has higher thermal conductivity than PCM based cooling
2. It can decrease the maximum temperature rise without any power consumption.
3. It has no moving parts so that the heat pipe is calm and noise-free
4. It is highly dependable.
5. HP cooling is compact, light, and has a flexible structure.
6. It requires low maintenance and has an excellent long-cycle life.[15].

#### Disadvantages:

1. HP has low capacity and efficiency and a small contact area.
2. Heating the battery could not be achieved effectively.

#### Challenges:

Heat pipe has good conductivity but has a small contact area and a high risk of leakage. It is also relatively expensive because of its compact design and fabrication complexities. The use of copper also makes it bulky and expensive. The use of aluminum can reduce the cost as well as the weight.

Flat heat pipe as an effective and low-energy cooling device for Li-ion battery in HEV application has been reported in [36]. It can be used in a vertical and horizontal position.

Oscillating Heat Pipe (OHP) cooling system is also an effective cooling technique. It consists of a long evaporator section, a short condensing section, and serpentine loops with eight turns. Heat transfer performance of the OHP system mainly depends on the filling rate of the working fluid. The heating rate is proportional to the optical VF[37].

### 2.3.6. Thermoelectric element Cooling System

The thermoelectric module can be used for both heating and cooling purpose. It can convert the electric voltage to temperature difference and vice-versa. The applications can be divided into two different groups. One is the thermoelectric generator (TEG) which converts heat into electricity. It is used to reduce heat from heat sources that need to be cooled (battery pack). It is based on the Seebeck effect. Another one is a thermoelectric cooler (TEC) that converts electricity into heat based on the Peltier effect. It is served as heating [13]. A single unit of TEC consists of TE legs which are connected electrically in series and thermally in parallel. TE legs are of p-type and n-type. [38]. If a voltage is applied that way the current flows from the N- to P-junction, it refrigerates the part of the module in contact with it. The other side of TE is heated. It can serve as heating. Heat sinks and air-cooling media are integrated into the system to contain the heat and enhancing the heat rejection, in general. The reverse process of it is an exothermic[15]. The thermoelectric element cooling configuration is shown in Fig.11.[39]. There are many investigations had done on the thermoelectric element cooling system. In 2019 Y. Lyu *et al.* [38] proposed a model of thermoelectric cooling with forced convection and liquid cooling. They found that the surface temperature of the battery is decreased from 55 °C to 12 °C for a single cell with copper holder by applying 40V and 12V to the heater and thermoelectric cooler respectively. In 2020 C. Qiu *et al.* [40] proposed a thermoelectric cooling model with a non-constant cross-section base on a numerical investigation. The result shows that for non-constant cross-section, cooling capacity and coefficient of performance is enhanced 35.73% and 21.59% respectively compared with a constant cross-section. In 2020 C. Selvam *et al.* [41] proposed a model of thermoelectric cooling with PCM using COMSOL Multiphysics. The result shows that there increase the temperature difference between hot and cold side. They found that enhancement of thermoelectric cooling are 36.7%, 33.8% and 30% with 0.1 W, 0.15 W and 0.2 W heat inputs respectively with 3 mm PCM height.

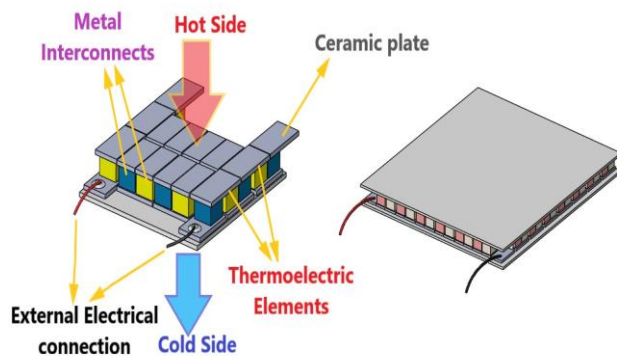

Fig. 11. Schematic diagram of the thermoelectric cooling module (TEC)[39]

#### Advantages:

1. It has no moving parts and working fluid.
2. It is easy to switch between cooling and heating operation[42]
3. It is small in size and light-weighted.

#### Disadvantages:

1. It has not only low conversion efficiency but also the high material cost of thermoelectric elements.

#### Challenges:

Lower efficiency of this system makes it incompatible for battery cooling. TEC can provide higher efficiency when used in conjunction with other cooling systems. For N-type and P-type systems, higher conductivity materials have to be used. Since thermoelectric cooling uses DC current, improper control of current flow will induce heat. In addition, the thermal efficiency of TEC is not adequate in comparison to refrigerant cooling. So, there are scopes to improve the design of TEC to increase the thermal efficiency.

## 2.4. Cell level cooling strategy

The electric vehicle is operated by battery electricity. For the different operation of different electric vehicles, there are different configurations of batteries like cell configuration, module configuration, and pack configuration. For a different type of battery configuration, there needs a different type of cooling strategy. Several studies have been carried out for cooling cell type battery. Table.1 shows the cell level cooling of Li-ion batteries. In 2018 Wei & Chaab [43] proposed a hybrid model of the thermal management system. In their model, they used a simple air cooling duct that can achieve effective cooling also used hydrophilic fiber channels with water coolant forced air coolant. **Fig.12** [43] shows the configuration. Their result shows a better performance for high energy and power density batteries. It decreases the maximum surface temperature from 55<sup>0</sup>C when no-cooling to 30.5<sup>0</sup>C. It decreases the temperature difference from 13.5<sup>0</sup>C when no-cooling to 2.1<sup>0</sup>C. To decrease the maximum temperature and increase the time to cause thermal runaway in high discharge rate and high energy density battery, Yamada et al proposed a PCM/heat pipe combination model in 2017 [44]. In their model the working fluid was water. They have used a heater as a heat generator instead of a Li-ion battery. In their model, they found that after the 60s the maximum temperature was 44.3<sup>0</sup>C. They also test the thermal runaway and they found it after 708s with a high temperature of 80<sup>0</sup>C. Wang *et al.* [45] in 2017 has proposed a model for one prismatic cell. In their proposed system they used a liquid cooling system with silica plates and copper tubes. They have used different discharge rate like 2C, 3C, 5C. They test their experiment by varying silica plate, discharge rate. They found that below 3C discharging rates the maximum temperature of the cell was 39.1<sup>0</sup>C. They noticed that by increasing the number of the plate and also copper tubes the efficiency of their battery thermal management system. In 2018 Wu et al.[46] proposed a BTM system with one prismatic cell. In their model, they used PCM combined with expanded graphite by natural convection. They observe the battery performance by changing the PCM thickness. They saw that with increasing thickness of the PCM the efficiency increased, also by increasing heat transfer coefficient (convective) the efficiency of the BTM system increased. In 2016 Chen et al [47] proposed a cooling method with four approaches are air, indirect liquid, direct liquid, fin cooling. They fixed the heat energy generation of the battery at 15.7 W with a discharge rate of 2.71C. They found that the air cooling system needs 2 to 3 times greater energy to maintain the same average temperature than other methods. Also, indirect liquid cooling keeps minimum-maximum temperature rise fin cooling increase 40% more system weight. They say that indirect cooling is better for application. In 2017 Panchal [48] proposed a model of Li-ion prismatic cell with mini channel cold plate (2 plates) cooling. One plate is situated at the top side of the cell and another one is situated at the bottom side of the cell. They noticed that increasing discharge rates also increasing operating temperature leads to an increase in the cold plate temperature.

**Table 1 Cell level**

Max $\Delta T$ ( <sup>0</sup> C)						
2.1						
-						
-						
5						
-						
-						

Author	Cooling materials	Battery configuration	Load on Battery	Cell capacity	Max T ( °C )
Wei, Y., & Agelin-Chaab, M. (2018) [43]	Forced air cooling and liquid cooling by fiber channels	one or multiple batteries	Less 0.2C charging 1.15C discharge	5.2Ah	30.5
Yamada et al. (2017) [44]	Water(20heatPipes)/PCM	Heater	400W	-	44.3
Chen et al(2016) [47]	air, direct liquid, indirect liquid, and fin	prismatic pouch cell	2.71C discharge	35Ah	Rise(8°C), air n 400 W/m <sup>2</sup> k, liquid 500 W/m <sup>2</sup> /k, fin 300.W/(m <sup>2</sup> K)
Wu et al.(2018) [46]	PCM/EG composite	lprismatic cell	5C	12Ah	53
Wang et al.(2017) [45]	mini-channel cold plate (water)	lprismatic cell	Below 3C	20Ah	39.1
Panchal (2017) [48]	mini-channel cold plates	lithium-ion pouch cell	1C & 2C discharge	20Ah	-

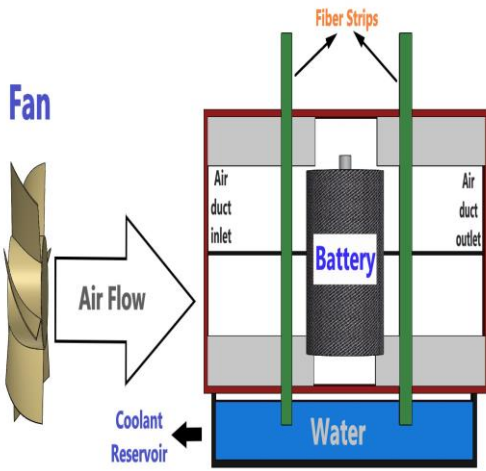

**Fig. 12.** Illustration of the hybrid cooling design. [43]

**2.5. Module level and Pack level cooling strategy**

Li-ion batteries are a game-changer in materializing electric vehicles. Usually, these vehicles are heavy and thus require high power to operate. Currently, batteries are used in electric vehicles via a combination of cell level, module level, and pack level configuration. For different types of battery configuration different methods of cooling techniques are required. Cooling strategies adopted for batteries at the cell level are described in the previous section. Similar to cell levels, different cooling strategies are also for batteries at the module and pack levels.

EV motors need high voltage to operate. So, thousands of cells are needed to provide the required high voltage. To achieve this, large number of cells are configured into modules and packs. The module and packs are covered by frames and mechanical systems to prevent any externally induced effects and to ensure a longer life time.

When a large number of cells are connected in a serial and parallel connections and put in a frame, then, that configuration is known as a module. In module configuration, cells are connected in a systematic manner to get higher voltage. When a number of modules are connected in a systematic manner as per the specifications, then, the configuration is known as a pack configuration. The block diagram of the sequence of cells connection are given in **Fig. 13**. There are some differences between the module and the pack. Some cooling challenges of module and packs briefly summarized in **Table 2**.

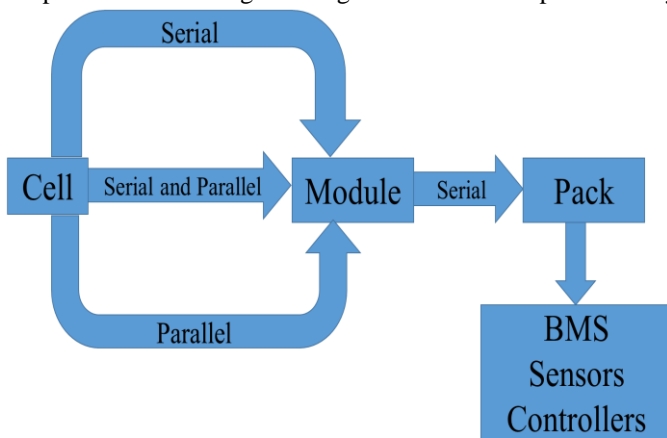

**Fig.13.** The block diagram of the sequence of cells connection.  
 \*BMS (Battery Management System)

**Table 2** Cooling System for Module and Pack

Module	Pack
<ol style="list-style-type: none"> <li>1. A cluster of cells make up a module[49].</li> <li>2. A frame to protect them from external shocks and waves,</li> <li>3. Cooling in module comes from the divisional part of main cooling system.</li> <li>4. Modules are gathered together to create large amount of voltage.</li> <li>5. In an electric vehicle module level battery pack are not directly installed.</li> <li>6. The structural arrangement of battery cells is very important in module level battery cooling[50].</li> <li>7. The bus bars in module are thin and have less electrical strength.</li> <li>8. The cell connectors are used to connect the cell.</li> <li>9. Air cooling is the simplest technique in module level cooling. But it has lower thermal coefficient and non-uniformity. This problem can be minimized by high airflow and increasing channel size. But it will increase the cost as well as complexity</li> <li>10. Uneven cell spacing on the module affects the temperature distribution by air cooling[51]</li> <li>11. PCM cooling have low thermal conductivity, needs composition of materials with PCM to increase efficiency.</li> <li>12. In liquid cooling the working medium needs low melting point temperature to nullify the effect of liquid to solid phase change of working fluid in module , it is also for pack.[52]</li> </ol>	<ol style="list-style-type: none"> <li>1. A cluster of modules make up a pack.[49]</li> <li>2. A final mechanical frame contain the modules under battery management system.</li> <li>3. The main cooling system is applied on pack.</li> <li>4. The power source of EVs is pack.</li> <li>5. In an electric vehicle battery pack are directly installed.</li> <li>6. In pack level cooling the arrangement of battery module is not so important as the cells in module[50].</li> <li>7. The bus bars in pack are thick and have high electrical strength.</li> <li>8. Module connector are used to connect the module.</li> <li>9. Final mechanical frame contain the sensors, controllers for controlling the voltage and current.</li> <li>10. Liquid cooling in pack level has complex layout as well as it needs more space.</li> <li>11. PCM cooling in pack has low conductivity and volume expansion.</li> <li>12. Refrigerant cooling in pack is costly.</li> <li>13. Heat pipe cooling in pack has low contact area. [53]</li> <li>14. TEC cooling in pack has low efficiency. [53]</li> </ol>

Research have been conducted on module level cooling and pack level cooling. We are going to present it individually.

In the case of module level cooling, it has been seen that the temperature of the battery should be maintained at the lowest 15°C to the highest 35°C[9]. Otherwise, the temperature will affect the lifetime of the battery. To maintain this temperature module-level cooling strategy is very important.

For a good long-lasting life of a battery, it is expected to maintain the difference of temperature between the cell's and module less than 5°C[54]. It has been noticed that excessive heat and the distribution of temperature among the battery cells in a module is one of the key reasons for the early degradation of battery life. Moreover, it can also be a reason for the failure of battery cells [12, 55-57].

To increase the battery cell's life in a module depends mainly on the structure of arranging the battery cells as well as the cooling procedure that has been taken to cool the battery module[50]. In a battery module, the cells are arranged very close to each other. So the performance of battery cells mostly depends on the operating temperature of a module [58, 59].

The module type configuration is shown in **Fig.14**. [60]. A well-designed cooling strategy is very important to maintain high performance in a battery pack. The different mediums can be used for heat transfer. The medium can be air [58, 61], liquid [62, 63], phase change material [64-66] and heat pipe [12, 67].



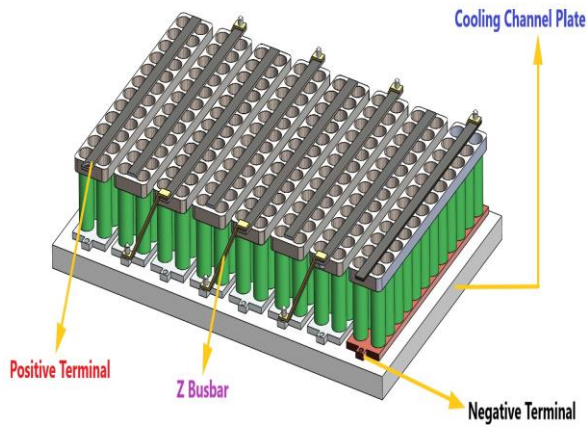

**Fig. 14.** Series connection of half module (eight battery).[60]

The structural arrangement is very efficient in the cooling of the battery module. 1\*24, 3\*8 and 5\*5 arrays rectangular arrangement is efficient. Moreover, 19 cells in a hexagonal arrangement and 28 cells in a round arrangement are also suitable in module level cooling [50]. **Table.3.** [50] shows different cell arrangement.

**Table 3** Average temperatures of different battery arrangements[50]

Cell arrangement names	Average temperature
1* 24 Cell arrangement	34.4708°C
3*8 Cell arrangement	33.5501°C
5*5 Cell arrangement	32.7560°C
19 Cells hexagonal arrangement	32.6095°C
28 Cells circular arrangement	34.2929°C

Another cooling process is air-cooling which is the most used process and conventional approach in EV battery cooling. Usually a fan is used for air cooling. The distribution of temperature depends on the location of the fan[68]. Shahabeddin K. Mohammadian, Yuwen Zhang showed that the maximum temperature of a battery module reduces by 7.0%, 6.2%, and 6.5% at channel airflow speeds of 0.206 ms<sup>-1</sup>, 0.412 ms<sup>-1</sup>, and 0.824 ms<sup>-1</sup> sequentially(in Celsius).[69]

It has been seen that a 5\*5 cell arrangement with a fan on the top of the module is the most efficient for cooling. **Fig.15.** shows the different positions of fans in a battery module.

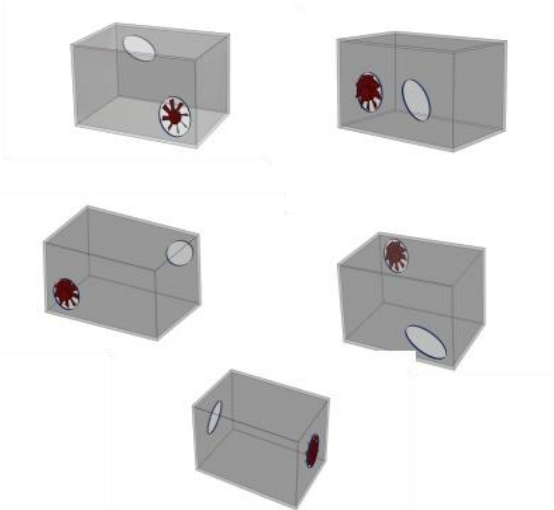

**Fig. 15.** The different position of fan in a battery module.

Tao Wang, K.J. Tseng, Jiyun Zhao, and Zhongbao Wei showed that cell distance in a module has also an effect on cell temperature. If the cell distance is 0 mm the maximum temperature is 35.0807 °C. However, if the cell distance is increased up to 2mm the maximum temperature is found to 34.0112 °C. Again if the cell distance is kept at 3 mm the maximum temperature is found 34.5770°C[50]. **Table.4** shows the outcome of temperature on the distance of the battery cell on the module

**Table 4** Effect of temperature on the distance of the battery cell on the module.

Cell distance	Maximum temperature
0 mm	35.0807 °C
2 mm	34.0112 °C
3 mm	34.5770°C

Now, in the case of pack level cooling, strategies are needed to manage the cooling system effectively because of, in a pack there have thousands of cells and also those induce more heat. In past, much research was carried out on pack level cooling, and also recently researchers are trying to make an efficient cooling management system for pack-type cooling. **Table.5.** shows the different cooling procedure used by researchers. In 2017 Xie *et al.* [70] proposed a model by air cooling. In their model mainly they checked the effect of inlet airflow angle and outlet airflow angle, they used the newton method, CFD (computational fluid dynamics), and resistance network model for numerical calculations. The result showed that the maximum operating temperature and temperature difference was reduced close to 12.82% and 29.72% respectively with an inlet flow angle 2.5° and outlet flow angle 2.5°. So perfect modeling of the inlet and outlet angle can improve the efficiency of the BTM system. In 2017 Chen *et al.* [71] proposed a BTM model for pack type battery. In their model, they attempted to analyze the effect of varying the width of the inlet and outlet airflow path. They have used CFD (computational fluid dynamics) model to evaluate the airflow. The numerical analysis showed that when the inlet flow rate and heat generation of the battery remains constant the maximum operating temperature of the battery pack can be reduced up to 41%. They also used some other methods like the newton method to optimize the standard deviation of flow velocity of air. In 2018 Hong *et al.* [72] proposed a model by air cooling using a secondary vent. In their model, they varied the position of the secondary vent and noticed the effect on the temperature of the battery pack. Since the position of the vent was at the wall of the outlet duct and they found that when the position of the vent was at the convergence plenum of the battery, the maximum operating temperature of the pack and temperature difference was decreased by 5K and 60% respectively compared with the BTM system without secondary vent. So, the secondary vent was very effective in their study to improve the thermal performance of battery pack.

In 2018 Ye *et al.* [73] proposed a cooling model by a flat heat pipe and conductive fins. They designed their model with a flat micro heat pipe considering the contact area between heat pipes and battery. In their model, they increased the contact area for

increasing the cooling efficiency. In their study they used 18A current and find maximum operating temperature as well as temperature difference below 35°C and 1.5°C respectively, also they mentioned that efficiency will increase with force convection by air. In 2018 Feng *et al.* [74] showed a model with a heat pipe cooling device (HPCD) and analyzed the effect of force convection (Fan) and natural convection. They used non-destructive temperature equipment and strain gauges to monitor the operating temperature and the strain of the 18650 Li-ion battery pack. The result shows that the force convection with heat pipe can maintain a good temperature for the battery pack but for natural convection cooling strategy, it was not good at the end period of the discharging process. In 2019 Cao J *et al.* [75] proposed a hybrid cooling system consist of liquid cooling and PCM composite. They used cold plates and expanded graphite with RT44HC composite. In their model, the configuration of the pack was a 5S4P structure, where the series configuration has 5 cells and the parallel configuration has 4 cells (20 cylindrical cells). Silicone grease was used between cold plates and battery to reduce the thermal resistance of air due to the conductivity and density of silicone grease are higher than air. They studied the effect of water inlet operating temperature and flow rates, also PCM content in a battery. The best performance was found below 40°C inlet water temperature but an increase in airflow rate increases the power consumption. They checked the effect of paraffin on their experiment and found that EG/PCMs combine with 25 wt% and 67 wt% of RT44HC (paraffin) decrease the maximum temperature from 50°C to 44°C and 42°C, a planner temperature difference was reduced from 5°C to 2.3°C and 1.2°C at high discharge rate 2C.

In 2020 H. Zhang *et al.* [76] proposed a BTM model by cold plates with special channels. They studied with cell type and pack type battery configuration. In the pack type, they made 6s4p configuration (6 are in serial and 4 are in parallel in a stage) with a multi-domain modeling framework (3D). **Fig.16**[76] shows their model. They have used Newman, Tiedemann, Gu, Kim (NTGK) model for modeling their BTM system. Their result shows that with a 5C discharge rate maximum temperature and temperature difference of the Pack was maintained below 40 °C and 5 °C respectively when the cold water flows through channels into the center position of the battery pack.

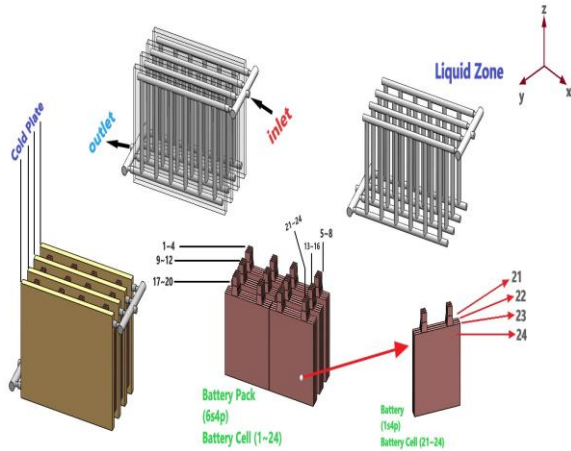

**Fig. 16.** Configuration of the 6s4p battery pack [76]

Max T (°C)	Max ΔT (°C)
51.85	3.7
56.05	7.4
34.45	4.47
Below 35	1.5
Below 39	-
Below 40	Below 5
44 and 42	2.3 and 1.2

Author	Cooling materials	Battery configuration	Load on Battery	Cell capacity
Hong et al (2018) [72]	Air cooling	24 pouch cells (Pack)	5C	2.2Ah
Chen et al (2017) [71]	Air cooling	24 pouch cells (Pack)	6.5W	2.2Ah
Xie et al (2017) [70]	Air cooling	10 prismatic cells (Pack)	3.82W per cell	-
Ye et al (2018) [73]	Flat heat pipe and fins	16 prismatic cells (Pack)	1C	18 Ah(cell)
Feng et al (2018) [74]	Heat pipe cooling device (HPCD)	24 cylindrical cells (Pack)	0.5C	2.6Ah
H. Zhang et al (2020) [76]	cold plates with special channels	24 prismatic cell (Pack)	5C	20 Ah nominal capacity 4 parallel cell
Cao J et al (2019) [75]	Cold plates, PCM (EG-RT44HC)	20 cylindrical cells (Pack)	2C	2.6Ah

So many investigations have been conducted to maximize the thermal efficiency of Li-ion battery module and pack and also researchers are trying to make hybrid cooling configuration for the upcoming battery challenges.

### 3. BATTERY THERMAL MODELLING TECHNIQUES

Since Li-ion batteries induce heat energy during operation, it is important to have a proper modeling technique for controlling the temperature in the battery system.

There are three battery thermal dimensional modeling techniques which are 1D, 2D, 3D also another one is a lumped model. Thermal modeling of Lithium-ion batteries is well documented in the literature [77]. It uses the heat balance equation that calculates the temperature with the generated heat and it also calculates heat losses. J. Jaguemont *et al.* in 2019 investigated the 1D method on two battery technologies one is high power and the other is high-energy with lithium titanium oxide (LTO) and nickel manganese cobalt oxide (NMC)[78]. **Fig.17**, [78] shows the 1D electro-thermal model used by J. Jaguemont *et al.* in 2019. 2D and 3D models are used for the cylindrical cell. The model varies for different sizes of the battery, like for small size 2D and for large size 3D model are used [4]. The 3D model is used for axial boundaries like a cylinder and also for plane boundaries like prismatic shape. The 3D model is very effective for all types of boundary shapes. The main purpose of using the thermal mode is to stabilize

the temperature distribution. According to the purpose different types of Battery thermal models are used. By using the Battery thermal model the uniformity of temperature into the cell is occurred [79]

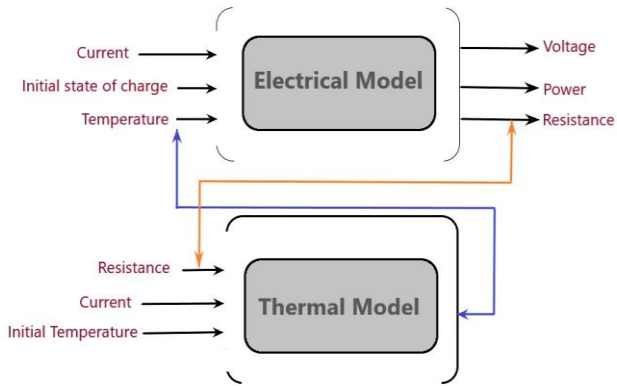

**Fig. 17.** Schematic of the modeling methodology for 1D [78]

Since the 2D model has high accuracy, also take a few input parameter. In 2014 A. Samba et al. has developed a 2D model for LiFePO<sub>4</sub>/graphite Li-ion pouch type cell with a Maximum capacity of 45Ah [80]. They have neglected heat development in the y-direction cause of the small thickness (13 mm) of their cell. **Fig.18.**[80] shows their model.

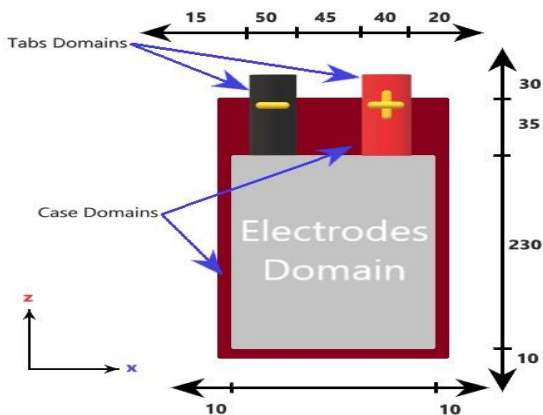

**Fig. 18.** 2D Schematic diagram and dimension (mm)[80]

They have compared the simulated result with an experimental result in different conditions. They found the maximum operating temperature difference on the surface of the battery was about 0.7 °C for a low current rate of less than 1I. However, for a higher current flow rate like more than 1I, generated heat energy is higher than the dissipated heat energy and it is not good for battery health.

For controlling the temperature a novel model was introduced by J. Gou and W. Liu in 2019. There used model is a novel 3D model with a vapor chamber (3DVC) for Li-ion batteries.[81]. **Fig.19.**[81] shows the diagram of their modeling.

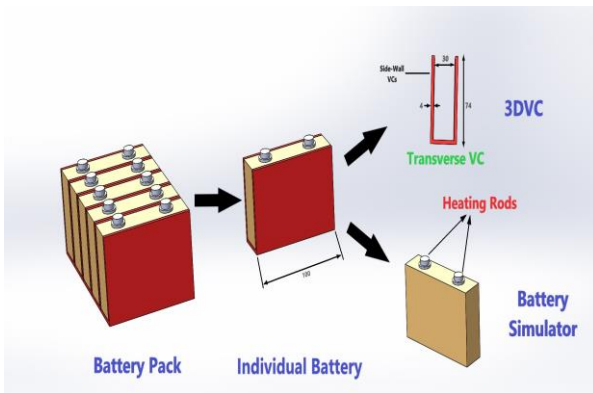

Fig. 19. Battery pack and the prototype of 3DVC.[81]

In their model, they varied the filling ratio and compared their result to understand its effect on temperature. They take 60% and 120% filling ratios. They found that for a lower filling ratio the thermal resistance decrease from 0.36K/W to 0.22K/W with a heating power increase from 10W to 60W. Also for a higher filling ratio thermal resistance decrease from 0.4K/W to 0.18K/W with a heating power increase from 10W to 60W. So they decided to apply a 120% (higher) filling ratio in practical utilization on the BTM system. From the overview, we see that for different techniques the degradation of battery temperature is different. Researchers are trying to enhance the dimensional model for confirming a better Battery Thermal Management system.

#### 4. BATTERY DEGRADATION CHALLENGES

Nowadays we are facing a great problem of global warming. Every day a ton of carbon-dioxide emission increases the temperature of the world. One of the main reasons for the emission of carbon-di-oxide in vehicles that use petrol, diesel as fuel [82, 83]. That is why the use of batteries is increasing day by day. It has been observed that the implementation of battery is increasing in recent days [84-86]. There are different types of battery but the Li-ion battery is the most used because of its long life, high energy density, high efficiency[87, 88], and low self-discharge rate[89]. Li-ion batteries have many advantages. Besides, it has some degradation challenges too. Li-ion batteries have a high primary cost during production[90]. Aging is a great factor in the degradation of battery performance. Aging affects the capacity of the battery and the available power[91]. When the battery is new it provides a good output but day by day the performance of the battery degrades. The aging mechanism is shown in Fig.20.[91] and the main overview of degradation in li-ion cells is shown in Fig.21.[92]. Several factors such as cells manufacture variability in terms of choice of material, application scenarios such as high temperature, low temperature operation results in aging related side reactions that enhances degradation and causes capacity fade and power fade. An overview of the causes and effects of battery degradation mechanisms and associated degradation modes are illustrated in Fig. 22.[93].

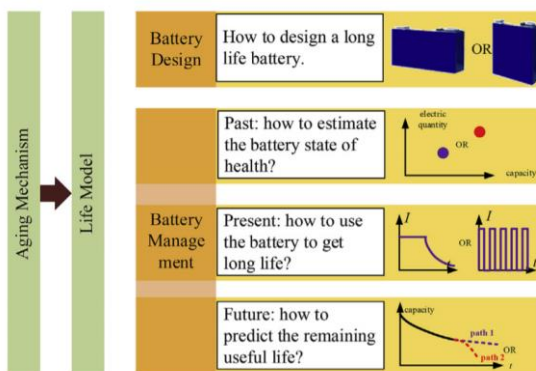

Fig. 20. Aging mechanism of the li-ion battery. [91]

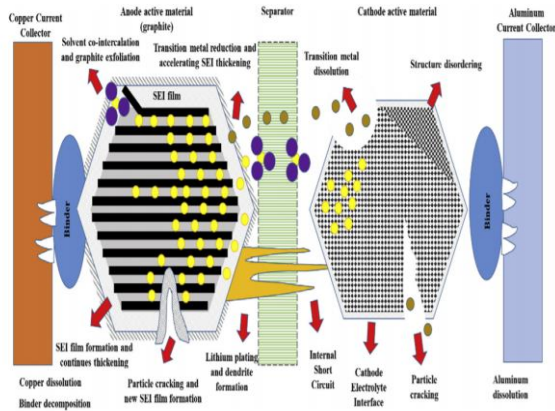

Fig. 21. The main overview of degradation in Li-ion cells[92].

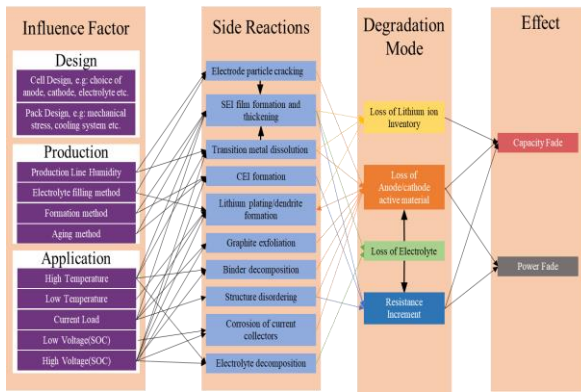
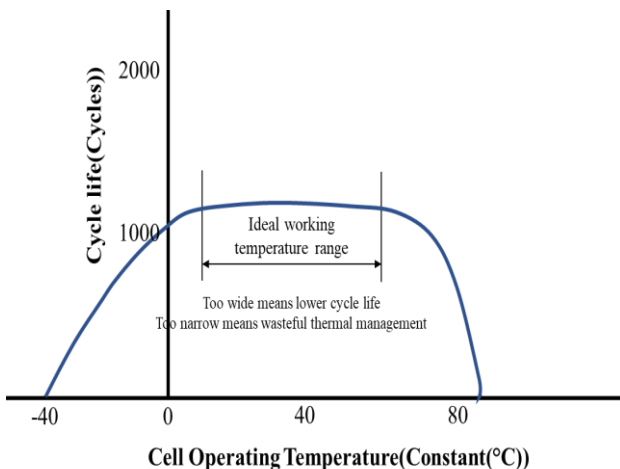

Fig. 22. An overview of causes and effects of battery degradation mechanisms and associated degradation modes[93].

There is also the thermal effect on battery degradation. It has been noticed that the battery works more reliable at room temperature. Because they are designed like that, they can work at room temperature. At low temperature, the internal resistance of the battery increases and thus reduces the capacity. It has been noticed that a battery which can provide 100% capacity at 27°C (80°F) will typically produce only 50 percent at -18°C (0°F).[11]. For example, operating temperature has significant impact on battery cycle life. Battery cycle life starts to reduce while battery temperature exceeds 45°C and significant cycle life loss occurs around 80°C. The effect of temperature on battery life cycle is illustrated in Fig.23.[94]. The growing degradation rate of the highest storage capacity throughout cycling with growing temperature is because the degradation mechanisms of irreversible capacity loss are expedited by a raised temperature, as described in multiple studies.[95-97].



**Fig. 23.** Impact of cell temperature on battery cycle life[94]

The degradation rates of all the elements in a Li-ion battery will boost because of higher temperature, and this is compatible with the work of Thomas *et al*[98]. Chongming Wang's work showed that active air cooling is the more suitable alternative than passive PCM cooling to diminish battery degradation [99]. Ziyi Ling presented a thermal network model. He made rapid optimization on PCM selection. By this, he minimized the degradation of the battery at cold temperatures. He also revealed a battery capacity degradation model that helps us to understand the influence of thermal management on battery life throughout a long period of cycling[100]. Jeremy Neubauer showed the minimal influence of cold weather on degradation as well as the minimal influence of active battery heating systems[101].

In Li-ion batteries, different types of anode and cathode are used. Some of the cathode material are Lithium manganese oxide (LMO,  $\text{LiMn}_2\text{O}_4$ ), Lithium iron phosphate (LFP,  $\text{LiFePO}_4$ ), layered metal oxide like  $\text{Li}[\text{NixCoymn}1-x-y]\text{O}_2$  (NCM), and Li-rich materials. Again some of the anode material is graphite, silicon, etc.[91]. This cathode and anode have a great impact on the degradation of the battery.

#### 4.1. Anode materials

It has been seen that the electrochemical stabilized voltage of normal liquid electrolytes is lowest 1v to highest 4.5 v[102, 103]. However, the working voltage of graphite is 0.05v[104]. That is why we can say that graphite anode is unstable. The SEI (solid electrolyte interface) prevents electron transportation. Thus, we can prevent the degradation of electrolyte and graphite-based anode could be cycled. Silicon-based anode materials are now widely utilized as an anode in Li-ion batteries. Most of the researchers are now using carbon and silicon as an anode to improve battery life and C rate performance[105].

#### 4.2. Cathode materials

To minimize the degradation of li-ion batteries most of the used cathodes are spinel LMO cathode, olivine LFP cathode, or layered NCM cathode[91].

We can identify battery degradation by observing battery performance. Most of the time the performance of the battery become fade with aging.

Battery physical resistance is also a cause of the degradation of the battery. If the internal resistance is very high there will be a high loss of energy during the time of charging and discharging. It possesses a great impact on battery performance. Again, internal resistance affects battery performance after a while. There is also a great influence on battery design on the degradation of battery life. There are mainly four levels of design. They are material level, electrode level, cell level, and system level. At the material level the anode, cathode, electrolyte, and separator influence battery life. The binder, particle radius, etc. effects at the electrode level. Cell shape, dimension, etc. in cell level and mechanical design, the thermal management system in system-level has a great influence on battery life[91]. Temperature variation is also a reason for battery degradation. If the temperature is very high in the cell it will affect the life and the performance of the battery. To overcome this, we have to focus on the cooling system of the battery in the cell, module, and pack. There is also an effect of current flow on the life of the battery. Because current flow produces joule heat on the battery. Joule heat increases the internal temperature of the battery. The current flow also influences the terminal voltage and internal potential of a battery which is the result of many side reactions. These side reactions can also reduce the life of the battery[106].

## 5. FUTURE COOLING STRATEGY

Since the electricity-dependent vehicle is increasing its demand on the utility. Electricity-operated vehicles or hybrid electricity operated vehicles battery thermal management system should control properly since in the future there will come more fast charging vehicle and their induced heat will much higher than the past battery electric vehicles. So there needs a more enhanced BTM system to control the operating temperature at an optimum range and to control the temperature distribution. Here we see that traditional BTM systems have advantages and also disadvantages. One cooling system does not satisfy the utility demand completely, so there needs a combination or mix of the traditional BTM systems. These types are like active cooling system with PCM, active liquid cooling with PCM, forced air cooling with PCM, heat pipe cooling with PCM, oscillating heat pipe with PCM, etc.



### 5.1. Active air cooling with PCM

Air cooling needs less equipment but has less efficiency, less heat rejection properties. PCM has high latent heat but it has a problem of melting when changing the phase. When active air cooling is combined with PCM the problems can be reduced. Air cooling helps to increase the time of phase change that means melting and PCM helps to reduce the battery temperature with direct contact with the battery cells. In 2014 Fathabadi et al.[107] used air-duct cooling and PCM. Ling et al. (2015) used PCM with forced air convection cooling [65]. In their experiment, they had used a pack configuration of 20 cylindrical cells in a series-parallel connection. Their result shows that using active air with PCM maintain the maximum temperature under 50°C at all cycle while without active air cooling (only PCM) the maximum temperature goes above 60°C at only 2 cycles. So with active air cooling, the PCM can reduce the maximum temperature more effectively. However, for upcoming high power vehicles, this method is not sufficient so more cooling method should develop.

### 5.2. Active liquid cooling with PCM

Liquid cooling has more thermal conductivity than air cooling also has high heat rejection performance but it requires extra equipment. When combining with the PCM the equipment could reduce slightly but the thermal performance will increase. The liquid cooling helps to cool the PCM and PCM helps to cool the battery. Since liquid helps to reduce the heat from PCM more effectively cause of its greater thermal conductivity. Y. Zheng et al.[108] have taken a battery pack of 110 prismatic cells, 8 flow tubes through which liquid flows around the PCM, PCM materials, and adiabatic layers between the cooling tubes. From their result, it has come to view that the maximum temperature maintains at 38.69°C also the maximum temperature difference maintain at 2.23 °C. **Fig.24**[108] shows the applied diagram. The result is the applicable cause of maximum temperature is not so high.

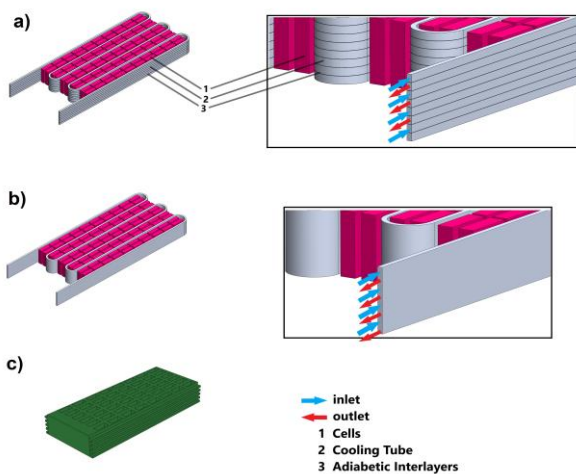

**Fig. 24.** [108] (a)Configuration including adiabatic layers (b) without adiabatic interlayers, and (c) inserting PCM

In 2019 Y. Zaho [109] et al represented a hybrid model that is copper foam/paraffin composite PCM (CPCM) with active liquid cooling. In their copper foam, there have a porosity of 98% and pore size 20ppi, also the melting point of the paraffin is 25°C. They have used a 3D numerical model using ANSYS FLUENT. They found a significant improvement in battery surface temperature was reduced by 14°C compared with the pure PCM module. They also checked with different inlet velocity. **Fig.25** [109] shows the applied diagram.

Though the liquid model with PCM is highly efficient it has a high cost for circulating pumps, extra space, etc.

### 5.3. Heat pipe cooling with PCM

PCM has high latent heat but imperfect PCM has low thermal conductivity so the only PCM cannot reduce heat for a long time. So a more effective combination of heat pipe with PCM is also more effective. Since heat pipe has high thermal conductivity but it has less contact area. When heat pipe is used with PCM it reduces heat from PCM and PCM reduces heat from battery. Since much research is running on this hybrid model. In 2017 Zhao et al.[110] have proposed a model of PCM with a heat pipe. They have taken module type cylindrical shape cells for their application. They test the battery with air cooling, only PCM cooling, and heat pipe with PCM cooling. They found that heat pipes with PCM have more efficiency than air or only PCM cooling. Their result

shows that a heat pipe with PCM can maintain the maximum operating temperature  $50^{\circ}\text{C}$  also maximum temperature difference at  $5^{\circ}\text{C}$ .

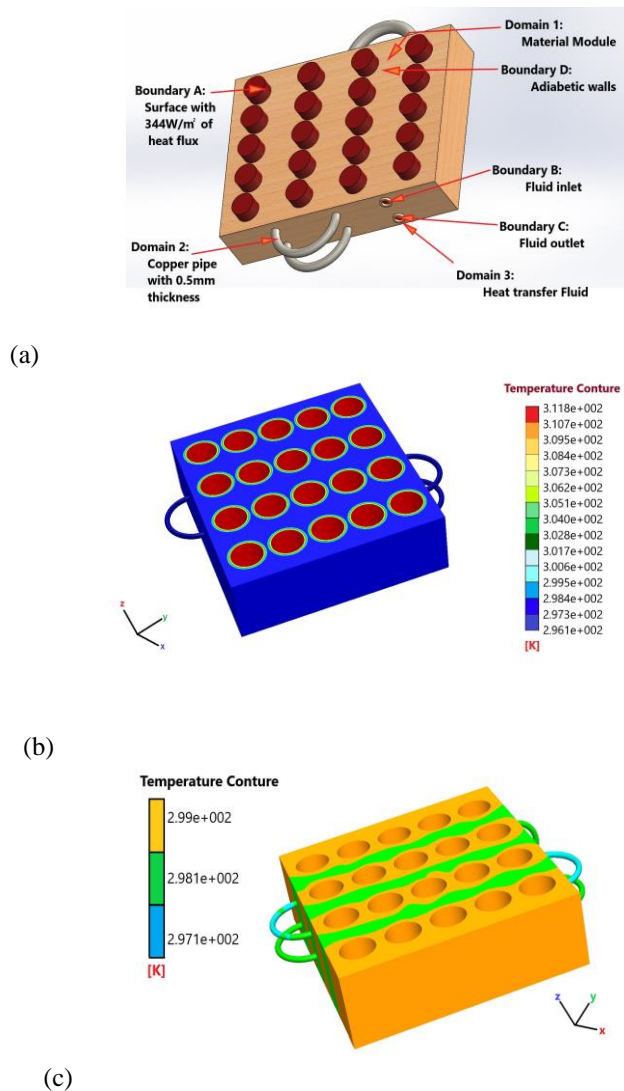

**Fig. 25.** [109] (a) Configuration of proposed BTM system (b) Contour of the static temperature of the module using pure PCM after 1800s operation (c) Contour of the static temperature of the module using copper foam composite with paraffin after 1800s operation.

In 2020, Zhang et al. [111] proposed a model of PCM/Heat pipe/Copper foam for pack type  $\text{LiFePO}_4$  battery. The position of the cooling system is arranged in such a way that the heat pipe takes heat first and transmitted to the PCM. The result shows that the maximum operating temperature was under  $45^{\circ}\text{C}$ . In 2020 Nandy Putra [112] have designed a BTM system of heat pipe with PCM and used battery simulators. They have used PCM as beeswax or Rubitherm RT44HC respectively. In Fig.26 [112]. shows the heat transfer diagram. They found that only using heat pipe reduces maximum temperature  $26.6^{\circ}\text{C}$  with a load of  $60\text{ W}$ . Also heat pipe with beeswax or RT44HC can reduce the surface operating temperature of the battery simulator by  $31.9^{\circ}\text{C}$  or  $33.2^{\circ}\text{C}$ .

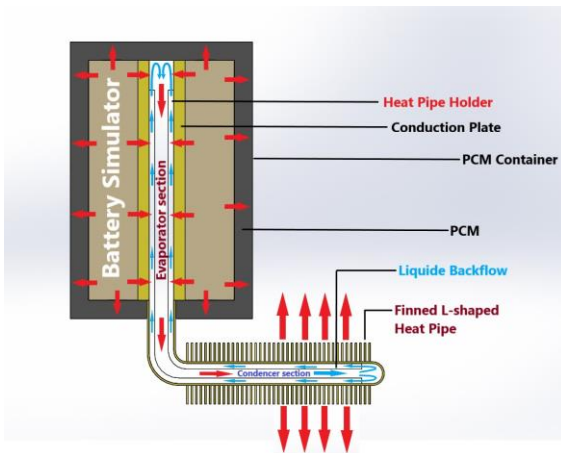

**Fig. 26.**[112] Heat transfer and exchange process in the heat pipe and PCM.

#### 5.4. Oscillating heat pipe cooling with PCM

The combination of oscillating heat pipe with PCM is more efficient than only using PCM or only using an oscillating heat pipe. There have developed many models of oscillating heat pipe combining PCM. In 2016 Qingchao Wang[113] proposed a model of oscillating pipe with paraffin as PCM. They used a battery surrogate instead of batteries and the length and width of it 115 mm and 90 mm respectively. They have used a DC power supply for heating the surrogate. The result shows that the maximum operating temperature of the battery surrogates at 800 s was 44.62 °C (20 W), 48.86 °C (25 W), and 55.56 °C (30 W) but Compared with combining oscillating heat pipe cooling system the maximum operating temperature of the battery surrogates decreased by 6.39 °C, 9.52 °C, and 8.23 °C, respectively at 20W **Fig.27.**[113] shows their configuration. Oscillating heat pipes are very effective to transfer the heat.

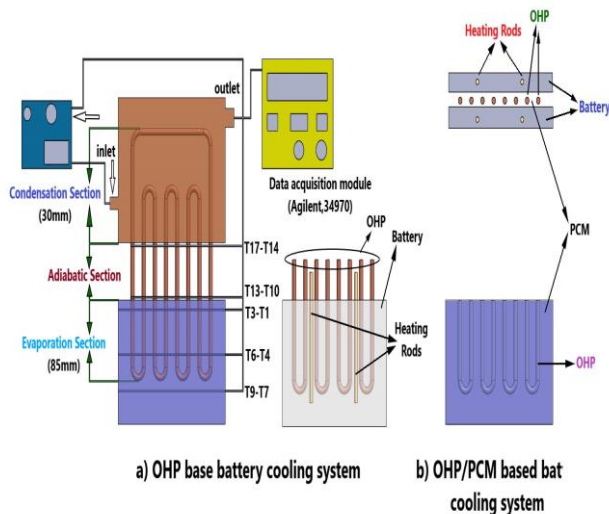
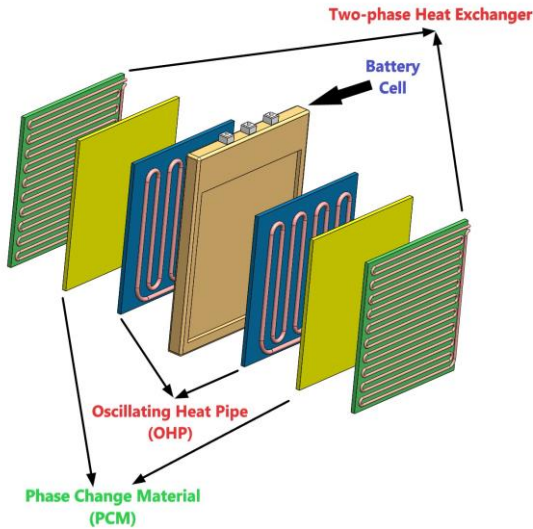

**Fig. 27.**[113](a) Cooling with OHP.  
(b) Cooling with PCM/OHP.

In 2020 Y.-Z. Ling[114] proposed a thermal cooling management system for an electronic device. They have chosen a new model of the leaf-shaped 3D oscillating heat pipe (3D-OHPs) with PCM. They have tested the model with a different operating condition like air velocities, wind direction, filling ratios on oscillating heat pipe. Their experimental results show that electronic device surface temperature can be maintained under 100°C and 35°C lower than air cooling also thermal resistance decreased by 36.3%. They found that the leaf-shaped 3D-OHPs are more effective and can control surface temperature 2°C lower than the traditional oscillating heat pipe. The author said that it was an effective cooling method compared to the traditional cooling method for electronic device cooling. Though the combined system of oscillating heat pipe with PCM is more effective than the traditional

cooling method it is costly and difficult to control. Recently a novel model was proposed by H.S. Lee, J.W. Kim[115]. The model is a combination of three traditional cooling methods which are oscillating heat pipe/direct refrigerant two phase cooling/PCM. This model is also called an integrated phase change heat transfer package (IHP) [115].

**Fig.28.** [115] shows the configuration. Here oscillating heat pipe is directly connected with the cells then the PCM is a sandwich between the oscillating heat pipe and two-phase heat exchanger. The oscillating heat pipe is used to maintain the uniform temperature of the battery cells. They have proposed that this combined system can control the maximum operating temperature, also maximum temperature difference, uniformity of temperature, and also can be very efficient for cooling. Researchers are trying to develop the model more precisely to overcome the upcoming challenges with the high power and fast charging electric vehicles.



**Fig. 28.** Configuration of integrated phase change heat transfer package (IPH) [115].

## 6. FUTURE RESEARCH DIRECTIONS

The future world is looking for a renewable source of energy such as solar, also wind as well as the energy of hydropower plant. These energy sources are used to generate electricity. There is minimum emission of CO<sub>2</sub>, SO<sub>2</sub>, nitrogen compound, and these characteristics make renewable electricity more preferable to apply an alternative of coal, oil base in vehicles. It is need to say the importance of battery in the electric vehicle. The battery induces heat during operation.

The upcoming days will bring high energy density, fast charging, and fast discharging in the battery of electric vehicles. These will induce a high amount of heat. So there needs some more effective thermal management system for battery configuration like cell, module, pack type. Since there already have many traditional batteries thermal management methods but these are not effective for high energy density batteries used in electric vehicles.

Researchers are also trying to combine more than one traditional thermal cooling system to increase thermal efficiency, also focusing on reducing the thermal resistance of the materials. Traditional cooling system likes air cooling, liquid cooling, PCM cooling, direct two-phase refrigerant cooling, heat pipe cooling, oscillating cooling. Researchers are attempting to vary the airflow direction, flow rate, use a different type of liquid in air cooling and liquid cooling, trying to vary the number of pipes, pipe width, 3D orientation in heat pipe cooling, trying to vary materials characteristics of PCM materials.

Researchers are also investing their time and efforts to increase thermal conductivity, decrease the thermal resistance of PCM materials also increase the latent heat of PCM materials. The composite type materials like PCM with other conductive materials increase the conductivity of the PCM material also the efficiency of the combined system increase.

The choice of perfect PCM is also a big part of the thermal management system. PCM should have high latent heat, high thermal conductivity, low thermal resistance, low cost, available and research is going on to achieve the above properties of PCM. There are some issues with cooling materials.

(1) Though the structure has simple configuration when cooling with air, light in weight but less effective (2) though liquid cooling is highly effective, but it requires circulating pump, heavy, energy consumption (3) though PCM cooling gives high efficiency and temperature uniformity, the thermal performance depends on PCM mass, extra equipment needs to cool the PCM. So to improve thermal performance above disadvantages should eliminate to get high efficiency, light-weight, simple in construction, less space.

Researchers are trying to combine more than two traditional systems though it causes complex construction and increased weight but increases thermal efficiency. Recently a novel model was proposed by H.S. Lee, J.W. Kim[115], where a combination of three conventional cooling methods which are oscillating heat pipe/direct refrigerant two phase cooling/PCM. The researchers are trying to maintain high efficiency, low cost, less complex, the low thermal resistance of the cooling materials use in the cooling system. However, it is mandatory to combine existed cooling systems or making some new models to face future challenges. Some combinations should make such as cold-plate/PCM/heat-pipe, direct-two-phase/PCM/heat-pipe. Since the use of nano-particle in a battery, cooling is not familiar but nano-particle can be used in the cooling system. Since the use of conductive nano-particle in cooling liquid can increase the thermal conductivity of the liquid also it will reduce the mass of the system.

The car companies are using different cooling technology for cooling the car batteries to enhance efficiency. **Table.6** shows the different techniques of battery cooling used.

**Table 6** The different cooling techniques applied for battery cooling in different branded EV manufacturer.

Name	Battery	Year	Cooling
Tesla Model S [116] [117]	100 kWh Li-ion	2012	Liquid cooling using glycol-based coolant (50% Sierra Glycol solution, 50% water)
BMW i3[116]	22 kWh	2013	Direct Refrigerant Cooling(use of existing AC system)
Nissan Leaf [118]	60 kWh	2019	Air cooling
Chevrolet Volt [119, 120]	60-kWh lithium-ion battery pack made up of 288 individual cells.	2019	Liquid cooling
Hyundai Kona [121] [122]	64 kWh battery pack consisting of 5 modules, 294 cells, and are wired into 98 cell groups of three cells apiece.	2019	Liquid Cooling
Ford Focus [116]	23 kWh, Li-ion battery	2016	Liquid cooling
Jaguar I-Pace[123]	58-Ah pouch cell. There are 36 modules ( 12 cells in each module and the total number of cells is 432 )	2018	cooling with water (cooling plate ) integrated into the frame
Mahindra e2oPlus[124]	15 kWh Lithium-Ion	2013	Air cooling through iEMS technology
Mercedes-Benz EQC[125]	80 kWh Lithium-Ion	2018	liquid-cooled
Mahindra eVerito[126]	21.2 Lithium Ion	2017	Liquid cooling

Mitsubishi i-MiEV [127]	16 kWh / 58 MJ (Li-ion battery)	2014	Forced air cooling system. Also, cool with the air of the refrigerant from the car's own air conditioning system.
-------------------------	---------------------------------	------	---

## 7. OTHER RECOMMENDATIONS

Future electric vehicle needs a highly effective battery cooling management system that ensures high cooling efficiency. The main concern about cooling design is how to minimize the disadvantage of battery thermal cooling system. Due to the low thermal conductivity, the air cooling system is not widely used. So there needs a high thermal conductive system and a combination of more than one traditional cooling system. Researchers should focus more on liquid cooling and PCM cooling cause of thermal conductivity of the liquid is higher and higher latent heat of PCM. Though the thermal conductivity of PCM is not good as we want it can be made good by adding a conductive compound with the PCM. Researchers should investigate the conductive materials which can maintain the high conductivity of PCM by adding them with PCM. There are different type of paraffin compound which are highly conductive and low cost and it is used as PCM. The thermal conductivity of PCM can increase by adding nanoparticle. There should add many conductive materials like carbon fiber [128], aluminum fins, carbon nanotubes [129], polyurethane foam [130], metal foams, expanded graphite. If the thermal conductivity is increased highly then it could be the most effective cooling system by combining with other cooling systems. The heat pipe cooling is effective but its contact area is small, so if the contact area can be increased and combined with PCM then it could be another alternative as an effective cooling system. To increase the contact area of pipes (heat pipe and oscillating heat pipe) there should use a conductive cold plate. The system with conductive nanoparticle can be very light and high thermal conductive. So more research efforts are needed to investigate nanoparticles [131-134].

## 8. DISCUSSION

The world is facing the challenge of global warming now. Traditional fossil fuels like oil, gasses contribute to greenhouse gas which causes global warming. An electric vehicle can lessen the greenhouse effect as it does not contribute to carbon emission. Therefore, it is environment friendly and highly efficient. The only problem that Li-ion battery faces is heat generation which degrades its performance. So, in this paper, we focused on the existing and future battery thermal cooling systems. We review the research progress of the BTMS of traditional and future cooling systems. Each cooling system has its advantages and disadvantages. Analyzing the cooling systems we see

1. Air cooling system is the simplest, lightweight, safe and reliable. It does not need many components. However, it has lower thermal co-efficient and non-uniformity. So this system cannot be used in high energy vehicles. To achieve high efficiency it's airflow rate has to be increased and also channel size has to be increased. It needs more power consumption and compact design which requires additional hardware, increases cost, and thus brings complexity to the thermal design.
2. The liquid cooling system gives the highest thermal performance because the liquid has a higher heat capacity than air. However, it has a complex layout, the chance of leakage, and additional components that require more space and make it bulky. Proper coolant is needed to choose and more researches are needed on cooling mechanism like mist type cooling, cooling with ammonia, flow boiling technique.
3. PCM cooling has a lot of heat capacity and does not need power consumption. However, its low conductivity and volume expansion during phase change makes it unsuitable. However, integrating with other cooling systems its conductivity increases and gives a better result.
4. The refrigerant cooling system has good uniformity and can be lumped with the existing AC system. However, it is still costly. Research has to make it less consumable power. The system can be enhanced by combining the temperature control system with a flow control system.[13]
5. PCM's low conductivity problem can be eradicated in heat pipe cooling, but it has a low contact area. Oscillating heat pipe and using aluminum is showing a good result. More research efforts are needed to focus on its structure, working medium, runner size and liquid filling capacity. [13]
6. TEC cooling is low power consumption and an environment-friendly cooling system can serve as both heating and cooling. However, it has low efficiency.

- Research efforts are needed to insert high conductive material.
7. Integrating a traditional cooling system with PCM, it gives a better result. Future research is needed to make the system less consuming power and occupying less space.
  8. Battery heating is also important for the optimization of battery in cold weather countries. Few systems can serve as heating, but they are not efficient. So more research efforts are needed to improve the heating system.

The heat absorbed by the cooling systems is in the environment. Research can be made to store the heat and later serve it when needed

## 9. CONCLUSION

EVs already have demonstrated its potentiality in response to climate change and carbon reduction scheme. Batteries have emerged as energy storage device in EVs. For EVs batteries, the key threat is temperature. Since the battery-charging trend is shifting towards fast charging, the new thermal challenges are going to arise in EVs battery pack. Therefore, an efficient thermal management is required to ensure the performance and safety. This paper elaborately discusses the state-of-the-art cooling technologies in the context of advantages and disadvantages. These can be categorised into air cooling system, liquid cooling system, PCM cooling system, heat pipe cooling system and thermoelectric cooling system. Air cooling system is advantageous because of low weight, cost and maintenance. However, it is problematic due to few factors such as compressors, fans. The limitations of air cooling system have been improved via employing liquid cooling. This is also problematic due to indirect contact, extra weight and rugged construction due to inclusion of heat exchanger in cooling system. Addition of refrigerant based two-phase cooling can help to improve the performance. PCM can eliminate the problems of liquid cooling by replacing the pump. However, PCM is confined in academic research and is yet not applied to practical EV application. There is much room to conduct research on PCM and how the thermal conductivity can be increased and how the improved PCM can be applied in commercial EV applications. Heat pipe also can be another alternative solution but it has limitations of creating less contact area interface with the battery. However, heat pipe cooling is so far studied for only prismatic cells and pouch cells. There is much room to conduct research on cylindrical cells.

Upon reviewing various BTMS, it was found that the no detailed study have been found regarding fast charging battery thermal management. Additionally no consistent figure of merits exist due to inhomogeneity of battery type, capacity, dimension and operating conditions. Therefore, a detailed research is needed to formulate new effective BTMS combining either existing technologies or exploiting new material such as nanofluid. Few studies have been found regarding the promise of nanofluid. The challenges are mainly the long-term stability, the choice of appropriate nanoparticles and additional pressure loss due to higher viscosity of fluids. However, there is much room to investigate how the nanofluid can be more stable by adding appropriate surfactants and how parasitic load can be minimized by assessing pressure loss for various combinations and concentrations of nanofluid.

In the future, battery thermal load is expected to rise due to exploiting fast charging and demand of compact cooling system design. Therefore, further investigations are required to assess how battery cell/module/pack behaves in response to fast charging scenario and how an adaptive BTMS can be designed via exploiting computational fluid dynamics modelling to respond the thermal load as per driving requirements.

## REFERENCES

- [1] J. Cen and F. Jiang, "Li-ion power battery temperature control by a battery thermal management and vehicle cabin air conditioning integrated system," *Energy for Sustainable Development*, vol. 57, pp. 141-148, 2020/08/01/ 2020.
- [2] J. Jaguemont, L. Boulon, and Y. Dubé, "A comprehensive review of lithium-ion batteries used in hybrid and electric vehicles at cold temperatures," *Applied Energy*, vol. 164, pp. 99-114, 2016/02/15/ 2016.
- [3] S. Panchal, I. Dincer, M. Agelin-Chaab, R. Fraser, and M. Fowler, "Design and simulation of a lithium-ion battery at large C-rates and varying boundary conditions through heat flux distributions," *Measurement*, vol. 116, pp. 382-390, 2018/02/01/ 2018.
- [4] C. Bibin, M. Vijayaram, V. Suriya, R. Sai Ganesh, and S. Soundarraj, "A review on thermal issues in Li-ion battery and recent advancements in battery thermal management system," *Materials Today: Proceedings*, 2020/04/09/ 2020.
- [5] T. A. Stuart and A. Hande, "HEV battery heating using AC currents," *Journal of Power Sources*, vol. 129, no. 2, pp. 368-378, 2004/04/22/ 2004.
- [6] Y. Azizi and S. M. Sadrameli, "Thermal management of a LiFePO<sub>4</sub> battery pack at high temperature environment using a composite of phase change materials and aluminum wire mesh plates," *Energy Conversion and Management*, vol. 128, pp. 294-302, 2016/11/15/ 2016.
- [7] X. Feng, M. Ouyang, X. Liu, L. Lu, Y. Xia, and X. He, "Thermal runaway mechanism of lithium ion battery for electric vehicles: A review," *Energy Storage Materials*, vol. 10, pp. 246-267, 2018/01/01/ 2018.
- [8] X. Duan and G. F. Naterer, "Heat transfer in phase change materials for thermal management of electric vehicle battery modules," *International Journal of Heat and Mass Transfer*, vol. 53, no. 23, pp. 5176-5182, 2010/11/01/ 2010.

- [9] H. C. Shiao, D. Chua, H.-p. Lin, S. Slane, and M. Salomon, "Low temperature electrolytes for Li-ion PVDF cells," *Journal of Power Sources*, vol. 87, no. 1, pp. 167-173, 2000/04/01/ 2000.
- [10] T. M. Bandhauer, S. Garimella, and T. F. Fuller, "A Critical Review of Thermal Issues in Lithium-Ion Batteries," *Journal of The Electrochemical Society*, vol. 158, no. 3, p. R1, 2011.
- [11] Q. Wang, B. Jiang, B. Li, and Y. Yan, "A critical review of thermal management models and solutions of lithium-ion batteries for the development of pure electric vehicles," *Renewable and Sustainable Energy Reviews*, vol. 64, pp. 106-128, 2016/10/01/ 2016.
- [12] Z. Rao and S. Wang, "A review of power battery thermal energy management," *Renewable and Sustainable Energy Reviews*, vol. 15, no. 9, pp. 4554-4571, 2011/12/01/ 2011.
- [13] J. Kim, J. Oh, and H. Lee, "Review on Battery Thermal Management System for Electric Vehicles," *Applied Thermal Engineering*, vol. 149, 12/01 2018.
- [14] M. Lu, X. Zhang, J. Ji, X. Xu, and Y. Zhang, "Research progress on power battery cooling technology for electric vehicles," *Journal of Energy Storage*, vol. 27, p. 101155, 2020/02/01/ 2020.
- [15] J. Jaguemont and J. Van Mierlo, "A comprehensive review of future thermal management systems for battery-electrified vehicles," *Journal of Energy Storage*, vol. 31, p. 101551, 2020/10/01/ 2020.
- [16] H. Sun and R. Dixon, "Development of cooling strategy for an air cooled lithium-ion battery pack," *Journal of Power Sources*, vol. 272, pp. 404-414, 2014/12/25/ 2014.
- [17] A. Karthik, P. Kalita, X. Cui, and X. Peng, "Thermal management for prevention of failures of Lithium ion battery packs in electric vehicles: A review and critical future aspects," *Energy Storage*, p. e137, 02/05 2020.
- [18] Y. Deng *et al.*, "Effects of different coolants and cooling strategies on the cooling performance of the power lithium ion battery system: A review," *Applied Thermal Engineering*, vol. 142, pp. 10-29, 2018/09/01/ 2018.
- [19] A. Pesaran, "Battery Thermal Management in EVs and HEVs: Issues and Solutions," *Battery Man*, vol. 43, 01/01 2001.
- [20] H. Wang, T. Tao, J. Xu, X. Mei, X. Liu, and P. Gou, "Cooling capacity of a novel modular liquid-cooled battery thermal management system for cylindrical lithium ion batteries," *Applied Thermal Engineering*, vol. 178, p. 115591, 2020/09/01/ 2020.
- [21] Y. Lai, W. Wu, K. Chen, S. Wang, and C. Xin, "A compact and lightweight liquid-cooled thermal management solution for cylindrical lithium-ion power battery pack," *International Journal of Heat and Mass Transfer*, vol. 144, p. 118581, 2019/12/01/ 2019.
- [22] G. Karimi and X. Li, "Thermal management of lithium-ion batteries for electric vehicles," *International Journal of Energy Research*, vol. 37, 01/01 2013.
- [23] C. Xiao, G. Zhang, Z. Li, and X. J. J. o. M. C. A. Yang, "Custom design of solid–solid phase change material with ultra-high thermal stability for battery thermal management," vol. 8, no. 29, pp. 14624-14633, 2020.
- [24] Y. Lv, X. Yang, X. Li, G. Zhang, Z. Wang, and C. Yang, "Experimental study on a novel battery thermal management technology based on low density polyethylene-enhanced composite phase change materials coupled with low fins," *Applied Energy*, vol. 178, pp. 376-382, 2016/09/15/ 2016.
- [25] T. Yan, R. Z. Wang, T. X. Li, L. W. Wang, and I. T. Fred, "A review of promising candidate reactions for chemical heat storage," *Renewable and Sustainable Energy Reviews*, vol. 43, pp. 13-31, 2015/03/01/ 2015.
- [26] T. Gürmen, "Preparation, Characterization and Thermal Properties of Paraffin Wax – Expanded Perlite Form-Stable Composites for Latent Heat Storage," *Materials Science*, vol. 23, 02/09 2017.
- [27] L. H. Saw, Y. Ye, M. C. Yew, W. T. Chong, M. K. Yew, and T. C. Ng, "Computational fluid dynamics simulation on open cell aluminium foams for Li-ion battery cooling system," *Applied Energy*, vol. 204, pp. 1489-1499, 2017/10/15/ 2017.
- [28] A. Verma, S. Shashidhara, and D. Rakshit, "A comparative study on battery thermal management using phase change material (PCM)," *Thermal Science and Engineering Progress*, vol. 11, pp. 74-83, 2019/06/01/ 2019.
- [29] P. Ping, R. Peng, D. Kong, G. Chen, and J. Wen, "Investigation on thermal management performance of PCM-fin structure for Li-ion battery module in high-temperature environment," *Energy Conversion and Management*, vol. 176, pp. 131-146, 2018/11/15/ 2018.
- [30] J. Cen, Z. Li, and F. Jiang, "Experimental investigation on using the electric vehicle air conditioning system for lithium-ion battery thermal management," *Energy for Sustainable Development*, vol. 45, pp. 88-95, 2018/08/01/ 2018.
- [31] P. Kritzer, D. J. A. i. C. E. Harry, and Science, "Improved safety for automotive lithium batteries: an innovative approach to include an emergency cooling element," vol. 2014, 2014.
- [32] Y. Wang, Q. Gao, G. Wang, P. Lu, M. Zhao, and W. Bao, "A review on research status and key technologies of battery thermal management and its enhanced safety," *International Journal of Energy Research*, vol. 42, no. 13, pp. 4008-4033, 2018/10/25 2018.
- [33] B. Ariantara, N. Putra, and S. Supriadi, "Battery thermal management system using loop heat pipe with LTP copper capillary wick," in *IOP Conference Series: Earth and Environmental Science*, 2018: IOP Publishing.
- [34] H. Jouhara, N. Serey, N. Khordeghah, R. Bennett, S. Almahmoud, and S. P. Lester, "Investigation, development and experimental analyses of a heat pipe based battery thermal management system," *International Journal of Thermofluids*, vol. 1-2, p. 100004, 2020/02/01/ 2020.
- [35] Y. Gan, L. He, J. Liang, M. Tan, T. Xiong, and Y. Li, "A numerical study on the performance of a thermal management system for a battery pack with cylindrical cells based on heat pipes," *Applied Thermal Engineering*, vol. 179, p. 115740, 2020/10/01/ 2020.
- [36] T.-H. Tran, S. Harmand, B. Desmet, and S. Filangi, "Experimental investigation on the feasibility of heat pipe cooling for HEV/EV lithium-ion battery," *Applied Thermal Engineering*, vol. 63, no. 2, pp. 551-558, 2014/02/22/ 2014.
- [37] R.-G. Chi and S.-H. Rhi, "Oscillating Heat Pipe Cooling System of Electric Vehicle's Li-Ion Batteries with Direct Contact Bottom Cooling Mode," *Energies*, vol. 12, p. 1698, 05/05 2019.
- [38] Y. Lyu, A. R. M. Siddique, S. H. Majid, M. Biglarbegian, S. A. Gadsden, and S. Mahmud, "Electric vehicle battery thermal management system with thermoelectric cooling," *Energy Reports*, vol. 5, pp. 822-827, 2019/11/01/ 2019.
- [39] S. Arora, "Selection of thermal management system for modular battery packs of electric vehicles: A review of existing and emerging technologies," *Journal of Power Sources*, vol. 400, pp. 621-640, 2018/10/01/ 2018.
- [40] C. Qiu and W. Shi, "Comprehensive modeling for optimized design of a thermoelectric cooler with non-constant cross-section: Theoretical considerations," *Applied Thermal Engineering*, vol. 176, p. 115384, 2020/07/25/ 2020.
- [41] C. Selvam, S. Manikandan, N. V. Krishna, R. Lamba, S. C. Kaushik, and O. Mahian, "Enhanced thermal performance of a thermoelectric generator with phase change materials," *International Communications in Heat and Mass Transfer*, vol. 114, p. 104561, 2020/05/01/ 2020.
- [42] J. Li and Z. Zhu, "Battery thermal management systems of electric vehicles," 2014.
- [43] Y. Wei and M. Agelin-Chaab, "Experimental investigation of a novel hybrid cooling method for lithium-ion batteries," *Applied Thermal Engineering*, vol. 136, pp. 375-387, 2018/05/25/ 2018.
- [44] T. Yamada, T. Koshiyama, M. Yoshikawa, T. Yamada, N. J. J. o. T. S. Ono, and Technology, "Analysis of a lithium-ion battery cooling system for electric vehicles using a phase-change material and heat pipes," vol. 12, no. 1, pp. JTST0011-JTST0011, 2017.
- [45] C. Wang *et al.*, "Liquid cooling based on thermal silica plate for battery thermal management system," vol. 41, pp. 2468-2479, 2017.
- [46] W. Wu, W. Wu, and S. Wang, "Thermal management optimization of a prismatic battery with shape-stabilized phase change material," *International Journal of Heat and Mass Transfer*, vol. 121, pp. 967-977, 2018/06/01/ 2018.
- [47] D. Chen, J. Jiang, G.-H. Kim, C. Yang, and A. Pesaran, "Comparison of different cooling methods for lithium ion battery cells," *Applied Thermal Engineering*, vol. 94, pp. 846-854, 2016/02/05/ 2016.



- [48] S. Panchal, R. Khasow, I. Dincer, M. Agelin-Chaab, R. Fraser, and M. Fowler, "Thermal design and simulation of mini-channel cold plate for water cooled large sized prismatic lithium-ion battery," *Applied Thermal Engineering*, vol. 122, pp. 80-90, 2017/07/25/ 2017.
- [49] "The Composition of EV Batteries: Cells? Modules? Packs? Let's Understand Properly!"
- [50] T. Wang, K. J. Tseng, J. Zhao, and Z. Wei, "Thermal investigation of lithium-ion battery module with different cell arrangement structures and forced air-cooling strategies," *Applied Energy*, vol. 134, pp. 229-238, 2014/12/01/ 2014.
- [51] L. Fan, J. Khodadadi, and A. J. J. o. P. S. Pesaran, "A parametric study on thermal management of an air-cooled lithium-ion battery module for plug-in hybrid electric vehicles," vol. 238, pp. 301-312, 2013.
- [52] Z. An, L. Jia, Y. Ding, C. Dang, and X. J. J. o. T. S. Li, "A review on lithium-ion power battery thermal management technologies and thermal safety," vol. 26, no. 5, pp. 391-412, 2017.
- [53] J. Kim, J. Oh, and H. Lee, "Review on battery thermal management system for electric vehicles," *Applied Thermal Engineering*, vol. 149, pp. 192-212, 2019/02/25/ 2019.
- [54] N. Sato, "Thermal behavior analysis of lithium-ion batteries for electric and hybrid vehicles," *Journal of Power Sources*, vol. 99, no. 1, pp. 70-77, 2001/08/01/ 2001.
- [55] C.-Y. Jhu, Y.-W. Wang, C.-Y. Wen, and C.-M. Shu, "Thermal runaway potential of LiCoO<sub>2</sub> and Li(Ni<sub>1/3</sub>Co<sub>1/3</sub>Mn<sub>1/3</sub>)O<sub>2</sub> batteries determined with adiabatic calorimetry methodology," *Applied Energy*, vol. 100, pp. 127-131, 2012/12/01/ 2012.
- [56] S. S. Y. Ng, Y. Xing, and K. L. Tsui, "A naive Bayes model for robust remaining useful life prediction of lithium-ion battery," *Applied Energy*, vol. 118, pp. 114-123, 2014/04/01/ 2014.
- [57] P. Ping, Q. Wang, P. Huang, J. Sun, and C. Chen, "Thermal behaviour analysis of lithium-ion battery at elevated temperature using deconvolution method," *Applied Energy*, vol. 129, pp. 261-273, 2014/09/15/ 2014.
- [58] R. Mahamud and C. Park, "Reciprocating air flow for Li-ion battery thermal management to improve temperature uniformity," *Journal of Power Sources*, vol. 196, no. 13, pp. 5685-5696, 2011/07/01/ 2011.
- [59] J. Zhao, Z. Rao, Y. Huo, X. Liu, and Y. Li, "Thermal management of cylindrical power battery module for extending the life of new energy electric vehicles," *Applied Thermal Engineering*, vol. 85, pp. 33-43, 2015/06/25/ 2015.
- [60] N. Lewchalermwong, M. Masomtob, V. Lailuck, and C. Charoenphonphanich, "Material selection and assembly method of battery pack for compact electric vehicle," *IOP Conference Series: Materials Science and Engineering*, vol. 297, p. 012019, 2018/01 2018.
- [61] S. Park and D. Jung, "Battery cell arrangement and heat transfer fluid effects on the parasitic power consumption and the cell temperature distribution in a hybrid electric vehicle," *Journal of Power Sources*, vol. 227, pp. 191-198, 2013/04/01/ 2013.
- [62] A. Jarrett and I. Y. Kim, "Design optimization of electric vehicle battery cooling plates for thermal performance," *Journal of Power Sources*, vol. 196, no. 23, pp. 10359-10368, 2011/12/01/ 2011.
- [63] A. Jarrett and I. Y. Kim, "Influence of operating conditions on the optimum design of electric vehicle battery cooling plates," *Journal of Power Sources*, vol. 245, pp. 644-655, 2014/01/01/ 2014.
- [64] Z. Ling *et al.*, "Experimental and numerical investigation of the application of phase change materials in a simulative power batteries thermal management system," *Applied Energy*, vol. 121, pp. 104-113, 2014/05/15/ 2014.
- [65] Z. Ling, F. Wang, X. Fang, X. Gao, and Z. Zhang, "A hybrid thermal management system for lithium ion batteries combining phase change materials with forced-air cooling," *Applied Energy*, vol. 148, pp. 403-409, 2015/06/15/ 2015.
- [66] K. Somasundaram, E. Birgersson, and A. S. Mujumdar, "Thermal-electrochemical model for passive thermal management of a spiral-wound lithium-ion battery," *Journal of Power Sources*, vol. 203, pp. 84-96, 2012/04/01/ 2012.
- [67] M.-S. Wu, K. H. Liu, Y.-Y. Wang, and C.-C. Wan, "Heat dissipation design for lithium-ion batteries," *Journal of Power Sources*, vol. 109, no. 1, pp. 160-166, 2002/06/15/ 2002.
- [68] T. Wang, K. J. Tseng, and J. Zhao, "Development of efficient air-cooling strategies for lithium-ion battery module based on empirical heat source model," *Applied Thermal Engineering*, vol. 90, pp. 521-529, 2015/11/05/ 2015.
- [69] S. K. Mohammadian and Y. Zhang, "Thermal management optimization of an air-cooled Li-ion battery module using pin-fin heat sinks for hybrid electric vehicles," *Journal of Power Sources*, vol. 273, pp. 431-439, 2015/01/01/ 2015.
- [70] J. Xie, Z. Ge, M. Zang, and S. Wang, "Structural optimization of lithium-ion battery pack with forced air cooling system," *Applied Thermal Engineering*, vol. 126, pp. 583-593, 2017/11/05/ 2017.
- [71] K. Chen, S. Wang, M. Song, and L. Chen, "Structure optimization of parallel air-cooled battery thermal management system," *International Journal of Heat and Mass Transfer*, vol. 111, pp. 943-952, 2017/08/01/ 2017.
- [72] S. Hong, X. Zhang, K. Chen, and S. Wang, "Design of flow configuration for parallel air-cooled battery thermal management system with secondary vent," *International Journal of Heat and Mass Transfer*, vol. 116, pp. 1204-1212, 2018/01/01/ 2018.
- [73] X. Ye, Y. Zhao, and Z. Quan, "Experimental study on heat dissipation for lithium-ion battery based on micro heat pipe array (MHPA)," *Applied Thermal Engineering*, vol. 130, pp. 74-82, 2018/02/05/ 2018.
- [74] L. Feng *et al.*, "Experimental investigation of thermal and strain management for lithium-ion battery pack in heat pipe cooling," *Journal of Energy Storage*, vol. 16, pp. 84-92, 2018/04/01/ 2018.
- [75] J. Cao, M. Luo, X. Fang, Z. Ling, and Z. Zhang, "Liquid cooling with phase change materials for cylindrical Li-ion batteries: An experimental and numerical study," *Energy*, vol. 191, p. 116565, 2020/01/15/ 2020.
- [76] H. Zhang, C. Li, R. Zhang, Y. Lin, and H. Fang, "Thermal analysis of a 6s4p Lithium-ion battery pack cooled by cold plates based on a multi-domain modeling framework," *Applied Thermal Engineering*, vol. 173, p. 115216, 2020/06/05/ 2020.
- [77] T. M. Bandhauer, S. Garimella, and T. F. J. J. o. t. E. S. Fuller, "A critical review of thermal issues in lithium-ion batteries," vol. 158, no. 3, p. R1, 2011.
- [78] J. Jaguemont *et al.*, "1D-Thermal Analysis and Electro-Thermal Modeling of Prismatic-Shape LTO and NMC Batteries," in *2019 IEEE Vehicle Power and Propulsion Conference (VPPC)*, 2019, pp. 1-5.
- [79] B. Y. Liaw, R. G. Jungst, G. Nagasubramanian, H. L. Case, and D. H. Doughty, "Modeling capacity fade in lithium-ion cells," *Journal of Power Sources*, vol. 140, no. 1, pp. 157-161, 2005/01/10/ 2005.
- [80] A. Samba *et al.*, "Development of an Advanced Two-Dimensional Thermal Model for Large size Lithium-ion Pouch Cells," *Electrochimica Acta*, vol. 117, pp. 246-254, 2014/01/20/ 2014.
- [81] J. Gou and W. Liu, "Feasibility study on a novel 3D vapor chamber used for Li-ion battery thermal management system of electric vehicle," *Applied Thermal Engineering*, vol. 152, pp. 362-369, 2019/04/01/ 2019.
- [82] W. M. Budzianowski, "Negative carbon intensity of renewable energy technologies involving biomass or carbon dioxide as inputs," *Renewable and Sustainable Energy Reviews*, vol. 16, no. 9, pp. 6507-6521, 2012/12/01/ 2012.
- [83] N. Sulaiman, M. A. Hannan, A. Mohamed, E. H. Majlan, and W. R. Wan Daud, "A review on energy management system for fuel cell hybrid electric vehicle: Issues and challenges," *Renewable and Sustainable Energy Reviews*, vol. 52, pp. 802-814, 2015/12/01/ 2015.
- [84] F. Herrmann and F. Rothfuss, "1 - Introduction to hybrid electric vehicles, battery electric vehicles, and off-road electric vehicles," in *Advances in Battery Technologies for Electric Vehicles*, B. Scrosati, J. Garche, and W. Tillmetz, Eds.: Woodhead Publishing, 2015, pp. 3-16.
- [85] H. Shareef, M. M. Islam, and A. Mohamed, "A review of the stage-of-the-art charging technologies, placement methodologies, and impacts of electric vehicles," *Renewable and Sustainable Energy Reviews*, vol. 64, pp. 403-420, 2016/10/01/ 2016.

- [86] J. Y. Yong, V. K. Ramachandaramurthy, K. M. Tan, and N. Mithulananthan, "A review on the state-of-the-art technologies of electric vehicle, its impacts and prospects," *Renewable and Sustainable Energy Reviews*, vol. 49, pp. 365-385, 2015/09/01/ 2015.
- [87] L. H. Saw, Y. Ye, and A. A. O. Tay, "Integration issues of lithium-ion battery into electric vehicles battery pack," *Journal of Cleaner Production*, vol. 113, pp. 1032-1045, 2016/02/01/ 2016.
- [88] Z. Rao, S. Wang, and G. Zhang, "Simulation and experiment of thermal energy management with phase change material for ageing LiFePO<sub>4</sub> power battery," *Energy Conversion and Management*, vol. 52, no. 12, pp. 3408-3414, 2011/11/01/ 2011.
- [89] L. Lu, X. Han, J. Li, J. Hua, and M. Ouyang, "A review on the key issues for lithium-ion battery management in electric vehicles," *Journal of Power Sources*, vol. 226, pp. 272-288, 2013/03/15/ 2013.
- [90] J. Speirs, M. Contestabile, Y. Houari, and R. Gross, "The future of lithium availability for electric vehicle batteries," *Renewable and Sustainable Energy Reviews*, vol. 35, pp. 183-193, 2014/07/01/ 2014.
- [91] X. Han *et al.*, "A review on the key issues of the lithium ion battery degradation among the whole life cycle," *eTransportation*, vol. 1, p. 100005, 2019/08/01/ 2019.
- [92] C. Birkel, M. Roberts, E. McTurk, P. Bruce, and D. Howey, "Degradation diagnostics for lithium ion cells," *Journal of Power Sources*, vol. 341, pp. 373-386, 02/01 2017.
- [93] C. R. Birkel, M. R. Roberts, E. McTurk, P. G. Bruce, and D. A. J. J. o. P. S. Howey, "Degradation diagnostics for lithium ion cells," vol. 341, pp. 373-386, 2017.
- [94] B. Lawson. (2005). *Lithium Battery Failures*. Available: [https://www.mpoweruk.com/lithium\\_failures.htm?fbclid=IwAR0MQB7JCh9kI8BOJF\\_ur7ouJg-2QC-C7Sr2BJN6G5rZk4GtmlUpWunmz5Mhttps://www.mpoweruk.com/lithium\\_failures.htm?fbclid=IwAR0MQB7JCh9kI8BOJF\\_ur7ouJg-2QC-C7Sr2BJN6G5rZk4GtmlUpWunmz5M](https://www.mpoweruk.com/lithium_failures.htm?fbclid=IwAR0MQB7JCh9kI8BOJF_ur7ouJg-2QC-C7Sr2BJN6G5rZk4GtmlUpWunmz5Mhttps://www.mpoweruk.com/lithium_failures.htm?fbclid=IwAR0MQB7JCh9kI8BOJF_ur7ouJg-2QC-C7Sr2BJN6G5rZk4GtmlUpWunmz5M)
- [95] G. Ning, B. Haran, and B. N. Popov, "Capacity fade study of lithium-ion batteries cycled at high discharge rates," *Journal of Power Sources*, vol. 117, no. 1, pp. 160-169, 2003/05/15/ 2003.
- [96] J. Vetter *et al.*, "Ageing mechanisms in lithium-ion batteries," *Journal of Power Sources*, vol. 147, no. 1, pp. 269-281, 2005/09/09/ 2005.
- [97] F. Leng, C. Tan, and M. Pecht, "Effect of Temperature on the Aging rate of Li Ion Battery Operating above Room Temperature," *Scientific reports*, vol. 5, p. 12967, 08/06 2015.
- [98] T. Waldmann, M. Wilka, M. Kasper, M. Fleischhammer, and M. Wohlfahrt-Mehrens, "Temperature dependent ageing mechanisms in Lithium-ion batteries – A Post-Mortem study," *Journal of Power Sources*, vol. 262, pp. 129–135, 09/01 2014.
- [99] F. Chen *et al.*, "Air and PCM cooling for battery thermal management considering battery cycle life," *Applied Thermal Engineering*, vol. 173, p. 115154, 2020/06/05/ 2020.
- [100] Z. Ling, W. Lin, Z. Zhang, and X. Fang, "Computationally efficient thermal network model and its application in optimization of battery thermal management system with phase change materials and long-term performance assessment," *Applied Energy*, vol. 259, p. 114120, 2020/02/01/ 2020.
- [101] J. Neubauer and E. Wood, "Thru-life impacts of driver aggression, climate, cabin thermal management, and battery thermal management on battery electric vehicle utility," *Journal of Power Sources*, vol. 259, pp. 262-275, 2014/08/01/ 2014.
- [102] B. Scrosati and J. Garche, "Lithium Batteries: Status, Prospects and Future," *Journal of Power Sources*, vol. 195, pp. 2419-2430, 05/01 2010.
- [103] N. Nitta, F. Wu, J. Lee, and G. Yushin, "Li ion Battery Materials: Present and Future," *Materials Today*, vol. 18, 11/01 2014.
- [104] A. Wang, S. Kadam, H. Li, S. Shi, and Y. Qi, "Review on modeling of the anode solid electrolyte interphase (SEI) for lithium-ion batteries," *npj Computational Materials*, vol. 4, no. 1, p. 15, 2018/03/26 2018.
- [105] X. Shen *et al.*, "Research progress on silicon/carbon composite anode materials for lithium-ion battery," *Journal of Energy Chemistry*, vol. 27, 12/01 2017.
- [106] J. C. Burns, D. A. Stevens, and J. R. Dahn, "In-Situ Detection of Lithium Plating Using High Precision Coulometry," *Journal of The Electrochemical Society*, vol. 162, no. 6, pp. A959-A964, 2015.
- [107] H. Fathabadi, "High thermal performance lithium-ion battery pack including hybrid active-passive thermal management system for using in hybrid/electric vehicles," *Energy*, vol. 70, pp. 529-538, 2014/06/01/ 2014.
- [108] Y. Zheng, Y. Shi, and Y. Huang, "Optimisation with adiabatic interlayers for liquid-dominated cooling system on fast charging battery packs," *Applied Thermal Engineering*, vol. 147, pp. 636-646, 2019/01/25/ 2019.
- [109] Y. Zhao, B. Zou, C. Li, and Y. J. E. P. Ding, "Active cooling based battery thermal management using composite phase change materials," vol. 158, pp. 4933-4940, 2019.
- [110] J. Zhao, P. Lv, and Z. Rao, "Experimental study on the thermal management performance of phase change material coupled with heat pipe for cylindrical power battery pack," *Experimental Thermal and Fluid Science*, vol. 82, pp. 182-188, 2017/04/01/ 2017.
- [111] W. Zhang, J. Qiu, X. Yin, and D. Wang, "A novel heat pipe assisted separation type battery thermal management system based on phase change material," *Applied Thermal Engineering*, vol. 165, p. 114571, 2020/01/25/ 2020.
- [112] N. Putra, A. F. Sandi, B. Ariantara, N. Abdullah, and T. M. Indra Mahlia, "Performance of beeswax phase change material (PCM) and heat pipe as passive battery cooling system for electric vehicles," *Case Studies in Thermal Engineering*, vol. 21, p. 100655, 2020/10/01/ 2020.
- [113] Q. Wang, Z. Rao, Y. Huo, and S. Wang, "Thermal performance of phase change material/oscillating heat pipe-based battery thermal management system," *International Journal of Thermal Sciences*, vol. 102, pp. 9-16, 2016/04/01/ 2016.
- [114] Y.-Z. Ling, X.-S. Zhang, F. Wang, and X.-H. She, "Performance study of phase change materials coupled with three-dimensional oscillating heat pipes with different structures for electronic cooling," *Renewable Energy*, vol. 154, pp. 636-649, 2020/07/01/ 2020.
- [115] J. Kim, J. Oh, and H. J. A. t. e. Lee, "Review on battery thermal management system for electric vehicles," vol. 149, pp. 192-212, 2019.
- [116] J. Zhu. (2015, 11th October, 23th August). *Summary Of Electric Vehicle Battery Cooling Systems*. Available: <https://jingweizhu.weebly.com/blog/summary-of-electric-vehicle-battery-cooling-systems>
- [117] Wikipedia, "Tesla Model S," *Wikipedia, The Free Encyclopedia*, 17 August 2020.
- [118] D. M. Holland. (December 5th, 2018, 23th August). *2019 Nissan LEAF — Still No Liquid-Cooled Battery?* Available: <https://cleantechnica.com/2018/12/05/60-kwh-nissan-leaf-still-no-liquid-cooled-battery/>
- [119] J. VOELCKER, "How Chevy's Volt keeps its cool," 23th July 2010.
- [120] D. Takahashi, 23 September 2019.
- [121] J. VOELCKER, "5 things about the 2019 Hyundai Kona Electric we learned at the NY auto show," APRIL 4, 2018.
- [122] J. Perry, "Details emerge about battery thermal management on new Hyundai Kona EV," January 2019.
- [123] A. T. Review. (2018). Available: <https://autotechreview.com/technology/propulsion-system-of-the-new-jaguar-i-pace>
- [124] mahindraelectric.com. (2013). Available: <https://www.mahindraelectric.com/vehicles/e2oPlus/>
- [125] insideevs.com, "Here we present a more technical view of the Mercedes-Benz EQC," 2018.
- [126] <https://www.mahindraelectric.com/> "SILENT, SMOOTH & SUAVE. INDIA'S FIRST ELECTRIC SEDAN!," january,2017.
- [127] Wikipedia. (2014). *Mitsubishi i-MiEV*. Available: [https://en.wikipedia.org/wiki/Mitsubishi\\_i-MiEV](https://en.wikipedia.org/wiki/Mitsubishi_i-MiEV)
- [128] F. Samimi, A. Babapoor, M. Azizi, and G. Karimi, "Thermal management analysis of a Li-ion battery cell using phase change material loaded with carbon fibers," *Energy*, vol. 96, pp. 355-371, 2016/02/01/ 2016.

- [129] A. H. N. Shirazi, F. Mohebbi, M. R. Azadi Kakavand, B. He, and T. Rabczuk, "Paraffin Nanocomposites for Heat Management of Lithium-Ion Batteries: A Computational Investigation," *Journal of Nanomaterials*, vol. 2016, p. 2131946, 2016/03/16 2016.
- [130] N. Javani, I. Dincer, G. F. Naterer, and G. L. Rohrauer, "Modeling of passive thermal management for electric vehicle battery packs with PCM between cells," *Applied Thermal Engineering*, vol. 73, no. 1, pp. 307-316, 2014/12/05/ 2014.
- [131] D. Han, B. Guene Lougou, Y. Xu, Y. Shuai, and X. Huang, "Thermal properties characterization of chloride salts/nanoparticles composite phase change material for high-temperature thermal energy storage," *Applied Energy*, vol. 264, p. 114674, 2020/04/15/ 2020.
- [132] P. D. Myers, T. E. Alam, R. Kamal, D. Y. Goswami, and E. Stefanakos, "Nitrate salts doped with CuO nanoparticles for thermal energy storage with improved heat transfer," *Applied Energy*, vol. 165, pp. 225-233, 2016/03/01/ 2016.
- [133] H. Tian, L. Du, X. Wei, S. Deng, W. Wang, and J. Ding, "Enhanced thermal conductivity of ternary carbonate salt phase change material with Mg particles for solar thermal energy storage," *Applied Energy*, vol. 204, pp. 525-530, 2017/10/15/ 2017.
- [134] G. Mohan, M. Venkataraman, J. Gomez-Vidal, and J. Coventry, "Assessment of a novel ternary eutectic chloride salt for next generation high-temperature sensible heat storage," *Energy Conversion and Management*, vol. 167, pp. 156-164, 2018/07/01/ 2018.