

# Northumbria Research Link

Citation: Mahamedi, Elham, Rogage, Kay, Doukari, Omar and Kassem, Mohamad (2021) Automating equipment productivity measurement using deep learning. In: Proceedings of the 2021 European Conference on Computing in Construction. Computing in Construction, 2 . University College Dublin, Dublin, pp. 140-147. ISBN 9783907234549

Published by: University College Dublin

URL: <https://doi.org/10.35490/ec3.2021.153> <<https://doi.org/10.35490/ec3.2021.153>>

This version was downloaded from Northumbria Research Link:  
<http://nrl.northumbria.ac.uk/id/eprint/48886/>

Northumbria University has developed Northumbria Research Link (NRL) to enable users to access the University's research output. Copyright © and moral rights for items on NRL are retained by the individual author(s) and/or other copyright owners. Single copies of full items can be reproduced, displayed or performed, and given to third parties in any format or medium for personal research or study, educational, or not-for-profit purposes without prior permission or charge, provided the authors, title and full bibliographic details are given, as well as a hyperlink and/or URL to the original metadata page. The content must not be changed in any way. Full items must not be sold commercially in any format or medium without formal permission of the copyright holder. The full policy is available online: <http://nrl.northumbria.ac.uk/policies.html>

This document may differ from the final, published version of the research and has been made available online in accordance with publisher policies. To read and/or cite from the published version of the research, please visit the publisher's website (a subscription may be required.)



## AUTOMATING EQUIPMENT PRODUCTIVITY MEASUREMENT USING DEEP LEARNING

Elham Mahamedi<sup>1</sup>, Kay Rogage<sup>2</sup>, Omar Doukari<sup>1</sup>, and Mohamad Kassem<sup>1</sup>

<sup>1</sup>Department of Mechanical & Construction Engineering,

<sup>2</sup>Department of Computer and Information Sciences,

Northumbria University, Newcastle-Upon-Tyne, NE1 8ST, UK

### **ABSTRACT**

Site equipment represent a major cost element in construction projects. Measuring equipment productivity help to identify equipment inefficiencies and improve their productivity; however, measurement processes are time and resource intensive. Current literature has focused on automating equipment activity capture but still lack adequate approaches for measurement of equipment productivity rates. Our contribution is to present a methodology for automating equipment productivity measurement using kinematic and noise data collected through smartphone sensors from within equipment and deep learning algorithms for recognizing equipment states. The testing of the proposed method in a real world case study demonstrated very high accuracy of 99.78% in measuring productivity of an excavator.

### **INTRODUCTION**

Equipment productivity is a factor that affects the success of construction projects, particularly equipment-intensive projects such as earth-moving, pavement and tunnel projects. Construction equipment productivity has been studied by many researchers (Ok and Sinha, 2006, Gurm and Aibinu, 2017) and (Gerami Seresht and Fayek, 2018)) to improve the overall construction productivity and reduce project time and cost. To improve productivity, it must be measured and monitored throughout the project execution phase to identify equipment inefficiencies and their root causes. However, collecting the required data for equipment performance monitoring is time and resource consuming (Chen et al., 2020). Manual data collection particularly, is error prone and impracticable in large projects (Kim et al., 2018). This demonstrates the need for automating the process of equipment data collection, measuring and benchmarking their productivity, and monitoring their performance in large construction projects.

The recent advancement in the equipment technology can provide some useful information about different aspects of the equipment performance. However, many companies still use the equipment without such technologies and need to adopt other methods for monitoring their equipment performance. The aim of this paper is to propose a method for automating the collection

of key data about equipment operation and the measurement of their productivity using low-cost smartphone sensors and deep learning techniques. This paper first outlines the equipment productivity metrics from the usage time aspect. Then, the studies related to automating equipment activity recognition and productivity measurement are described. In the next sections, the proposed methodology is presented and demonstrated in a real case study. Then, discussions on the research findings, limitations and future work along with the conclusion are provided in the last sections.

### **EQUIPMENT PRODUCTIVITY METRICS**

Productivity is generally defined as the ratio of output over input. Different metrics have been proposed to measure equipment productivity and evaluate efficiency of equipment usage. For instance, some metrics have accounted for downtime for evaluating equipment productivity. Vorster and De La Garza (1990) defined the downtime ratio ( $Z$ ) for equipment over a month, as shown in Equation (1):

$$Z(\%) = \frac{D}{D + W} \times 100 \quad (1)$$

where  $D$  is the number of hours a particular equipment unit is broken down in a month, and  $W$  is the total number of hours worked by the equipment in the month.

Nepal and Park (2004) defined equipment downtime ( $DT$ ) ratio as follows:

$$DT(\%) = \frac{\text{Total DT hours}}{\text{Total planned working hours}} \times 100 \quad (2)$$

Equipment availability is another metric, which accounts for the percentage of time that an equipment unit is available for operation, but it can be measured out of 24 hours, or out of the shift time that the equipment was scheduled to operate as proposed by (Ibbs Jr and Terveer, 1984) in Equation (3) for the utilization ratio ( $UR$ ):

$$UR(\%) = \frac{\text{Total working time}}{\text{Total available time}} \times 100 \quad (3)$$

By measuring such metrics for different types of equipment, productivity benchmarks can be produced and used for project monitoring to identify underperforming

equipment. Then, the issues causing underperformance of equipment can be investigated and addressed to improve their productivity.

## **RELATED STUDIES**

Several studies have been carried out to recognize equipment activities, determine their activity duration, and identify their operation cycle time through automated data capture. Montaser and Moselhi (2012) proposed an approach for tracking earthmoving operations using Radio Frequency Identification (RFID). Their approach could automatically recognize four states of the trucks including loading, travelling, dumping and returning. As this approach uses fixed RFID readers for gate systems at the loading and dumping areas, it is more relevant to projects with fixed loading and dumping areas. Moreover, this approach cannot identify the waiting time of the trucks in the loading/dumping areas. In another study, Montaser and Moselhi (2014) developed an automated system integrating Global Positioning System (GPS) and Geographical Information System (GIS). This system tracks the location of the trucks using GPS units mounted on the trucks and identifies the spatial boundaries of loading and dumping areas using GIS. Similar to their previous approach, they recognized the same four states for the trucks and lacks the capability of capturing waiting times in the loading/dumping areas. To address this drawback and to improve accuracy of measuring excavated soil volume, Ibrahim and Moselhi (2014) developed an automated productivity assessment method for earthmoving operations. In this method, they used mobile sensors including GPS mounted on trucks to track their locations, accelerometers mounted on the bed of the trucks for tilt sensing of the truck bed, strain gauges mounted on truck leaf springs to measure soil weight, barometric pressure sensors attached to the bucket of loaders to measure elevation of the buckets, and RF module, which used Bluetooth for data transfer and proximity detection between equipment. They developed an algorithm to use the collected data from these sensors for the truck activity recognition including load queue, load, travel, dump queue, dump, return and service. The developed method measured productivity with only 2.2% error in a case study. Despite its high accuracy and simplicity of its computational requirements, implementation of this method needs installation of several sensors on the trucks and loaders, which are not often allowed by the equipment owners.

Ahn et al. (2012) utilised an accelerometer mounted inside the cabin of a medium-sized excavator collecting the data with the frequency of 100 Hz. They presented the relationship between operational efficiency and environmental performance using vibration signals. A further study by Ahn et al. (2015) explored capturing acceleration signals from four types of excavators using an accelerometer mounted inside the cabin and conducted the experiment under an instructed environment. The experiment involved the operation of an excavator that was strictly instructed to capture the required data in

order to analyze patterns of accelerometer data. They used different supervised classifiers including Naïve Bayes, Instance-based learning, K-nearest neighbor (KNN) and Decision tree (J48) and achieved over 93% accuracy for classification of excavators' operation.

One study explored approaches to detecting loading and unloading of a dumper truck with a remote tracking technique using 3-axis magnetic field sensing and 3-axis tilt sensing for a loader and a truck in an indoor laboratory (Akhavian and Behzadan, 2012). Akhavian and Behzadan (2015) also developed an automated method to detect equipment activities and their durations for simulation input modeling of a front-end loader using GPS sensor, 3-axis accelerometer, and 3-axis gyroscope with frequency of 100 Hz. This technique applied several supervised learning methods including logistic regression, K-NN, decision tree, neural network, support vector machine (SVM), and achieved an overall accuracy of more than 86%.

Some studies used Inertial Measurement Unit (IMU) data from the sensors embedded in smartphones including accelerometers and gyroscopes for equipment activity recognition. For instance, Kim et al. (2018) measured an excavator operation cycle time using IMU data with the frequency of 128 Hz. They applied Random Forest, Naïve Bayes, J48 and Sequential Minimal Optimization (SMO) for the cycle time prediction and achieved 91.83% accuracy. In another study Rashid and Louis (2019) used time-series data augmentation on 3-axis accelerometer, and 3-axis gyroscope data collected with the frequency of 80 Hz to generate synthetic training data for four types of excavator and front-end loader. This technique applied recurrent neural network (RNN) and achieved over 96% accuracy for fourfold augmentation.

Bae et al. (2019) developed a dynamic time warping algorithm for activity identification and automatic classification of excavator activities (i.e., digging, leveling, lifting, trenching, traveling, and idling) using joysticks signals. The correct-recognition rate of their model was between 91% and 97%.

Despite the contributions these studies bring to monitoring construction equipment activity, there is still a dearth of studies attempting to automate equipment productivity measurement. A recent attempt in this area by Chen et al. (2020) developed a vision-based method for measuring excavator productivity. However, this method revealed computationally complex and had some limitations such as dependency of the results on the light conditions, viewpoints of cameras, number of equipment in the scene and background movements. In addition, their achieved accuracy was 83% for productivity measurement, and 94% for idle time measurement. This study contributes to this research domain by developing and testing a low-cost and simple-to-implement method for automating equipment productivity measurement with high accuracy using smartphone sensors.

## METHODOLOGY

As discussed earlier, a range of metrics for measuring equipment productivity exist. In this paper we explore the metric utilization ratio (Equation 3) for measuring productivity. The main focus is on identifying whether or not an equipment is working during the time that it is available for use during the operation shift. Accordingly, two states for the equipment are defined: 1) active and 2) inactive. Active state relates to the time that the equipment is actively working. Inactive state relates to the time that the equipment is not working including the idle time and the time the equipment engine is off.

Smartphones are used for capturing IMU data (i.e., tri-axial accelerometer, gyroscope and linear acceleration data) and noise level data from inside the equipment operators' cabins. Figure 1 illustrates how these data are used to identify equipment states.

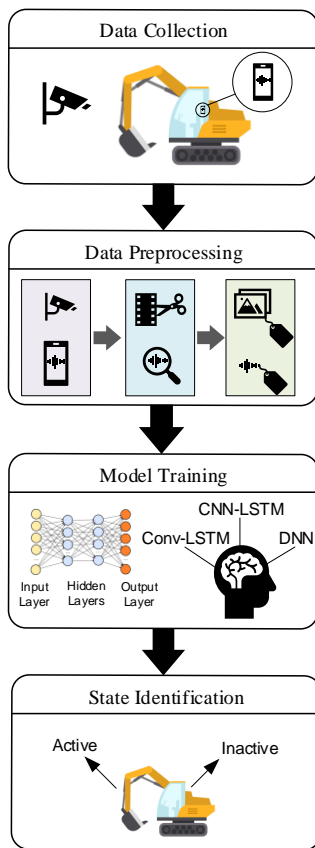

Figure 1: Modeling Process

As seen in Figure 1, the first step is to collect the required data. In this study, different types of smartphone sensor data including kinematics and noise level are captured. Smartphone sensor data are captured using a commercial application available on the phones. The application utilizes built-in smartphone sensors to capture IMU data and the noise level. In addition, a camera is used to capture videos from equipment activities on the construction site to identify when the equipment is active or inactive. Further, the videos are used for labeling the time-stamped sensor data and developing and validating

machine learning models.

The second step is data preprocessing, in which sliding windows to divide input signal data into windows of signals are identified. The size of each sliding window, which depends on the model specifications such as the data type and nature of the activities to be classified, impacts the model size and training speed: the smaller the window size, the smaller the model and the faster the training speed (Banos et al., 2014). That is, reducing the window size enables faster activity recognition and less computational burdens. Large windows are generally used for identifying complex activities (Banos et al., 2014). After selecting a suitable sliding window size, the data is labeled with the equipment states (i.e., either active or inactive) using the observations from the captured videos.

The preprocessed data are then fed to the deep learning model for classification. Deep learning algorithms are more suitable for complex activity recognition because they automate feature engineering and extraction (as one of the most important and challenging tasks in machine learning) and extract high-level representation in deep layers (Wang et al., 2019).

In this study three deep learning algorithms including Deep Neural Network (DNN), Convolutional Neural Network-Long Short-Term memory network (CNN-LSTM) and Convolutional Long Short-Term Memory (Conv-LSTM) were experimented. These algorithms are commonly used for activity recognition due to their deep structures for automated feature extractions from raw sensor data with random noises (Mahmud et al., 2020). These algorithms are applied to a various combination of data collected in a case study to compare their performance in predicting equipment states and measuring equipment productivity. The description of these algorithms is summarized below.

### Deep Neural Network (DNN)

DNN map inputs to outputs through a sequence of data transformations (layers). In the learning process of DNN, the values of the parameters (weights) of the layers are identified in such a way that the network correctly maps the input data to output data (i.e., minimizing the error) (Francois, 2017). DNN is computationally complex because many parameters exist for each layer and a change in one parameter will impact other parameter behaviors (Francois, 2017). More (deep) layers in DNN comparing to the traditional neural networks, make it a more suitable method for building a learning model from a large amount of data, where manually extracting features is too complex or time consuming for building a successful model.

In DNN, different types of layers such as dense, flatten, dropout and softmax layers can be used. Dense layers are a regular neuron layer, which are densely connected and receive input from the previous layer and send output to the next layer. The input and output are also connected by the weights. Flatten layers are used to make multidimensional output linear to pass it to the dense layer when

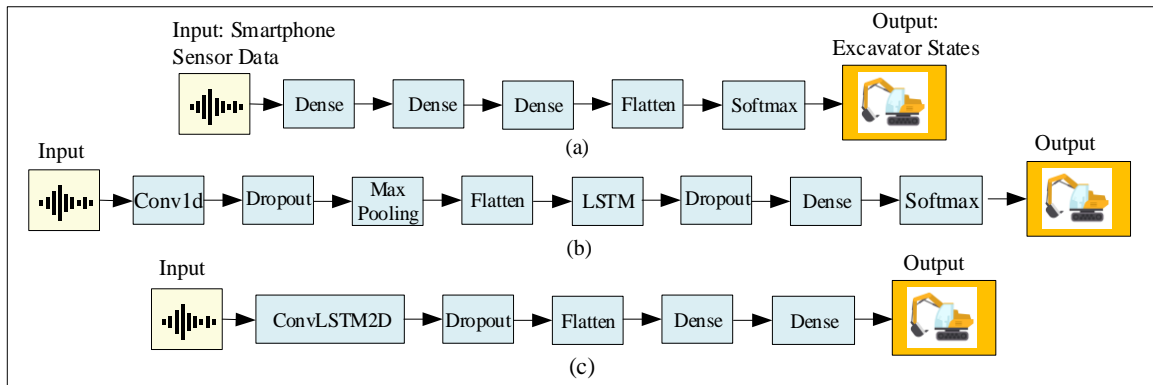

Figure 2: (a) DNN model architecture; (b) CNN-LSTM model architecture; (c) Conv-LSTM model architecture

required. Dropout is a regularization method, which randomly (at a probability) drops some neurons to prevent overfitting the model. Softmax can be used before the output layer to output a probability distribution over the different output classes, which identifies the probability that the sample belongs to a specific class (Francois, 2017). Figure 2 (a) depicts the architecture of the DNN model created in this study.

### Convolutional Neural Network-Long Short-Term memory network (CNN-LSTM)

CNN-LSTM integrates Convolutional Neural Network (CNN) with long short-term memory network (LSTM). CNNs are characterized by the ability of easy training, knowledge extraction and feature extraction on input data (Huang and Kuo, 2018). CNNs are mostly adopted for image processing. LSTM is a type of Recurrent neural networks (RNNs), which are used to learn from sequence data (i.e., sequences of observations over time) and can address some difficulties of RNN in training a stable model (Brownlee, 2016). LSTM develops internal representation of the input while reading input observations in sequence and focusing on model prediction errors in the input sequence in each time step, which is called back propagation over time (Brownlee, 2016).

In the CNN-LSTM architecture, 1) CNN performs feature extraction on input data through convolutional layers (e.g. Conv1D), which performs convolution operations to learn local patterns (while dense layers learn global patterns) (Francois, 2017), and pooling layers, which performs a down sampling operation to produce the most significant features (Swapna et al., 2018), and LSTM supports sequence prediction, 2) data are read sequentially in blocks and features are extracted from each block, and 3) the extracted features are fed into LSTM for interpretations and

predictions (Brownlee, 2018). CNN-LSTM is more efficient for recognition of activities with differing time spans such as visual time series prediction problems. As CNN is a specific type of DNN, DNN layers can also be used in CNN-LSTM models. Figure 2 (b) demonstrates the architecture of the CNN-LSTM model used in this study.

### Convolutional Long Short-Term Memory (Conv-LSTM)

Conv-LSTM is an extension of fully connected LSTM (FC-LSTM) by having convolutional structures for

LSTM gating in both the input-to-state and state-to-state transitions (Xingjian et al., 2015). In Conv-LSTM, an extra connection with the previous memory cells is established to account for the effect of the previous input in the current timestamp (Xingjian et al., 2015).

In the training process, the memory cell can consider the effect of the earliest stages (Rahman and Adjeroh, 2019). The main difference between CNN-LSTM and Conv-LSTM is that in CNN-LSTM, LSTM interprets the output from CNN model but in Conv-LSTM, the convolutions are used directly as part of reading input into LSTM (Brownlee, 2018). Conv-LSTM is suitable for predictions on 3-dimensional data (e.g., spatiotemporal data).

In this study, a special form of Conv-LSTM, so called Conv-LSTM 2D, which combines gating of LSTM with 2D convolutions, was used. The overall architecture of the model used in this study is presented in Figure 2 (c).

### TESTING AND DEMONSTRATION

The proposed method was implemented on a live demolition project where a Komatsu PC220LC Hydraulic Excavator was in use. A commercial mobile app was used to collect noise level and IMU data including accelerometer, gyroscope and linear acceleration data in three-dimensional axes. Two android smartphones were mounted inside the cabin of the excavator on the window to mitigate the risk of losing data due to the risk of the app crashing on one phone or other incidents. The frequency of data capturing was 8 Hz, which was the highest frequency at which the commercial app could run and capture data without crashing. A camera was used to capture the video and approximately 3 hours of the excavator operation was monitored. Figure 3 shows a snapshot of the captured video. As mentioned in the methodology section, this study intends to automatically measure the utilization ratio by recognizing two states of the equipment: active and inactive. During the monitored time, the excavator was mostly active working on demolishing a building. There were some occasions that the excavator operator stopped working for a short period of time, which was considered inactive time. Figures 4 to 7 show a sample of accelerometer, gyroscope, linear acceleration and noise level data when the excavator was active and inactive. The collected data were then preprocessed. The sliding window size was decided as five seconds as only two states that are not



complex in nature were considered for activity recognition. Since frequency of data was 8 Hz, 40 data sets were available for each window. These data sets were labeled using the captured video.



Figure 3: A snapshot of the captured video

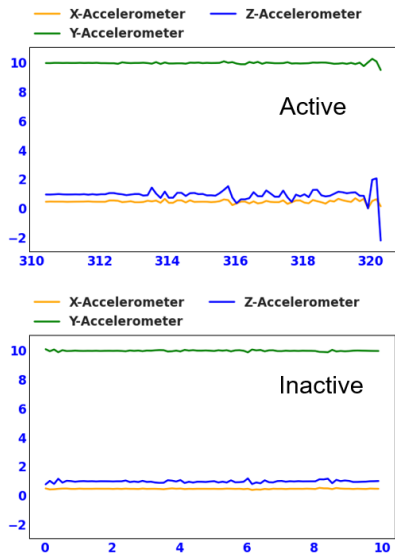

Figure 4: Sample of accelerometer data in x, y and z axis for active and inactive states

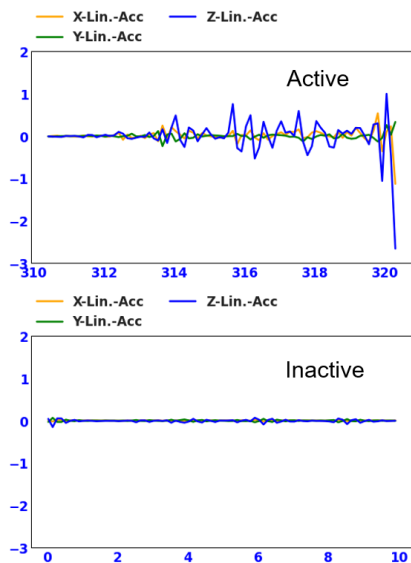

Figure 5: Sample of linear accelerometer data in x, y and z axis for active and inactive states

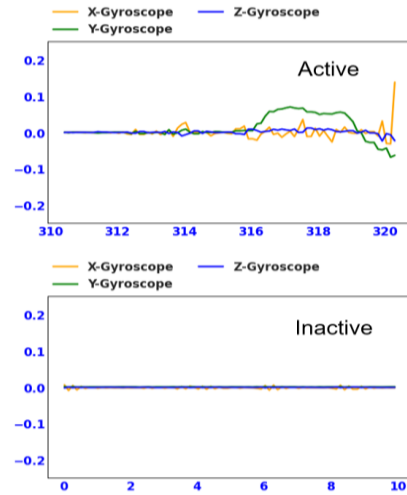

Figure 6: Sample of gyroscope data in x, y and z axis for active and inactive states

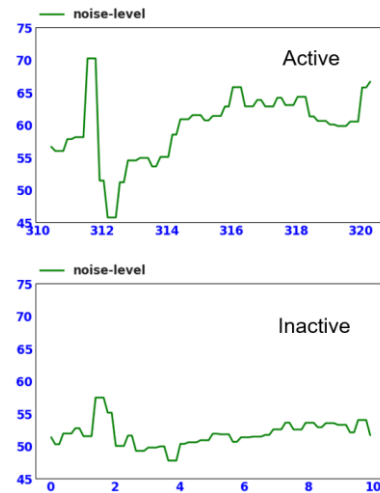

Figure 7: Sample of noise level data for active and inactive states

Three deep learning models using DNN, CNN-LSTM and Conv-LSTM algorithms were created using Keras deep learning package, a free open source library in Python, with Tensor-Flow as a backend engine. The models were created for three combinations of data:

- Accelerometer and gyroscope data
- Accelerometer, gyroscope and linear acceleration data
- Accelerometer, gyroscope data, linear acceleration and noise level data

The train/test ratio of 75/25 was used for splitting the dataset into train and test sets. Then, 80% of the train dataset was used as the actual train set and the remaining 20% was used as the validation set. After that, the model is iteratively trained and validated on these different sets. The accuracy was calculated as the number of correct predictions over the total number of predictions Equation 4.

$$Accuracy = \frac{TP + TN}{TP + TN + FP + FN} \quad (4)$$

where TP is True Positive, TN is True Negative, FP is False Positive, and FN is False Negative.

Table 1 shows the accuracy of experimented models for activity recognition.

Table 1: Accuracy for activity recognition

Input Data	Model Accuracy (%)		
	DNN	CNN-LSTM	Conv-LSTM
Accelerometer and gyroscope data	97.25%	96.93%	96.85%
Accelerometer, gyroscope and linear acceleration data	97.17%	96.77%	97.01%
Accelerometer, gyroscope data, linear acceleration and noise level data	97.01%	96.70%	97.01%

The actual utilization ratio was measured manually as 89.85% using the captured video. Using the result of the models, the utilization ratio can be automatically calculated as shown in Table 2, and accuracy of the models was calculated by comparing it with the actual utilization ratio as shown in Table 3.

Table 2: Predicted utilization ratio

Input Data	Predicted Utilization Ratio (%)		
	DNN	CNN-LSTM	Conv-LSTM
Accelerometer and gyroscope data	91.08%	91.36%	90.13%
Accelerometer, gyroscope and linear acceleration data	91.26%	92.34%	90.17%
Accelerometer, gyroscope data, linear acceleration and noise level data	90.04%	91.37%	91.45%

Table 3: Accuracy for measuring utilization ratio

Input Data	Model Accuracy (%)		
	DNN	CNN-LSTM	Conv-LSTM
Accelerometer and gyroscope data	98.63%	98.31%	99.68%
Accelerometer, gyroscope and linear acceleration data	98.43%	97.22%	98.53%
Accelerometer, gyroscope data, linear acceleration and noise level data	99.78%	99.42%	98.21%

## DISCUSSION

The developed model resulted in high accuracy for both activity recognition and productivity measurement. This accuracy can be attributed to capabilities of deep learning algorithms in feature engineering when large amount of data is available. Another contributor to this high accuracy comparing to similar studies (e.g., Ahn et al. (2015) with 93% accuracy and Kim et al. (2018) with 91.83% accuracy), is the lower level of details required for productivity measurement as this study considered two states (active and inactive) for the activity recognition. Although the accuracy levels are very high, they can be improved further with a larger amount of training data by increasing the frequency and/or duration of data collection. In this case study, DNN model using accelerometer and gyroscope data led to the highest accuracy (97.25%) for activity recognition. For productivity measurement, DNN using accelerometer, gyroscope data, linear acceleration and noise level data achieved the highest accuracy (99.78%). However, the variations of the achieved accuracies are insignificant among the models and the input combinations (less than 1% for activity recognition and less than 3% for productivity measurement), which could be because of the low level of details required for predictions. If a higher level of details is considered, more variation could be observed to be able to compare capabilities of different algorithms and the impact of input data. In this case study, the excavator was doing only one type of activity (i.e., building demolition).

To enhance application of the model, other types of activities such as excavation and loading can be studied to make the model more generic for excavator operations.

The main advantage of this method over other methods (e.g., vision-based methods and using other types of sensors) is that it is computationally less complicated, and inexpensive to implement. It is also relatively more accurate. For instance, the study by Chen et al. (2020) used a vision-based method and could achieve 93.8% accuracy for measuring idle time, which is similar to the inactive state in this study. Table 4 shows a detailed comparison between this study and other studies.

## LIMITATIONS AND FUTURE WORK

This study has some limitations that can be addressed in future. In the case study, the excavator activities were limited to demolition tasks. The proposed method can be experimented for other types of excavator activities such as excavation and loading to further substantiate its capabilities. As such, more complex activity recognition with more states maybe required to study more detailed equipment operation efficiency.

In this study, a commercial mobile application was used for capturing the data. The used application had limitations on the data capture frequency. The highest frequency rate to avoid crashing the application was 8 Hz while in similar studies higher rates were used. Despite

Table 4: (a) DNN model architecture; (b) CNN-LSTM model architecture; (c) Conv-LSTM model architecture

Reference	Used Data Type	Used Algorithms	Main Parameters	Accuracy	Number of states
Ahn et al. (2015)	Accelerometer data	Naïve Bayes, Instance-based learning, K-nearest neighbor (KNN) and Decision tree (J48)	Frequency: 100 Hz Sliding window size: 128-sample windows	93% for the activity classification	3
Kim et al. (2018)	Smartphone sensors (IMU)	Random Forest, Naïve Bayes, J48, and SMO	Frequency: 128 Hz Sliding window size: 1 second	91.83% accuracy for cycle time measurement	3
Cheng et al. (2020)	Surveillance video data	Faster R-CNN for excavator detection and deep Simple Online and Real-Time (SORT) for excavator tracking	Frequency: 25 frames per second (FPS), Sliding window size: 4 seconds.	93.8% for idle time measurement	2
This study	Smartphone sensor data	DNN, CNN-LSTM and Conv-LSTM were compared	Frequency: 8 Hz Sliding window size: 5 seconds.	99.78% for utilization ratio measurement	2

this limitation, the accuracy of the model in the case study was very high. In future studies, the impact of data capture frequency on the accuracy of the model can be explored. In addition, the capability of this method can be further explored by experimenting other types of equipment such as loaders and cranes.

## CONCLUSIONS

In this study, a deep learning method was proposed for automating equipment productivity measurement. This method uses kinematic and noise level data captured by smartphone sensors. Three deep learning algorithms including DNN, CNN-LSTM, and Conv-LSTM were experimented for activity recognition of an excavator and measuring productivity.

The results of the experiment showed high accuracy of the models (over 96.70% for activity recognition and over 97.22% for productivity measurement). The equipment-intensive construction project can benefit from the proposed method by measuring equipment productivity, producing benchmarks, and comparing the equipment performance with the benchmarks. Automating this process assists project managers to identify equipment inefficiencies in near real-time and to stimulate corrective actions to address the root causes of lagging performance; hence contributing to improve equipment productivity and reducing project time and costs.

## REFERENCES

- Ahn, C. R., Lee, S. & Peña-Mora, F. 2012. Monitoring system for operational efficiency and environmental performance of construction operations using vibration signal analysis. In *Proceedings of Construction Research Congress 2012: Construction Challenges in a Flat World*, West Lafayette, Indiana, United States. pp. 1879-1888.
- Ahn, C. R., Lee, S. & Peña-Mora, F. 2015. Application of low-cost accelerometers for measuring the operational efficiency of a construction equipment fleet. *Journal of Computing in Civil Engineering*, 29, 04014042. pp. 1-11.
- Akhavian, R. & Behzadan, A. H. 2015. Construction equipment activity recognition for simulation input modeling using mobile sensors and machine learning classifiers. *Advanced Engineering Informatics*, 29, pp. 867-877.
- Bae, J., Kim, K. & Hong, D. 2019. Automatic identification of excavator activities using joystick signals. *International Journal of Precision Engineering and Manufacturing*, 20, pp. 2101-2107.
- Banos, O., Galvez, J.-M., Damas, M., Pomares, H. & Rojas, I. 2014. Window size impact in human activity recognition. *Sensors*, 14, pp. 6474-6499.
- Brownlee, J. 2016. *Crash Course in Recurrent Neural Networks for Deep Learning* [Online]. Available: <https://machinelearningmastery.com/crash-course-recurrent-neural-networks-deep-learning/> [Accessed December 18, 2020 2020].
- Brownlee, J. 2018. *LSTMs for Human Activity Recognition Time Series Classification* [Online]. Available: <https://machinelearningmastery.com/how-to-develop-rnn-models-for-human-activity-recognition-time-series-classification/> [Accessed December 18, 2020 2020].
- Chen, C., Zhu, Z. & Hammad, A. 2020. Automated excavators activity recognition and productivity analysis from construction site surveillance videos. *Automation in Construction*, 110, 103045. pp. 1-13.
- Francois, C. 2017. *Deep learning with Python*. Manning Publications Company.
- Gerami Seresht, N. & Fayek, A. R. 2018. Dynamic modeling of multifactor construction productivity for



- equipment-intensive activities. *Journal of Construction Engineering and Management*, 144, 04018091.
- Gurmu, A. T. & Aibinu, A. A. 2017. Construction equipment management practices for improving labor productivity in multistory building construction projects. *Journal of Construction Engineering and Management*, 143, 04017081.
- Huang, C.-J. & Kuo, P.-H. 2018. A deep CNN-LSTM model for particulate matter (PM<sub>2.5</sub>) forecasting in smart cities. *Sensors*, 18, 2220.
- Ibbs Jr, C. W. & Terveer, K. R. 1984. Integrated construction preventive maintenance system. *Journal of construction engineering and management*, 110, pp. 43-59.
- Ibrahim, M. & Moselhi, O. 2014. Automated productivity assessment of earthmoving operations. *Journal of Information Technology in Construction (ITcon)*, 19, pp. 169-184.
- Kim, H., Ahn, C. R., Engelhaupt, D. & Lee, S. 2018. Application of dynamic time warping to the recognition of mixed equipment activities in cycle time measurement. *Automation in Construction*, 87, 225-234.
- Mahmud, T., Sayyed, A. S., Fattah, S. A. & Kung, S.-Y. 2020. A Novel Multi-Stage Training Approach for Human Activity Recognition from Multimodal Wearable Sensor Data Using Deep Neural Network. *IEEE Sensors Journal*, 21, pp. 1715-1726.
- Montaser, A. & Moselhi, O. Rfid+ for tracking earthmoving operations. In *Proceedings of Construction Research Congress 2012: Construction Challenges in a Flat World*, West Lafayette, Indiana, United States. 1011-1020.
- Montaser, A. & Moselhi, O. 2014. Truck+ for earthmoving operations. *Journal of Information Technology in Construction (ITcon)*, 19, pp. 412-433.
- Nepal, M. P. & Park, M. 2004. Downtime model development for construction equipment management. *Engineering, Construction and Architectural Management*. pp. 199-210.
- Ok, S. C. & Sinha, S. K. 2006. Construction equipment productivity estimation using artificial neural network model. *Construction Management and Economics*, 24, pp. 1029-1044.
- Rahman, S. A. & Adjeroh, D. A. 2019. Deep learning using convolutional LSTM estimates biological age from physical activity. *Scientific reports*, 9, pp. 1-15.
- Rashid, K. M. & Louis, J. 2019. Times-series data augmentation and deep learning for construction equipment activity recognition. *Advanced Engineering Informatics*, 42, 100944.
- Swapna, G., Kp, S. & Vinayakumar, R. 2018. Automated detection of diabetes using CNN and CNN-LSTM network and heart rate signals. *Procedia computer science*, 132, pp. 1253-1262.
- Vorster, M. C. & De La Garza, J. M. 1990. Consequential equipment costs associated with lack of availability and downtime. *Journal of Construction Engineering and Management*, 116, pp. 656-669.
- Wang, J., Chen, Y., Hao, S., Peng, X. & Hu, L. 2019. Deep learning for sensor-based activity recognition: A survey. *Pattern Recognition Letters*, 119, pp. 3-11.
- Xingjian, S., Chen, Z., Wang, H., Yeung, D.-Y., Wong, W.-K. & Woo, W.-C. 2015. Convolutional LSTM network: A machine learning approach for precipitation nowcasting. *Advances in neural information processing systems*, pp. 802-810.