

University of Groningen

Automated device for continuous stirring while sampling in liquid chromatography systems

Markovitch, Omer; Ottele, Jim; Veldman, Obe; Otto, Sijbren

Published in:
 Communications chemistry

DOI:
[10.1038/s42004-020-00427-5](https://doi.org/10.1038/s42004-020-00427-5)

IMPORTANT NOTE: You are advised to consult the publisher's version (publisher's PDF) if you wish to cite from it. Please check the document version below.

Document Version
 Publisher's PDF, also known as Version of record

Publication date:
 2020

[Link to publication in University of Groningen/UMCG research database](#)

Citation for published version (APA):

Markovitch, O., Ottele, J., Veldman, O., & Otto, S. (2020). Automated device for continuous stirring while sampling in liquid chromatography systems. *Communications chemistry*, 3(1), [180].
<https://doi.org/10.1038/s42004-020-00427-5>

Copyright

Other than for strictly personal use, it is not permitted to download or to forward/distribute the text or part of it without the consent of the author(s) and/or copyright holder(s), unless the work is under an open content license (like Creative Commons).

The publication may also be distributed here under the terms of Article 25fa of the Dutch Copyright Act, indicated by the "Taverne" license. More information can be found on the University of Groningen website: <https://www.rug.nl/library/open-access/self-archiving-pure/taverne-amendment>.

Take-down policy

If you believe that this document breaches copyright please contact us providing details, and we will remove access to the work immediately and investigate your claim.

Downloaded from the University of Groningen/UMCG research database (Pure): <http://www.rug.nl/research/portal>. For technical reasons the number of authors shown on this cover page is limited to 10 maximum.

Automated device for continuous stirring while sampling in liquid chromatography systems

Omer Markovitch ^{1,2}✉, Jim Ottel  ², Obe Veldman³ & Sijbren Otto ²

Ultra-performance liquid chromatography is a common analysis tool, and stirring is common in many laboratory setups. Here we show a device which enables continuous stirring of samples whilst inside an ultra-performance liquid chromatography system. Utilizing standard magnetic stirring bars that fit standard vials, the device allows for the automation of experimental setups that require stirring. The device is designed such that it can replace the standard sample holder and fits in its place, while being battery operated. The use of three-dimensional (3D) printing and commercially available parts enables low-effort and low-cost device production, as well as easy modifications. Testing the device was performed by video analysis and by following the kinetics of a dynamic combinatorial library that is known to be exquisitely sensitive to agitation, as a result of involving a fiber growth-breakage mechanism. Design files and schematics are provided.

¹Origins Center, Groningen, The Netherlands. ²Center for Systems Chemistry, Stratingh Institute, University of Groningen, Groningen, The Netherlands. ³Veldman Technische Ontwikkeling en Advisering, Groningen, The Netherlands. ✉email: omermar@gmail.com

High- and ultra- performance liquid chromatography (HPLC and UPLC, respectively) are common analytical tools for the detection and identification of components in complex mixtures¹. At the heart of these techniques is sampling and then separation of the sample by the use of a column with appropriate properties, leading to different compounds eluting at different times from the column.

Stirring a sample is fundamental in many experimental setups as it promotes mixture homogeneity. Furthermore, in systems where large assemblies are formed, mechanical agitation can lead to their breakage which may affect systems' behavior^{2,3}. Stirring can be achieved by placing a (Teflon coated) magnetic bar within a sample and placing the sample over a device with a rotating magnetic field.

Here, we have developed a UPLC stirring device that replaces a standard sample holder and enables battery-powered magnetic stirring in a similar manner to standard laboratory stirring devices. An experimental setup that requires continuous stirring can now be run inside the UPLC instrument, allowing for

multiple measurements at various times without the need for sample preparation or human intervention. We demonstrate the applicability of the device through the usage of a system that has previously been shown to be highly sensitive to stirring—exhibiting exponential growth that is enabled through a fiber elongation/breakage mechanism^{4,5}.

The development of this device employed open-source content and 3D printing^{6–8}, aligned with the increased do-it-yourself movement in science^{9–12}.

Results and discussion

Design of device. The design and development of the device employed open source and readily available parts in order to make it readily available for reproduction. The device's dimensions are such that it is interchangeable with the manufacturer-provided sample holder (Fig. 1). Each vial holders' dimension and position exactly match the standard. A motor is used for rotating an internal plate with magnets such that the magnetic stirring bars inside the sample vials will rotate and thus stirring is achieved. The control module is separated from the stirring module. The stirring speed range is 200–1200 rpm (in steps of 100) and is controlled by an onboard microcontroller and an organic light-emitting diode screen. Control over stirring speed of the plate with magnets is achieved via an internal feedback of the actual measured speed. A display reports the battery status and rotation rate.

Any measured speed difference of more than 10% compared to the user set speed which lasts more than 60 s, is considered an error and is indicated by an exclamation mark on the screen, while the device continues to operate. When turning the device on, if there were errors detected in the last run, a summary of their duration will appear on-screen (grouped into differences of 10–20, 20–30, 30–40, and more than 40%).

Validation. To validate the new device, a dynamic system of dithiols was studied (Fig. 2) This system is an excellent candidate to validate the device as: (i) the material is heterogeneous and settles to the bottom when not properly stirred, and (ii) the kinetics are highly sensitive to shear stress, as it has previously been shown that when it is subjected to mechanical agitation hexamer macrocycles assemble into fibers and exponentially grow

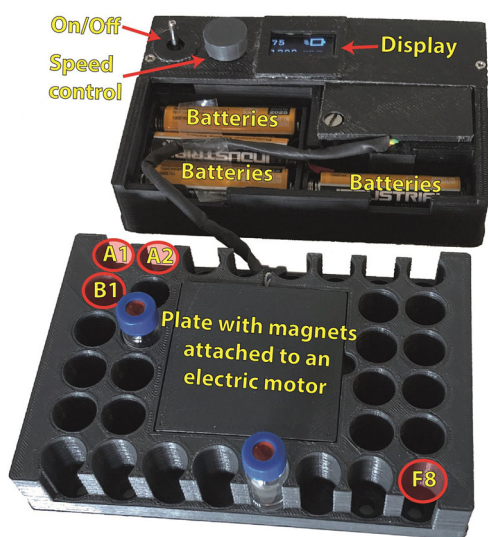

Fig. 1 Device overview. Sample holder positions are labeled A1 to F8.

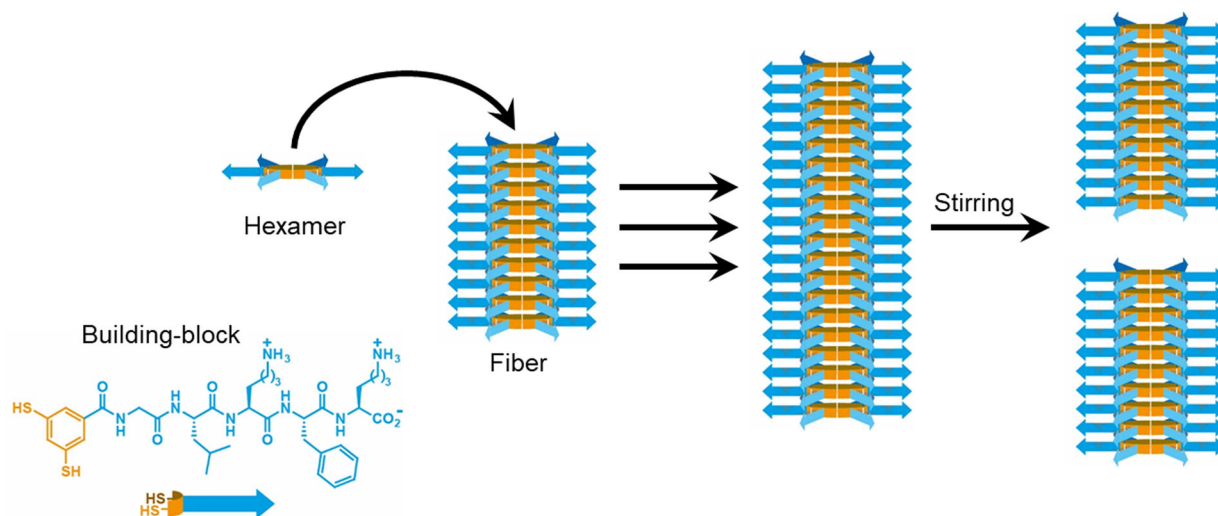

Fig. 2 Chemical system used to probe reproducibility of agitation. Oxidation of the dithiol building-block (either by air or by sodium perborate (NaBO_3)) leads to the formation of a mixture of disulfide macrocycles of different ring sizes (not shown). Of these, the hexamer self-assembles. The kinetics of autocatalytic formation of hexamer is highly sensitive to agitation, with growth rate depending linearly on the number of fiber ends.⁵ Fibers are fragile and the number of fiber ends is determined by the agitation regime.

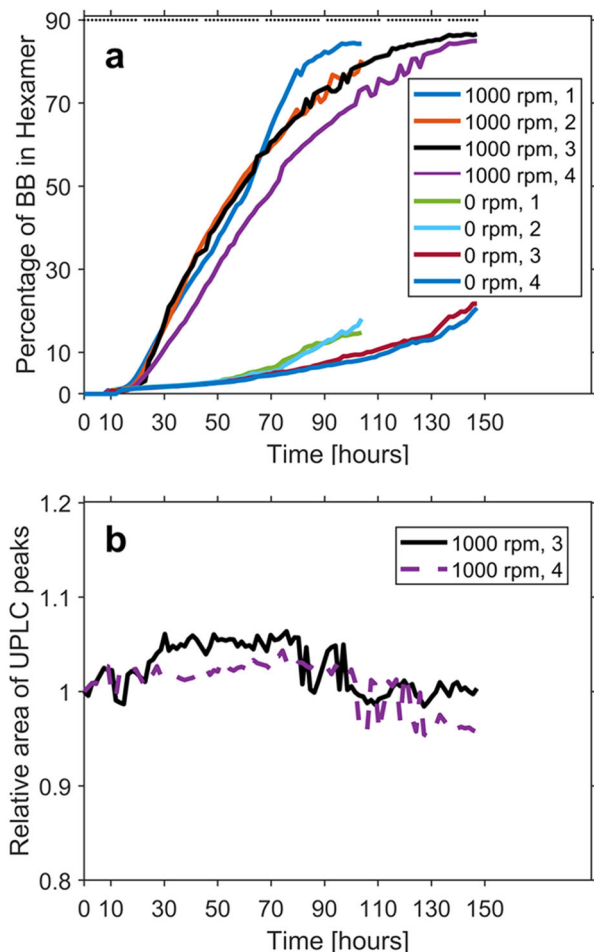

Fig. 3 Kinetics. **a** Hexamer emergence over time, given in percentage out of the initial building-block (BB) concentration, for stirred and unstirred samples. Two separate sets of experiments were run, each with two stirred samples and two unstirred samples. Black dots in panel a indicate the time point where a measurement was taken. For each condition, four repeats were performed. **b** Total area of all UPLC peaks detected by the UPLC software, relative to the initial total area (respectively 1.752×10^7 and 1.849×10^7 [arbitrary units]). Figure data are available in Supplementary Dataset 1.

and undergo self-replication⁴. Initial formation of fiber seeds (nucleation) is a stochastic process, and exponential growth occurs through a fiber elongation-breakage mechanism⁵ (Fig. 2). Due to the system's unique response to stirring, it is chosen to validate the device's performance.

Figure 3a shows the emergence kinetics of hexamers using the new stirring device, with and without stirring (4 repeats were performed for each case). Indeed, after approximately 100 h the total percentage of building-block mass in hexamers in the stirred samples reached an average value of 79 ± 5 vs only 13 ± 5 when unstirred, demonstrating the device's ability to consistently stir the samples through the course of the experiments. The small differences within each set of repeats is attributed to the stochastic nature of fiber nucleation. High throughput automatic sampling of the device allows for 60 to 90 consecutive measurements per each sample over the course of a week, and is indicated with small black dots on the very top of Fig. 3a. Animation of UPLC traces and a plot with chromatograms are respectively given in Supplementary Video 1 and Supplementary Note 3.

Given the high number of consecutive sampling it is important to test if the stirring quality is consistent throughout the

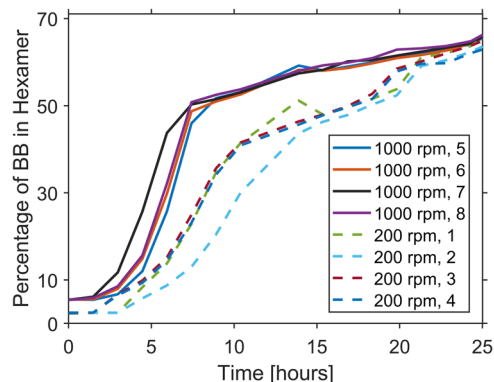

Fig. 4 Hexamer emergence over time, under pre-oxidation with NaBO_3 . Time to reach 50% of building-blocks in hexamer: 8.17 ± 0.86 h (1000 rpm), 17.2 ± 2.2 h (200 rpm). Four repeats were conducted for each condition. Two separate sets of experiments were run, stirred at 1000 and 200 rpm respectively. Figure data are available in Supplementary Dataset 1.

experiments. If a sample is not homogeneously stirred then fibers precipitate and therefore, when the UPLC needle is sampling, the fibers are under-represented, which results in loss of peak area. Figure 3b shows that, at each time point, the total area of all peaks is well conserved throughout, with a relative standard deviation of only 2.27 and 2.30%, respectively.

Figure 4 shows that, indeed stirring at different speeds leads to different rates of exponential growth, reflecting the established role of fibers and their breakage in this process⁵. This is in agreement with previous observations. It is noted that at the elevated temperature at which experiments were performed here (40°C), hexamer formation and replication speed are similar to the speed of building-block oxidation by air, which hampers observing differences under different stirring rates. Therefore, experiments shown in Fig. 4 were performed by first pre-oxidizing the building-block solution with NaBO_3 and then comparing 1000 with 200 rpm stirring rates (see Methods section).

In order to allow for a practical quantitative validation that does not depend on a specific chemical system, a video analysis was performed whereby the actual rotation speed of the Teflon coated magnet was measured in positions C2, D2, E2, F2, F3, A4, F4, A5, F5, C7 and D7 (Fig. 1), at a speed of 1000 and 200 rpm. These positions are chosen because they immediately surround the central motor, while positions in columns 1 and 8 exhibit diminished reproducibility of the stirring effect as they are further away from the device's center and experience a weaker magnetic field. This analysis finds an average speed of rotation which is 0.99 and 0.98 relative to the device's set rpm speed, thus confirming the device's functionality, i.e. only about 1% difference with the set stir speed (Supplementary Note 4 and Supplementary Videos 2). Due to symmetry, the video analysis also informs on positions A2, A3, A6, A7, B2, B7, E7, F7 and F8.

Starting from fresh batteries, the battery level is typically reduced to 35% after ~ 72 h of continuous stirring, at which point they were replaced.

Conclusions. A device for the continuous stirring of samples whilst inside a UPLC system is presented and validated. Such a device allows for the automation of experiments that require stirring and facilitates time-resolved UPLC measurements (e.g. for kinetics studies). The latter may be particularly advantageous when studying and modeling complex dynamic chemistries^{13,14}. It is our belief that such a device can be beneficial for other analytical laboratories around the globe.

In principle it is possible to amend the present design to fit to other chromatography machines and extend its capabilities. It is also possible to program the onboard microcontroller to allow for more complicated scenarios.

Methods

Design and fabrication of the stirring device. 3D printing was used for maximum versatility in design and manufacturing, as well as to allow user-specific modifications. User requests and stirring readouts are handled via ARDUINO Pro Mini 3.3 V 8 MHz microcontroller¹⁵. A standard motor is used for rotating a plate with magnets (magnet dimensions 25 × 8 × 1 mm³). Control over precise rotation rate of the plate is achieved via a magnetic sensor that provides feedback to the microcontroller. See Supplementary Note 5 and Supplementary Note 6 for components details and instructions on how to reproduce the device. Supplementary Dataset 3 contains the Arduino's firmware code.

3D components have been printed using Creatr Duel Extruder (nozzle diameter 0.35 mm) by Leapfrog and da Vinci 1.0 Pro (nozzle diameter 0.40 mm) by XYZ Printers, using PLA 1.75 mm filament under the following settings, unless stated otherwise: printing temperature was 205 °C, print bed temperature was 40 °C and at low printing speed (for reference, print time of the main body of the sample holder was about 13 h, and printing time of the main body of the control unit was about 10 h). Components' design is given in STL format (Supplementary Dataset 2).

The device's profile is approximately 4 mm higher than the standard default Waters acquity UPLC sample holder (catalogue number 700005209), and consequently UPLC needle height was adjusted. An overview of the device is given in Fig. 1.

Reaction setup. A 2.0 mM aqueous stock solution was prepared by dissolving 1.2 mg of a dithiol building-block (Fig. 2. Peptide amino acids sequence: Gly–Leu–Lys–Phe–Lys) in 607 µL borate buffer (50 mM in boron atoms, pH 8.12). Samples were prepared by adding 250 µL of the stock solution to a UPLC vial (dimensions 12 × 32 mm) and diluting it with 750 µL borate buffer. A Teflon coated stirring bar (dimensions 5 × 2 mm) was added to some of the samples and the vials were closed with a Teflon-lined screw cap.

Experiments and measurements. After preparation, samples were placed within the stirring device inside the UPLC instrument, with stirring turned on. The system was monitored by subjecting it to periodic UPLC analysis using a Waters Acquity UPLC-H Class system equipped with a photo diode array detector. All analyses were performed using a reversed-phase UPLC column (Aeris Peptide 1.7 µm XB-C18x 2.10 mm, Phenomenex). The column temperature was kept at 35 °C, and the sample chamber was kept at 40 °C. UV absorbance was monitored at 254 nm. Additional occasional column washes were performed. The eluents used in the UPLC separation consist of H₂O and acetonitrile, both are UPLC grade and contain 0.1 vol% trifluoroacetic acid. Gradient and peak integration algorithm are respectively given in Supplementary Note 1 and Supplementary Note 2.

For pre-oxidation experiments, the samples were prepared as described before, with the addition of 0.50 equivalents NaBO₃ so that 50% of the building-block amount is oxidized. Then, the resulting mixture was kept inside the UPLC sample holder and subjected to periodic UPLC analysis as described above. The samples were stirred using the designed device at 200 and 1000 rpm.

Device's positions used for samples are C2, C7, D2 and D7 (Fig. 1).

Data availability

The data supporting this publication and instructions for re-producing and constructing the stirring device are available at the SI and from the corresponding author upon request. Data is also available at <https://zenodo.org/record/4118046>.

Code availability

Supplementary Dataset 3: ARDUINO firmware program code.

Received: 17 June 2020; Accepted: 4 November 2020;

Published online: 03 December 2020

References

- Swartz, M. E. UPLC™: An Introduction and Review. *J. Liq. Chromatogr. Related Technol.* **28**, 1253–1263 (2007).
- Lee, C. C., Nayak, A., Sethuraman, A., Belfort, G. & McRae, G. J. A three-stage kinetic model of amyloid fibrillation. *Biophys. J.* **92**, 3448–3458 (2007).
- Malakoutikhah, M. et al. Uncovering the selection criteria for the emergence of multi-building-block replicators from dynamic combinatorial libraries. *J. Am. Chem. Soc.* **135**, 18406–18417 (2013).
- Carnall, J. M. et al. Mechanosensitive self-replication driven by self-organization. *Science* **327**, 1502–1506 (2010).
- Colomb-Delsuc, M., Mattia, E., Sadownik, J. W. & Otto, S. Exponential self-replication enabled through a fibre elongation/breakage mechanism. *Nat. Commun.* **6**, 7427 (2015).
- Gross, B., Lockwood, S. Y. & Spence, D. M. Recent Advances in Analytical Chemistry by 3D Printing. *Anal. Chem.* **89**, 57–70 (2017).
- Gross, B. C., Erkal, J. L., Lockwood, S. Y., Chen, C. & Spence, D. M. Evaluation of 3D printing and its potential impact on biotechnology and the chemical sciences. *Anal. Chem.* **86**, 3240–3253 (2014).
- Ventola, C. L. Medical Applications for 3D Printing: Current and Projected Uses. *P. T.* **39**, 704–711 (2014). PMID: 25336867; PMCID: PMC4189697.
- Fisher, D. K. & Gould, P. J. Open-Source Hardware Is a Low-Cost Alternative for Scientific Instrumentation and Research. *Mod. Inst.* **01**, 8–20 (2012).
- Meloni, G. N. & Bertotti, M. 3D printing scanning electron microscopy sample holders: A quick and cost effective alternative for custom holder fabrication. *PLoS ONE* **12**, e0182000 (2017).
- Pohanka, M. Three-Dimensional Printing in Analytical Chemistry: Principles and Applications. *Anal. Lett.* **49**, 2865–2882 (2016).
- Kitson, P. J., Marshall, R. J., Long, D., Forgan, R. S. & Cronin, L. 3D printed high-throughput hydrothermal reactionware for discovery, optimization, and scale-up. *Angew. Chem. Int. Ed.* **53**, 12723–12728 (2014).
- Ashkenasy, G., Hermans, T. M., Otto, S. & Taylor, A. F. Systems chemistry. *Chem. Soc. Rev.* **46**, 2543–2554 (2017).
- Markovitch, O. & Krasnogor, N. Predicting species emergence in simulated complex pre-biotic networks. *PLoS ONE* **13**, e0192871 (2018).
- Badamasi Y. A. The working principle of an Arduino. In *2014 11th International Conference on Electronics, Computer and Computation (ICECCO)* pp 1–4 (IEEE, 2014).

Acknowledgements

O.M. is funded through the NWA StartImpuls. This work has been funded by the ERC (AdG 741774), the NWO (Vici grant 724.012.002) and the Dutch Ministry of Education, Culture and Science (Gravitation program 024.001.035). We thank Andreas Hussain for discussions.

Author contributions

O.M. designed the device, with input from J.O. and O.V. J.O. designed and performed experiments, with input from O.M. O.V. constructed the device. O.M. wrote the manuscript draft. O.M., J.O., O.V. and S.O. wrote, read and approved the manuscript.

Competing interests

The authors declare no competing interests.

Additional information

Supplementary information is available for this paper at <https://doi.org/10.1038/s42004-020-00427-5>.

Correspondence and requests for materials should be addressed to O.M.

Reprints and permission information is available at <http://www.nature.com/reprints>

Publisher's note Springer Nature remains neutral with regard to jurisdictional claims in published maps and institutional affiliations.



Open Access This article is licensed under a Creative Commons Attribution 4.0 International License, which permits use, sharing,

adaptation, distribution and reproduction in any medium or format, as long as you give appropriate credit to the original author(s) and the source, provide a link to the Creative Commons license, and indicate if changes were made. The images or other third party material in this article are included in the article's Creative Commons license, unless indicated otherwise in a credit line to the material. If material is not included in the article's Creative Commons license and your intended use is not permitted by statutory regulation or exceeds the permitted use, you will need to obtain permission directly from the copyright holder. To view a copy of this license, visit <http://creativecommons.org/licenses/by/4.0/>.

© The Author(s) 2020

Supplementary information: Automated device for continuous stirring while sampling in liquid chromatography systems

Omer Markovitch^{1,2,*}, Jim Ottel ², Obe Veldman³ and Sijbren Otto²

1 Origins Center, Groningen, The Netherlands

2 Center for Systems Chemistry, Stratingh Institute, University of Groningen, Groningen, The Netherlands

3 Veldman Technische Ontwikkeling en Advisering, Groningen, The Netherlands

* omermar@gmail.com

Supplementary Note 1. UPLC eluents and gradient

Both H₂O and acetonitrile (CH₃CN) used were UPLC grade and contain 0.1 v% trifluoroacetic acid (CF₃CO₂H). Gradient is given in Table S1.

Table S1: UPLC gradient.

| Time [min.] | % H ₂ O | % Acetonitrile |
|-------------|--------------------|----------------|
| 0.0 | 90 | 10 |
| 1.0 | 90 | 10 |
| 1.3 | 75 | 25 |
| 3.0 | 72 | 28 |
| 11.0 | 60 | 40 |
| 11.5 | 5 | 95 |
| 12.0 | 5 | 95 |
| 12.5 | 90 | 10 |
| 17.0 | 90 | 10 |

Supplementary Note 2. Peak integration algorithm

Waters Empower software was used for the integration of peaks. The ApexTrack algorithm was used with the following parameters: Start=5.9 (min.), End=12.5 (min.), Peak Width=4.65 (sec.), Detection Threshold=24, Lutoff=0.0%, Touchdown=0.5%, Minimum Area=9000 and Minimum Height=8000.

Supplementary Note 3. Chromatograms

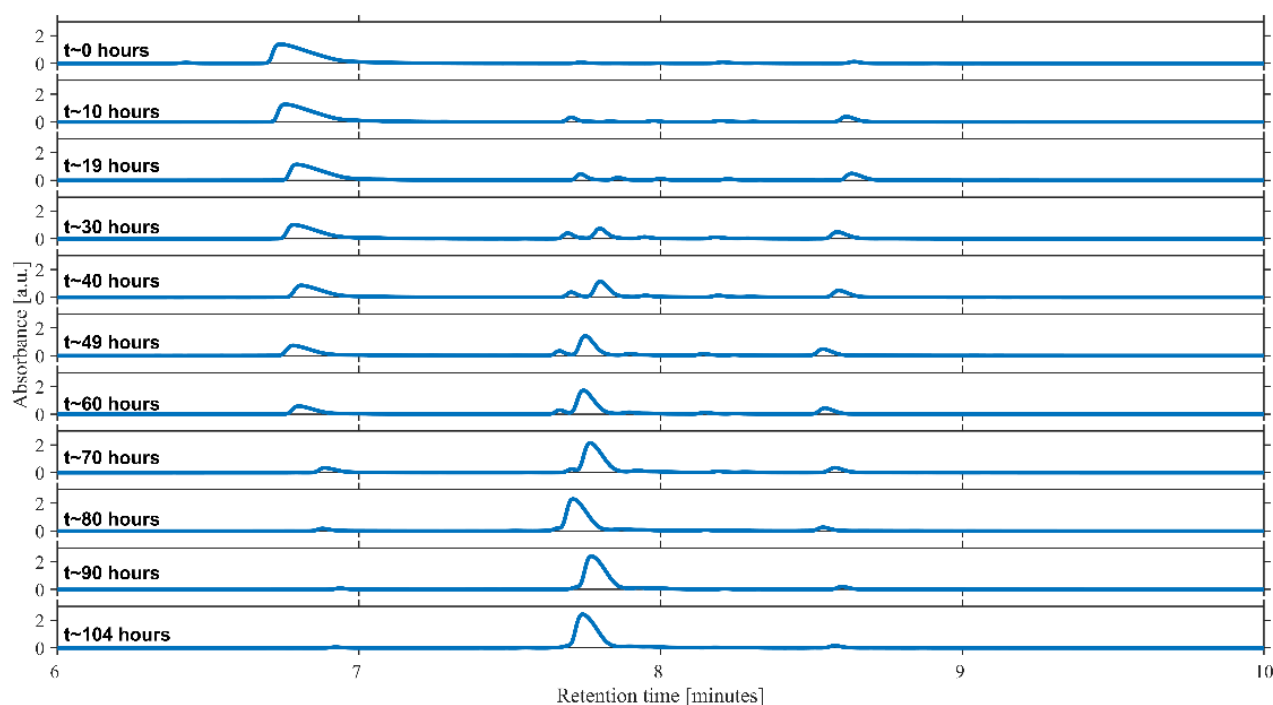

Figure S1: UPLC chromatograms of a sample measured under continuous stirring at 1000 rpm (“1000 rpm, 1” in Fig. 3a in the main text).

Supplementary Note 4. Quantitative validation using video analysis

In order to further validate the stirring device and provide a quantitative assessment of its stirring, a video analysis has been performed on the individual positions. In this analysis, a stirred sample is recorded using a high speed camera for a short duration and then the video is analysed by counting the number of revolutions the Teflon-coated magnet has undergone when the device is set at 200 or 1000 rpm. Relative to the user set speed, the average speed of rotation is 0.99 and 0.98 respectively for 200 and 1000 rpm (Table S2), thus confirming the device’s functionality. Because of symmetry the analysis focused on the positions in one quadrant surrounding the central motor and in addition all the positions used in the present study. Results are summarized in Table S2. Videos are available as an attachment (note: attached videos are slowed down $\times 4$).

Table S2: Measured rpm of positions (see Fig. 1 in the main text) analysed by video. Analysis counted 30-40 revolutions per position, and data is given in revolutions per minute (rpm). Videos were taken using a Sony actioncam AS20 camera at 120 frames per second (fps), and manually analysed by visual inspection using Kinovea software.

| Position | Device 200 rpm | Device 1000 rpm |
|----------|----------------|-----------------|
| A4 | 201 | 986 |
| A5 | 198 | 962 |
| C2 | 196 | 1011 |
| D2 | 197 | 986 |
| E2 | 200 | 974 |
| F2 | 197 | 986 |
| F4 | 202 | 968 |
| F5 | 197 | 968 |
| C7 | 198 | 986 |
| D7 | 195 | 968 |

Supplementary Note 5. Reproducing the stirring device

The components are (in brackets is the component 3D model file name):

- a) Disc onto which magnets will be attached to create the magnetic field (disc.stl; https://www.supermagnete.nl/eng/block-magnets-neodymium/block-magnet-25mm-8mm-1mm_Q-25-08-01-N). This disc may be 3D printed with ABS material (235 °C printing temperature and 90 °C print bed temperature).
- b) A CD/DVD Motor (MABUCHI motor RF300FA).
- c) Modified sample holder (holder.stl). This design allows for improved visual inspection of some of the sample position. The device's profile is approximately 4 mm higher than the standard default sample holder, and consequently the UPLC needle height should be adjusted.
- d) Cover for disc (coverdisc.stl).
- e) Sensor to detect the disc speed and sensor housing (infineon TLE4905L; sensor.stl).
- f) Arduino firmware program – attached.
- g) Arduino microcontroller (Arduino Pro Mini 3.3V 8MHz).
- h) Printed circuit board – see below.

- i) Display (SSD1306 OLED display 1 inch I2C) and part for mounting the display onto the control device (display.stl).
- j) Power switch.
- k) Knob to adjust stirring speed (knob.stl).
- l) Housing for AA batteries.
- m) Control device in the shape of a standard sample holder (control.stl).
- n) Cover for control device (covercontrol.stl).
- o) Cover for motor (covermotor.stl).

Figure S2 provides snapshots of the 3D components. All of the 3D design files of the components are also available from the corresponding author and at: <https://zenodo.org/record/4118046>.

Device's assembly steps:

1. Make holes for magnets in disc (component a), and attach magnets. It is possible to add more magnets (for example, 2 in each side) for a stronger magnetic field. Make sure the disc is balanced.
2. Connect disc to motor (component b).
3. Place disc-motor within the modified sample holder (component c). Make sure motor is firmly attached to the modified sample holder. Rubber band may be needed.
4. Attach disc cover to the bottom of the modified sample holder (component d). Screws are needed.
5. Install speed sensor (component e) near the motor.
6. Install program onto Arduino controller (components f & g).
7. Connect circuit board (component h) to display, power switch, speed knob, speed sensor, battery housing and Arduino (components i, j, k, l & h). Cables and soldering are needed.
 - 7.1. Place the connected circuit board inside the control device (component m).
 - 7.2. Attach cover for control device (component n).
8. Attach cover for motor (component o).

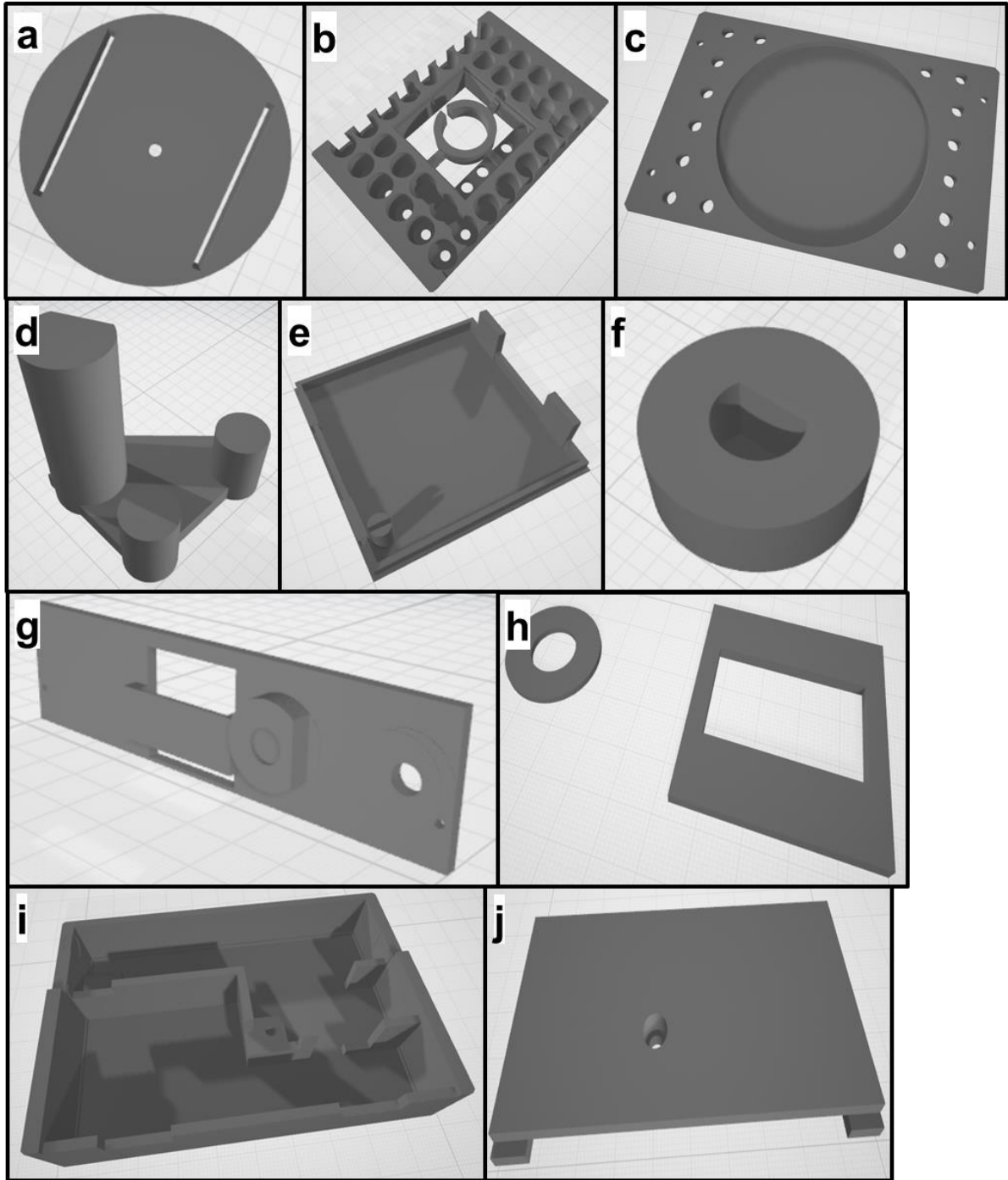

Figure S2: Snapshots of the individual 3D printed components listed in Supplementary Note 5. (a) disc.stl. (b) holder.stl. (c) coverdisc.stl. (d) sensor.stl. (e) covermotor.stl. (f) knob.stl. (g) display.stl. (h) bezel.stl. (i) control.stl. (j) covercontrol.stl.

Supplementary Note 6. Circuit board design and electronics

Circuit design is given in Figure S3 and the components list is given in Table S3.

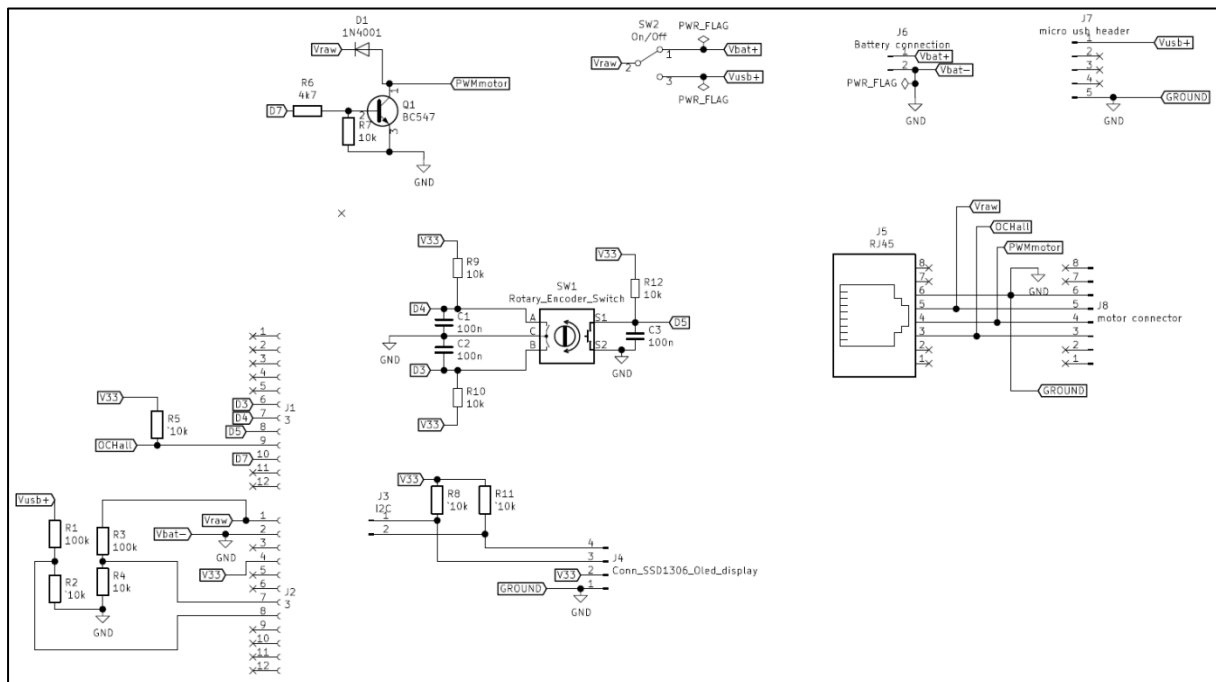

Figure S3: Printed circuit board (PCB) design.

Table S3: List of electronic and other components that are part of the PCB (Figure S3).

| Reference | Value | Footprint | Part | Description |
|-----------|-----------------------|--|------------------------------|--|
| Q1 | BC547 | TO_SOT_Packages_THT:TO-92_Molded_Narrow_Reverse | BC547 | 0.1A Ic, 45V Vce, Small Signal NPN Transistor, TO-92 |
| R6 | 4k7 | Resistors_SMD:R_1206_HandSoldering | R | Resistor |
| R7 | 10k | Resistors_SMD:R_1206_HandSoldering | R | Resistor |
| SW1 | Rotary_Encoder_Switch | footprintlib:Rotary_Encoder_Switch_Vertical | Rotary_Encoder_Switch-Device | |
| J1 | 3 | Pin_Headers:Pin_Header_Straight_1x12_Pitch2.54mm | Conn_01x12_Female | Generic connector, single row, 01x12, script generated (kicad-library-utils/schlib/autogen/connector/) |
| J2 | 3 | Pin_Headers:Pin_Header_Straight_1x12_Pitch2.54mm | Conn_01x12_Female | Generic connector, single row, 01x12, script generated (kicad-library-utils/schlib/autogen/connector/) |
| R3 | 100k | Resistors_SMD:R_1206_HandSoldering | R | Resistor |
| R4 | 10k | Resistors_SMD:R_1206_HandSoldering | R | Resistor |
| J5 | RJ45 | footprintlib:RJ45_8_REV | RJ45 | RJ connector, 8P8C (8 positions 8 connected) |

| | | | | |
|-----|---------------------------|--|-----------------|--|
| D1 | 1N4001 | Diodes_THT:D_DO-41_SOD81_P10.16mm_Horizontal | 1N4001 | 50V 1A General Purpose Rectifier Diode, DO-41 |
| C2 | 100n | Capacitors_SMD:C_0805_HandSoldering | C_Small | Unpolarized capacitor, small symbol |
| C1 | 100n | Capacitors_SMD:C_0805_HandSoldering | C_Small | Unpolarized capacitor, small symbol |
| C3 | 100n | Capacitors_SMD:C_0805_HandSoldering | C_Small | Unpolarized capacitor, small symbol |
| R9 | 10k | Resistors_SMD:R_1206_HandSoldering | R_Small | Resistor, small symbol |
| R10 | 10k | Resistors_SMD:R_1206_HandSoldering | R_Small | Resistor, small symbol |
| R12 | 10k | Resistors_SMD:R_1206_HandSoldering | R_Small | Resistor, small symbol |
| SW2 | On/Off | footprintlib:spdt switch | SW_SPDT | Switch, single pole double throw |
| J6 | Battery connection | Pin_Headers:Pin_Header_Straight_1x02_Pitch2.54mm | Conn_01x02_Male | Generic connector, single row, 01x02, script generated (kicad-library-utils/schlib/autogen/connector/) |
| J8 | motor connector | Pin_Headers:Pin_Header_Straight_1x08_Pitch2.54mm | Conn_01x08_Male | Generic connector, single row, 01x08, script generated (kicad-library-utils/schlib/autogen/connector/) |
| R1 | 100k | Resistors_SMD:R_1206_HandSoldering | R | Resistor |
| R2 | 10k | Resistors_SMD:R_1206_HandSoldering | R | Resistor |
| J7 | micro usb header | Pin_Headers:Pin_Header_Straight_1x05_Pitch2.54mm | Conn_01x05_Male | Generic connector, single row, 01x05, script generated (kicad-library-utils/schlib/autogen/connector/) |
| R5 | 10k | Resistors_SMD:R_1206_HandSoldering | R | Resistor |
| J3 | I2C | Pin_Headers:Pin_Header_Straight_1x02_Pitch2.54mm | Conn_01x02_Male | Generic connector, single row, 01x02, script generated (kicad-library-utils/schlib/autogen/connector/) |
| R8 | 10k | Resistors_SMD:R_1206_HandSoldering | R | Resistor |
| R11 | 10k | Resistors_SMD:R_1206_HandSoldering | R | Resistor |
| J4 | Conn_SSD1306_Oled_display | Pin_Headers:Pin_Header_Straight_1x04_Pitch2.54mm | Conn_01x04_Male | Generic connector, single row, 01x04, script generated (kicad-library-utils/schlib/autogen/connector/) |