

University of Groningen

The in vitro spermatozoal penetration test in fertility investigations

Kremer, Jan

IMPORTANT NOTE: You are advised to consult the publisher's version (publisher's PDF) if you wish to cite from it. Please check the document version below.

Document Version

Publisher's PDF, also known as Version of record

Publication date:

1968

[Link to publication in University of Groningen/UMCG research database](#)

Citation for published version (APA):

Kremer, J. (1968). *The in vitro spermatozoal penetration test in fertility investigations*. [Thesis fully internal (DIV), University of Groningen]. [S.n.].

Copyright

Other than for strictly personal use, it is not permitted to download or to forward/distribute the text or part of it without the consent of the author(s) and/or copyright holder(s), unless the work is under an open content license (like Creative Commons).

The publication may also be distributed here under the terms of Article 25fa of the Dutch Copyright Act, indicated by the "Taverne" license. More information can be found on the University of Groningen website: <https://www.rug.nl/library/open-access/self-archiving-pure/taverne-amendment>.

Take-down policy

If you believe that this document breaches copyright please contact us providing details, and we will remove access to the work immediately and investigate your claim.

Downloaded from the University of Groningen/UMCG research database (Pure): <http://www.rug.nl/research/portal>. For technical reasons the number of authors shown on this cover page is limited to 10 maximum.

the in vitro
spermatozoal penetration test in
fertility investigations

J. Kremer

*the in vitro spermatozoal penetration test in
fertility investigations*

RIJKSUNIVERSITEIT TE GRONINGEN

*the in vitro spermatozoal penetration test
in fertility investigations*

PROEFSCHRIFT

ter verkrijging van het doctoraat in de geneeskunde
aan de Rijksuniversiteit te Groningen
op gezag van de Rector Magnificus Dr. J. Th. Snijders,
hoogleraar in de faculteit der sociale wetenschappen,
in het openbaar te verdedigen op woensdag 15 mei 1968
des namiddags te 4 uur
door

JAN KREMER

geboren te Wildervank

1968

Drukkerij Van Denderen n.v.
Groningen

PROMOTOR: PROF. DR. L. A. JOOSSE
COREFERENT: DR. G. HELLINGA

This thesis was prepared in the Department of Obstetrics and Gynecology, University of Groningen, The Netherlands. Head of the Department: Prof. Dr. L. A. Joosse.

table of contents

Acknowledgements	1
Terminology	3
Chapter 1	
<i>In vitro</i> spermatozoal penetration tests as described by other authors	5
A. Coverslip methods	5
B. Capillary methods	15
Chapter 2	
The SPM test	24
A. Construction of the SPM	24
B. Obtaining and evaluating the materials necessary for the investigations	25
a. Acquiring and transporting the ejaculates	25
b. Evaluation of the ejaculates	28
c. Collection of the cervical mucus	31
d. Evaluation of the cervical mucus	34
e. Obtaining an alternative medium to cervical mucus	40
C. Performance of the SPM test	42
Chapter 3	
Results of the investigations with the SPM test	50
A. Preliminary investigations	50
I Investigation into the possibility of passive transfer of nonmotile particles from the semen reservoir into the fluid-filled glass capillary of the SPM	50
II Investigation into the effect of temperature on the result of the SPM test	53
III Investigation comparing the results of the SPM test when different fluids were used as penetration medium	53
IV Investigation into the effect of storage of human blood serum under deep-frozen conditions on the results of the SPM test, when this deep-frozen blood serum was used after thawing as penetration medium	54
V Investigation into the reproducibility of the SPM test	55

B.	<i>Results of the investigations with the S P M test as a routine part of the sterility examination</i>	57
I	<i>Procedure for performance of the investigations</i>	57
II	<i>Results of the investigations</i>	63
1.	<i>The results with normal ovulation cervical mucus as penetration medium and semen of different quality</i>	63
2.	<i>The results with cervical mucus having one or more physico-chemical properties which made it unfavourable for penetration, migration and survival of spermatozoa</i>	69
3.	<i>The results with heterologous cervical mucus the physico-chemical properties of which agreed with the normal values for cervical mucus from the ovulation period</i>	71
4.	<i>The results using normal cervical mucus from the ovulation period in order to determine the rate of progression of spermatozoa therein at room temperature</i>	71
5.	<i>The results with blood serum as penetration medium</i>	72
C.	<i>Investigations with the S P M test to determine how long after coitus spermatozoa from the intravaginal seminal pool can penetrate into the cervical mucus</i>	73
D.	<i>Results of the investigations with the S P M test as part of a contraception research project</i>	74
E.	<i>The S P M test as an aid to the investigation of the incompatibility between the blood serum of the wife and the spermatozoa of the husband</i>	77
F.	<i>The S P M test for detection of spermatozoal immobilizing materials in the blood serum of the man</i>	80
G.	<i>Relationship between the morphology of the spermatozoa in the semen and of the spermatozoa which have penetrated from this semen into the cervical mucus in the capillary of the S P M</i>	83
Chapter 4		
	<i>Comparative investigation of the results of the Miller-Kurzrok test and of the S P M test</i>	85
Chapter 5		
	<i>The relationship between the S P M test and the Sims-Huhner test</i>	88
Part I	<i>Review and discussion of the literature concerning the Sims-Huhner test</i>	88
A.	<i>The "filter" theory</i>	89
B.	<i>The "depot" theory</i>	91
Part II	<i>Materials and methods</i>	96
	Summary and Conclusions	103
	Samenvatting en Conclusies	113
	Résumé et Conclusions	125
	Zusammenfassung und Schlussfolgerungen	137
	References	149
	Tables	

acknowledgements

I am grateful to my teacher and promotor, Prof. Dr. L. A. JOOSSE and to Dr. G. HELLINGA for their valuable support, fruitful suggestions and amiable criticism in the performance of this thesis.

Prof. Dr. J. W. v. d. BERG (Department of Medical Physics), Prof. Dr. G. CHALLA, Drs. L. DIJKEMA (Department of Technical Chemistry) and Prof. Dr. F. J. KEUNING (Department of Histology) advised in problems concerning the physical, chemical and histological properties of the investigated materials.

Prof. Dr. T. HUIZINGA and Miss E. K. CHRISTENSEN (Pharmaceutical Department) were helpful in furnishing some of the important materials.

The electron microscopic studies were done in cooperation with Dr. E. F. J. VAN BRUGGEN (Laboratory of Structural Chemistry).

Dr. PH. RÜMKE (Antoni van Leeuwenhoekhuis, Amsterdam) performed the sperm-agglutination tests.

The photomicrographs were made by Drs. J. J. WACHTERS (Department of Medical Photography) and C. VAN DUIJN, Chem. E., M. I. Biol., A. Inst. P. (Research Institute for Animal Husbandry, Zeist).

The research materials from bovine origin were provided by the Centre for Artificial Insemination, Marum, with the help of Drs. J. HOFMAN.

Dr. R. K. KOOPMANS (District Laboratory for Public Health) was helpful in the performance of the bacteriological investigations.

The statistical treatment of the material was carried out by Drs. H. BRONTS (Department of Social Medicine).

The laboratory work was done by Mrs. U. W. KERSTEN-KLEEF, Miss A. GROENHUIS and Mr. M. KRANS. Line drawings were provided by Mr. H. B. HARSEVOORT. Literature was collected by Miss A. M. HEITING.

The English text was corrected by Miss JOAN MACY; the final correction of the text was undertaken by Professor D. R. M. WILKINSON of the English Department of Groningen University.

The institution "De Drie Lichten" furnished a financial grant.

I am greatly indebted to all mentioned above and also to my colleagues, students, nurses and administrative personnel, who, freely or as a routine part of their work, contributed to the investigations.

Finally I should like to acknowledge the married couples in whose interest the investigations were done. If the results will benefit them and others, the work has not been done in vain.

Groningen, May 1968.

terminology

spermatozoon (plural: spermatozoa) = a mature male germ cell

In this thesis *sperm*, in the sense of spermatozoon, is used only in some compound words. There are authors who use the word sperm to indicate the semen.

quantitative spermatozoal motility = percentage of active spermatozoa per visual field

qualitative spermatozoal motility = speed of forward progression of spermatozoa (graded in points)

azoospermia = lack of spermatozoa in the semen

oligozoospermia = deficiency in the number of spermatozoa in the semen

asthenozoospermia = reduced spermatozoal motility

teratozoospermia = too many spermatozoa with abnormal headforms in the semen

phalanx (gr.: φαλαγξ) = spearhead-like projection of spermatozoa, penetrating from semen into cervical mucus

The plural *phalanxes* is preferred to *phalanges* because the latter is generally used for the plural of phalanx in the sense of fingerbone.

<i>ovulatory phase</i>	= a period of three days from the 16th up to and including the 14th day before the first day of the next expected menstruation. With a cycle of less than 28 days, the midcycle day was regarded as the day of ovulation; this day and the two preceding days constituted the ovulatory phase.
<i>immobilizins</i>	= immobilizing antibodies
<i>agglutinins</i>	= agglutinating antibodies
<i>S P M</i>	= sperm penetration meter
<i>S P M test</i>	= the <i>in vitro</i> spermatozoal penetration test using the S P M
<i>L P F</i>	= low power field
<i>H P F</i>	= high power field
<i>R T</i>	= room temperature
<i>tr.</i>	= trace (a very slight amount)
<i>sp.</i>	= sporadic (very infrequent occurrence)
<i>spor.</i>	
<i>neg.</i>	= negative (nothing, zero)
-	= clearly evident that determination is not possible
- between two numbers	= second number not included
.	= no data available or determination technically not possible

The contemplation of the marvels of structure, biochemical constitution and potentialities of the spermatozoon is further proof that we are truly "fearfully and wonderfully made".

CARL G. HARTMAN (1962)

chapter 1

in vitro spermatozoal penetration tests as described by other authors

A. Coverslip methods

In 1932 MILLER and KURZROK described a simple *in vitro* spermatozoal penetration test which appeared to be suitable as a routine part of sterility investigations. The performance of this test, which has since become classical, was as follows:

After "adjustment" of the portio cervicis with a vaginal speculum, the ostium externum cervicis uteri was cleaned with a piece of dry gauze. A portion of the mucus in the cervical canal was then carefully withdrawn into a glass pipette. From this a small drop, with a diameter of approximately 3 mm., was placed on a glass slide. A drop of fresh semen of approximately the same size was then placed beside the cervical mucus. The distance between the two drops had to be approximately 3 mm. A coverslip was then laid carefully on the two drops, care being taken to prevent lateral movement. Under the weight of the coverslip, the surface of the two drops became larger and within a given zone semen and cervical mucus came into contact. This contact zone was observed microscopically over a period of time.

When normal fertile semen and normal cervical mucus obtained during the period of ovulation were used, the authors saw after a short time that the spermatozoa in the semen arranged themselves along the contact zone in rows, two to four deep. The heads of the spermatozoa in these rows were directed towards the boundary line.

A short time later, they saw that at various points the boundary line between cervical mucus and spermatozoa was crossed by small

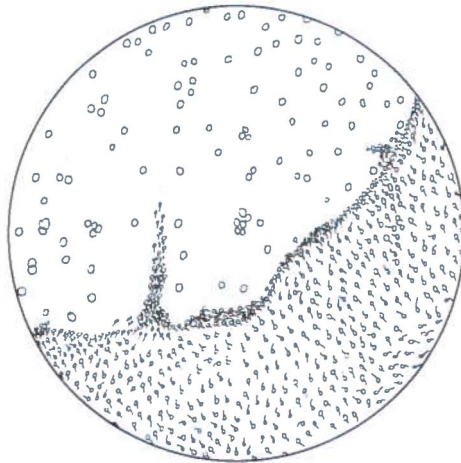

Fig. 1. Contact between semen and cervical mucus. Orientation and beginning penetration by means of phalanxes.

groups of spermatozoa. Each group formed as it were a spearhead for which the authors used the term phalanx (fig. 1). These phalanxes penetrated more and more deeply into the cervical mucus. It was noticeable that during their advance, the spermatozoa tended to remain, as far as possible, in contact with the side walls of the pyramid within which they moved forward. It was as if they were "scanning" the walls of the enclave for a weakness through which to penetrate the cervical mucus afresh. At certain points this was achieved and at such points a number of spermatozoa "dropped out of the column" to form a side phalanx (fig. 2). As a result of this system of ramified advance, a large number of spermatozoa could penetrate the cervical mucus in a short time. After a certain period, however, this *arborisation* ceased and the spermatozoa lost their motility. The authors attributed this to the fact that the penetration took place *in vitro*. When the cervical mucus was of high viscosity or contained a large number of leucocytes, no penetration of spermatozoa occurred.

In the publication of MILLER and KURZROK, the possibility of a *cross matching technique* was also mentioned. In this modification, the cervical mucus of the wife in question is tested against semen of a fertile man. The semen of the husband can also be tested against

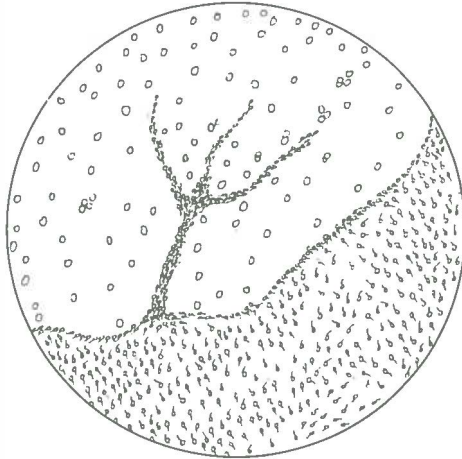

Fig. 2. Advanced penetration of spermatozoa in cervical mucus. Forming of side phalanges.

normal cervical mucus obtained during the ovulation period from a fertile woman. It could happen that in this test the spermatozoa of the husband, although morphologically normal, did not penetrate the cervical mucus of the wife, while the spermatozoa of another man did penetrate. The possibility of *incompatibility* between spermatozoa and cervical mucus was thus already established by MILLER and KURZROK. The reason for this incompatibility is still not clear. There has been mention of blood-group incompatibility (BEHRMAN 1961) or of the existence in the woman of antibodies directed against spermatozoa (NAKABAYASHI *et al.* 1961, FRANKLIN and DUKES 1964).

MILLER and KURZROK (1932) and before them, SEELIGMANN (1896) and STRASSMANN (1903), imagined that the spermatozoa, as a result of physico-chemical properties, were "drawn" out of the semen in the direction of the cervical mucus. For this, the term *chemotaxis* was used. MILLER and KURZROK were of the opinion that this chemotaxis was due to a difference in electrical potential between cervical mucus and spermatozoa.

This hypothesis was disputed by PERLOFF and STEINBERGER (1963). Using the MILLER-KURZROK test, they combined the ejaculate from a case of azoospermia with cervical mucus containing many highly motile spermatozoa. Via the contact zone, the spermatozoa crossed

from the cervical mucus into the spermatozoa-free ejaculate. This makes chemotaxis in the direction of the cervical mucus seem unlikely.

The formation of a phalanx was considered by MILLER and KURZROK as being the result of spermatozoal activity. PERLOFF and STEINBERGER (1963) showed, however, that this phalanx formation also occurred in cases of azoospermia. They were able to render this visible by the addition of a dye (Indian ink) to a spermatozoa-free ejaculate and by performing the MILLER-KURZROK test with this material. From this it appeared that such phalanx-formation is a physical phenomenon which is due to the filling up of "inlets" in the cervical mucus.

Penetration of the spermatozoa into the cervical mucus, according to Miller-Kurzrok, would occur through a lytic enzyme present in normal semen. In 1958, hyaluronidase, which occurs in normal semen, was considered by Kurzrok and Birnberg to be that lytic enzyme. They hypothesized that hyaluronic acid was present in cervical mucus and thus would be hydrolyzed by hyaluronidase. This hydrolysis would promote sperm penetration.

The investigations of Gibbons (1959) and of Werner (1959) have shown, however, that cervical mucus contains no hyaluronic acid and that hyaluronidase cannot reduce the viscosity of cervical mucus. The basic component of cervical mucus is a *glycoprotein* and not a *mucopolysaccharide*.

Neuhaus and Moghissi (1962) showed that proteolytic enzymes such as trypsin and chymotrypsin could hydrolyse the glycoprotein in cervical mucus and thus reduce the viscosity. The presence in semen of an enzyme (or enzymes) whose activity can be compared with that of trypsin and chymotrypsin had already been demonstrated in 1942 by Huggins and Neal. Lundquist *et al.* isolated this tryptic enzyme from semen in 1955 using ammonium sulphate.

In 1964 it was established by Moghissi *et al.* that phalanx formation occurred immediately after two liquids, with a comparatively large difference in viscosity, were brought into contact. In the Miller-Kurzrok test therefore, phalanx formation did not occur if the cervical mucus was diluted in advance with physiological saline or if its viscosity was reduced by the addition of a small quantity of chymotrypsin. An obvious boundary line along which the spermatozoa arranged themselves in rows no longer existed. Spermatozoal penetration then took place on a massive scale. Again, when cervical mucus obtained during the ovulatory phase had a very low viscosity, very little or no phalanx formation occurred. The spermatozoa crossed immediately from the semen into the cervical mucus.

However, when the viscosity of the cervical mucus was high, phalanx formation always occurred and an obvious boundary line existed. After 10-15 minutes, this boundary line became less distinct and less resistant

to spermatozoa, through the influence of the proteolytic enzymes from the semen. They then saw the spermatozoa cross the boundary line from the semen even between the points where phalanxes had been formed.

Moghissi *et al.* produced the following theory on the basis of their observations:

Phalanx formation and the proteolytic activity of the semen should be considered as auxiliary mechanisms for spermatozoal penetration. These auxiliary mechanisms come into action whenever the cervical mucus has a high viscosity. The inlets form refuges, as it were, into which the spermatozoa can withdraw from the harmful effects of the vaginal contents. The semen which has penetrated into these "crypts" then has more than sufficient time to weaken the cervical barrier by its proteolytic properties, without the spermatozoa being damaged during this period by admixed vaginal contents.

If the viscosity of the cervical mucus is low, these auxiliary mechanisms do not come into action. The spermatozoa then immediately penetrate far into the cervical mucus. This agrees with the observations of Sobrero and MacLeod (1962). These investigators had the opportunity of performing post-coital tests on 47 women in the ovulatory phase within 90 seconds to 3 minutes after ejaculation. It appeared that in 39 women spermatozoa could be found in the mucus of the endocervix. Whether the women had had an orgasm or not was immaterial.

It is remarkable that in the publications of PERLOFF and STEINBERGER the investigations of BARTON and WIESNER (1946) are not mentioned. For their experiments, these workers used a modified MILLER-KURZROK test:

A drop of cervical mucus was placed on a glass slide. This drop was surrounded by a "wall" of vaseline in which there were four small openings. Between the cervical mucus and the vaseline was a free zone. A clean coverslip was carefully laid onto the vaseline and in front of one of the openings a drop of semen was placed. The semen was drawn inside the "fence" by capillary attraction, while the air had the opportunity to escape through the other openings. The openings were then closed by a small quantity of molten vaseline. When the correct quantities were chosen, the whole reservoir was filled without the semen mixing with the cervical mucus. This permanent separation of the two media was a result of the difference in viscosity. The line of separation was clearly visible both macroscopically and microscopically.

The advantage of this method over the original MILLER-KURZROK test was that *drying up* of the material could be prevented, enabling observation to be carried out over a much longer period.

On the basis of their observations with this technique, Barton and Wiesner, as early as 1946, came to the conclusion that the chemotaxis theory was improbable. They found that after a time a number of spermatozoa which had penetrated into the cervical mucus returned to the semen. They also showed that phalanx-formation is not the result of active penetration of the spermatozoa, but is caused by the passive filling of "crypts" on the surface of the drop of cervical mucus. They did this in the same way as Perloff and Steinberger, but used carmine red instead of Indian ink.

The MILLER-KURZROK test has proved its worth in fertility investigations through the years and is still used in many gynaecological clinics.

There are, however, certain objections to the MILLER-KURZROK test. In the first place, it is often impossible to obtain a sharp boundary line between cervical mucus and semen. Frequently, part of the semen does not make contact with the cervical mucus or runs over it as the coverslip is placed on top (pseudo-penetration). A second objection is that the boundary line is not in fact a line but a plane. The area of this boundary plane is dependent on the viscosity of the cervical mucus. When this is high, the weight of the coverslip will cause the cervical mucus to spread out to a much smaller extent than when the viscosity is low. The spermatozoa are therefore offered a much larger penetration area when the viscosity of the cervical mucus is high, than when the viscosity is low. This makes comparison of mucus specimens with differing viscosities impossible. A third objection is that the MILLER-KURZROK test is inaccurate as a quantitative method for determination of spermatozoal penetration.

To answer these objections, GUARD (1960) proposed using the counting chamber of Levy's haemocytometer to perform the MILLER-KURZROK test (fig. 3). The cervical mucus was placed in the central groove (2) and spread out under the coverslip (1) by capillary attraction. The same capillary attraction prevented the cervical mucus from spreading out beyond the edge of the inclined plane (4). By means of a small pipette, a small quantity of semen was introduced onto the inclined plane (5). In this way, a boundary plane of constant area existed between semen and cervical mucus.

As soon as cervical mucus and semen came into contact with one

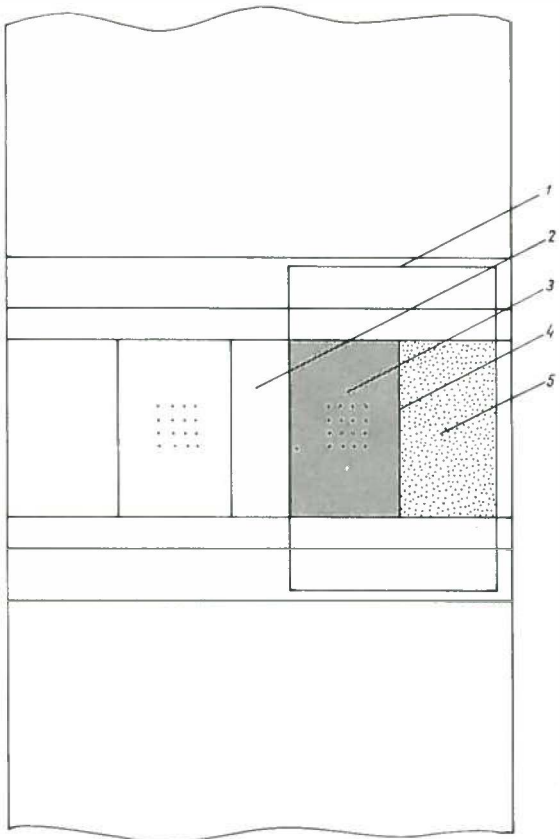

a.

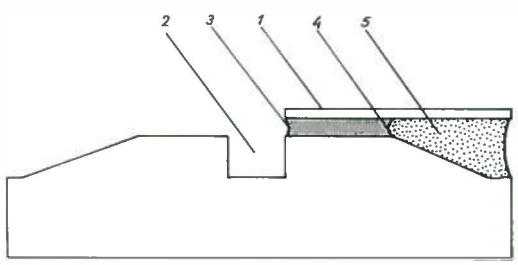

b.

Fig. 3. Top view (a) and side view (b) of Levy's double Neubauer haemocytometer. See text for figures.

another, penetration by the spermatozoa was seen to begin. Phalanx formation was not mentioned by GUARD. After 5 and 15 minutes, the number of spermatozoa per mm^3 cervical mucus was counted, making use of the small squares intended for counting leucocytes in blood examinations. However, this was only possible in cases of oligozoospermia. Normally in cases of normospermia, too large a number of actively motile spermatozoa was present in the cervical mucus to make an accurate count possible.

GUARD recommended that, during the period between the first and second counts, the counting chamber be placed in a Petri dish with moist filter paper. This was to prevent its drying up. Besides cervical mucus, use could also be made of other materials, e.g. physiological saline, Ringer-Locke solution, tears, saliva, nasal mucus, etc. With Ringer-Locke solution especially, the spermatozoa appeared to penetrate extremely well, indeed considerably better than into cervical mucus obtained during the ovulation period.

Advantages of the GUARD method are a good permanent separation of the media brought into contact with one another, the existence of a boundary plane of constant area and the possibility of quantitative determinations. A fourth advantage over the original MILLER-KURZROK test which, however, is not mentioned in GUARD's article (1960), is the following:

In the MILLER-KURZROK test it is often difficult after a time to find the original contact zone between cervical mucus and semen. This boundary line becomes indistinct under the influence of the proteolytic enzymes from the semen. Besides this, the spermatozoa have then often penetrated into the cervical mucus in such large numbers that the "starting line" is also impossible to recognize. In GUARD's method this difficulty does not arise, since the contact zone between cervical mucus and semen in this case coincides with the boundary between the inclined plane and horizontal plane of the counting chamber.

The method described by GUARD also offers the possibility of determining the number of leucocytes per mm^3 of cervical mucus in the same test.

Performance of the penetration test as described by GUARD gives rise to difficulties when the viscosity of the cervical mucus is increased. The capillary force is then insufficient to fill the counting

chamber, so that the desired contact zone cannot be obtained. In such cases, GUARD recommended that the cervical mucus be placed not in the groove, but directly on the lines in the counting chamber. The coverslip is then laid on top of the drop of cervical mucus and gently pressed down, so that the mucus spreads out in the counting chamber. However, it is difficult using this method to obtain a complete, uninterrupted contact zone at the edge of the inclined plane. Because of this, the test described by GUARD either cannot be used in a number of cases with increased viscosity of the cervical mucus, or produces unreliable results. And it is often just in these cases that it is important to know to what extent the increased viscosity of the cervical mucus hinders the penetration of the spermatozoa.

Despite the fact that a number of improvements are obtained by the modifications of the MILLER-KURZROK test as described by BARTON and WIESNER or by GUARD, these tests are still unsatisfactory in various respects.

In the first place, the distance which the spermatozoa have penetrated into the cervical mucus after a given time cannot be determined. The spermatozoa will not always progress in the same direction. The distance covered per unit of time, however, is an important factor, since from this the *qualitative motility* of the spermatozoa is determined. This last plays an important role in bringing about conception. MACLEOD and GOLD compared the qualitative motility of spermatozoa with several other important properties of semen, viz. volume of ejaculate, spermatozoal density, quantitative motility and spermatozoal morphology. From this it appeared that there was a closer relationship between qualitative motility and chance of conception than was the case with any of these other properties of semen (MACLEOD and GOLD 1953).

SILLÓ-SEIDL (1963) also came to the conclusion that the qualitative motility of spermatozoa was much more important for assessment of fertility than was the quantitative motility.

Thus a requirement for a good in vitro spermatozoal penetration test must be the possibility of exact determination of the qualitative motility.

In the second place, using the above-mentioned modifications of

the MILLER-KURZROK test, no reliable impression can be obtained of the *motility period* of spermatozoa under more or less physiological conditions. When the preparations are stored in moist surroundings at a temperature of 37° C, drying-out occurs quite rapidly in the test described by GUARD, unless the filter paper in the Petri dish is frequently moistened, while in the test described by BARTON and WIESNER the vaseline loses its consistency, causing leakage from the enclosed space.

The motility period under physiological conditions, however, is of importance in assessing the chances of conception, since in man coitus and ovulation are not synchronised via the hypothalamus and hypophysis as is the case, for example, in the rabbit and cat. For this reason, spermatozoa must maintain their motility in the genital tract of the woman for some days, since the non-fertilised ovum has a life-span of only a few hours. If the motility period of the spermatozoa in the genital tract of the woman is drastically reduced, then only a coitus taking place shortly before ovulation occurs can bring together motile spermatozoa and a living ovum in the tuba.

It is therefore important, that *a good in vitro spermatozoal penetration test should, inter alia, also offer the possibility of determining the longevity of the spermatozoa.*

The method of SILLÓ-SEIDL (1963) in which the spermatozoa are maintained in the undiluted ejaculate at a temperature of 20° C, appears to me less suitable for determining the longevity of spermatozoa under physiological conditions. Where the spermatozoal density is high, because of concentration of metabolic by-products, the motility will decrease more rapidly than where the spermatozoal density is low at least when one is dealing with "equivalent" spermatozoa in the two ejaculates. This is due to the fact that the concentration of metabolic by-products which have an adverse effect on the motility of the spermatozoa, builds up more quickly in the first instance than in the second. Even immediately after ejaculation materials may also be present in the semen plasma which adversely influence the motility (ROZIN 1960, 1961).

B. Capillary methods

It is possible to investigate the three important properties namely, the *penetration density*, the *qualitative motility* and the *longevity* of spermatozoa with the spermatozoal penetration test if, instead of a *coverslip method*, use is made of a *capillary method*.

The first publication dealing with this technique came from LAMAR *et al.* in 1940. They utilized glass capillaries with an internal diameter of 0.1-0.4 mm. A small quantity of cervical mucus was sucked up into these, followed by an air bubble and then by a small quantity of fresh semen. The glass capillary hence contained a column of cervical mucus and a column of semen separated by a small air bubble. The small air bubble was required to prevent mixture of mucus and semen and to provide a clearly visible boundary between the two liquids. Provided that the air bubble was small enough, sufficient mucus was left adhering to the wall of the glass capillary to ensure a contact zone between cervical mucus and semen. By placing the capillary under a microscope, the penetration of the spermatozoa into the cervical mucus could easily be observed. With this test it could be established that the distance covered by spermatozoa in cervical mucus varied from 1 to 3 mm. per minute. The *duration of motility* of spermatozoa which had penetrated into the cervical mucus was 20-30 hours. No mention was made of the temperature at which this duration of motility was determined. The above-mentioned values were only found when use was made of normal fertile semen and when the cervical mucus was taken between the 10th and the 15th day inclusive of the cycle of a fertile, sexually-mature woman with a regular cycle of approximately 28 days. Before the 9th and after the 19th day, the cervical mucus appeared to be impenetrable or only slightly so for spermatozoa. Spermatozoa which had succeeded in penetrating generally had a motility period of less than 2 hours.

In 1954 and 1955 SCHWARTZ and ZINSER described a modification of the capillary method developed by LAMAR *et al.* Semen and cervical mucus in their technique were no longer separated from each another by an air bubble in the glass capillary. The glass capillary, which was closed at both ends, was maintained at a temperature of 37° C under a microscope, the viewing stage being set in a vertical position.

From their investigations it appeared that, with a quantitative motility of more than 25 per cent, spermatozoa moved upwards in Ringer's solution. Where the motility was less than 25 per cent, there was no upward but rather a downward displacement of the spermatozoa. The distance covered after 2 hours by the spermatozoa in cervical mucus averaged 7.5 mm (observations from 25 cases, in which the quantitative spermatozoal motility in the semen was greater than 25 per cent). The distance covered per unit of time was thus much shorter than that registered by the method described by Lamar *et al.* Again in contrast to the observations of Lamar *et al.*, no relationship was found between the penetrability of the cervical mucus and the period of the cycle from which the cervical mucus was taken. In the article of Schwartz and Zinsser, no investigations are reported on the period of motility of spermatozoa in cervical mucus or Ringer's solution.

In the above-mentioned capillary methods, it was found to be extremely difficult to suck up semen and cervical mucus one after the other into the same glass capillary, because of the viscosity difference between the two liquids. For a time, the present author attempted to employ this method for performing the spermatozoal penetration test *in vitro*. With cervical mucus as medium, this only appeared possible when the cervical mucus had a low viscosity. The technique was therefore abandoned at an early stage.

In 1956 BOTELLA-LLUSIA described the results obtained by a Spanish-Mexican group of workers with the spermatozoal penetration test *in vitro*, using a modification of the capillary method. The most important difference from the capillary methods already described was that semen and cervical mucus (or another medium) were each placed in a separate reservoir. The test was performed as follows:

A small quantity of semen was pipetted into the cavity of a hollow-ground glass slide. A glass capillary filled with cervical mucus or with Ringer's solution (to which glucose, fructose or galactose could be added) was sealed at one end with paraffin and the other end was placed in the drop of semen on the glass slide, in a horizontal or vertical position. The whole system was incubated at 37° C for thirty minutes. The capillary was then examined microscopically to see how far the spermatozoa had penetrated into the medium in question.

With normal fertile semen and the glass capillary in a horizontal position, the depth of penetration was found to be greatest into Ringer-fructose solution (27.4 mm.) and least into pure Ringer's solution (7.1 mm.). The depth of penetration into Ringer-glucose and cervical mucus was approximately the same, being 22.3 and 20.9 mm. respectively. When the glass capillary was in a vertical position during incubation, the depth of penetration into all the solutions was approximately 30 per cent less. When the semen employed was less than optimal as regards its three main qualities, viz. spermatozoal density, spermatozoal motility and the percentage of morphologically normal forms, the depth of penetration into the various media was also found to be reduced. An obvious, statistically-determined correlation between the main qualities mentioned above for semen, (which together determine the fertility) and the depth of penetration into various media could not be shown. This was, however, hardly to be expected. The depth of penetration is the distance which the most far advanced spermatozoon has covered in a certain unit of time. It may happen, however, that only a very small number of qualitatively highly-motile spermatozoa penetrate deep into the medium in question, while the great majority remain far behind. Again, with a sample of semen of low spermatozoal density but good motility, a normal depth of penetration may be expected. For fertilization of an ovum, however, it is necessary that not a few, but a large number of spermatozoa reach the higher sections of the female genital tract. The linear progression in the glass capillary cannot therefore be taken as a measure of the fertility of the semen specimen. However, it may be expected that a positive correlation exists between the *number* of spermatozoa which have penetrated after a certain time a given distance into the medium in question and the chance of a conception occurring.

To determine the *quantitative penetration*, a 2 cm. long cannula with an internal diameter of 1 mm. was attached to an injection syringe; 0.2 cc glucose Ringer or cervical mucus was drawn up and the open end of the cannula brought into contact with the drop of semen on the glass slide. After incubation for two hours at 37° C, the number of spermatozoa that had penetrated was determined using the counting chamber of a haemocytometer.

Thirty semen specimens were investigated, 15 fertile, 5 subfertile and 10 sterile. For normal fertile semen, the number of spermatozoa that had penetrated was always found to be greater than 10,000 (varying from 10 to 120 thousand). When subfertile semen was used, this number lay between 250 and 9000. When semen of sterile men was used, absolutely no penetration occurred. This last fact is remarkable since in this latter group semen specimens were found with a spermatozoal density of 10-15 million, a quantitative motility of 2-56 per cent and a percentage of normal spermatozoa of 22-90 per cent. In the paper mentioned above, no comment is made on this finding.

In 1958, at a colloquium in Paris, a modification of the quantitative penetration test was described by BOTELLA-LLUSIA. The hollow-ground glass slide was replaced by a test tube into which the injection syringe was placed with the open end of the cannula in a small quantity of semen at the bottom of the test tube (fig. 4).

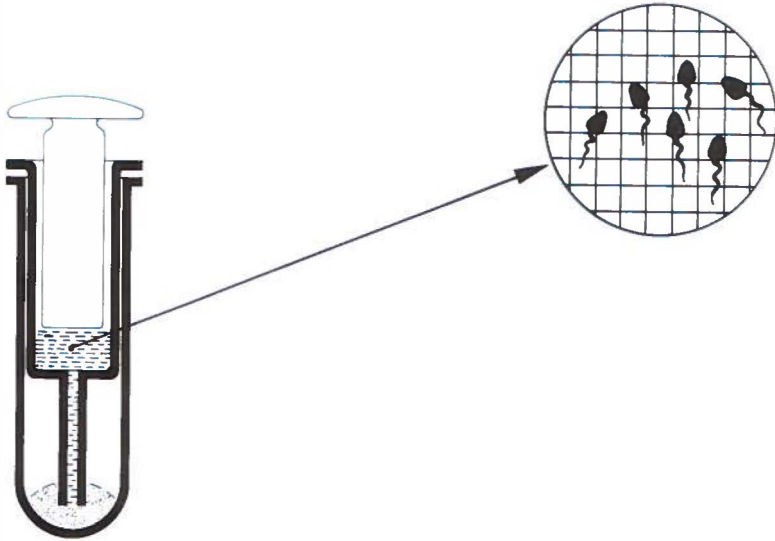

Fig. 4. Apparatus for performing the quantitative spermatozoal penetration test according to Botella-Llusia (1958). See text.

This apparatus was placed in the oven for two hours at a temperature of 37° C.

By means of this method, too, it was found that a quantitative penetration of 10,000 spermatozoa into Ringer-glucose or into normal ovulatory cervical mucus, is a minimum value to ensure normal fertility.

In 1962 RUIZ-VELASCO described the results of the quantitative penetration test using normal and pathological cervical mucus taken during and outside the ovulation period. In the interval, the apparatus had been further perfected. For withdrawal of the cervical mucus from the cervical canal, use was made of a syringe to which a small rubber tube and a pipette were attached. It was found that a positive correlation existed between quantitative penetration on

the one hand and the degree of flow elasticity (Spinnbarkeit) and fern formation on the other (see page 37-39). It was also found that, of the spermatozoa which had penetrated into the cervical mucus, the percentage of abnormal forms was considerable lower than in the semen. This same fact was also described in 1955 by BERGMAN for the SIMS-HUHNER test.

RUIZ-VELASCO assumed, therefore, that cervical mucus is a kind of *filter* for the spermatozoa.

BERGMAN and GENNSER (1959) and BERGMAN and FERBAS (1961) reported the results of a Swedish group of workers using the quantitative penetration test as described by BOTELLA-LLUSIA *et al.* Use



Fig. 5. Tuberculin syringe for sperm migration test, according to Bergman and Gennser (1959). See text.

was made of a tuberculin syringe attached to a stand (fig. 5). Into the syringe 0.2 cc. of a buffered isotonic fructose solution was drawn.

The test was performed at room temperature and after one hour, the number of spermatozoa that had penetrated was determined by means of the counting chamber described by BÜRGER.

Within the framework of the sterility investigation, the ejaculates from a total of 100 different men were investigated. A positive correlation was found to exist between the main qualities of the semen and the number of spermatozoa penetrating. It appeared that penetration by more than 10,000 spermatozoa took place only when the semen specimen in question contained at least 27×10^6 spermatozoa per cc ejaculate, when the motility was at least 50 per cent, and when less than 50 per cent of morphologically abnormal forms were present. Of the semen specimens which did not satisfy these three criteria, not a single one showed a penetration of more than 10,000 spermatozoa.

Both in the quantitative penetration test described by Botella-Llusia *et al.* and in that described by Bergman *et al.*, penetration by more than 10,000 spermatozoa seemed to be the criterion of normal semen. The points of difference shown by these two tests, viz. a difference in the medium used, a difference in temperature and a difference in duration, therefore appeared to have no effect on the end result.

The fact that the number of spermatozoa which penetrated into the Ringer-glucose solution during the two hours of the test of Botella-Llusia *et al.* is equalled in the shorter test described by Bergman *et al.* may be due to better penetration into the fructose solution used by the latter workers. That a fructose solution gives better penetration than a glucose solution was also shown by Botella-Llusia *et al.* (1956).

SALVATIERRA and SUREDA in 1958 described an apparatus for the determination of linear spermatozoal penetration. Penetration took place at 37° C. in the horizontal or vertical position using an isotonic glucose or fructose solution as medium. After thirty minutes the capillary was examined under the microscope and the linear progression of the spermatozoa determined.

It was found that of 62 semen specimens with a spermatozoal density of at least 20×10^6 per cc, a motility of at least 40 per cent and a percentage of morphologically normal spermatozoa of at least 80 per cent, all showed a linear penetration of more than 8 mm. (9-38 mm.) in the horizontal position and more than 3 mm. (4-19 mm.) in the vertical position. In 72 semen specimens failing to attain one or more of the above mentioned basic criteria, the linear penetration was less than 9 mm. in the horizontal position and less than 4 mm. in the vertical position.

According to SALVATIERRA and SUREDA, their glass capillary penetration test could replace the classical semen analysis for assessing the fertility of a semen sample.

This conclusion, therefore, does not agree with that of BOTELLA-LLUSIA *et al.*, who considered linear progression insufficient for assessment of the fertility of a semen specimen.

In 1961 SMITH and NEUMAN described a capillary penetration test, with the aid of which the linear as well as the quantitative penetration could be determined. A small polyethylene tube no. 200, with a length of 6 cm. and an internal diameter of 1.4 mm., was filled with physiological saline solution or with Locke's solution. One end was fitted with a small clamp and the other end was placed in the semen under investigation, at a temperature of 37° C. After one hour, the small tube was placed in the deepfreeze or the contents were frozen using liquid nitrogen. The tube was then cut up into lengths of 1 cm. These pieces were numbered and then allowed to thaw. The number of spermatozoa in each segment was determined in the counting chamber of a haemocytometer.

A clear connection was found between the qualitative motility of the semen on the one hand and the linear and quantitative penetration on the other.

The spermatozoal density in a relatively large number of cases did not correlate with the linear and quantitative penetration. The possibility of a connection between penetration and the morphology of the semen was not investigated.

As already mentioned the capillary method offers advantages over the coverslip method for performance of the spermatozoal penetration test *in vitro*.

In the first place by using the capillary method, the *linear progression* of the spermatozoa can be determined, which is not possible with the coverslip method. In this way one of the most important properties of spermatozoa, namely the *qualitative motility*, can be determined with great accuracy. The *quantitative progression* can be determined with the coverslip method as described by GUARD (1960) or with the capillary method as described by BOTELLA-LLUSIA *et al.* (1956, 1958, 1960), BERGMAN *et al.* (1959, 1961), or by SMITH and NEUMAN (1961).

The second advantage of the capillary method over the coverslip method is the possibility of determining the *duration of motility* of the spermatozoa in the medium in question, because evaporation of

fluid out of the capillary tube can easily be prevented by closing the open ends of the tube.

The duration of motility is a useful criterion for assessment of the *longevity* of the spermatozoa.

Of the capillary methods described, that of BOTELLA-LLUSIA *et al.* is of most value because, with this, the quantitative penetration can be determined. This quantitative penetration appears, from the investigations of BOTELLA-LLUSIA *et al.* as well as those of BERGMAN *et al.*, to be a reliable *fertility index*. The quantitative penetration test described by BOTELLA-LLUSIA *et al.*, however, also has some disadvantages.

In the first place, linear progression is less easily determined than by using a simple glass capillary. Improvements could be made by making the cannula of the syringe longer and of transparent material. By bringing the syringe with the cannula under the object lens of a microscope at different times, the linear progression could be measured. This is however rather inconvenient, besides which the quantitative penetration may possibly be disturbed by this treatment.

A second disadvantage of the quantitative penetration test as described by BOTELLA-LLUSIA *et al.* is that an air bubble or a small mucus plug in the cannula can hinder penetration. This objection could also be avoided by making the cannula of transparent material. Any possible obstruction could then be removed before beginning the test.

A third objection, which will be more difficult to rectify, is that when only a very small quantity of cervical mucus is available, it will be impossible to draw 0.2 cc. into the syringe.

In the fourth place it is difficult, if not impossible, when using cervical mucus, to suspend the spermatozoa homogeneously in the mucus after penetration. This is nevertheless essential, since otherwise no reliable determination of the number of spermatozoa penetrating can be obtained.

Finally, the method of BOTELLA-LLUSIA *et al.*, although reasonably simple to perform, still requires a number of handling procedures which make this test less suitable for routine investigations. If complete semen analysis were rendered superfluous by this test, then this last objection would no longer exist. This, however, is not the case, since one needs to know not only *whether* the semen is of

reduced fertility or non-fertile, but also *why* this is so. An answer to this latter question is important in determining therapy.

It therefore occurred to the present author that the spermatozoal penetration test *in vitro* required a method other than those so far described. To this end, he has developed a simple, easily manipulated little apparatus, with which the *depth of penetration* (linear progression), the *penetration density* (quantitative penetration) and the *period of motility* (longevity) of the spermatozoa can be determined in the medium in question.

The construction of this apparatus, called *sperm penetration meter* (hereafter referred to as the S P M), is extremely simple and requires so little time that several of these little devices can be produced at any glass-worker's bench, whenever required.

Performance of the *in vitro* spermatozoal penetration test with the sperm penetration meter (hereafter called the S P M test) is just as simple and rapid. Unskilled laboratory personnel can also be permitted to perform the test by this method. And further more, when only a small quantity of semen or a small quantity of cervical mucus is available, the test can be performed with the sperm penetration meter. For this only two drops of semen and less than 0.05 cc. cervical mucus are required.

The performance of the S P M test was published in a preliminary paper (KREMER, 1965) and will be described in detail in Chapter II.

chapter 2

the SPM test

A. *Construction of the S P M*

A small test tube with a length of approximately 7 cm. and an external diameter of approximately 8 mm. (a so-called serum tube, often used for blood group investigation) is sawn length-wise for a distance of 1 cm. from the bottom by means of a rotating glass-saw. Care must be taken that the saw does not pass exactly through the middle of the tube, because then two identical halves are produced, which however, are both too small for the envisaged use (part of the glass, equivalent to the thickness of the glass saw, is removed). The test tube must be sawn in such a way that one of the side surfaces of the glass-saw passes exactly through the middle of the tube. The tube is then sawn through at right angles to the longitudinal sawcut at a distance of 1 cm from the bottom.

In this way two unequal bottom pieces, each with a length of 1 cm., are obtained. The bigger one is fixed onto a calibrated glass slide with glass glue, slightly above the mid-point of one of the short sides. The open section of the little reservoir formed in this way faces the other short side and runs parallel to it.

A glass rod with a length of 2 cm. and a diameter of 1 mm. is glued to the glass slide at a distance of 1 cm. from, and parallel to, the open section of the small glass reservoir. This rod need not be solid; a glass capillary can be used quite well.

The calibration of the glass-slide is performed using etching-ink. The calibration lines divide the length of the slide into centimetres and halfcentimetres. (fig. 6).

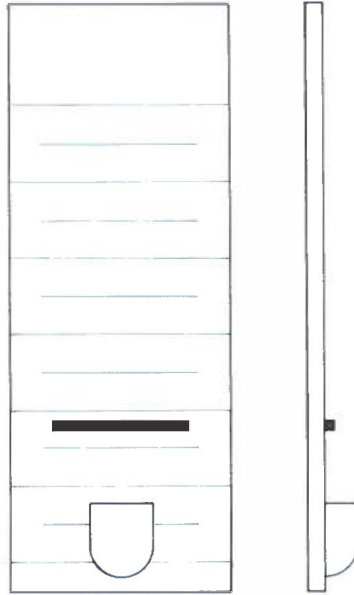

Fig. 6. Front and side-view of the sperm penetration meter (SPM).

Calibration of the slide with etching ink is not without its difficulties, since the etching ink tends to spread out, causing the lines to be broad and irregular. A thin layer of beeswax should therefore be applied in advance. In this the lines are drawn with a needle and the etching ink placed in these lines. In this way very thin, regular lines can be obtained.

Some experience is necessary before the technique of calibration with etching ink can be mastered. The first attempts nearly all result in failure. Technically it is easier to use transparent hard plastic, instead of glass. On this very thin lines can be drawn without difficulty with a needle. This material, however, has the disadvantage that it can become dull on boiling and is easily scratched.

B. *Obtaining and evaluating the materials necessary for the investigations*

a. *Acquiring and transporting the ejaculates*

The ejaculates used were from men who were enrolled, together

with their wives, for a fertility examination. The ejaculation generally took place in the couple's home. The disadvantage of this is that the ejaculate is often already several hours old by the start of the examination which can have an unfavourable influence on spermatozoal motility. However, it was virtually always possible to keep the time which elapsed between ejaculation and the start of the laboratory examination shorter than two hours. This is the period in which the spermatozoa in a normal fertile ejaculate maintain their initial motility (VASTERLING 1960). An important advantage of ejaculation in the couple's home is that the seminal emission is easier to bring about in a familiar environment and, in a number of cases, is more complete than when it has to take place in strange surroundings. The ejaculation took place in the clinic only in exceptional circumstances. This was the case when the couple's home was more than two hours' journey from the clinic.

Each man was given to take home a small, cylindrical, glass bottle with a volume of 30 ml. in which to put the semen. The bottle was made of thick, strong glass and could be closed with a screw-top. LANE ROBERTS *et al.* (1948) warned against the use of new glass, because they believed it impaired the motility of the spermatozoa. I could detect no difference in spermatozoal motility when part of a semen sample was kept in new glass, part in old glass and part in paraffined glass. After 8 and 24 hours the motility was found to be the same in all three bottles. This test was repeated five times, each time with the semen from a different man and each time with the same result.

Preferably, an ejaculate was used which had been obtained by *massaging the phallus*.

The term "masturbation semen" often encountered in the literature, should be avoided, not only because the term is ethically "charged" but also because it must be regarded as incorrect in these circumstances. The only purpose of masturbation is to generate an orgasm. The resulting ejaculate is an undesired side effect. Bringing about an ejaculatory reflex within the framework of a fertility investigation by rubbing the phallus is quite a different matter. Here the only purpose is to obtain an ejaculate; the orgasm is an unintended side effect.

Obtaining semen for a fertility examination by massaging the phallus can therefore be better compared to a coitus performed with the aim of inducing pregnancy. In fact in both cases the object of the act, direct or indirect, is *pregnancy*.

If the person concerned was too strongly inhibited to bring about the ejaculatory reflex manually, use was made of semen obtained after *coitus interruptus*. Of 3248 ejaculates examined during the period 1 July 1963-1 July 1967, 287 were obtained in this way.

The disadvantage of this is that the semen is more or less contaminated by the contents of the vagina. This contamination can be quite pronounced, especially when fluor albus is present. The presence of leucocytes, vaginal cells and Döderlein flora could be detected in the majority of the semen specimens obtained by *coitus interruptus*. In addition, the first part of the ejaculate is often lost with *coitus interruptus*. And it is precisely in this part that spermatozoal density and spermatozoal motility are greatest (MacLeod and Hotchkiss 1942, Farris and Murphy 1960, Amelar and Hotchkiss 1965).

Whenever the man had scruples about obtaining semen by massaging the phallus or by *coitus interruptus*, because of ethical or religious objections - this occurred seldom - the so-called *cervical spoon* was used (DOYLE 1948, SCHELLEN 1960).

Here the chance of contamination of the ejaculate by the contents of the vagina is considerably greater than with *coitus interruptus*. Spermatozoal motility is impaired in a number of cases, while the diagnosis of leucospermia cannot be made. Of 3248 ejaculates examined during the period 1 July 1963-1 July 1967, only 4 were obtained in this way.

Semen obtained by *coitus condomatosus* was never used.

The rubber of the condom is often impregnated with spermicidal substances which will interfere with any evaluation of spermatozoal motility.

Semen extruded from the vagina after normal *coitus* was also never used.

One of the disadvantages of this method, advocated by Holt, is that the total ejaculate is not obtained, and that spermatozoal motility can be impaired by mixing with the sometimes considerable amount of vaginal contents (Hellinga 1949). According to Holt, the latter is not the case. He found no rapid decrease in spermatozoal motility in 969 semen specimens extruded from the vagina immediately after *coitus* and then sent by express post to a central laboratory. 24 Hours later an average of about 50% quantitative spermatozoal motility was found in these specimens, while the majority of them came from infertile men (Holt 1956). I was not able to reproduce these favourable results with the Holt method, even with fertile semen samples.

It is important to give the husband clear instructions in advance as to how the semen must be collected and transported. For this, he was given, along with the receptacle, a form to be completed and handed in at the laboratory together with the semen. There were a number of instructions printed on the front page of the form. The laboratory data were filled in on the back page of the form.

The most important instructions were as follows:

The examination must be preceded by 3-5 days abstinence. Before ejaculation the penis must be washed well with water and dried thoroughly. Soap must not be used since traces of soap can impair spermatozoal motility.

The bottle must be brought to about body temperature before the emission; a sudden drop in temperature can cause an irreversible shock for the spermatozoa. If a part of the semen is lost, this must be mentioned on the form; it must also be made clear whether the first or last part of the semen has been spilled. To avoid bringing the semen into too much contact with air, which impairs spermatozoal motility, violent shaking must be avoided as much as possible during transport (Vassterling 1960).

If during the two months preceding the investigation, the husband has had *pyrexia, an allergic disease, a virus disease*, has used *drugs* or been operated on under *narcosis*, this must be mentioned on the form. Spermato-genesis can be unfavourably influenced by these factors (Mills 1919, Moore and Oslund 1924, MacLeod and Hotchkiss 1941, Brown 1943, MacLeod 1951, Nelson 1953, Nelson and Bunge 1957, MacLeod 1962, Scott and Young 1962, Charney 1962, Glover and Young 1963, Hellinga personal communication).

b. *Evaluation of the ejaculates*

The fertility evaluation of the ejaculates was based on:

- Spermatozoal density
- Quantitative motility of the spermatozoa
- Qualitative motility of the spermatozoa
- Morphology of the spermatozoa.

The *spermatozoal density* was determined with the haemocytometer. The semen specimen was thoroughly mixed and drawn to the 0.5 mark, halfway up the stem of the pipette. The pipette was then filled to the mark at the top of its bubble-chamber with a solution of 5% sodium bicarbonate in order to kill the spermatozoa. The bicarbonate solution had been coloured blue beforehand

by adding 3 drops of 1 % methylene blue to 10 cc. of the solution. This facilitated observation of the formed elements in the ejaculate. Counting was carried out with the BÜRKER counting chamber.

The *quantitative motility* of the spermatozoa was calculated according to an estimating method whereby the ratio is determined of the number of nonmotile to that of the motile spermatozoa in a number of visual fields. The estimated quantitative motility was given in multiples of 10 %. If the estimated value was less than 10 %, then a differentiation was made into 5 %, less than 5 % and sporadic.

The *qualitative motility* of the spermatozoa, i.e. the rate of movement, was also determined by estimation. Use was made of a number gradation, a method used by many American investigators (MACLEOD and GOLD 1951, DANEZIS *et al.* 1962).

The number gradation was as follows:

- 0 = no movement
- <1 = movement in situ
- 1 = slow progressive movement
- 2 = moderate progressive movement
- 3 = fairly good progressive movement
- 4 = good progressive movement
- 5 = very good progressive movement.

Since the qualitative motility can change in various visual fields, a number of such fields were always evaluated. In the various visual fields, the variation in qualitative motility amounts as a rule to less than one grade. These differences were indicated by adding the grading + or —. For example, if the motility was given by grade 2 in the majority of the visual fields, but as grade 3 in a minority, then the qualitative motility was indicated as 2+. A classification of 4— signifies that grade 4 motility was seen in most of the visual fields, and grade 3 in the remainder. When the spermatozoa were partly slow progressive and partly only motile in situ, this was indicated by grade 1—.

For evaluating *the morphology* of the spermatozoa a thin smear was made from every ejaculate on a microscope slide which was dried in air. This smear was fixed for five minutes in methyl alcohol, then stained for 15 minutes with a solution of 2.5 ml. Giemsa stain

in 80 ml. buffer pH 6.9, and subsequently dried in air. The preparations were examined microscopically under the oil immersion lens (magnification 10×100). The morphological classification was based on the shape of the spermatozoal head. Only the spermatozoa which were lying on the flat side of the head on the glass were included in the evaluation. A normal spermatozoon was regarded as one having an oval head with the separation between the foremost thin part of the head and the rear thick part of the head being indicated by a fairly sharp line roughly through the middle. The spermatozoa whose heads did not fulfil these requirements were classified as morphologically abnormal.

The *fertility grade* was indicated with the aid of a points system. The spermatozoal density, the quantitative motility, the qualitative motility and the morphology of the spermatozoa were indicated by points in the following manner:

Count in millions/cc	point value
0	0
<5 million	1
5—20 million	2
20—60 million	3
≥ 60 million	4
Percentage motile	point value
0	0
< 5 %	1
5—40 %	2
40—60 %	3
≥ 60 %	4
Grade of motility	point value
<1, 1—	0
1, 1+, 2—	1
2, 2+, 3—	2
3, 3+	3
4—, 4, 4+, 5—, 5	4

Morphology	point value
<20 % normal heads	0
20—50 % „ „	1
50—60 % „ „	2
60—70 % „ „	3
≥70 % „ „	4

The *fertility grade* of the semen was calculated on the basis of the total number of points obtained, using the following scale:

0 points = sterile
1—6 points = bad
6—11 points = poor
11—13 points = passable
13—16 points = good

c. *Collection of the cervical mucus*

Collection of cervical mucus from the cervical canal can sometimes give rise to difficulties. Some investigators, for example COHEN *et al.* (1952), recommend using a syringe with a long, blunt cannula. The portio cervicis uteri is initially brought into view with a speculum. My experience with this method is unfavourable. Only if a generous quantity of thin, liquid cervical mucus is present, can the suction method give good results. If there is a scarcity of cervical mucus, a quantity of air is often sucked in and this mixes with the mucus as small air bubbles. If the cervical mucus is of high viscosity, then it is completely impossible to withdraw it by suction.

Another method of obtaining mucus from the cervical canal is with the help of small dressing forceps. After the cervix has been focussed with the help of a self-holding speculum, the portio is cleaned with a dry gauze. The end of the forceps is then inserted into the cervical canal in a slightly open position, closed securely and withdrawn again. The cervical mucus held in the reservoir between the blades of the forceps is then smeared onto a clean glass slide.

This forceps method has the disadvantage that lesions are quite frequently produced in the cervical canal, especially when this is

narrow, or when the blades of the forceps are broad. As a result, the cervical mucus becomes contaminated with blood.

Again, when thin-bladed forceps are used, there is still frequent blood contamination in the cervical mucus. The longitudinal folds of the endocervix, forming the "arbor vitae", are easily caught between the blades of the forceps, because of which these cannot be withdrawn. When the forceps are slightly opened and then reclosed, bleeding from the damaged mucosa will render the cervical mucus less suitable for the investigation.

KERNER in 1953 described forceps with which cervical mucus could be taken from deep in the cervical canal, without also taking mucus from the distal part. It seems to me that even with this instrument, lesions can be avoided only with difficulty.

PALMER (1955) constructed modified dressing forceps, the closed concave blades of which formed a kind of hollow torpedo. The instrument was inserted closed, and then opened at the desired point within the cervical canal. The hollows then filled with cervical mucus, after which the forceps were closed. This instrument could be set aside for some time in the closed position without the cervical mucus drying out.

The construction of this instrument too, is such that mucosal lesions cannot always be avoided. I have therefore endeavoured to modify dressing forceps in such a way that, while a reasonable quantity of cervical mucus can still be obtained, the chance of lesions is minimal. I started from the hypothesis that the lesions generally occur because, when normal forceps are used, the mucosal folds from the cervical canal are caught between the ends and sides of the blades (fig. 7). To prevent this I had dressing forceps, with blades 7 mm. wide, ground down, so that the end and sides of the blades sloped inwards. As a result, the mucosal folds of the endocervix have less chance of being caught when the forceps are closed (fig. 8).

It is important, before introducing the forceps into the cervical canal, to clean the portio of possibly protruding cervical mucus with dry gauze. This mucus has been in contact with the vaginal contents and is therefore unsuitable for investigation. Normally, the protruding cervical mucus is somewhat turbid even when the mucus further in the cervical canal is clear. The mucus obtained from the

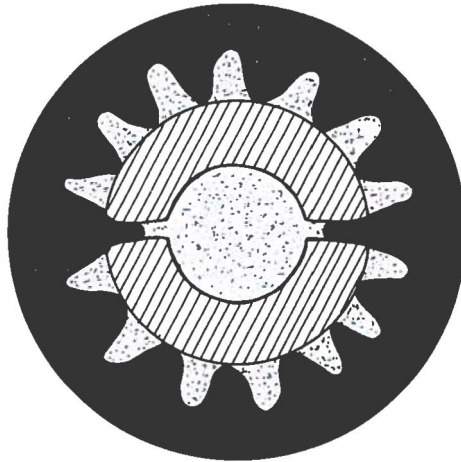

Fig. 7. Transverse section through the uterine cervix with the blades of normal dressing forceps "in situ". Mucosal folds of the endocervix (black area) are caught between the blades (lined area). Cervical mucus (dotted area) is situated between and around the blades.

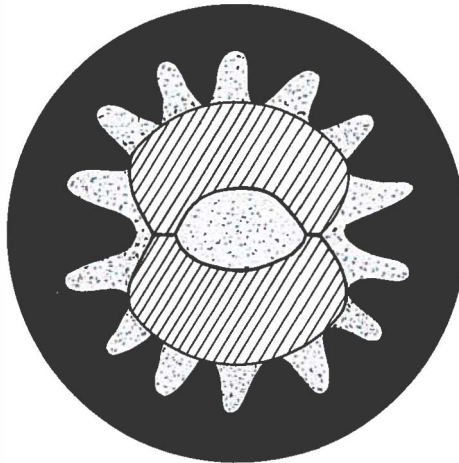

Fig. 8. Transverse section through the uterine cervix with the blades of newly designed forceps "in situ". There are no lesions of the endocervix, because the edges of the forceps blades slope inwards.

cervical canal, held between the clamped blades of the modified forceps, is afterwards smeared onto a clean slide. This requires some

skill since it is often difficult to remove the mucus from the blades of the forceps because of the fairly strong adhesion between the mucus and the metal of the forceps. The mucus must therefore be "smearred out" during the manipulation in such a way that the contact area between glass and mucus is rendered as large as possible.

Frequently, the instrument must be inserted into the cervical canal several times in order to collect sufficient material for the spermatozoal penetration test and also for complete examination of the cervical mucus.

The glass slide with the cervical mucus on it is immediately placed in a previously-prepared Petri dish containing a moist gauze. The name of the patient and the date of collection are recorded on the cover of the Petri dish with a wax pencil. A form with certain data is also attached, on which the technician can report the result of the investigation.

The Petri dish can be kept at room temperature for 1-2 hours in this way, without any notable drying out of the cervical mucus.

This method is also used in carrying out the SIMS-HUHNER test. (p. 88).

It proved that in this way the motility of the spermatozoa in cervical mucus remained unchanged for at least an hour. This is an advantage since the duties of the laboratory personnel do not always permit immediate performance of the SIMS-HUHNER test.

d. *Evaluation of the cervical mucus*

The evaluation of the suitability of the cervical mucus for penetration, migration and survival of spermatozoa was based on the following properties:

- Clarity
- Viscosity
- "Spinnbarkeit"
- Acidity
- Glucose test
- Fern test.

The clarity.

The assessment of this was given as follows:

Clarity grade I

Generally clear with perhaps here and there a turbid area.

Clarity grade II

Clear mucus with quite a number of turbid areas.

Clarity grade III

Generally turbid. Depending on the degree of turbidity, this group was subdivided as follows:

- a) somewhat turbid (hazy)
- b) reasonably turbid
- c) very turbid.

Clarity grade IV

Colour of the cervical mucus yellow-brown.

The viscosity.

The viscosity was determined with the consistometer as described by SCOTT BLAIR (manufactured by Arnold and Sons, 54 Wigmore St., London W.1). This consistometer shown in figure 9) consists of a small air reservoir connected to four valves (A, B, C and D). These valves are attached to a capillary tube (with a base of 5 mm.) at A, a pressure gauge at B, an outlet to the outside atmosphere at C and a small pump at D. Behind the capillary tube there is a scale, graduated in units of $\frac{1}{8}$ inch. The capillary tube is filled up to mark 4 on the scale with cervical mucus by drawing the piston of the pump slowly upwards, the grub-screw E being loose. During this procedure a subsample of the cervical mucus is held against the mouth of the capillary tube on a microscope slide. To measure the consistency, valve A is closed, B opened and a convenient pressure as recorded on the dial is built up within the reservoir. If the mucus is very viscous this pressure must be high; if the mucus is very fluid the pressure must be low. Finding the most convenient pressure for each mucus sample is a question of experience. Valve D is then closed and A opened. The secretion starts to flow out of the tube, forming a blob at the end. When the mucus passes the mark 5, a stop watch is started and the flow timed over $\frac{1}{2}$ inch (to mark 10). Since the pressure of extrusion is chosen simply from the appearance

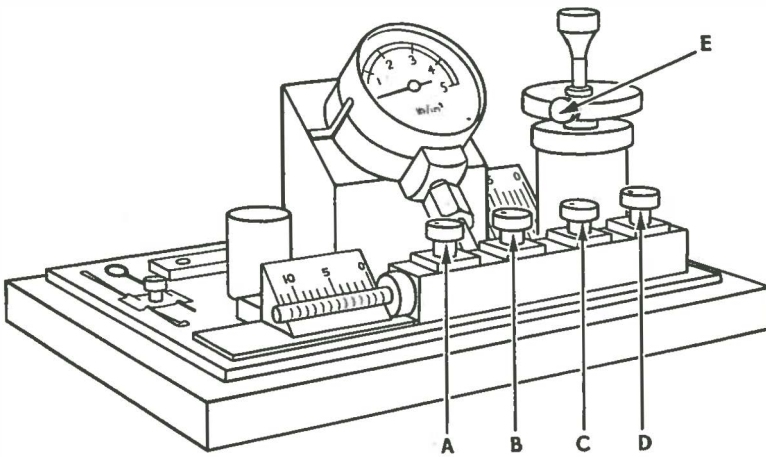
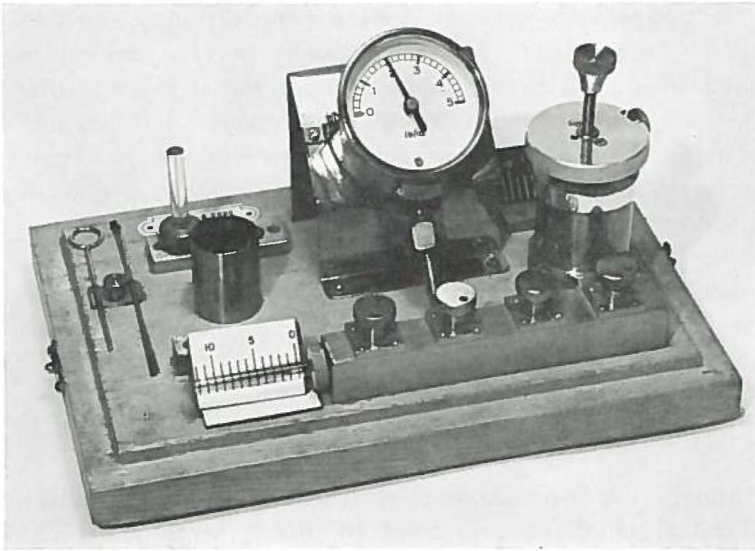

Fig. 9. Consistometer according to Scott Blair.

of the secretion and its behaviour in filling the capillary, the test is repeated twice at a different pressure and the shortest time obtained noted. Generally the three flow times do not vary much.

If cervical mucus was a simple fluid, the time of outflow (A) would be inversely proportional to the pressure (P) and the product

Pt , multiplied by a constant derived from the dimensions of the capillary tube, would give the viscosity. In fact cervical mucus behaves in a much more complex manner, but it is found that for values of t from about 5 to 60 sec., the product of P and the root of t is approximately independent of pressure, i.e. a scattergram plotting $\log P$ against $\log t$ for a number of tests on a simple sample, has a slope of about $1/2$. The value of $Pt^{1/2}$ is considered to be a suitable standard to indicate the viscosity of the cervical mucus in question. $Pt^{1/2}$ is readily calculated on a slide-rule or by means of a nomograph device, provided by the manufacturer of the consistometer.

The "Spinnbarkeit".

Although the "Spinnbarkeit" (elasticity, fibrosity, threadability) of cervical mucus is considered by many investigators as one of the most important properties for assessment of cervical mucus as a spermatozoal transport medium, determination of this property is generally undertaken in a rough-and-ready fashion, i.e. by stretching a drop of cervical mucus between two instruments, for example between a slide and a cover slip (COHEN *et al.* 1952, 1956), between a slide and the tip of closed smooth forceps (KLEEGMAN and KAUFMAN 1966) or even simply between the tips of two gloved fingertips. The inaccuracy of these methods is the result of the fact that the length of the drawn-out thread depends not only on the elasticity of the material but also on the volume of the drop of mucus and the degree of adhesion between the drop of mucus and the contact surface. If the drop of mucus is large and the mucus is easily detached from the surface, then during extension of the thread material is continually added to the beginning of the thread. In this way a much longer thread can be drawn than when a small drop of mucus is obtained.

For this reason, I developed another method in which the quantity of cervical mucus plays no role.

A glass capillary of approximately 6 cm. length and external diameter of 0.9-1 mm. is filled with the cervical mucus to be investigated. The capillary filled with cervical mucus is then sealed at both ends with a small lump of modelling wax and then broken at a point

approximately 1½ cm. from one end. The broken ends are then drawn apart slowly against a background marked with a millimeter scale. The length in mm attained at the moment the thread breaks is noted (fig. 10). The same procedure is repeated twice more, each

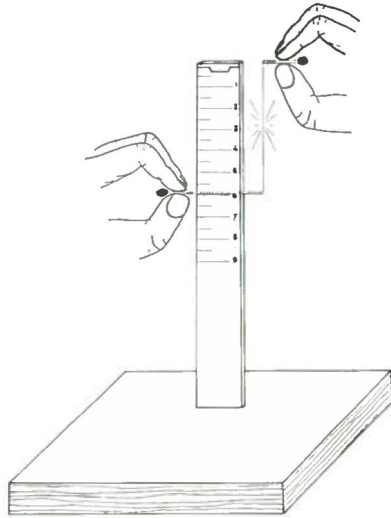

Fig. 10. Determination of the "Spinnbarkeit" of cervical mucus.

time at a distance of approximately 1½ cm. from the previous broken end.

The length of the longest of the three threads is considered as the "Spinnbarkeit" of the mucus sample in question. A much greater number of threads should really be drawn to be able to determine the "Spinnbarkeit" even more exactly. This, however, is impracticable, because then insufficient material would remain for the other investigations.

The acidity.

The acidity of the cervical mucus was determined by applying a small quantity to an Oxyphen paper strip.

The glucose test.

The presence of glucose in the cervical mucus was confirmed with

the aid of a paper strip method (Clinistix). Depending on the intensity of the blue colour produced on the paper, the result of the test was given as negative (no blue colouration), trace (slight blue colouration), + (widespread light blue colouration), ++ (widespread blue colouration of moderate intensity), +++ (widespread dark blue colouration).

The investigator should wait for five minutes before reading the test result.

The fern test

To perform the fern test, a portion of the cervical mucus was dried on a glass-slide. The preparation was then inspected microscopically at a magnification of 8×10 and with the condenser in the low position.

If the cervical mucus sample contained turbid or blood-contaminated areas, these were omitted as far as possible from the sub-sample on which the fern test was performed. If the mucus was completely mixed with blood, this was then obviously impossible. Such admixture with blood influences fern formation unfavourably, without influencing the motility of penetrated spermatozoa.

Whenever throughout or almost throughout the preparation a well-formed fern structure was observed, this was given the classification +++ (fig. 11). Where in a large part of the observed fields good fern formation was seen, this was classified as ++. Where fern structure was observed only here and there in the observed fields, the result was noted as +. No fern formation was noted as neg.

By normal cervical mucus from the ovulatory phase was understood cervical mucus of which the physico-chemical properties met the following criteria:

Clarity:	grade I or II
Viscosity:	<4
Spinnbarkeit:	≥ 30 mm.
Acidity:	7-8.5
Glucose test:	neg., trace, weak pos., +, ++ or +++
Fern test:	maximum positive (+++)

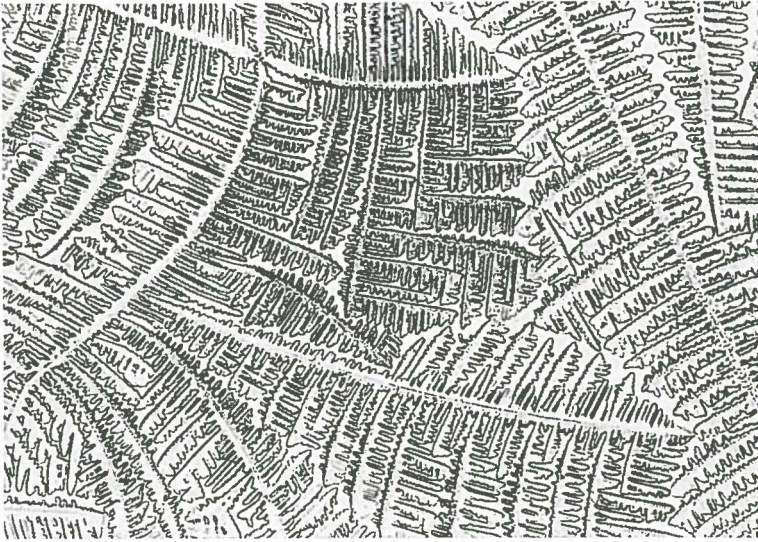

Fig. 11. Fern test in cervical mucus (x 200).

The above normal values were compiled on the basis of the result of an investigation into the physico-chemical properties of 100 cervical mucus specimens from the ovulatory phase of 100 different women in which spermatozoa with good progressive motility were found 2-8 hours after coitus (KREMER, publication in preparation).

On the basis of the investigations carried out by OGINO (1932), VOLLMAN (1940, 1953) and FLUHMAN (1957), the ovulatory phase of the cycle was regarded as constituting a period of three days from the 16th up to and including the 14th day before the first day of the next expected menstruation. With a cycle of less than 28 days, the midcycle day was regarded as the day of ovulation; this day and the two preceding days constituted the ovulatory phase.

e. Obtaining an alternative medium to cervical mucus

Finding a suitable medium as a substitute for human cervical mucus from the ovulation period turned out to be quite a problem. Fresh white of egg, the physico-chemical properties of which largely correspond to those of cervical mucus, was found to be unsatisfactory in practice. Penetration density as well as linear pro-

gression and duration of motility were considerably lower than was the case when human cervical mucus from the ovulation period was used.

Bovine cervical mucus, of which 100-150 cc. can be obtained in the estrus period, was found to be unsuitable. Immediately after penetrating this mucus human spermatozoa lost their motility.

Synovial fluid and aqueous humour from the eye also gave results which were not comparable with those obtained by the use of cervical mucus taken during the ovulation period of a normal fertile woman.

The results with solutions of gelatin, agar-agar and polyethylene derivatives were still worse.

On the basis of the investigations of ROZIN and ROZIN (1962), fresh human blood serum appeared most suitable. The relative clarity of this material made it possible to recognize clearly the penetrating spermatozoa as such, while the duration of motility of these spermatozoa actually exceeded that in cervical mucus. By addition of macromolecular materials, I attempted to increase the viscosity and "Spinnbarkeit" of the medium. For this I used mucopolysaccharides (hyaluronic acid and chondroitin sulphate) and human albumin. A good "Spinnbarkeit" could not be obtained with any of these products, however, and in other respects too, the addition of these materials offered no advantage. I therefore continued to use plain pure human blood serum as medium.

Theoretically, it would seem preferable to use serum obtained from a person with the same blood group as the man from whom the semen has been taken. Spermatozoa can possess blood group antigens (BEHRMAN 1961) by which the results of the spermatozoa penetration test could be influenced.

In the investigations of this thesis blood of blood group AB, Rh + was used. The serum was kept in the freezer. Serum from blood group AB is to be preferred since no agglutinins are present in it against A or B antigen.

Also serum from the wife was used, to check if the same results were obtained as with AB serum. One could well imagine that in a number of cases of so-called inexplicable sterility, the serum of the partner contains materials which adversely affect the spermatozoa of her husband.

C. *Performance of the S P M test*

With the aid of a Pasteur pipette, the small glass reservoir of the S P M is filled with semen to slightly below the rim. It would be ideal to be able to do this under aseptic conditions to prevent the occurrence of bacterial growth. Various types of bacteria have an adverse effect on the motility of the spermatozoa. Colibacteria and proteus vulgaris are particularly notorious in this respect. Addition of 20 million colibacteria to one ml. semen causes the motility to decrease to 10 % after one hour and to stop completely after 3 hours (VASTERLING 1960).

In practice, however, it is difficult to obtain semen in a sterile condition and to perform the test under aseptic conditions.

For this reason, before setting up the test, one drop of an antibiotic solution containing 0.5 mg. neomycin and 500 U. penicillin was added per cc. ejaculate. This quantity is entirely sufficient to render the semen bacteriostatic and has no influence on the motility of the spermatozoa. The quantities indicated by JOËL (1958): 60.000 U. penicillin or 10-20 mg. chloramphenicol per cc. semen, are unnecessary. In my experiments these latter concentrations, which from the point of view of bacteriostasis must be considered excessive, actually appeared to have an unfavourable influence on the motility of spermatozoa.

The advantage of using neomycin and penicillin is that these materials are soluble in water. The solution must be stored in the refrigerator and is under these conditions stable for 5 days. Investigations as to the influence of the addition of the penicillin-neomycin solution on the growth of bacteria and on the motility of the spermatozoa will be published (KREMER, publication in preparation).

In filling the S P M, the tip of the pipette must be placed on the bottom of the reservoir, to allow the air to escape. This is important since an air bubble in the semen adversely influences the motility of the spermatozoa.

Because of surface tension, the semen will not flow out of the reservoir when the S P M is laid flat. Even when the opening of the reservoir points downwards, the semen remains in place.

The cervical mucus or blood serum is sucked up into a Pasteur pipette, the capillary of which has an external diameter of 0.9-1 mm.

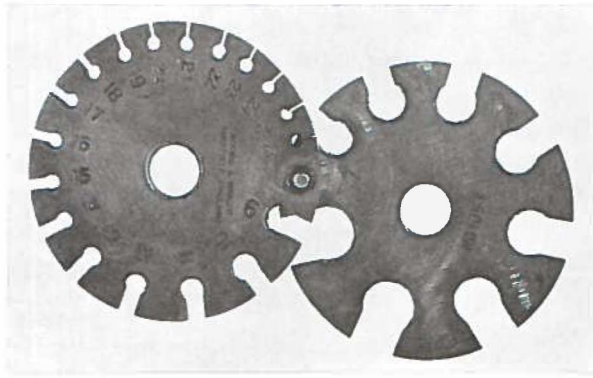

Fig. 12. Wire gauge, used for measuring the diameter of glass capillaries.

The diameter can be measured with a so-called wire gauge (fig. 12), an instrument intended for determining the thickness of wire.

The capillary of the Pasteur pipette is then broken off at a distance of 6 cm. from the open end. The glass capillary thus obtained, filled with cervical mucus or serum, is fitted at one end with a small lump of modelling wax the size of a grain of wheat. By carefully pressing this modelling wax into the lumen of the glass capillary for a distance of 1-2 mm., the contents of the capillary are displaced and a drop protrudes from the other end. The drop stays in place by adhesive and cohesive forces (fig. 13).

The glass capillary is then placed in the semen, avoiding contact of the mucus or serum drop with the glass of the reservoir. The bottom of the capillary reaches to the first gradation of the apparatus. Using the modelling wax, the capillary is then fastened to the glass slide (fig. 14).

The transverse glass rod prevents the glass capillary from making contact with the slide. In this way, formation of a capillary crevice between the glass capillary and slide is prevented. The semen from the reservoir would rise in such a capillary crevice and this is undesirable.

The S P M filled in this way is placed in a moist Petri dish which is then placed in an incubator at 37° C. After 30 minutes, the S P M is taken from the Petri dish and laid on the viewing stage of a microscope. With the low power dry system (ocular no. 8 and objective



Fig. 13 Glass capillary, filled with cervical mucus. By pressing the plug of modelling wax a short way into the glass capillary, some cervical mucus protrudes from the other end.

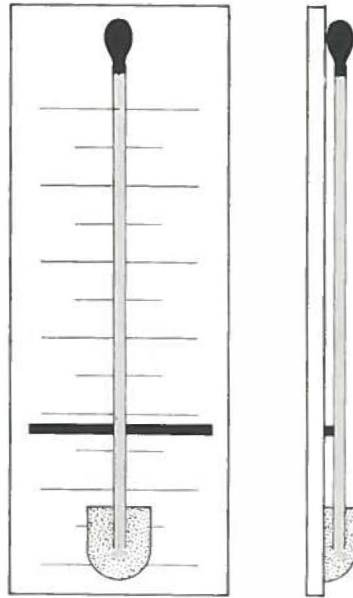

Fig. 14 Sperm penetration meter (S P M). The semen is in the reservoir and the cervical mucus (or another medium) in the glass capillary. Left: front view. Right: side view.

no. 10), the capillary is studied, beginning at the semen reservoir and proceeding thence longitudinally, for the presence of spermatozoa. They are easy to recognize as such, immediately under the glass wall of the capillary nearest to the object lens (fig. 15). If one focusses on the deeper layers, distortion occurs as a result of the curvation of the glass wall of the capillary (fig. 16). Non-motile spermatozoa in these layers are no longer recognizable as such.

The distance covered by the most advanced spermatozoon, calculated from the beginning of the glass capillary, is now noted. The calibrations on the slide make this determination simple. The value found is recorded and the sperm penetration meter once again incubated at 37° C. One and a half hours later, i.e. two hours after commencing the test, this determination is carried out again. The number of spermatozoa per visual field at distances of 1 cm., 3 cm. and 5 cm. is also determined. During this, the number of morpho-

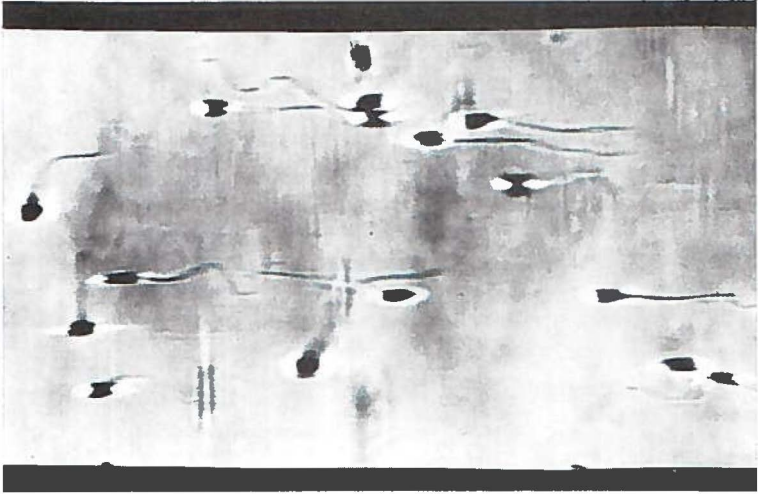

Fig. 15. Microphoto (instant exposure, magnification x 500) of spermatozoa which have penetrated into the glass capillary of the S P M filled with cervical mucus. The majority of the spermatozoa are moving forward parallel to the glass wall of the capillary.

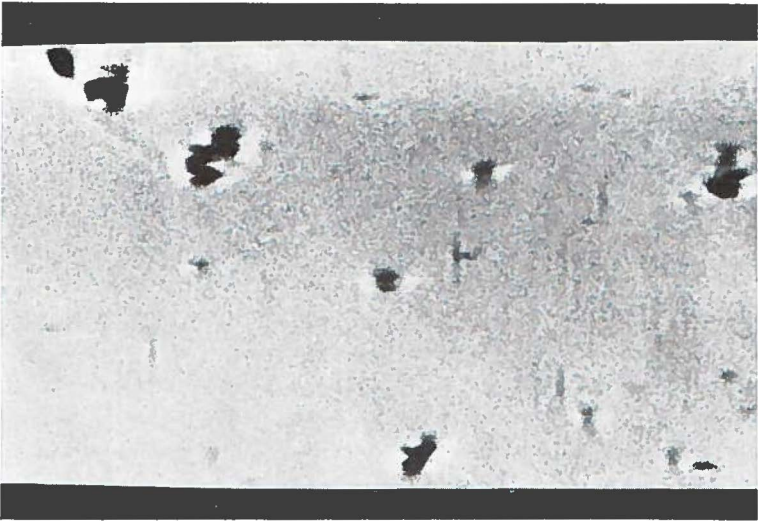

Fig. 16. Microphoto (instant exposure, magnification x 500) of spermatozoa which have penetrated into the glass capillary of the S P M filled with cervical mucus. By focussing on a deeper layer, considerable distortion of the spermatozoa occurs.

logically clearly-recognizable spermatozoa in each visual field is counted or (when the density is high) estimated. The motility of the spermatozoa at the above mentioned points in the capillary is determined by estimation. The number of spermatozoa per visual field is recorded as follows:

0— 5 spermatozoa per visual field				
5— 10	”	”	”	”
10— 20	”	”	”	”
20— 50	”	”	”	”
50—100	”	”	”	”
100—200	”	”	”	”
more than 200	”	”	”	”

To describe the qualitative motility, the same number gradation is used as for semen evaluation (described on page 29).

Incubation is then continued at 37° C; at 8 hours, 24 hours, 48 hours and 72 hours after the beginning of the test, the determinations listed above are repeated. Each determination requires no more than 1-2 minutes.

With this simple and rapid method one has three different types of data available, viz. the *depth of penetration* (linear progression), *penetration density* (quantitative penetration) and the *duration of motility* (longevity) of the spermatozoa in the medium in question. It is further possible, with the help of the method described above, to obtain a fourth type of data, namely the *average speed* at which the spermatozoa progress into the medium in question. This value cannot be directly derived from the linear progression because it is not only determined by the speed of progression of the spermatozoa but also by the time between the commencement of the test and the instant at which the spermatozoa succeed in penetrating from the semen into the medium. When the viscosity of the material used is low, this interval is short; when the viscosity is high, it is much longer. Besides this, there are media in which the spermatozoa progress more or less in a straight line and others in which the spermatozoa continually change direction during their progression.

When normal cervical mucus is used, obtained during the ovulation period, it is possible to determine the spermatozoal speed

quite accurately in this medium. For this, one utilizes the fact that the majority of the spermatozoa advances in this medium in a straight line parallel to the wall of the glass capillary (fig. 15). This can be explained since during aspiration of the cervical mucus into the glass capillary, the long filaments of macromolecules, which frame the basic structure of this material, are stretched longitudinally and come to lie more or less parallel to the wall of the glass capillary.

Between the molecular filaments, "channels" of an aqueous, isotonic solution containing electrolytes and glucose exist. These "water channels" also run parallel to the wall of the glass capillary and are utilized by the spermatozoa to move forward (GIBBONS and GLOVER 1960, TAMPION and GIBBONS 1962, SOBRERO 1963).

The long macromolecular filaments in the cervical mucus, the existence of which had been postulated on the basis of very reasonable hypotheses (ODEBLAD 1958, GIBBONS 1959, GIBBONS and GLOVER 1959), were rendered visible for the first time in electronmicroscopic studies performed in 1967. The filaments, 25 Å in diameter, proved to be composed of subunits which were probably globular (fig. 17). The pronase experiment (treatment with the proteolytic enzyme pronase) showed that the backbone of these filaments consisted of protein. Hyaluronidase digestion showed no morphological differences with the Kleinschmidt-technique (VAN BRUGGEN and KREMER; publication in course of preparation).

To determine the speed of the spermatozoa in the cervical mucus use is made of a stopwatch. When a particular spermatozoon passes a calibration, the stopwatch is started. The spermatozoon is then "followed" to the next calibration. By dividing the distance covered by the time interval measured, the speed of the spermatozoon can be calculated with quite a high degree of accuracy.

By calculating the speed of a large number of spermatozoa in this way, the average speed of spermatozoal migration can be determined fairly accurately. This is indeed a procedure requiring some time and is thus unsuitable for a routine investigation. For this reason, a more rapid method is used which is however somewhat less accurate. This could be called the "dispatch rider method". In this method of measuring speed, the observation of a particular spermatozoon which has been followed for a time, is transferred to another spermatozoon which is either just passing or being passed.

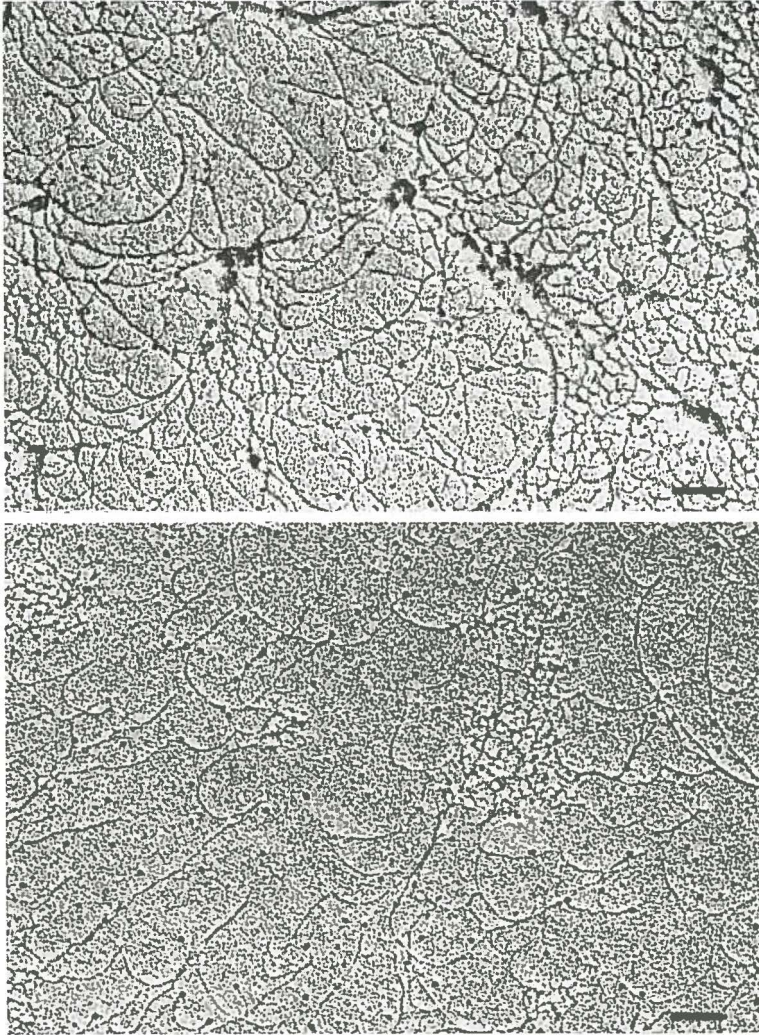

Fig. 17. **Electron microscopic picture of human cervical mucus.** (Scale line = 0.1μ). 108 mg. unpurified human cervical mucus, taken during the ovulatory phase, was diluted with 30 ml. of a solution containing 480 mg. LiOH, 1000 mg. citric acid and 10 % ethanol, and brought to pH 6.0 with dilute citric acid. After standing about 24 hours at 35° C, a homogeneous solution was obtained. Then a mixture of 3 droplets of solution and 1 droplet 0.08 % cytochrome-c was spread on 0.1 M ammonium acetate. Carbon filmed grids were floated on the protein area for about 30 seconds. After blotting with filter paper and air drying, they were shadowed for about 10 seconds under rotation (speed 3000 rev/min.) with 7 mg. platinum at a distance of 5 cm. and an angle of 8° .

If this "changing" of spermatozoa is repeated many times, a very close approximation of the average speed of the spermatozoa in the cervical mucus can be obtained.

Using normal cervical mucus from the ovulation period and normal semen, I found an average speed of spermatozoa in cervical mucus of 1.8 mm. per minute (see page 72).

When serum is used as medium, determination of the average speed by the above method is impossible, because then the spermatozoa do not travel forward in a straight line. It is possible to correlate the distance covered by the spermatozoa in the column of liquid with the time required and from this, to draw a conclusion as to the speed at which the spermatozoa observed can move forward in body fluids in which the straight "water channels" of cervical mucus are absent.

chapter 3

results of the investigations with the SPM test

A. Preliminary investigations

Before introducing the S P M test as a routine part of the sterility examination, some investigations were made into exogenous factors which could influence the result of this test, into the standardization of the penetration medium, and into the reproducibility of the test.

The results of these investigations showed that the S P M test appears to be a useful addition to the sterility examination.

These preliminary investigations were the following:

- I Investigation into the possibility of passive transfer of non-motile particles from the semen reservoir into the fluid-filled glass capillary of the S P M.
 - II Investigation into the effect of temperature on the result of the S P M test.
 - III Investigation comparing the results of the S P M test with the following as penetration medium: an isotonic glucose-saline solution, a colloidal plasma substitute, pasteurized human plasma protein or blood serum.
 - IV Investigation into the effect of storage of human blood serum under deepfrozen conditions on the results of the S P M test, when this deep frozen blood serum was used after thawing as penetration medium.
 - V Investigation into the reproducibility of the S P M test.
- I. *Investigation into the possibility of passive transfer of non-motile particles from the semen reservoir into the fluid-filled glass capillary of the S P M.*

- a. *Investigation into the possibility of passive transfer of carbon particles from seminal plasma into cervical mucus.*

The reservoir of the S P M was filled with carbon particles the size of spermatozoa, suspended in seminal plasma.

The glass capillary was filled with cervical mucus, the physico-chemical properties of which had been shown to be suitable for penetration and migration of motile spermatozoa.

The S P M was then placed in a moist Petri dish and incubated at 37° C. After 30 minutes and after 8 hours a microscopical check was carried out. No transfer of carbon particles into the cervical mucus was observed. The test was repeated five more times with normal ovulation cervical mucus from 5 different women. In no case were carbon particles observed in the capillary.

- b. *Investigation into the possibility of passive transfer of dead spermatozoa from semen plasma into cervical mucus.*

The left-hand reservoir of an S P M with three semen reservoirs was filled with semen having a spermatozoal density of 196 million per cc. The quantitative motility of the spermatozoa at the time when the test was set up was 70 0/0; the qualitative motility grade 4. The right-hand reservoir was filled with the same semen, which had been incubated for one hour at 60° C in order to kill the spermatozoa. After a glass capillary filled with normal ovulation cervical mucus had been inserted in both semen reservoirs, the S P M was placed in a moist Petri dish in an incubating oven at a temperature of 37° C. Checks were carried out after 30 minutes, 2 hours and 8 hours. After 60 minutes it was observed that 50-100 actively motile spermatozoa per L.P.F. ($\times 80$) were present at a distance of 6 cm. from the beginning of the capillary which was situated in the semen with motile spermatozoa. The capillary inserted into the semen containing only dead spermatozoa, contained no spermatozoa after 30 minutes, after 2 hours or after 8 hours.

The experiment was repeated 10 times, each time with a different semen and different cervical mucus. In not a single case was transfer of dead spermatozoa into the cervical mucus ob-

served. No special measures were taken to avoid jerky movements or to maintain the horizontal position of the S P M.

c. *Transfer of dead spermatozoa from semen plasma into blood serum.*

The reservoirs of 6 different S P M's were filled with semen, whose spermatozoa had been killed by placing the semen for one hour in an oven at 60° C.

The glass capillaries of these six S P M's were filled with blood serum AB, Rh +. It had been shown that motile spermatozoa penetrated and migrated well into this blood serum type. The six S P M's were then laid in a moist Petri dish which was placed in an oven at a temperature of 37° C. After 30 minutes the first check was performed. Spermatozoa were not present in the glass capillary of any of the six S P M's. After 2 hours, however, spermatozoa were seen in the glass capillary of two of the six S P M's at a distance of 1/2 cm. and 3/4 cm. from the beginning of the tube.

The possibility of *mixing* of semen and serum at the surface of contact of the two liquids was considered; thus the experiment was repeated in three different ways.

In the first instance, care was taken to ensure that the S P M remained horizontal, and jerky movements in transfer were avoided. Under these conditions it was found that after 2 hours and 8 hours, no transfer of spermatozoa had taken place into the blood serum in the capillary. In the second instance, the horizontal position of the S P M was alternated several times from the vertical position. In the third instance, the S P M's were kept horizontal but several rapid shaking movements were performed. Both in the second and the third experiment, transfer of spermatozoa into the glass capillary was seen to have taken place so that even at a distance of 5 cm. from the beginning of the tube spermatozoa were visible.

The conclusion which can be drawn from the above experiment is that, when blood serum is used as medium in the S P M, reliable results can only be obtained when care is taken that the S P M always *remains in the horizontal position* and that *jerky movements are avoided*.

II. *Investigation into the effect of temperature on the result of the S P M test*

The purpose of the investigation was to check whether, and to what extent, the results of the S P M test were influenced by temperature. To do this, 8 semen samples from 8 different men were subjected to an S P M test at room temperature, at 37° C. and at 40° C. Blood serum (AB Rh +) was used as penetration medium.

The results of this investigation are shown in Table 1. From this table it can be seen that at 37° C. and at 40° C. penetration and migration of spermatozoa into blood serum takes place more quickly than at room temperature, while the duration of motility is longer at room temperature. In all 8 cases at a temperature of 40° C. the duration of motility is at least 24 hours less than at a temperature of 37° C.

The same influence on spermatozoal penetration, migration and longevity was observed when cervical mucus from the ovulation period was used instead of blood serum.

For the results of the S P M test, and more specifically as far as duration of motility of the spermatozoa is concerned, it is therefore important that the incubator in which the S P M is placed has a good thermostat.

III. *Investigation comparing the results of the S P M test when different fluids were used as penetration medium*

The purpose of this investigation was to find a fluid medium for the S P M test, which would give test results as good as those obtained with fresh blood serum, and which would be more easily obtainable and more stable. The results of this investigation are shown in Table 2. This table shows the average results of 5 series of experiments in which use was made of a different semen each time. The fertility of the 5 semen samples varied from *poor* to *good*. From Table 2 it can be seen that as far as the depth of penetration, the penetration density and the duration of motility of the spermatozoa in the penetration medium in question were concerned, the results were better when fresh blood serum was used than with any one of the other three fluids.

IV. *Investigation into the effect of storage of human blood serum under deep-frozen conditions on the results of the S P M test, when this deep-frozen blood serum was used after thawing as penetration medium*

The object of this investigation was to check whether human blood serum which had been stored for a prolonged period under deep-frozen conditions would, after thawing, give the same results when used as penetration medium in the S P M test, as would fresh blood serum.

If this were indeed the case, in this way a depot of blood serum could be available for performance of the S P M test.

For this investigation, the results of 4 S P M tests were compared. In each case the same semen was used and the blood serum in the four glass capillaries had been taken from the same donor under the same conditions (in the morning before a meal) 2 months, 1 month, 1 week and 1 hour before setting up the test. The first three serum samples were deep-frozen immediately after withdrawal.

The penetration depth after 30 minutes, the penetration density after 2 hours at a distance of 5 cm., the qualitative motility of the spermatozoa at a distance of 5 cm. after 2 hours and the duration of motility showed only minor differences in the four tests.

The experiment was repeated once more, using serum and semen from another source. Once again nearly the same results were obtained. The results with the fresh serum were sometimes slightly better, sometimes slightly poorer than with the deep-frozen serum.

The conclusion is that deep-frozen serum can be stored in a depot for use as penetration medium for the S P M test. The advantage of deep-frozen serum over fresh serum is primarily that the same serum can always be used over a period of at least 2 months; whereas fresh serum cannot always come from the same donor, and thus would lead to a greater variation in the results of the S P M test. Also, in practice, it is not feasible to obtain sufficient donors with blood group AB Rh +. From immunological considerations, however, this blood group is to be preferred.

In our laboratory use is always made of deep-frozen serum of blood group AB Rh + for the S P M test, when this test is used as part of the semen investigations. The serum is stored in a number of

small test tubes each of which contains approximately 0.5 cc. serum. With each tube approximately 20-30 S P M tests can be performed. The advantage of this is that not all the available serum has to be thawed out whenever an S P M test is to be performed. Serum stored in this way is stable for a long period.

V. *Investigation into the reproducibility of the S P M test*

a. *The reproducibility with cervical mucus as penetration medium.*

For this experiment 10 S P M tests were performed simultaneously with the same semen and the same cervical mucus. The spermatozoal density in the semen was 62.10^6 ; the quantitative motility of the spermatozoa was 60% and the qualitative motility grade 3 +. The cervical mucus fulfilled the criteria for normal cervical mucus from the ovulatory phase. (see page 39). All tests were carried out at 37° C.

The reproducibility of the following determinations was investigated:

1. The penetration depth after 10 minutes and after 30 minutes.
2. The spermatozoal density after 2 hours at 5 cm.
3. The qualitative motility of the spermatozoa after 2 hours at 5 cm.
4. The duration of motility of the spermatozoa.

ad 1. The penetration depth after 10 minutes varied in the 10 tests from 2.3 to 2.8 cm. After 30 minutes in all capillaries, the end of the capillary had been reached (6 cm.).

ad 2. The spermatozoal density after 2 hours, at a distance of 5 cm. from the beginning of the capillary in all tests was 50-100 spermatozoa per L.P.F. ($\times 80$). It appeared that the reproducibility of this determination was strongly dependent on the size of the "bead" of mucus which protruded from the glass capillary to form a surface of contact with the semen in the reservoir. When the volume of these "beads" was very different, it was then seen that the spermatozoal density varied after a particular time at

a particular place in the different glass capillaries. The highest spermatozoal density was obtained in the capillaries where the intra-seminal mucus "beads" had the greatest volume.

- ad 3. The qualitative motility of the spermatozoa, present after two hours at a distance of 5 cm. from the beginning of the glass capillary, was classified as grade 3 in 8 tests and as grade 3- in 2 tests.
- ad 4. The duration of motility of the spermatozoa in the 10 different tests varied from 40-48 hours. The qualitative motility in all capillaries decreased to an almost equal degree with the passage of time.

In contrast to the determination mentioned under 2, the determinations mentioned under 1, 3 and 4 were found to be reproducible even where the intraseminal mucus beads showed marked volume variations.

b. *The reproducibility of the S P M test with blood serum as penetration medium*

For this investigation, 10 S P M tests were also performed simultaneously under the same conditions using the same serum and the same semen. The temperature in all cases was 37° C.

The depth of penetration after 10 minutes varied in all tests from 1.2 to 1.5 cm., after 30 minutes from 3.5 to 4 cm.

The penetration density at 5 cm. after 2 hours in all cases was 10-25 spermatozoa per visual field.

Since in the S P M test with serum as penetration medium the surface of contact between semen and serum always corresponds with the cross-sectional area of the glass capillary, reproducibility of the penetration density of the spermatozoa is more easily possible than when using cervical mucus as penetration medium. The qualitative motility of the spermatozoa after 2 hours, at a distance of 5 cm. from the beginning of the glass capillary, was classified in all cases as grade 3. The duration of motility of the spermatozoa varied in the 10 different tests from 72 to 76 hours.

For the reproducibility of the tests described under a. and b. use was made of semen with a spermatozoal density of 62 million per cc., with a motility of 60% gr. 3 +. With different specimens having spermatozoal density of 22 million/cc., 8 million/cc., and less than 1 million/cc., and the motility given respectively as 30% gr. 2+, 20% gr. 1+ and less than 5% gr. 1, in the tests mentioned above, the same degree of reproducibility was obtained as described for tests using normal fertile semen.

From these experiments it can be concluded that the S P M test shows a sufficiently high degree of reproducibility for use in clinical investigation. For reproducibility, the test must be accurately performed, in order to eliminate all exogenous factors which can influence the result.

B. Results of the investigations with the S P M test as a routine part of the sterility examination

I. Procedure for performance of the investigations

As a rule in the course of the fertility examination, a single S P M test was performed on each couple. For that purpose the wife visited the sterility clinic on one of the three days preceding the probable ovulation day. She came before 9 a.m., bringing with her an ejaculate from her husband, obtained less than 2 hours previously, after a period of abstention of 3 to 5 days.

The cervical mucus necessary for the test was obtained as described on page 32. Ten cc. of blood was also withdrawn from the wife by venepuncture, and collected in a sterile test tube. This blood was taken to the laboratory together with the cervical mucus and the ejaculate. The cervical mucus was placed on a clean microscopic slide by the clinic doctor immediately after collection. This slide was immediately laid in a moist Petri dish previously prepared. The name of the patient was written on the Petri dish with a grease pencil while a request form for performance of the penetration test was also filled out and added. The request form for the semen investigation had already been completed at home by the husband and attached to the bottle with the ejaculate.

In the laboratory, the procedure for the investigation was as follows:

Using an S P M with three reservoirs (the maximum number for a normal sized slide), the S P M test was performed in the following way (see also fig. 18):

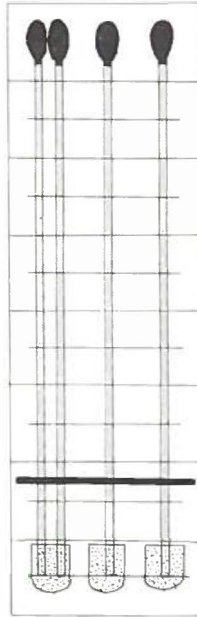

Fig. 18. S P M with three semen reservoirs.

1. The three reservoirs were filled with semen from the husband.
2. In the right-hand reservoir, a capillary was placed filled with cervical mucus from the wife. This capillary was closed with modelling wax of the same colour as the form concerned (yellow).
3. In the central reservoir, a capillary filled with normal cervical mucus from the ovulation phase of another woman was placed. To have this heterologous cervical mucus always available, a depot was set up. The material for this depot was obtained from the cervical mucus of women enrolled at the sterility clinic, whose husbands had azoospermia.

Since during the fertility investigation, two Sims-Huhner tests were performed as routine on every woman, even when the semen of her husband contained no spermatozoa, sufficient normal ovulation cervical mucus could normally be held in reserve to permit a cross test to be performed alongside each homologous S P M test.

The depot cervical mucus was stored in glass capillaries of 6 cm. length and external diameter of 0.9-1 mm. After being filled, these capillaries were closed at both ends with a small lump of modelling wax, the colour of which (green) corresponded with the colour of the form for performance of the cross test. These capillaries were then placed in a special holder (see fig. 19),

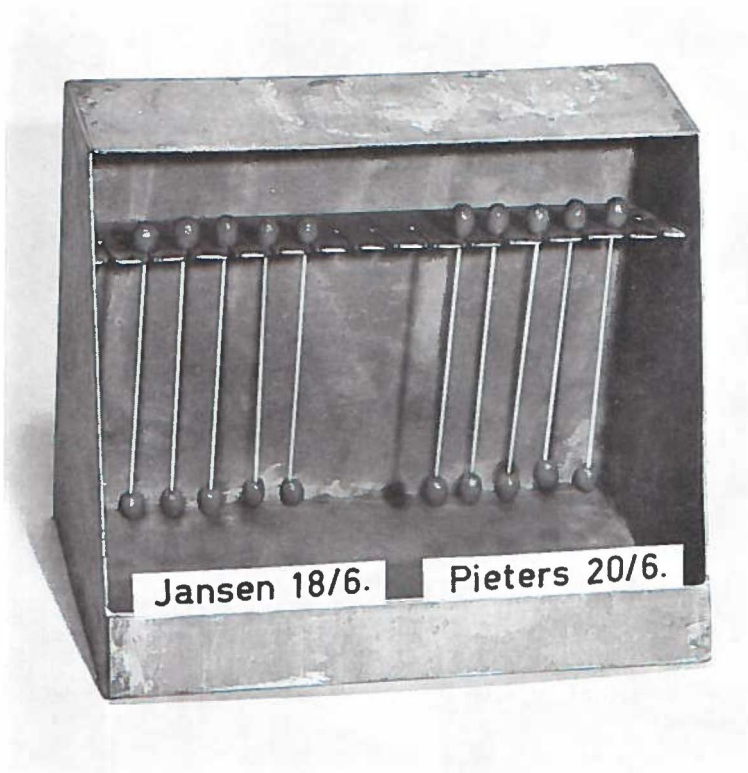

Fig. 19. Holder for capillary tubes, filled with cervical mucus. The holder is stored in the refrigerator at a temperature of 4° C.

and stored in the refrigerator at a temperature of 4° C. for not longer than one week. Deep freezing of the material was not feasible since, on thawing, small air bubbles formed in the mucus.

4. In the left-hand reservoir, two capillaries with blood serum were placed. One capillary contained blood serum AB Rh + and was

fitted with a small piece of blue modelling wax (the colour of the semen form). The other contained blood serum of the wife and was fitted with a small piece of white modelling wax (the colour of the form on which the results of this test were reported.)

The S P M set up in this way was placed in a moist Petri dish in the incubator. After 30 minutes, 2 hours, 8 hours, 24 hours, 48 hours and 72 hours a microscopic check was made. In some cases, checking continued after 72 hours.

The determinations, carried out at the times mentioned above, were as follows:

- a. Measurement of the depth of penetration, 30 minutes and 2 hours after commencement of the test. For this, the number of centimetres (to an accuracy of 0.5 cm.) separating the furthest-advanced spermatozoon from the beginning of the capillary was determined.
- b. Counting the number of motile spermatozoa, with tails clearly visible, at a distance of 1 cm., 3 cm. and 5 cm. from the beginning of the capillary. This determination took place 2 hours after commencement of the test. The degree of motility of the spermatozoa was also determined.
- c. In a number of cases, 30 minutes after commencement of the test, the speed of progression of the spermatozoa was determined.
- d. 8 Hours, 24 hours, 48 hours and 72 hours after commencement of the test, it was ascertained if motile spermatozoa were still present in the capillary. Their position in the capillary and their quality of motility were noted. In some cases, checking was continued even longer.

The results of the above determinations give an idea of the speed and density with which the husband's spermatozoa can migrate through a column of the wife's cervical mucus and through a column of the wife's blood serum and also of the time during which the husband's spermatozoa remain motile at a temperature of 37° C. in these materials. It seems probable that these data are related to the chance of conception for a couple, because in this *in vitro* test the conditions in the genital tract of the wife are fairly accurately imitated. The results of the S P M test can therefore be incorporated into the final fertility assessment of the couple in question.

On the basis of the data obtained during a period of four years (1963-1967) with the S P M test using *cervical mucus* as penetration medium, results obtained have been classified as follows:

- excellent penetration depth after 30 minutes at least 6 cm.
and
penetration density after 2 hours at 5 cm.:
> 50 spermatozoa per L P F (\times 80)
and
qualitative motility after 2 hours at 5 cm.: \geq grade 3
and
duration of motility at least 48 hours.
- good penetration depth after 30 minutes at least 5 cm.
and
penetration density after 2 hours at 5 cm.:
> 10 spermatozoa per L P F
and
qualitative motility after 2 hours at 5 cm.: \geq grade 2
and
duration of motility at least 24 hours.
- fair penetration depth after 2 hours at least 5 cm.
and
penetration density after 2 hours at 5 cm.:
 \geq 1 spermatozoa per L P F.
and
qualitative motility after 2 hours at 5 cm.: \geq grade 1
and
duration of motility at least 8 hours.
- poor penetration depth after 2 hours: < 5 cm., > 3 cm.;
in addition, duration of motility at least 2 hours
or
qualitative motility after 2 hours at 5 cm.: less than
grade 1; in addition, duration of motility at least
2 hours
or
duration of motility: < 8 hours, > 2 hours;
in addition, depth of penetration > 3 cm. after
2 hours.
- bad penetration depth after 2 hours: \leq 3 cm.
or

duration of motility: < 2 hours (i.e. 2 hours after commencement of the test, nowhere in the capillary are motile spermatozoa still to be found).

neg. no penetration.

Using *blood serum* as penetration medium, the classification was as follows:

- excellent penetration depth after 30 minutes at least 6 cm.
and
penetration density after 2 hours at 5 cm.:
 > 50 spermatozoa per L P F ($\times 80$)
and
qualitative motility after 2 hours at 5 cm.: \geq grade 4
and
duration of motility at least 72 hours.
- good penetration depth after 30 minutes at least 4 cm.
and
penetration density after 2 hours at 5 cm.:
 > 10 spermatozoa per L P F
and
qualitative motility after 2 hours at 5 cm.: \geq grade 3
and
duration of motility at least 48 hours.
- fair penetration depth after 2 hours at least 5 cm.
and
penetration density after 2 hours at 5 cm.:
 ≥ 1 spermatozoa per L P F
and
qualitative motility after 2 hours at 5 cm.: \geq grade 2
and
duration of motility at least 24 hours.
- poor penetration depth after 2 hours: < 5 cm., > 3 cm.;
in addition, duration of motility at least 8 hours
or
qualitative motility after 2 hours at 5 cm.: $<$ grade 2;
in addition, duration of motility at least 8 hours
or
duration of motility: < 24 hours, ≥ 8 hours;
in addition, penetration depth > 3 cm. after 2 hours.

bad penetration depth after 2 hours: ≤ 3 cm.
or
duration of motility < 8 hours.
neg. no penetration.

The difference between the classification with cervical mucus as penetration medium and the classification with blood serum as penetration medium is related to the difference in physico-chemical structure of the two fluids. Due to the presence of water channels (see page 47) in cervical mucus, the linear progression of spermatozoa in this material is somewhat greater than in blood serum. Therefore, for the penetration depth after $\frac{1}{2}$ hour, higher demands are made of cervical mucus than of blood serum. However, blood serum is a more favourable medium than cervical mucus for qualitative motility after 2 hours and duration of motility of the spermatozoa. Therefore, for both of these properties, higher demands were made of blood serum than of cervical mucus.

II. Results of the investigations

1. The results with normal ovulation cervical mucus as penetration medium and semen of different quality

In Table 3 the results are shown of 135 homologous SPM tests, carried out on 135 different couples, in which normal cervical mucus from the mid-cycle period of the wife was used. By normal cervical mucus in this connection is understood cervical mucus the physico-chemical properties of which satisfy the criteria given on page 39. The quality of the semen used varied from *bad* to *good*, according to the classification shown on page 31. In all 135 cases the husband in question stated on the enclosed semen form that the semen was obtained by an ejaculation brought about manually.

Tables 3a, 3b, 3c and 3d are derived from the main Table 3, and show respectively the relationship between the density, the quantitative motility, the qualitative motility and the morphology of the spermatozoa on the one hand and the result of the SPM test on the other.

In Table 3e the properties of the semen from Table 3a, 3b, 3c, and 3d are combined to give an assessment of fertility of the semen.

The relationship is shown between this fertility assessment and the result of the S P M test.

From Table 3a it can be seen that, in 10 cases with a spermatozoal density of less than 5 million per cc., the S P M test at best could achieve the classification *bad*. Of the 30 ejaculates with a spermatozoal density of 5 to 20 million per cc., there were only 7 (23 %) which could be classified as *fair*; 77 % were *negative, bad* or *poor*. When the spermatozoal density had risen to a value of 20-60 million per cc. (37 cases), the result of the S P M test became obviously better; 28 of these cases (76 %) could be classified as *fair, good* or *excellent*. With a spermatozoal density of 60 million or more per cc. (58 cases), there were 49 (84 %) where the S P M test was classified as *fair, good* or *excellent*. The percentage of tests regarded as *good* or *excellent* in this group was 39 (against 19 % in the previous group).

In the 40 cases with a spermatozoal density of less than 20 million per cc., the classification *good* or *excellent* was not attained. Apparently a spermatozoal density of at least 20 million spermatozoa per cc. is necessary for such a result.

To calculate χ^2 , rows 1,2 and 3, columns negative, bad and poor and columns good and excellent were combined.

$$\chi^2 = 55.585 \qquad df = 4 \qquad P < 0.0005$$

From Table 3b it can be seen that, of the 21 semen specimens where less than 5 % of the spermatozoa were motile at commencement of the test, the S P M test in 90 % of these cases was classified as *negative, bad* or *poor*, and in 10 % as *fair*. In 39 cases with a quantitative spermatozoal motility in the semen of 5-40 %, 16 S P M tests (41 %) produced results which could be regarded as *fair* or *good*. In the following motility group in which the quantitative motility was 40-60 % (37 cases), the percentage of S P M tests with the classification *fair, good* or *excellent* was 89. The results in the 38 cases, where the quantitative motility of the spermatozoa in the semen was 60 % or more, were no better than in the previous group; of these 38 cases, there were 33 (87 %) where the S P M test was shown as *fair, good* or *excellent*.

There is therefore an obvious improvement in the result of the

S P M test as the quantitative motility of the spermatozoa in the semen increases. This improvement does not progress further after the quantitative motility has become 60 %.

To calculate χ^2 , rows 1 and 2, rows 4 and 5, columns negative, bad and poor and columns good and excellent were combined.

$$\chi^2 = 58.124 \quad df = 4 \quad P < 0.0005$$

From Table 3c, which refers to the relationship between the qualitative motility of the spermatozoa in the semen and the result of the S P M test, it is seen that the qualitative spermatozoal motility has an obvious effect on the result of the test. The percentage of S P M tests with the classification *fair*, *good* or *excellent* from group 1-5 was respectively 0, 22, 42, 85 and 100 %. This strong correlation was also to be expected on theoretical grounds because the qualitative motility of the spermatozoa must have a pronounced influence on the degree of penetration into and migration in the cervical mucus. Besides this, good qualitative motility of the spermatozoa is normally accompanied by good longevity, resulting in prolonged motility of the spermatozoa in the cervical mucus.

To calculate χ^2 , rows 1 and 2, rows 4 and 5, columns negative, bad and poor and columns good and excellent were combined.

$$\chi^2 = 50.337 \quad df = 4 \quad P < 0.0005$$

Table 3d deals with the relationship between the morphology of the spermatozoa and the result of the S P M test. The improvement in the result of the S P M test from group 1 to group 5 is less obvious in this Table than in Tables 3a, 3b and 3c. Group 1 in Table 3d gives even better results of the S P M test than group 2. This is probably attributable to the fact that generally, *but not always*, a positive relationship exists between the density and the motility of the spermatozoa on the one hand and the percentage of normal head forms on the other. In some cases a bad morphology can accompany a good density and good motility of the spermatozoa. Case no. 105 in Table 3 is an extreme example of this; the whole

spermatozoal population in this instance had abnormal head forms (micro-strongylospermia, see fig. 20).

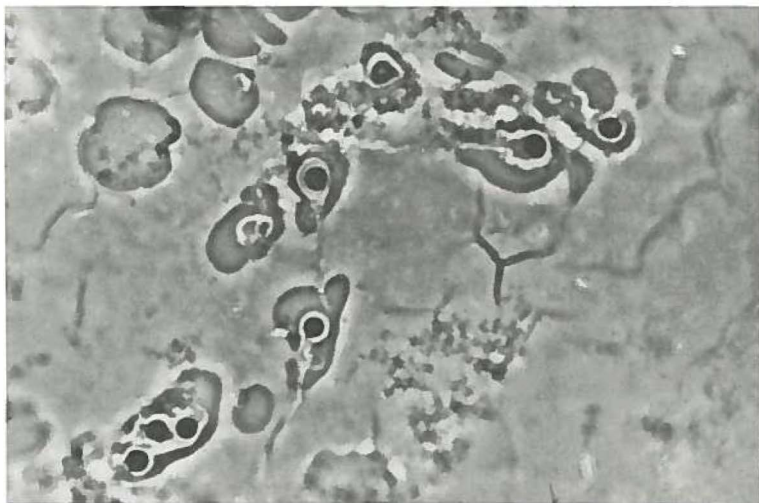

Fig. 20. Phase contrast photograph of a dry semen smear in a case of micro-strongylospermia. All the spermatozoa in this semen had a little, round head; sperm density and motility were normal.

However, the result of the S P M test is significantly better with ejaculates where more than 60 % of the spermatozoa had a normal headform than with ejaculates having less than 60 % normal headforms.

To calculate χ^2 , rows 1, 2 and 3, rows 4 and 5, columns negative, bad and poor and columns good and excellent were combined.

$$\chi^2 = 15.105 \quad df = 2 \quad 0.0005 < P < 0.001$$

From Table 3e it can be seen that a very close relationship exists between the fertility assessment of the semen and the result of the S P M test.

Of the 12 semen specimens which were classified as *bad*, there was only one which attained the classification *fair* in the S P M test; the other 11 were *negative*, *bad* or *poor*. Of the 43 semen specimens with a fertility assessment of *poor*, the S P M tests in 13 cases (30 %)

were *fair* or *good*. Of the 29 men whose semen was assessed as *passable*, 26 (90 %) of them had S P M tests with ratings of *fair*, *good* or *excellent*. In the 51 cases from group 5, where the quality of the semen was shown as *good*, the S P M test was 44 times (86 %) shown to be *fair*, *good* or *excellent*. In this group the number of tests with *good* or *excellent* results was 22 (43 %). The results of the S P M test in this last group thus obviously improved qualitatively compared to the previous group (group 4) where 17 % of the tests were *good* or *excellent*.

To calculate χ^2 , rows 1, 2 and 3, columns negative, bad and poor and columns good and excellent were combined.

$$\chi^2 = 63.893 \qquad df = 4 \qquad P < 0.0005$$

From Table 3e it can be seen further that in 10 of the 80 cases in which the semen had been classified as *passable* or *good* (groups 4 and 5), the S P M test was *negative*, *bad* or *poor*. This involved cases no. 44, 65, 81, 83, 89, 100, 103, 104, 123 and 130 of Table 3.

The results of the sterility investigation of the couples in question were checked in an attempt to find an explanation for this discrepancy. The check showed that in cases 44, 65, 81, 103 and 130 the result of the heterologous S P M test (cross test) was *good* or *excellent*. In this cross test use was made of semen from the husband and normal cervical mucus from the ovulation phase of another woman. The cervical mucus of the wife was thus apparently "hostile" to the spermatozoa of her husband, so that penetration, migration and survival of these spermatozoa in the wife's cervical mucus were unfavourably influenced. In all these cases, the spermatozoa which, two hours after commencement of the test, had penetrated most deeply into the cervical mucus of the wife, gave a qualitative motility of the spermatozoa of 1 or less than 1.

The reason for this cervical hostility is not immediately clear. It is possible that in the otherwise normal cervical mucus of these women, a substance was present which exerted an immobilizing effect on the spermatozoa of their husbands. This hypothesis is supported by the fact that when the Sims-Huhner test was performed on these 5 couples (done at least twice on each couple) in only one instance was the result *fair* and in the other cases it was always *bad*

or *poor*. One might postulate that there was an immuno antibody against spermatozoa, but this seems unlikely since the S P M test using semen from the husband and blood serum from the wife could be classified for all these couples as *good*.

Besides the possibility of the presence in the cervical mucus of material with a damaging influence on the motility of the spermatozoa, it may also be possible that certain materials necessary for maintaining spermatozoal motility have been absent.

In cases 83, 89 and 104, besides the homologous test, the heterologous S P M test (semen of the husband with cervical mucus of another woman) was *negative, bad or poor*. The Sims-Huhner tests with these couples were also *negative, bad or poor*. The conclusion is that the semen of the men involved lacked the capacity for good penetration into cervical mucus. It was noticed that in one of these men (no. 83) the semen after ejaculation exhibited no clotting. The semen was ejaculated as a watery liquid and remained so after ejaculation. This phenomenon has been described by SOBRERO and MACLEOD in the immediate post coital test (SOBRERO and MACLEOD 1962).

In cases 100 and 123, the discrepancy between the quality of the semen (*passable*) and the result of the S P M test (*poor* and *bad*) can probably be ascribed to the poor motility of the spermatozoa at the commencement of the test. In both cases, the result of the heterologous S P M test was also *poor* and *bad* respectively.

Beside the cases where the result of the S P M test was poorer than might have been expected on the basis of the fertility assessment of the semen used, from Table 3e it can be seen that, of the 55 semen specimens assessed as *bad* or *poor* (group 2 and 3), there were 14 with an S P M test which was classified as *fair* or *good*. It is possible that very good "hospitality" of the cervical mucus has been able to compensate for the semen.

In a study of the main table (Table 3) it can be seen that the way in which migration of the spermatozoa in the cervical mucus took place with the different S P M tests presents a widely varying picture. In 49 cases, the qualitative motility of the spermatozoa at a distance of 5 cm. from the semen reservoir after two hours is better than at a distance of 1 cm. In 15 cases the qualitative

motility is the same at both places. In 25 cases the qualitative motility at a distance of 5 cm. is poorer than at 1 cm.

The reason for this difference is not completely clear. It is possible that after penetration, the low-vitality spermatozoa were unable to complete the journey through the column of cervical mucus within the glass capillary and even at the beginning of the journey, lag behind. The vital spermatozoa reached their goal. Because of this, relatively many more poorly motile spermatozoa could be seen after two hours in the glass capillary at a distance of 1 cm. than at 5 cm.

It is also possible that the journey through the column of cervical mucus so "tired" the spermatozoa that their motility at the end of this journey had been markedly reduced and had become poorer than at the beginning. The reason for this "rapidly produced exhaustion" may lie with the spermatozoa themselves, but may also be the result of a form of cervical hostility which damages the motility of the spermatozoa during their 5-cm-long journey.

In any event, it is obvious that chances of fertilization are more favourable when the spermatozoa have a better motility at a distance of 5 cm. in the capillary than at 1 cm., rather than when the opposite is the case.

2. *The results with cervical mucus having one or more physico-chemical properties which made it unfavourable for penetration, migration and survival of spermatozoa*

In Table 4 the results are shown of the homologous S P M test of 50 different couples, where the cervical mucus used varied in one or more physico-chemical properties from the normal values given on page 39. The semen used had very good penetrative and migratory qualities, established on the basis of results of the heterologous S P M test (semen of the husband, normal cervical mucus from the ovulation period of another woman). In all cases there was a spermatozoal density of at least 60 million per cc.; the motility was at least 60 % gr. 3, and at least 60 % normal head forms were present.

From Table 4 it can be concluded that the viscosity of the cervical mucus was the most important physico-chemical property affecting spermatozoal penetration and migration.

In the 21 cases where the viscosity of the cervical mucus was less than 5.5, the SPM test on 10 occasions (48 %) was described as *fair*, *good* or *excellent*. In the 29 cases where the viscosity was greater than 5.2, the highest classification was *poor*. In the 17 cases where the cervical mucus had a viscosity of 9 or more, slight penetration could be detected in only 3 cases. In the other 14 of these cervical mucus specimens, despite good penetration and migration qualities of the spermatozoa used, no penetration at all took place. The highest classification within this group of 17 was *bad*.

The same conclusion as could be drawn from an investigation concerning the results of the Sims-Huhner test (Kremer; publication in preparation) can also be drawn here, namely, that to a certain degree *good semen can compensate for increased viscosity of cervical mucus as far as penetration and migration potential of spermatozoa are concerned*.

This compensatory mechanism fails, however, when the viscosity rises above a certain value. In the Sims-Huhner test, a value of approximately 8 was found as the viscosity limit. Below this value the possibility of compensation existed. That this value is lower in the SPM test, namely between 5 and 6, possibly results from the fact that in the Sims-Huhner test penetration of the spermatozoa into the cervical mucus can begin immediately after ejaculation, whereas in the SPM test this cannot begin before the semen has been transported to the laboratory under non-physiological conditions. It is probable that spermatozoa from fresh semen are better able to overcome increased viscosity of cervical mucus than spermatozoa from semen which is often more than an hour old. Also, *in vivo*, the cervical mucus makes contact with the *first part of the ejaculate* (see fig. 21, 22) which, per unit volume, is richer in actively-motile spermatozoa than the total ejaculate. For performance of the SPM test, a sample is taken from *the total ejaculate*.

Botella-Lluisa does probably not believe in a "viscosity limit". He postulates that "high-quality spermatozoa" are able to penetrate in sufficient numbers, and in the active state, even in very viscous or very infected mucus (Botella-Lluisa 1966).

From Table 4 it can further be seen that in the first 21 cases, where the result of the SPM test failed on 11 occasions to attain the classification *fair*, the fern test was disturbed in 8 of these 11 cases, i.e. it was not maximally positive. However, a pH of 6.3-7, which according to the normal values given on page 39 must be considered as an abnormal property of the cervical mucus, had, as shown in Table 4, no obviously adverse effect on the result of the

S P M test. In 5 cases where the viscosity of the cervical mucus was lower than 4 and the pH varied from 6.3-7 (case 1, 3, 7, 12 and 15), the result of the S P M test was always *fair, good* or even *excellent*. In all cases where the „Spinnbarkeit” was 30 mm. or less, the result of the S P M test was always *poor, bad* or *negative*.

In summary it can be said that in the 50 cases in Table 4 with a viscosity of cervical mucus higher than 5.2, the S P M test was always *poor, bad* or *negative*. With a viscosity of 5.2 or less, the result of the test was clearly adversely affected if the fern test was disturbed or the „Spinnbarkeit” was 30 mm. or less. A pH from 6.3-7 had no obviously adverse effect on the result of the S P M test. No influence was seen of the result of the glucose contents.

3. *The results with heterologous cervical mucus the physico-chemical properties of which agreed with the normal values for cervical mucus from the ovulation period*

In the course of the sterility investigation a heterologous S P M test (cross test) took place at least once with each couple. The semen of the husband was tested against normal cervical mucus from another woman, obtained during the ovulation period.

The results of this test have not been shown in tabular form.

4. *The results using normal cervical mucus from the ovulation period in order to determine the rate of progression of spermatozoa therein at room temperature*

To obtain an impression of the rate of progression of spermatozoa from “good semen” into “good cervical mucus”, the rate of progression of spermatozoa was investigated in 54 S P M tests. The semen and cervical mucus used for these tests was derived from 54 different couples. The cervical mucus complied in all cases with the criteria given on page 39 for normal cervical mucus from the ovulation period. The semen in all cases had a spermatozoal density of at least 20 million per cc. and a spermatozoal motility of at least 40 % gr 3. The morphology of the spermatozoa in the majority of cases was such that at least 60 % of the spermatozoa possessed normal head forms. In the cases where less than 60 % normal head forms were found, the semen specimen

in question could still be classified as *passable* or *good* on the basis of the classification on page 31.

The determination took place 30 minutes after commencement of the test. The time which the spermatozoa needed to cover 5 mm. in the glass capillary (from 3 to 3¹/₂ cm.) was determined.

The results of this investigation are shown in Table 5. From this table it can be seen that the average speed of spermatozoa from semen, classified as *good* or *passable*, in normal cervical mucus at R T was 1.8 mm. per minute. The range was 1-2.8 mm.

5. *The results with blood serum as penetration medium*

Blood serum used as penetration medium in the S P M test was taken both from the deep-freeze depot (group AB Rh +) and from the wife in question. The object of this double test was to determine if the blood serum of the wife could possibly have an immobilizing effect on the motility of the spermatozoa of her husband. The results of this investigation are given on page 79.

Besides acting as a control for detecting immobilizing substances in the blood serum of the wife, the S P M test with blood serum AB Rh + served as longevity test for the spermatozoa.

The motility of spermatozoa in the homologous semen plasma cannot be considered a measure of the longevity of the spermatozoa themselves, because it is possible that materials are present in the seminal plasma which are harmful to the spermatozoa. Thus it appeared of value to transfer the spermatozoa from their normal medium into another medium, the composition of which fulfilled their biological requirements. In this way, the longevity of the spermatozoa could be determined in a medium, which to a large extent, corresponded to the fluid in the tubal lumen. Based on the investigations of MARCUS (1966) blood serum was considered to be such a medium.

The results of this *longevity test* are not tabulated in this thesis. However, on the basis of experience with this test, a classification was made regarding the assessment (see page 62).

To obtain an answer to the question as to what must be considered the "minimum longevity" for fertile spermatozoa in blood serum, the results of the *longevity test* were studied in 310 couples where the wife had been pregnant at least once.

From this investigation, except in one case, it could be seen that in blood serum at 37° C. the spermatozoa of the 310 men examined had a duration of motility of at least 24 hours. In 52 cases, the duration of motility was more than 24 but less than 48 hours. In the other 257 cases, the duration of motility in the test serum was at least 48 hours.

The above investigation suggests that the chance of conception is slight when the longevity of spermatozoa in blood serum is less than 24 hours at a temperature of 37° C.

C. Investigations with the S P M test to determine how long after coitus spermatozoa from the intravaginal seminal pool can penetrate into the cervical mucus

To determine how long after coitus spermatozoa maintain their motility in the intravaginal seminal pool, and are able to penetrate and migrate from there into the cervical mucus, 10 couples were investigated.

In these 10 couples no indication was given in either partner which could cause reduced fertility. The intravaginal semen of the 10 couples was examined at intervals of 5, 10, 15, 20, 35, 60 and 120 minutes after coitus. A drop of fluid from the intravaginal seminal pool was drawn up using a 2 cc. syringe fitted with a thin plastic cannula and without the introduction of a speculum. In this way admixture of vaginal transudate and semen was prevented as much as possible.

The pH of the drop of fluid obtained and the qualitative motility of the spermatozoa present in this drop were determined. Also 10 minutes, 20 minutes, 35 minutes and 1 hour after the intravaginal semen application, an S P M test was performed with semen which had been obtained from the intravaginal seminal pool at these intervals. As penetration medium, cervical mucus was used which had been taken from the cervical canal before the intravaginal semen application. In all cases this cervical mucus satisfied the normal values given on page 39 for cervical mucus from the ovulation period.

On the 10 couples, the above investigation was performed 14 times. The results are given in Table 6. From this table, the following conclusions can be drawn:

1. The longer the stay of the spermatozoa in the intravaginal seminal pool, the poorer the results of the S P M test. The spermatozoa which had remained for 20 minutes in the intravaginal seminal pool were, in the majority of cases, seen to be still capable of giving a S P M test classified as *good or fair*. A stay of 35 minutes in the intravaginal seminal pool was seen to have influenced the result of the test very unfavourably. Couple no. 6 was an exception. The result of their S P M test, after an intravaginal stay of the spermatozoa of 35 minutes, could still be classified as *good*. An intravaginal stay of the spermatozoa of 1 hour with this couple still gave a penetration test classified as *fair*. With the other couples, the S P M test with spermatozoa which had been in the intravaginal seminal pool one hour, was *bad or negative*.
2. There is a clear relationship between the pH of the intravaginal seminal pool and the motility of the spermatozoa 1 and 2 hours after the intravaginal semen application. Only in those cases where the pH was higher than 6, one and two hours after the intravaginal semen application, were spermatozoa still encountered at these times with qualitative motility of 2 or more. With couple no. 10, a serious intravaginal trichomonas infection existed. This possibly is connected with the relatively high pH in the seminal pool, 1 and 2 hours after the semen application. With couple no. 6 no trichomonas infection existed. In this case, the relatively high pH in the vagina is a possible reason why the spermatozoa, which had remained in the vagina for one hour, could still give a penetration test with the classification *fair*.
3. Generally speaking, there is no point in taking measures to prevent semen reflux from the vagina later than $\frac{1}{2}$ hour after coitus.

D. Results of the investigations with the S P M test as part of a contraception research project

In this project, use was made of four different progestational agents, namely: norethindrone acetate
megestrol acetate
lynestrenol
 Δ 5-10 lynestrenol.

These agents were used, each at a dose of 0.5 mg. per day, by a number of normal, fertile, healthy young women with normal, fertile husbands. The object of this was to alter the physico-chemical properties of the cervical mucus in such a way that a sufficient degree of cervical hostility would exist to prevent pregnancy. The results concerning the anticonceptual effect of this method, the nature and frequency of the undesirable side-effects and the acceptability of this method will be published separately (KREMER, BENNEN and HUISJES).

The effect of the four agents mentioned above on the physico-chemical properties of the cervical mucus and on the results of the S P M test are given in Table 7, Table 8, Table 9 and Table 10. It was impossible to determine the physico-chemical properties of the cervical mucus in all cases, since the quantity of cervical mucus was normally sharply reduced under the influence of the progestagen or because the viscosity was so high that a sufficient amount of mucus could not be sucked into the capillary of the consistometer.

From Tables 7, 8, 9 and 10 the following conclusions can be drawn:

1. The cervical mucus of the 48 women from Tables 7, 8 and 9, in 40 cases (83 %) was uniformly turbid. With the 8 women in Table 10 in only 2 instances (25 %) was this the case.
2. The viscosity of the cervical mucus in the cases from Tables 7 and 8 was, in general, markedly increased. In only one instance (no. 4, Table 7) was a value lower than 4 observed. In Table 9 the viscosity values are also too high for normal cervical mucus from the ovulation phase, but, on the average, less high than in Tables 7 and 8. In Table 9 there are 2 cases with values lower than 4 (no. 4, no. 11). In Table 10 in only 3 instances did the viscosity of the cervical mucus exceed the upper limit of normal values for cervical mucus from the ovulation period; in 5 cases the viscosity was 2 or less. In one of the three cases where the viscosity was high, it was later discovered that the woman was pregnant when the S P M test was performed (no. 3). In case no. 4 ovulation had probably already occurred 2 days previously so that the high viscosity in this instance may be due to endogenous progesterone production.
3. The fern test of the 48 cases from Tables 7, 8 and 9 was normal

(+++) in only one instance and abnormal in 45. In two cases no data were available on the result of the fern test. In the 8 cases from Table 10, the fern test was normal (+++) for 3 cases and abnormal for the other 5.

4. The result of the homologous S P M test with the 48 cases from Tables 7, 8 and 9 was always *negative, bad* or *poor*, except with case 4 in Table 7, where the result is classified as *fair*. In the 8 cases in Table 10, however, the S P M test on five occasions was *good* or *fair*.
5. Of the 48 control S P M tests from Tables 7, 8 and 9 where semen of the husband and normal cervical mucus from the ovulation phase of another woman were used, 44 obtained the classification *fair, good* or *excellent*. In the remaining 4 cases, where the result was *bad* or *poor*, the motility of the spermatozoa in the semen at commencement of the test was quantitatively less than 40 % and/or qualitatively less than grade 3.

There is thus a noticeable difference between the groups from Tables 7, 8 and 9 and the group in Table 10, as regards both the physico-chemical properties of the cervical mucus as well as the result of the S P M test. While in the couples from Tables 7, 8 and 9, the chance of spermatozoa from the intravaginal seminal pool reaching the cavum uteri could be considered extremely small, this must be considered as being very highly possible in the couples from Table 10.

On the basis of these results, it is considered probable that Δ 5-10 lynestrenol, which chemically is a progestational agent, has no progestational effect, at least not on the cervical glands of the woman. Account must even be taken of the possibility of an estrogenic effect of this agent on the cervical glands. In this case, Δ 5-10 lynestrenol could have a therapeutic effect in cases of undesired sterility resulting from cervical hostility.

To investigate this, 1 mg. Δ 5-10 lynestrenol daily was prescribed for 5 months continually to 20 women with primary sterility where the Sims-Huhner test and the S P M test were *negative, bad* or *poor* as a result of cervical hostility. Throughout its use the BTC was kept by the women to determine whether or not ovulation occurred normally. The cycle duration, which varied from 27 to 32 days

before the use of Δ 5-10 lynestrenol, remained unchanged during medication. The duration of menstruation and the quantity of blood loss also remained unchanged. All 100 cycles remained ovulatory; the time of ovulation was unchanged and was always about mid-cycle. An S P M test was performed during the second cycle. In 4 women the result was *negative* or *bad*, just as before medication; the cervical mucus did not meet the criteria for normal cervical mucus from the ovulatory phase. Normal ovulation cervical mucus was found in the remaining 16 women; the results of the S P M test were: 2 *poor*, 6 *fair*, 7 *good* and 1 *excellent*. Of these 16 women, 5 became pregnant in the 3rd or 4th month of treatment with Δ 5-10 lynestrenol. Because no instructions were given in this respect, these women continued medication until pregnancy was determined (2-3 weeks after absence of the expected menstruation). The duration of sterility in these women had varied from 3 to 12 years. Subsequently, 2 mg. Δ 5-10 lynestrenol were administered for 2 months to 5 women with cervical hostility. With this dosage too, the menstrual pattern continued unchanged and the cycle remained ovulatory. No pregnancies occurred in this group.

The conclusion is that Δ 5-10 lynestrenol, chemically a progestational substance, has an estrogenic influence on the cervical glands and can be used in the treatment of cervical hostility.

E. The S P M test as an aid to the investigation of the incompatibility between the blood serum of the wife and the spermatozoa of the husband

In a fertile woman the chance of conception is dependent in the first instance on the *number of functionally normal spermatozoa* which reach the cavum uteri. This factor determines whether sufficient spermatozoa can reach the tubes to provide a good chance of conception.

Because the spermatozoa in the tube must as a rule wait for some time before arrival of the ovum, the chance of conception in the second instance is determined by the *duration of motility* of the spermatozoa in the fluid inside the tubal lumen. Because the composition of this fluid resembles that of blood serum (MARCUS 1966) it seems reasonable to assume that in a couple a positive correlation

exists between their fertility and the duration of motility of the spermatozoa of the husband in the blood serum of his wife. When substances are present in the blood serum of the wife which exert an unfavourable influence on the duration of motility of the spermatozoa of her husband, a considerable chance exists that these substances will also occur in the secretion of the tube. It is also possible that these spermatozoon-immobilizing substances may also occur in other secretions of the tractus genitalis of the woman, for example in the cervical secretion.

That such materials exist in the form of antibodies against spermatozoa is probable on the basis of the results of immunological investigations (BASKEN 1932, BEHRMAN 1961, PAPASOV and ENTSCHEV 1963, FRANKLIN and DUKES 1964). The nature of the immune antibodies is still uncertain. BEHRMAN (1961) was of the opinion that they have some relationship with a blood group antagonism between the two marriage partners. PAPASOV and ENTSCHEV (1963) and FRANKLIN and DUKES (1964), however, found no such relationship in their investigations, between the occurrence of antispermatozoal antibodies and ABO-incompatible matings. FRANKLIN and DUKES consider the spermatozoal antibodies as agglutinins. In a series of 43 women with unexplained infertility, they found sperm-agglutinating antibodies in the blood serum on 31 occasions (72.1 %).

PAPASOV and ENTSCHEV, on the other hand, consider that these immune antibodies are immobilizins (immobilizing antibodies). They were able to detect these in 54 % of 56 women with unexplained infertility.

Besides antibodies against spermatozoa, account must also be taken of the possibility that other materials could be present in the blood serum of a woman and that these could have an immobilizing effect on the motility of spermatozoa. It can be imagined that certain products of metabolism, chemicals or medicaments, which have an immobilizing effect on spermatozoal motility, may occur in blood serum, in tubal secretion or in cervical secretion in such concentrations that the duration of motility of spermatozoa in these fluids could be abnormally short.

To check whether or not, with a couple from the sterility clinic, the serum of the woman had an immobilizing effect on the motility

of the spermatozoa of the husband, an SPM test was performed at least once with semen of the husband and blood serum of the wife. A control SPM test was performed simultaneously with AB Rh + blood serum from the deep-freeze depot. This spermatozoal immobilization test was considered *positive* when at the 8 hour check on the homologous test, progressively motile spermatozoa were observed for the last time, while in the control test, the spermatozoa were progressively motile for 48 hours or longer.

If in two different determinations, performed at an interval of at least a week, progressively motile spermatozoa were observed for the last time after 24 hours in the homologous test and after 48 hours or longer in the control test then the test was classified as *weakly positive*.

With 278 couples, the blood serum of the wife was investigated in the way described above. It was seen that the spermatozoal immobilization test produced a positive result in only two cases. With five couples, the result was weakly positive. These 7 cases involved couples with unexplained infertility. Serum was investigated for sperm-agglutinating antibodies from these 7 women and also from 41 other women with unexplained infertility, but a negative immobilization test (Dr. PH. RÜMKE, Antoni van Leeuwenhoekhuis, Amsterdam). In 5 of the 48 women, sperm-agglutinating antibodies were detected in a titre of 1 : 512, 1 : 128, 1 : 32, 1 : 4 and 1 : 4 respectively; the first one also had a positive spermatozoal immobilization test.

Although the investigation into the occurrence of spermatozoal immobilizing materials in the blood serum of the woman will be continued as part of the routine sterility investigation, *it seems unlikely on the basis of the results mentioned that these materials will occur frequently in cases of unexplained infertility*. This is in contrast to the findings of PAPASOV (1963) and FRANKLIN and DUKES (1964). These investigators were of the opinion that in more than half the cases of unexplained infertility, spermatozoal antibodies can be detected in the wife.

F. The SPM test for detection of spermatozoal immobilizing materials in the blood serum of the man

Materials may also occur in the blood serum of the man, which have an unfavourable effect on the motility of the spermatozoa. These materials may be excreted with the secretions of the epididymis, the seminal vesicles and the prostate. ROZIN (1960) showed that in some cases of asthenozoospermia, the motility of the spermatozoa can be markedly improved when the semen plasma of the man in question is replaced by semen plasma of a normal fertile man. It is possible that the asthenozoospermia in these cases is the result of spermatozoal immobilizing materials in the semen plasma. The most thoroughly investigated spermatozoal immobilizing materials which occur in blood and in semen of the man are the immune antibodies against spermatozoa. The first cases were reported in 1954 by WILSON and by RÜMKE. WILSON (1954) described two cases of men whose spermatozoa agglutinated spontaneously and whose blood serum and seminal plasma contained agglutinins against spermatozoa. RÜMKE (1954) reported two cases with sperm antibodies, both of which had oligospermia. RÜMKE and HELLINGA (1959) investigated 2015 men in sterile marriages for antibodies against spermatozoa. They found sperm agglutinins in the serum of 67 of them i.e. 3 per cent. Sixteen of these patients had azoospermia, due to bilateral occlusion of the vas deferens. This was a significantly greater number than among the azoospermic patients without sperm agglutinins. PHADKE and PADUKONE (1964) confirmed this observation. CRUICKSHANK and STUART-SMITH (1959) found sperm-agglutinating antibodies in 2 out of 14 men with orchitis. BANDHAUER (1963) found sperm-agglutinins in 9 out of 75 patients with infections of the genital organs.

BO FJÄLLBRANT (1965) examined the blood serum of 11 men whose semen showed marked spontaneous agglutination of the spermatozoa. An agglutination test as well as an immobilization test was done. Both were positive in all cases. The agglutinin titre varied from 1 : 32 to 1 : 16,384. The time until 90 % of the test spermatozoa were immobilized varied from 1 hr. 20 minutes to 24 hours. There was an approximate correlation between the agglutinin titre and the immobilization time.

In my own investigation, three groups of men were investigated for occurrence of spermatozoal immobilizing materials in their blood serum. In all cases there was primary sterility for which no reasons had been found in the wife.

On the blood serum of these men, a spermatozoal immobilization test was performed with the aid of the SPM. At the laboratory for immunology, Antoni van Leeuwenhoekhuis, Amsterdam (Dr. P.H. RÜMKE), an investigation was also made to determine if sperm agglutinins were present. The three groups were made up as follows:

Group A

This group consisted of 12 men with *agglutination of spermatozoa in the ejaculate*. From all these men, the spermatozoal agglutination test in the blood serum was positive. The spermatozoal immobilization test in 11 of these 12 men was positive or weakly positive (see Table 11).

Group B

This group consisted of 29 men with *obstructive azoospermia*. In 13 of these 29 men, the obstruction was the result of a bilateral total or partial regression of the wolffian duct. The diagnosis was made on the basis of the findings obtained by palpation of the intrascrotal organs, the fructose content of the ejaculate (AMELAR and ГОТЧКИСС 1963), and the pH of the ejaculate (KREMER 1967). In 7 men an obstruction existed in the ductus epididymis. This was diagnosed when the X-ray contrast photo of the sperm ducts showed these to be filled to capacity from the urethra to the cauda of the epididymis, and spermatozoa were observed in the fluid obtained by puncturing the head of the epididymis. In 2 men the epididymis was found on palpation to be hard and lumpy on both sides. Since biopsy of the testis showed signs of good spermatogenesis, location of the obstruction in the epididymis was evident without taking an X-ray contrast photo of the sperm ducts. In 7 men the nature and localization of the obstruction in the sperm ducts was not obvious. However, because in all these cases biopsy of the testis showed signs of good spermatogenesis, and the possibility of a retrograde ejaculation could be eliminated, the diagnosis of obstructive azoospermia was certain.

This group of 29 men included 9 men (31 %) with a positive spermatozoal agglutination test of the serum and 2 with a positive or weakly positive spermatozoal immobilization test of the serum (see Table 12). Patients nos. 1 to 5 inclusive are patients with bilateral regression of the wolffian duct. The other patients had obstructive azoospermia of different origin.

Group C

This group consisted of 65 men with *asthenozoospermia*. In this group only men were included on whom a semen analysis had been done at least 4 times, within two hours after ejaculation, and in whose semen the quantitative motility of the spermatozoa was always less than 40 % and the qualitative motility was always less than grade 3.

Of these 65 men, 9 had a positive spermatozoal agglutination test and 4 a positive immobilization test (see Table 13).

From Tables 11, 12 and 13 (with a total of 31 men), the following conclusions can be drawn:

- a. Of the 13 men where the spermatozoal agglutinin titre in the blood serum is higher than 1 : 256, 10 (77 %) had a positive or weakly positive spermatozoal immobilization test of the blood serum.
- b. Of the 4 men with a spermatozoal agglutinin titre in the blood serum of 1 : 256, in 2 instances (50 %) the spermatozoal immobilization test was positive.
- c. Of the 13 men with a spermatozoal agglutinin titre less than 1 : 256, 3 (23 %) had a positive or weakly positive spermatozoal immobilization test.

In general, a high sperm agglutinin titre in the blood serum is accompanied by a positive spermatozoal immobilization test. However, with a high titre of sperm agglutinins in the blood serum, the immobilization test can be negative (patient no. 6 from Table 12 and patient no. 3 from Table 13). A low spermatozoal agglutinin titre and even a negative spermatozoal agglutination test in the serum can also be accompanied by a positive immobilization test (patient no. 7 from Table 11 and patient no. 8 from Table 13).

From Table 11 it can be seen that despite quite a high titre of spermatozoal agglutinins in the blood serum, the motility and the duration of motility of the spermatozoa in the ejaculate can still be fairly good (patient no. 2, no. 6 and no. 8). It seems doubtful in these cases that absence of pregnancy in the wives can be ascribed to the immunological abnormality of the husbands.

From an investigation of 174 ejaculates, obtained from men whose wives were pregnant, it could be determined that obvious tail agglutination existed in the semen of 4 of them. This indicates that spermatozoal agglutination in the semen is *not always* accompanied by sterility.

From Table 13 it can be seen that in the 10 men with asthenozoospermia, a close relationship exists between the qualitative motility of the spermatozoa on the arrival of the ejaculate at the laboratory and the result of the spermatozoal immobilization test. In the cases where the qualitative motility of the spermatozoa on arrival of the ejaculate was smaller than 1, the spermatozoal immobilization test was always positive.

G. Relationship between the morphology of the spermatozoa in the semen and of the spermatozoa which have penetrated from this semen into the cervical mucus in the capillary of the S P M

An investigation was carried out to determine a possible correlation between the morphology of the spermatozoa and their capacity to penetrate into and to migrate through cervical mucus.

With the aid of the S P M a penetration test was carried out with 23 ejaculates from 23 men, who had enrolled in the sterility clinic with their wives. Normal cervical mucus from the ovulation phase was used as medium. The cervical mucus specimens were not always obtained from the wife. When the physico-chemical properties of the wife's cervical mucus were unsuitable for good penetration and migration of the spermatozoa, normal cervical mucus from the ovulation phase of another woman was used. Approximately 8 hours after the initiation of the test, the capillary of the S P M, 6 cm. long, was broken in the middle. From that half furthest from the semen reservoir, the contents were smeared onto a glass slide and coloured. A smear was also made of the semen immediately after receipt of

the ejaculate. This smear was coloured in the same way as the cervical mucus.

The morphology of the spermatozoa in the two smears was examined. The results of this investigation are shown in Table 14. From this table it can be seen that the percentage of spermatozoa with abnormal headforms decreases on an average of 45 % (with a range of 12-88 %) after arrival in the second half of the glass capillary. The reason is not clear. It is possible that morphologically abnormal spermatozoa are functionally inferior, and therefore many remain behind in the semen or in the first half of the capillary of the SPM. A second possibility is that an abnormal headform hinders migration of spermatozoa through cervical mucus.

chapter 4

comparative investigation of the results of the Miller-Kurzrok test and of the SPM test

The results of the classic MILLER-KURZROK test and those of the S P M test with the sperm penetration meter are only comparable to a certain degree, because the latter test produces data of certain kinds which cannot or can only partially be obtained with the former test. These data relate to the linear progression of the spermatozoa in the cervical mucus, the qualitative motility of the spermatozoa after they have travelled a certain distance through the cervical mucus, and the duration of motility of the spermatozoa in the cervical mucus. That these data can be obtained by the use of the S P M is mainly due to the fact that with this technique:

- the water channels in the cervical mucus are, as it were, “pulled” out straight (see page 47),
- the surface of contact between semen and cervical mucus is always easily produced,
- drying-out of the material is limited to a minimum.

In assessment of a comparative investigation between the two *in vitro* spermatozoal penetration tests, these differences must be taken into account.

Table 15 gives the results of 52 investigations in which a MILLER-KURZROK test and an S P M test were simultaneously performed with the same semen and the same cervical mucus. The semen as well as the cervical mucus were in all cases obtained from different couples. The semen in all cases had a spermatozoal density of at least 20 million per cc., a spermatozoal motility of at least 40 % gr 3, while at least 50 % of the spermatozoa had normal head forms. The physico-chemical properties of the cervical mucus were in some cases fa-

avourable for spermatozoal transport and in other cases unfavourable.

The numbers in Table 15 are so chosen that the degree of phalanx formation in the MILLER-KURZROK test decreases in groups from no. 1 to no. 52.

From Table 15 the following conclusions can be drawn:

1. There is an obvious relationship between the degree of phalanx formation in the MILLER-KURZROK test and the viscosity of the cervical mucus. A high viscosity normally accompanies marked phalanx formation. Cases 42, 43 and 44 were an exception to this. Such a high viscosity existed that the cervical mucus could not be sucked up into the capillary of the consistometer; the phalanx formation in these cases was slight.
2. As the phalanx formation in the MILLER-KURZROK test decreases, the penetration of the spermatozoa into cervical mucus increases, both in the MILLER-KURZROK test itself and in the test with the sperm penetration meter. An exception to this rule existed with cases 42, 43 and 44 where, despite sporadic phalanx formation, practically no penetration into the cervical mucus took place.
3. In some cases the MILLER-KURZROK test was strongly positive (+ + +) and the S P M test was *negative, bad or poor* (nos. 8, 12, 26 and 41). In cases 8, 26 and 41 a dense spermatozoal penetration into the S P M could be seen, especially at a distance of 1 cm. from the beginning of the glass capillary. However after 2 hours the progressive motility of the penetrated spermatozoa had become less than 1 throughout the glass capillary. In these cases the S P M test gives a more correct impression of the behaviour of the spermatozoa in the cervical mucus than does the MILLER-KURZROK test.

In case no. 12, no spermatozoal penetration into the capillary of the S P M had taken place. One cannot eliminate the possibility of *pseudo-penetration* in the MILLER-KURZROK test, i.e. that a thin layer of semen had flowed over a portion of the cervical mucus while the cover slip was being placed on top, although during the assessment special attention was paid to whether the spermatozoa, which had passed the dividing line

between semen and cervical mucus, were situated at the same level as epithelial or other cells in the cervical mucus.

4. In 5 cases (nos. 17, 28, 38, 40 and 49) penetration into the cervical mucus with the MILLER-KURZROK test was much poorer than the results with the S P M test would have led one to expect. The reason for this is not clear. In all 5 cases the quality of the cervical mucus and the quality of the semen were such that good spermatozoal penetration could be expected. Since in setting up the MILLER-KURZROK test it is sometimes difficult to obtain a good contact surface between semen and cervical mucus, and since air is sometimes present between the two fluids which can appreciably hamper spermatozoal penetration into the cervical mucus, it is possible that the poor results obtained with the MILLER-KURZROK test in the cases mentioned above, may have been due to these "exogenous factors".
5. In one case (no. 52) with both the MILLER-KURZROK test and also the S P M test, the penetration of spermatozoa into the cervical mucus was extremely slight. This was an instance where the spermatozoa, despite good density and good motility, lacked the capacity to penetrate into normal cervical mucus from the ovulation period.

The final conclusion from this comparative investigation is that the S P M test produces more information and more reliable results than the classic MILLER-KURZROK test. The S P M test is also a better representation of the conditions *in vivo* than the MILLER-KURZROK test. In the glass capillary of the sperm penetration meter, exactly as in the cervical canal, the cervical mucus is brought into a state which ensures *directional spermatozoal transport*, due to the elongation and alignment of the long macromolecular filaments in the cervical mucus.

chapter 5

the relationship between the SPM test and the Sims-Huhner test

Part I Review and discussion of the literature concerning the Sims-Huhner test

In 1866 Marion Sims described for the first time a test in which immediately post coitum a small quantity of cervical mucus was taken from the cervical canal and microscopically investigated for the presence of spermatozoa. His contemporaries, however, hardly appeared ready for such an investigation, as appears from the comment in the *Medical Times and Gazette* in which his procedure was described as “this dibbling in the vagina with speculum and syringe - incompatible with decency and selfrespect”.

The same test was again described in 1913 by Max Huhner. It appeared to be unnecessary to perform the test immediately after coitus; in a normal fertile couple, many actively motile spermatozoa were still demonstrable in the cervical mucus several hours post coitum.

In the literature one meets this test under the name Sims test, Huhner test or Sims-Huhner test. It is also called the postcoital test. Strictly speaking, this last name is incorrect. A postcoital test can also be performed with material from the intravaginal seminal pool or with moisture aspirated from the endometrial cavity (KLEEGMAN 1936, WEISMAN 1940).

One might wonder if an *in vitro* spermatozoal penetration test performed *lege artis*, using cervical mucus and semen from the couple in question, makes the Sims-Huhner test superfluous. The *in vitro*

spermatozoal penetration test produces in fact the same data as the Sims-Huhner test, namely the *density* with which the spermatozoa have penetrated the cervical mucus and the *degree of motility* which these spermatozoa still possess after a certain number of hours.

On the other hand, one might wonder if there is any need for an *in vitro* spermatozoal penetration test, when in fact, using the simpler Sims-Huhner test, more or less the same data can be obtained.

To be able to answer these questions, it is important to investigate what happens to the spermatozoa which have penetrated the cervical mucus in the cervical canal post coitum. On this point, two diametrically opposed theories exist.

A. The "filter" theory

According to some investigators (MOGHISSI *et al.* 1964) normal spermatozoa pass the mucus in the cervix uteri in a very short time, provided that the mucus possesses the properties normal to the ovulation phase. The spermatozoa which remain behind and are observed in the Sims-Huhner test must be the abnormal, poorly-motile spermatozoa of low vitality. They therefore question the validity of the Sims-Huhner test as an index of "compatibility" between cervical mucus and spermatozoa, particularly when the test is performed a number of hours post coitum. The normal actively-motile spermatozoa will then have passed the cervical mucus long before and in the meantime will have arrived in the upper part of the female genital tract.

PERLOFF and STEINBERGER (1964) were also of the opinion that the cervical mucus might possibly be considered as a "filter" in which the abnormal spermatozoa are held fast on their way to the upper part of the female genital tract.

The results of the investigation, mentioned on page 83 and in Table 14 of this thesis, are another support for the "filter" theory.

Should the above-mentioned conclusion prove to be correct, then the Sims-Huhner test, when carried out several hours after coitus, as is normally the case, must be interpreted in a completely different manner from that normally used hitherto.

A negative Sims-Huhner test, in the presence of normal cervical mucus, normal semen, normal anatomical distance ratios of the genitals, and good coitus technique, should in fact be taken as a favourable sign.

The presence of a few non-motile or stationary motile spermatozoa should be regarded as equally favourable under the above mentioned conditions. Only in cases of poor semen qualities or abnormal cervical mucus should such an observation be considered as a possibly unfavourable sign. When, however, in the post coital test, many spermatozoa per visual field are encountered, this should be regarded as unfavourable, even if the motility of these spermatozoa is good. In such cases, little or no ascent of spermatozoa to the upper part of the female genital tract takes place.

Only a Sims-Huhner test performed immediately post coitum could, according to the above view, still be interpreted according to the usual criteria. Then a large number of actively-motile spermatozoa in the cervical mucus is indeed a favourable condition, while a negative or a bad test in such a case is unfavourable.

On this basis, the results of a good *in vitro* spermatozoal penetration test appears to be more representative of spermatozoal penetration *in vivo*, than a Sims-Huhner test performed several hours post coitum (MOGHISSI *et al.* 1964).

There are, however, some facts which do not tally with the "filter" theory.

In the first place, it happens repeatedly in fertile as well as infertile couples that two or three days after coitus, actively motile spermatozoa are still seen in the Sims-Huhner test. PERLOFF and STEINBERGER (1964) were able to show a considerable number of actively motile spermatozoa in the cervical mucus in 9 patients, as much as 5-7 days after A.I.D. (Artificial Insemination with Donor sperm). It is difficult to believe that such motility duration in the cervical mucus would be achieved by functionally "inferior" spermatozoa.

A second argument against the "filter" theory is that in a coloured preparation of the Sims-Huhner test, the percentage of morphologically normal spermatozoa is high, even much higher than in

the original semen (SIMMONS 1946, HARVEY and JACKSON 1948, COHEN and STEIN 1951, BERGMAN 1955).

Finally, it appears from the results of various investigators that after a good Sims-Huhner test, even when this is performed several hours after coitus, pregnancy occurs much more frequently than after a bad or negative Sims-Huhner test.

Southam and Buxton (1956) investigated the results that had been obtained from the Sims-Huhner test during the conception cycle in 40 women with normal cervical mucus. In 24 of these women, that is 60 per cent, the Sims-Huhner test was found to be good. The test was performed between 3 and 24 hours post coitum. These tests were considered as good where more than 15 progressively motile spermatozoa were observed per high-power field.

Of 10 women who, in an investigation of Perloff and Steinberger (1964), became pregnant during the cycle in which insemination with donor sperm had taken place, there were 9 with whom progressively motile spermatozoa were observed in the cervical mucus, as much as 24 hours after the successful insemination.

The figures of Danezis *et al.* (1962) point in the same direction. On 140 women treated for infertility, in whom pregnancy occurred after a period of time, 316 Sims-Huhner tests were performed. In only 84 instances was a negative test recorded, i.e. in approximately 27 per cent of the cases. Of 406 women who did not become pregnant, the Sims-Huhner test was negative in 49 per cent.

The facts mentioned above cannot be explained by means of the "filter" theory.

B. *The "depot" theory*

A completely different view of the significance of the Sims-Huhner test is inherent to the theory of SCHUSTER. According to this investigator, the spermatozoa after intercourse are held provisionally in store in the cervical mucus until, after ovulation, the follicle fluid comes in contact with the cervical mucus via the fallopian tube and the uterus. This connecting pathway between tube and cervix forms a suitable medium for spermatozoa to reach the ovum in the ampullar portion of the tube. According to SCHUSTER, the follicle fluid contains chemotactic materials by means of which the spermatozoa are attracted. The concentration of these chemotactic materials is higher at the uterine opening of the tube than elsewhere in the uterine cavity where, because of dilution with uterine

secretion, the concentration of chemotactic material decreases. The spermatozoa move in the direction of the highest concentration of chemotactic material. In this way the majority of the spermatozoa which have entered the uterine cavity, arrive in the tube where they encounter the newly released ovum. This, therefore, could also explain how it is that spermatozoa do not lose their way in the large uterine cavity, with an area of approximately 2300 mm². Were this purely a question of chance, then only one in 14,000 of the spermatozoa entering the uterine cavity would reach the tube opening. The latter is extremely small, only 0.16 mm.² (SCHUSTER 1955).

Schuster based his theory on quite a simple experiment. An erythrocyte pipette was sawn through in the "bulge". In the "cup" a plug of cotton wool was laid containing follicle fluid, cervical secretion, uterine secretion or an extra-genital body fluid. Onto this, a drop of Baker's solution was pipetted from above, so that the solution passed down into the capillary of the erythrocyte pipette via the cotton wool plug. The tip of the pipette was placed in a container with fresh semen and after 15 minutes, the cotton wool plug was streaked out on a glass slide. The number of spermatozoa per visual field was considered as a measure of the chemotaxis of the investigated fluid. From this it was found that the chemotaxis of follicle fluid was considerably greater than that of any other genital or extra-genital body fluid (Schuster 1955).

The results of the investigation by BROWN (1944) argue against the "depot" theory. After hysterectomy the uterine cervix was placed in a dish of fresh semen. Every ten minutes fluid from the infundibular portion of the fallopian tubes was examined for the presence of spermatozoa. In 3 out of 6 uteri examined in this way, spermatozoa could be detected 65-75 minutes after the cervix had been brought into contact with the semen. MOGHISSI (1968) repeated the investigations of BROWN with 4 excised human reproductive tracts prepared for sperm migration. However, he could not recover spermatozoa from the fluid in the uterine cavity or from the fimbriated end of the tubes.

The investigations of RUBINSTEIN *et al.* (1951) also argue against the "depot" theory. These investigators applied 2 cc. fresh semen deep into the vagina in each of 51 women, ¹/₂-50 hrs. before hysterectomy. Motile spermatozoa were found after the hysterectomy in the washings from the uterine fundus and/or tubes in 11 out of the 15 women who were operated on before the 10th day of the

cycle. Although the authors did not mention the length of the cycle, it is still very probable that the migration of the spermatozoa to the higher parts of the genital tract had taken place before ovulation in those 11 women.

A third argument against the "depot" theory is that the post coital test with a specimen obtained from the endometrial cavity (the fundal test) is often positive during the pre-ovulatory phase. In 920 cases in which both the Sims-Huhner test and the fundal test were carried out shortly before ovulation, GRANT (1958) found that a positive fundal test was accompanied by a negative Sims-Huhner test in 10 per cent of the cases. However, the objection to the fundal test is that the cannula with which the fluid is drawn off from the endometrial cavity has first passed the cervical canal. This can be the cause of a false positive fundal test. For this reason, FRENKEL (1961) developed a method by which contamination of fundal fluid with cervical contents could be avoided. Before coitus he inserted into the uterus a thin polyethylene cannula with one end closed. The closed end was in the cervical canal, the open end in the cavity of the uterine fundus. After coitus the closed end was cut off and fluid was drawn off from the uterine fundus via the cannula. Using this technique he was able to obtain motile spermatozoa from the uterine fundus in 12 women in whom the test was performed between the 6th and 8th day of the cycle.

Before assessing the Sims Huhner test it is important to consider whether the cervical mucus is merely a *transit medium* for the spermatozoa through which normal spermatozoa pass in a short time, or a temporary "*abode*" from which the spermatozoa travel later to the higher regions of the genital tract, after ovulation.

Among other investigations, those of SOBRERO (1966) indicate the possibility of *rapid passage*. In 13 women in whom an intra uterine post-coital test was performed 4-5 minutes after coitus (with precautions to prevent contamination of the uterine contents with cervical mucus) he found motile spermatozoa in the fluid of the uterine cavity five times.

Many publications have appeared in the course of this century on the *hospitality* of cervical mucus for spermatozoa. These publications show that the duration of spermatozoal motility in normal

cervical mucus obtained during the ovulatory phase amounts to at least 40 hours (RUNGE, 1909, 48 hours; FRAENKEL, 1930, 8 days; HUHNER, 1936, 5 days; CARY, 1936, 84 hours; WILLIAMS and SIMONS, 1942, 72 hours; ROCK, 1949, 48 hours; TYLER, 1959, 134 hours; TIETZE, 1960, 96 hours; DANEZIS *et al.*, 1962, 5 days; PERLOFF and STEINBERGER, 1964, 7 days; NICKELSON, 1965, 6 days).

Therefore it is probable that on the one hand, the cervical mucus renders a rapid passage for spermatozoa, and, on the other, is so "hospitable" towards spermatozoa that they can retain good motility and normal fertility for a long time, and can migrate from the cervical mucus to the higher regions of the female genital tract a long time after coitus, both before and after ovulation.

When the Sims-Huhner test is performed some hours after coitus, which is generally the case with a routine sterility examination, it must be taken into account *that this evaluation is based on spermatozoa "left behind" in the cervical mucus.* However, the chance of pregnancy will presumably be determined much more by those spermatozoa which are in the higher regions of the female genital tract at the time of the Sims-Huhner test than by those left behind in the cervical mucus.

Yet it seems to me that the classic Sims-Huhner test, even when performed some hours after coitus, deserves an important place in the sterility examination. Even if it is regarded as a test for the spermatozoa which are left behind, important conclusions can often be drawn from the result of the test. It can be deduced from the presence in the cervical mucus of many spermatozoa with good motility that the husband's semen contains many spermatozoa with good motility (LÜBKE 1967), that there is no cervical hostility and that the couple presumably has a good coitus technique.

However, one must not conclude from this kind of result, mostly classified as *good* or *excellent*, that the cervical mucus in question affords the spermatozoa a good passage. A fundal test must be performed to obtain data in this matter. Even less can conclusions be drawn if a few or no spermatozoa are seen a number of hours after coitus, or if the spermatozoa present move only in situ or very slowly in the cervical mucus. If in such a case the physico-chemical properties of the cervical mucus are normal for the ovulatory phase

(SEGUY and VIMEUX, 1933; SEGUY and SIMONET, 1933; MOENCH, 1934; LAMAR, SHETTLES and DELFS, 1940; VIERGIVER and POMMERENKE, 1944; CLIFT, 1945; PAPANICOLAOU, 1946; RYDBERG, 1948; ROLAND, 1952, 1958; COHEN, STEIN and KAYE, 1952, 1956), and if the semen fulfils the requirements for normal fertility (MACLEOD and GOLD, 1951, 1953, 1956), the male and female copulatory organs show no anomalies and coitus technique is optimal, then the possibility of rapid transport of the spermatozoa to the higher parts of the female genital tract must be reckoned with. Naturally a poor Sims-Huhner test of this kind need not signify a poor fertility prognosis. KLEEGMAN and KAUFMAN report two cases of pregnancy after coitus with a negative Sims-Huhner test and a positive fundal test (KLEEGMAN and KAUFMAN, 1966).

One would have to perform the immediate post-coital test on the cervical mucus in all cases in the fertility examination in order to prevent the negative influence of rapid transport of spermatozoa through the cervical canal on the result of the test. However, this encounters practical objections in many cases. If the couple lives a long way from the clinic it is not always possible even to perform the Sims-Huhner test within two hours after coitus. Another solution would be always to perform a fundal test simultaneously with the Sims-Huhner test; then information would be obtained on whether the spermatozoa are capable of reaching the fundus uteri (KLEEGMAN and KAUFMAN 1966). However, the great objection to this test is that even when special precautions are taken, as indicated by KLEEGMAN and KAUFMAN (1966) and by SOBRERO (1966), contamination of the cavum uteri with cervical mucus containing spermatozoa cannot always be avoided. In addition, a negative fundal test can equally indicate that no spermatozoa have migrated from the cervical mucus into the cavum uteri, as well as that all the spermatozoa have already disappeared from the cavum uteri into the tubes at the time of the test.

For the above reasons the fundal test is not performed as a routine examination in the infertility clinic of the University Gynaecology Clinic at Groningen.

In those cases where the Sims-Huhner test is *negative* or *poor* without there being special reasons for this (semen with poor quali-

ties, anomalies of the physico-chemical qualities of the cervical mucus, anatomical anomalies of the husband's or wife's genitals, incorrect coitus technique), the result of this test is compared with that of the S P M test. If it appears that the latter is classified as *good* or *excellent*, the possibility is taken into account that the poor result of the Sims-Huhner test must be ascribed to a rapid passage of spermatozoa through the mucus column in the cervical canal. In these cases a fundal test is performed.

If both the Sims-Huhner test and the S P M test are negative, without there being any explanation for this, other causes must be considered which can have an unfavourable influence on the penetration, migration and stay of the spermatozoa in cervical mucus (cervical hostility with normal physico-chemical properties, poor spermatozoal penetrability, etc.). Further diagnosis is then made by means of a cross test.

On the basis of the considerations mentioned above it seems to me that both the Sims-Huhner test and the S P M test have a place in the sterility examination. The data obtained with either test can often supplement the other.

Part II Materials and methods

The Sims-Huhner test was performed in 160 different married couples who attended the infertility clinic. In all cases the cervical mucus met the criteria for normal cervical mucus from the ovulatory phase, presented on page 39. The test was done between 2 hours and 8 hours after coitus.

The classification given on page 31 was used for evaluating the fertility of the semen. The semen was *sterile* in 13 husbands, *bad* in 7, *poor* in 42, *passable* in 41 and *good* in 57. The results of the Sims-Huhner tests were classified according to the following groups:

negative: no spermatozoa found

positive: one or more spermatozoa found

a positive Sims-Huhner test was qualified in the following way:

bad: up to 5 spermatozoa per dry HPF ($\times 400$) with motility of grade 1 or grade 1—
or any number of spermatozoa, but motionless or stationary motile (< 1)

- poor: up to 5 spermatozoa per dry H P F with motility between grade 1 and grade 3 or more than 5 spermatozoa per dry H P F with motility of grade 1 or grade 1—
- fair: up to 5 spermatozoa per dry H P F with motility of grade 3 or better or more than 5 spermatozoa per dry H P F with motility between grade 1 and 3
- good: more than 5 spermatozoa per dry H P F with motility of grade 3 or better
- excellent: more than 20 spermatozoa per dry H P F with motility of grade 3 or better

The results of the investigation are reproduced in Table 16. This table shows that *the percentage of positive Sims-Huhner tests increases as the fertility evaluation of the semen improves. Likewise, the assessment of the positive Sims-Huhner tests is better as the fertility evaluation of the semen falls into a higher grade.*

To calculate χ^2 the group "sterile" was not considered. Further rows 2 and 3 (*bad* and *poor*), columns *bad* and *poor* and columns *good* and *excellent* were taken together.

$$\begin{aligned}\chi^2 &= 34,252 \\ df &= 6 \\ P &< 0.0005\end{aligned}$$

Because all the 160 Sims-Huhner tests were performed more than two hours after coitus, the conclusion must be that *cervical mucus during the ovulation period possesses a depot function for spermatozoa with good motility.*

Yet there are still 22 (39 %) of the 57 cases in group 5 where the result was classified as *negative, bad* or *poor* in spite of the fact that the semen was evaluated as *good*. The result of the S P M test with cervical mucus from the ovulation period in these 22 couples was examined. In 6 cases the result of this test was also assessed as *negative, bad* or *poor*. But in the remaining 16 the result was *fair, good* or *excellent*. Before concluding that all the spermatozoa with good motility had travelled rapidly through the cervical mucus column in the cervical canal of these 16 women, another

possible explanation was sought for the discrepancy between the result of the Sims-Huhner test and the result of the S P M test. The results obtained in the routine sterility examination of these 16 couples were checked carefully once again. In the cases where the information was not complete, the couple was asked to come back for the history and examination to be completed.

Four women appeared to have an immobile retroversion of the uterus, and experienced pain with a deep intromission of the penis. It is not out of the question that the unfavourable result of the Sims-Huhner test in these four women was caused by an incomplete penis intromission during ejaculation.

There was one case of corporal hypospadias of the penis; the result of the Sims-Huhner test was not improved by fitting a condom with a small opening in the blind end before coitus as described by LEVIE (1961).

In two cases it was recorded that the ejaculation may have been incomplete.

A disturbed ejaculation as a result of an "obligatory" coitus must always be taken into account when evaluating the Sims-Huhner test and inquiries should be made on how the coitus in question proceeded.

In one case the ejaculate volume appeared to be less than 1 cc., in all the semen analyses (total of 5).

A small ejaculate volume, with otherwise good semen properties can be the cause of a bad Sims-Huhner test (M c L a n e 1965).

In one case the bad Sims-Huhner test could possibly be ascribed to a so-called "lethal factor" in the vagina (MASTERS and JOHNSON 1961, 1966). The immediate post-coital test showed that the progressive motility of the spermatozoa in the intravaginal seminal pool had completely disappeared within 10 minutes after coitus. The patient concerned was advised to use a vaginal douche with a slightly alkaline fluid during the ovulatory phase, immediately before coitus. This advice was followed and pregnancy occurred three months later.

With two couples, the husband was accustomed to continue the coital movements during and also after ejaculation. He did this in order to allow his wife to reach orgasm.

It is probable that this coitus technique exerts an unfavourable influence on the transition of the spermatozoa from the semen. The first part of the ejaculate which generally contains greater spermatozoal density and has better spermatozoal motility than the second (MacLeod and Hotchkiss 1942, Farris and Murphy 1960, Amelar and Hotchkiss 1965), is applied against the portio and remains there after the penis has been withdrawn from the vagina (see fig. 21 and 22). However, if the coital movements are continued during and after ejaculation, the qualitatively best part of the ejaculate will be removed from the portio. In addition, the ejaculate is mixed with the acid vaginal contents by the coital movements; this has an unfavourable influence on spermatozoal motility.

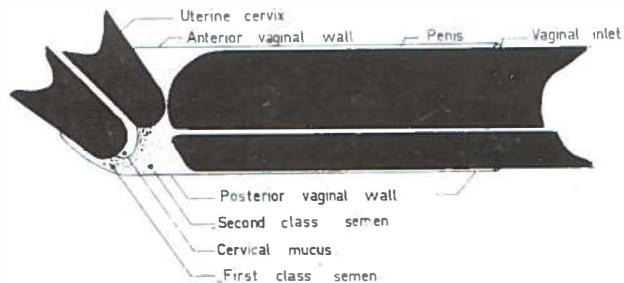

Fig. 21. Intravaginal situation during coitus, directly after ejaculation.

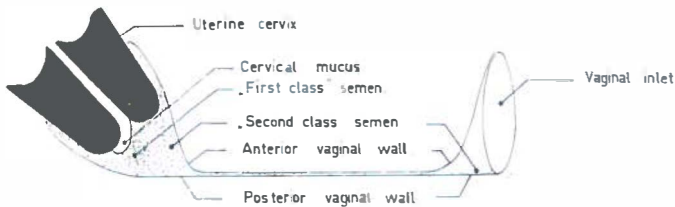

Fig. 22. Intravaginal situation after coitus.

In one case the husband's penis was abnormally short. In addition, coitus took place in a position where the wife kept her legs stretched.

A coitus position where the wife keeps her legs stretched is not uncommon. It may be considered as an expression of insufficient willingness for intercourse. Sometimes the wife keeps her legs stretched and closed together after intromission. Then the glans penis may not reach the uterine cervix. This can be the cause of an insufficient Sims-Huhner test, especially in cases of borderline semen. In such cases it is very important that as large a contact surface as possible is obtained between the ejaculate and the mucus protruding from the cervical canal. Therefore an optimal coitus technique can be considered as a method of *sperm utilization* (Kremer 1966).

No explanation was found in the 4 other cases of discrepancy between the results of the Sims-Huhner test and the SPM test. It is possible that in these cases the spermatozoa with good motility passed rapidly through the column of cervical mucus in the cervical canal to the higher regions of the female genital tract, with the inferior spermatozoa being left behind in the cervical mucus. Because the cervical mucus column is *not a static mass* but a slowly and continuously flowing quantity of fluid, the spermatozoa with little or no motility are transported out of the cervical canal and reach the vagina after a few hours. This can explain why the Sims-Huhner test can be *negative* in such cases.

The cross matching technique was applied in the 6 couples where the SPM test and the Sims-Huhner test gave a result which was classified as *negative, poor* or *bad*. The semen of the husband in question and normal ovulatory cervical mucus from another woman were used for this cross test. For three cases the cross test gave a good result. There was probably cervical hostility, in spite of the normal physico-chemical properties of the cervical mucus. In the three other cases the cross test also gave a bad result. In two of these cases there appeared to be slight tail agglutination of the spermatozoa. Possibly the antibodies against the spermatozoa had thereby diminished spermatozoal penetrability. No spermatozoal antibodies could be detected, either in the seminal plasma or in the blood serum of the third man. However, this man's semen showed the remarkable property that immediately after ejaculation the whole ejaculate was and remained thin and watery. This could not be ascribed to the absence of secretion from the seminal vesicles, because the amount of ejaculate (six different ejaculates from this man were examined) varied from 4 to 7 cc., the pH from 7.8 to 8.1 (KREMER, 1967) and the fructose content was always greater than 200 mgr % (AMELAR and HOTCHKISS, 1963). Because of the remarkable character of this phenomenon, the Sims-Huhner test was repeated in 4 different cycles in the couple in question during the ovulatory phase; the result was always *bad* or *negative*. The immediate post-coital test also gave a bad result. It is not clear how the absence of coagulation in the ejaculate could have had an unfavourable influence on spermatozoal penetrability.

In the literature I found the remarkable combination of absence of the coagulation phenomenon and bad spermatozoal penetrability only described by SOBRERO and MACLEOD who saw this three times in the immediate post-coital test (SOBRERO and MACLEOD, 1962).

Table 16 shows further that of the 42 couples where the husband's semen was classified as *poor*, the Sims-Huhner test was 12 times *fair*, twice *good* and once even *excellent*. The S P M test was *negative, bad* or *poor* in these couples. The discrepancy between the result of the Sims-Huhner test and that of the S P M test may be caused by the unfavourable influence which obtaining and transport of semen can sometimes have on spermatozoal motility. This was probably the case in 5 of these 15 men, where the spermatozoal density was greater than 40 million per cc. In view of the strong correlation which generally exists between spermatozoal density and motility in the ejaculate (MACLEOD and GOLD, 1951, 1953) it is probable that there was good initial motility of the spermatozoa in the ejaculate in these five cases. In 5 of the 15 cases, however, spermatozoal density was less than 20 million per cc. Yet a *fair* Sims-Huhner test was seen 4 times and a *good* Sims-Huhner test once. This could indicate that good cervical mucus can in some cases compensate for insufficient semen.

With 7 couples where the husband's semen was classified as *bad*, the Sims-Huhner test never attained the assessment *fair, good* or *excellent*. Here the good properties of the cervical mucus apparently did not compensate sufficiently to bring about a favourable Sims-Huhner test. Nor was this the case with 12 couples where the spermatozoal density in the husband's semen was less than 5 million per cc. (not mentioned as separate group in Table 16). Although in 3 of these cases the quantitative motility was more than 40 % and/or the qualitative motility more than grade 3, the result of the Sims-Huhner test was *negative* 10 times and *bad* twice.

Conclusions

1. Besides a "receptive" function and a "filter" function the cervical mucus during the ovulation period also possesses a "depot" function for normal spermatozoa.

2. If the Sims-Huhner test gives a bad result and the result of the S P M test is good, it may not be assumed without more evidence that spermatozoa have passed rapidly through the mucus column in the cervical canal. First, other causes should be sought which could explain this discrepancy. Such causes can be:
 - a. anatomical abnormalities of the male or female genitalia
 - b. disturbed ejaculation
 - c. small ejaculate volume
 - d. "lethal factor" in the vagina
 - e. insufficient intromission at the moment of ejaculation.
3. If both the Sims-Huhner test and the S P M test give a bad result, when this was not to be expected on the basis of the qualities of the semen and of the cervical mucus, the cross matching technique can be used to determine whether the cause lies in the semen or in the cervical mucus.
4. The manner of acquiring and transporting the ejaculate can be the cause of a difference between the results of the S P M test and of the Sims-Huhner test.
5. Good cervical mucus can compensate for insufficient semen, according to the results of the Sims-Huhner test. This compensatory mechanism is probably no longer functional if the husband's semen is classified as *bad* or if the spermatozoal density is less than 5 million per cc.

summary and conclusions

The aim of the spermatozoal penetration test *in vitro* (hereafter called the *penetration test*) is to determine whether, and to what extent, spermatozoa from a specimen of semen are able to penetrate cervical mucus or other fluids, the manner and velocity of movement, and how long and to what extent the penetrated spermatozoa remain motile in these media.

The *penetration test* can be carried out in various ways and under various conditions.

In order to form a routine part of an examination for fertility in man the conditions to be fulfilled by such a test are:

- a. the test shall be done with simple apparatus which is easily handled.
- b. the test shall be done with small quantities of the material under examination.
- c. the results shall be reproduceable.
- d. penetration density, penetration depth, velocity of migration and duration of motility of the spermatozoa in the fluid used in the test shall be determinable with reasonable accuracy.

Chapter 1 discusses two kinds of *penetration tests* i.e. the *cover-glass methods* and the *capillary methods*. The cover-glass methods have the disadvantage that after penetration the spermatozoa move through the penetration medium in non-rectilinear fashion and in random directions. Therefore no correlation exists between depth of penetration and distance travelled in the penetration medium. Also the continuous change of direction of movement makes

velocity of migration difficult to determine by the cover-glass methods. The cover-glass methods, finally, are generally not suitable to determine the duration of motility of the spermatozoa in the penetration medium at 37° C, as at this environmental temperature the material tends to dry out. The capillary methods allow the determination of penetration density, penetration depth, velocity of migration, and the duration of spermatozoal motility in the medium. However, the capillary methods described in the literature are either too complicated or yield insufficiently reliable results for inclusion as a routine item of the fertility examination of man.

For this reason a simple apparatus was constructed which appeared to satisfy the conditions. This apparatus was called the *sperm penetration meter* (hereafter referred to as the S P M).

Chapter 2 first describes the simple and cheap construction of the S P M, which can be put together in any instrument workshop possessing a glass-saw. Construction costs little and takes less than one hour. This is followed by a description of the manner of collection, transport, examination and storage of the materials used for the *penetration test* employing the S P M, prior to testing in the framework of examination for human fertility.

Before obtaining the semen, the subject was given printed instructions and a small, cylindrical glass bottle. Where cervical mucus was used as the penetration medium, this was obtained from the cervical canal with the aid of specially designed forceps, after which it was deposited on a microscope slide and placed in a moist Petri-dish until required for the test. When the cervical mucus was stored for longer periods, it was kept in glass capillaries closed at both ends with plasticine and kept in a refrigerator in a specially constructed holder. Serum used as penetration medium was obtained by venous puncture and centrifugation of the blood. Where necessary, the serum was kept deep-frozen.

For each ejaculate a *fertility-grade* was scored on the basis of density, quantitative and qualitative motility and morphology of the spermatozoa. This was scored on a points system. The cervical mucus was examined for *clarity*, *viscosity*, "*Spinnbarkeit*", *acidity*, *glucose* and ability to crystallize in a *fern-shaped* structure. Clarity was expressed in degrees. Viscosity was determined with a Scott-

Blair consistometer. "Spinnbarkeit" was determined by a method developed in this laboratory. Acidity and glucose content were estimated with paper test-strips. The fern-test was done by drying the cervical mucus on a microscope slide.

The latter part of Chapter 2 deals in detail with the technique of the penetration test with the S P M. (hereafter referred to as the S P M test). Before starting the test, 500 units of penicillin and 0.5 mg. of neomycin were added per ml. ejaculate, to prevent bacterial growth.

Chapter 3 describes the results of the S P M test.

Chapter 3A concerns the results of an investigation into the usefulness of the S P M test as part of the general examination for fertility in man.

This led to the conclusions that:

- a. passive transfer of spermatozoa from the semen filled reservoir into the glass capillary containing cervical mucus did not take place.
- b. passive transfer of spermatozoa from the semen filled reservoir into the glass capillary containing serum could be prevented by keeping the S P M horizontal and by moving it only carefully.
- c. environmental temperature influenced the results of the S P M test. The penetration density and migration velocity in serum at 40° C. and at 37° C. was higher than at room temperature, while duration of motility at 40° C. was shorter than at 37° C., and at 37° C. again shorter than at room temperature (Table 1).
- d. when human serum was used as a penetration medium in the S P M, the results of the test were better than when isotonic glucose-saline, colloidal plasma substitute or pasteurized human plasma albumin were employed (Table 2).
- e. deep frozen storage of serum did not alter the results of the S P M test when, after thawing, this serum was used as penetration medium.
- f. the results of the S P M test were sufficiently reproduceable to employ this test as a routine part in the examination for fertility in man.

Chapter 3B reports the results of S P M tests on a routine basis in the diagnosing of involuntary infertility in man. *Density* and

motility of spermatozoa in the ejaculate clearly influenced the results of tests employing normal cervical mucus from the ovulatory phase as penetration medium. The effect of spermatozoal *morphology* was less clear.

The investigation concerned 135 couples. All females showed normal cervical mucus during the ovulatory phase, but there was a broad range in the degree of fertility of the 135 ejaculates (Tables 3, 3a, 3b, 3c, 3d and 3e). Ejaculates with a spermatozoal density of less than 20 million per ml. gave significantly worse results than those with 20 million per ml. or more. Spermatozoal densities of 60 million or more per ml. gave results significantly better than densities of 20-60 million per ml. (Table 3a).

The group with a quantitative spermatozoal motility of less than 40 % yielded S P M results significantly worse than the group with 40-60 % quantitative spermatozoal motility. Where the quantitative motility was 60 % or more the results were no better than those obtained for the 40-60 % group (Table 3b).

The S P M test was also influenced by the qualitative motility of the spermatozoa. A degree of motility of more than 3 yielded a noticeable improvement of the results (Table 3c).

Less clear was the influence of *spermatozoal morphology* on the S P M test results. This was probably due to the fact that in some cases a high percentage of abnormally shaped spermatozoal heads were seen in spermatozoal populations with good density and motility. Also exogenous factors can exert an unfavourable influence on the motility of the spermatozoa in the ejaculate, while the morphology remains consistently unaltered (Table 3d).

When a *seminal fertility score* was arrived at on the basis of density, motility and morphology of the ejaculatory spermatozoa, a positive correlation existed between this score and the S P M test results (Table 3e).

The qualitative spermatozoal motility at the far end of the glass capillary appeared worse than at the near end some two hours after the beginning of the S P M test with 25 of the 135 couples taking part in the investigation (Table 3). This fact was considered to constitute an unfavourable prognosis for conception.

The S P M test results of 50 other couples were analysed (Table 4). In these subjects the fertility score for the semen was *good* but

one or more physico-chemical characteristics of the cervical mucus did not fulfil the criteria for normal cervical mucus obtained during the ovulatory phase. The analysis showed that when mucal viscosity amounted to 5.5 or more, the spermatozoa were unable to reach the far end of the glass capillary. The test results in those cases were invariably *negative, bad* or *poor*. Where the "Spinnbarkeit" of the cervical mucus was 30 mm. or less, or the fern-test was negative, the S P M test was also *negative, bad* or *poor* in all cases. An acidic cervical mucus, with a pH ranging from 6.3 to 7.0 did not influence the S P M test unfavourably. The glucose content also did not affect the S P M test results.

For 54 couples where the semen had a normal fertility score and the cervical mucus fulfilled the criteria for normal mucus from the ovulatory phase, the velocity of spermatozoal progression was examined in a medium of cervical mucus at R. T., by means of the S P M. The mean velocity was 1.8 mm. per minute, with maximal limits of 1.0 and 2.8 mm. per minute (Table 5).

The duration of spermatozoal motility of 310 men each of whom had been the father of one or more children, was determined with the aid of the S P M test after the spermatozoa had penetrated from the ejaculate into blood serum (blood group AB, Rh +) at a temperature of 37° C. With one exception the motility duration exceeded 24 hours, while in 257 cases it exceeded 48 hours.

Chapter 3C describes an investigation aimed at obtaining an estimate of the duration of the ability of spermatozoa to penetrate the cervical mucus from the intra-vaginal semen after coitus (Table 6). It appeared that after 20 minutes in the intra-vaginal lumen, spermatozoa generally remained sufficiently vital to give a *fair* or *good* result in the S P M test. After 35 minutes or longer spermatozoal motility decreased to such an extent that the test results were mostly *negative, bad* or *poor*.

This led to the conclusion that prevention of semen reflux for half an hour after coitus can encourage conception, but it seems to be of no benefit to prevent it for any longer period.

Chapter 3D describes the results of S P M tests as part of a contraceptive research project. Four different progestational compounds, i.e. norethindrone acetate, megestrol acetate, lynestrenol and Δ 5-10 lynestrenol were used.

Fifty-six fertile married women who wished to delay the next pregnancy took one of these progestational compounds by mouth in tablet form at a dosage of 0.5 mg. per day. This was intended to reduce water and salt excretion by the cervical glands to such an extent that the viscosity of the cervical mucus increased sufficiently to prevent penetration and migration of spermatozoa through the mucal column in the cervical canal. With a few exceptions norethindrone acetate, megestrol acetate and lynestrenol appeared to have the desired effect (Tables 7, 8 and 9); Δ 5-10 lynestrenol was disappointing (Table 10), as it was shown to have no progestational effect, but an estrogen-like action on the cervical glands. At an early point in time this compound was therefore eliminated from the contraceptive project. It was later used for the treatment of females with undesired sterility stemming from excessive mucous viscosity. This treatment resulted in the pregnancy of a number of the women thus treated.

Chapter 3E deals with an investigation, applying the SPM technique, into a search for *spermatozoal immobilization factors in the serum of women* with undesired sterility. For this purpose the semen reservoir was filled with the ejaculate of the partner and the glass capillary with fresh serum of the female. Among 278 couples subjected to this test, there appeared only 2 who gave positive immobilization results and 5 where the test was weakly positive. The sterility of these seven women was of an unknown aetiology. One of these women showed sperm-agglutinating antibodies in the serum (titre 1 : 512). Among 41 other couples with infertility of unknown aetiology there were 4 women with sperm-agglutinating antibodies, giving titres of respectively 1 : 128, 1 : 32, 1 : 4 and 1 : 4. The immobilization test was negative for these 41 women. Therefore this investigation indicates that the presence of *anti-spermatozoal antibodies in the female serum* is not considered to be a frequent cause of undesired sterility, in contrast to statements by a number of other workers.

Chapter 3F reports the results of investigations into the occurrence of *spermatozoal immobilizing agents in male serum*, again using the SPM technique (Tables 11, 12 and 13).

Findings showed that in the majority of men with a positive spermatozoal immobilization test, the presence of spermatozoal agglu-

tinins could be demonstrated in the blood. Only in a few cases was the one positive and the other negative, or *vice versa*.

In Chapter 3G a comparative study is made of the morphology of seminal spermatozoa and that of spermatozoa from the same semen after penetration of more than 3 cm. into cervical mucus. This was done in 23 cases, by means of an S P M test (Table 14). This resulted in the finding that spermatozoa which migrated from the semen into the cervical mucus for more than 3 cm. showed 45 % fewer head-shape abnormalities than the spermatozoa in the original semen (range 12-88 %). This would indicate that those spermatozoa which reach the upper parts of the female genital tract have been previously "selected" by the cervical mucus ("filter principle").

Chapter 4 describes comparative results of *penetration tests* according to the classical method of Miller and Kurzrok and with the S P M. This investigation was done with 52 couples. The physico-chemical characteristics of the cervical mucus specimens were partly favourable and partly unfavourable for penetration, migration and maintenance of motility of the spermatozoa. All semen samples possessed a density exceeding 20 million per ml. of ejaculate with a motility of at least 40 % grade 3. No less than 50 % of the spermatozoa had normally shaped heads. Results (Table 15) indicated that strong formation of phalanxes in the Miller-Kurzrok test was, as a rule, accompanied by high viscosity of the cervical mucus. In those cases there was little or no spermatozoal penetration in the Miller-Kurzrok test and the S P M test gave correspondingly bad results.

In 4 cases (Nos. 8, 12, 26, 41) the Miller-Kurzrok test was strongly positive but the S P M test *negative* or *bad*. In one of these cases (No. 12) there was a possible pseudo-penetration in the Miller-Kurzrok test which does not occur with the S P M test. In the three other cases (Nos. 8, 26 and 41) the discrepancy in the results of the two tests could be attributed to rapid decrease in qualitative spermatozoal motility after penetrating the cervical mucus. Such a situation can still give a strongly positive Miller-Kurzrok test result, but this will render the S P M test bad. Conversely, five cases (Nos. 17, 28, 38, 40 and 49) were observed where the results with the Miller-Kurzrok test were considerably worse than the results with the S P M test.

which may be attributable to the fact that in the Miller-Kurzrok test it is not always possible to obtain a good interface between semen and cervical mucus. It is concluded from this series of tests that the results of the two methods generally correspond fairly well, however, with a greater chance of wrong results with the Miller-Kurzrok technique than with the S P M test. In addition, the S P M test gives more information particularly concerning the migration velocity and duration of motility of the spermatozoa in the cervical mucus.

Chapter 5 compares results obtained by the Sims-Huhner test and the S P M test.

The first part of this chapter discusses two more or less opposite concepts regarding the interpretation of the results of the Sims-Huhner test.

According to the one concept, called the "filter theory", normal spermatozoa, after coitus, are thought to pass through the mucal column of the cervical canal in a short period during the ovulatory phase, provided the physico-chemical characteristics of the cervical mucus make a rapid passage of spermatozoa possible. The spermatozoa still present in the cervical mucus a few hours after coitus, are, according to this theory, regarded as inferior and unable to make their way sufficiently rapidly through the mucal column. Given a good copulatory technique, normal male and female genital anatomy, good semen and normal ovulatory cervical mucus, the "filter theory" states that in this case a negative or bad Sims-Huhner test would be favourable for conception. There has then been a massive migration of normal spermatozoa to the higher parts of the female genital tract. The presence of many good motile spermatozoa in the cervical mucus would indicate unfavourable conditions for conception, unless the Sims-Huhner test is carried out shortly after coitus.

The counterpart of the "filter theory" is the "depot theory".

This theory assumes that spermatozoa can ascend from the cervical mucus to the higher parts of the female genital tract only after ovulation. They are thought to make use of follicular liquor, running down the homolateral tube after ovulation, along the homolateral side of the uterine lumen into the mucal column within the cervical canal. This is thought to have a directional function towards

the spermatozoa in the uterine lumen. Therefore according to the "depot theory", if many good motile spermatozoa are found in the cervical mucus, prognosis for fertility is good. A negative or bad Sims-Huhner test before ovulation would indicate an unfavourable prognosis. Arguments are advanced for and against both theories.

The second part of Chapter 5 discusses the results of 160 Sims-Huhner tests carried out on 160 couples. The cervical mucus of all females satisfied the criteria for normal ovulatory cervical mucus. The fertility rating for the male semen was *sterile, bad, poor, passable* or *good*. The results (Table 16) showed a positive correlation between seminal fertility rating and the results of the Sims-Huhner test carried out in all couples 2 to 8 hours after coitus. The outcome indicates that during the ovulatory phase the cervical mucus temporarily *harbours normal spermatozoa*, and is not only a "filter" through which normal spermatozoa pass rapidly while inferior spermatozoa remain behind. This does not mean that spermatozoa can only ascend from this transient depot via the follicular liquor into the ampullar portion of the fallopian tubes until after ovulation. In fact, it is certain that also before ovulation the spermatozoa can reach the uterine fundus and the fallopian tubes.

In 22 out of 57 couples where the semen was rated as *good*, the Sims-Huhner test results were *negative, bad* or *poor* (Table 16). However, in 16 of these 22 couples the S P M test was *fair, good* or *excellent*. In 12 of these 16 couples a reason could be given for the discrepancy between the Sims-Huhner test and the S P M test results (dyspareunia, corporeal hypospadias of the penis, disturbed ejaculation, ejaculatory volume less than 1 ml., vaginal "lethal factor", continuation of coital movements after ejaculation, abnormally short penis, unfavourable coital position). The four remaining couples suggested a possibly rapid passage of spermatozoa through the mucal column in the cervical canal.

In 6 of the 22 couples reported above where the Sims-Huhner test results were much worse than would have been expected on the grounds of the examination of the semen, the Sims-Huhner test results did, however, correspond with those obtained with the S P M test. These six couples were subjected to a crossed S P M test with cervical mucus taken during the ovulatory phase of an assumedly fertile female. The results were *good* in 3 cases. In the 3 remaining

couples the results of the crossed tests corresponded to the homologous test results, suggesting that the penetration deficiency was to be found in the semen itself.

Fifteen out of 42 couples with a poor semen score gave a *fair*, *good* or *excellent* Sims-Huhner test result (Table 16). In these 15 couples, however, the S P M test results were *negative*, *bad* or *poor*. This discrepancy was due, probably, to the unfavourable effect of collection and transport of the semen. This fact was occasionally observed.

The final conclusion of Chapter 5 is that in a number of cases the *in vitro* spermatozoal penetration test, performed with the sperm penetration meter (S P M test), can yield data which form an important addition to those obtained in the *in vivo* spermatozoal penetration test (Sims-Huhner test).

samenvatting en conclusies

Het doel van de spermatozoënpeneratieproef *in vitro* (hierna *peneratieproef* genoemd) is vast te stellen of en in hoeverre spermatozoënen uit een semenspecimen in staat zijn cervixslijm of een andere vloeistof binnen te dringen, op welke wijze en met welke snelheid ze zich daarin verplaatsen en hoe lang en in welke mate de binnengedrongen spermatozoënen in het desbetreffende medium bewegelijk blijven.

De peneratieproef kan op verschillende manieren en onder verschillende omstandigheden uitgevoerd worden.

De eisen, waaraan een proef als deze moet voldoen om te kunnen worden gebruikt als routine-onderdeel van het fertiliteitsonderzoek bij de mens, zijn de volgende:

- a. De proef moet met eenvoudige en gemakkelijk te hanteren apparatuur kunnen worden uitgevoerd.
- b. De proef moet kunnen worden verricht met geringe hoeveelheden van het te onderzoeken materiaal.
- c. De resultaten van de proef moeten reproduceerbaar zijn.
- d. De peneratiedichtheid, de peneratiediepte, de migratiesnelheid en de bewegelijkheidsduur van de spermatozoënen in de desbetreffende vloeistof moeten met een redelijke nauwkeurigheid kunnen worden vastgesteld.

In Hoofdstuk 1 worden twee groepen peneratieproeven besproken, namelijk de *dekglassmethoden* en de *capillairmethoden*. De dekglassmethoden hebben het bezwaar, dat de spermatozoënen zich hierbij na de peneratie in alle richtingen en niet recht-

lijng in het penetratiemedium verplaatsen. Hierdoor is er geen verband tussen de penetratiediepte en de afstand die de spermatozoën in het penetratiemedium hebben afgelegd. Ook kan bij de dekglasmethoden door het steeds wisselen van bewegingsrichting van de spermatozoën, de migratiesnelheid moeilijk worden vastgesteld. Ten slotte zijn de dekglasmethoden in het algemeen niet geschikt om de beweeglijkheidsduur van de spermatozoën in het penetratiemedium bij een omgevingstemperatuur van 37° C vast te stellen als gevolg van indroging van het materiaal. Met de capillairmethoden kunnen de penetratiedichtheid, de penetratiediepte, de migratiesnelheid en de motiliteitsduur van de spermatozoën in het desbetreffende medium worden bepaald. De capillairmethoden die in de literatuur zijn beschreven, zijn echter te ingewikkeld of geven niet voldoende betrouwbare resultaten om te kunnen worden gebruikt als routineonderdeel van het vruchtbaarheidsonderzoek bij de mens.

Er werd daarom een eenvoudig apparaat geconstrueerd, dat wel aan de gestelde eisen bleek te voldoen. Dit apparaat werd *spermatozoënpenetratiemeter* genoemd (hierna aangeduid als S P M).

In Hoofdstuk 2 wordt allereerst een beschrijving gegeven van de eenvoudige en goedkope wijze waarop een S P M kan worden geconstrueerd. In elke instrumentenwerkplaats waar een glaszaag aanwezig is, kan het apparaat tegen de kostprijs van slechts enkele guldens binnen de tijd van een uur worden gemaakt.

Vervolgens wordt beschreven op welke wijze de materialen, nodig voor de uitvoering van de spermatozoënpenetratieproef *in vitro* met behulp van de spermatozoënpenetratiemeter in het kader van het vruchtbaarheidsonderzoek bij de mens, werden verkregen en hoe het transport, het onderzoek en de bewaring van deze materialen vóór het inzetten van de proef plaats vond.

Voor de verkrijging van het semen werd aan de betrokken man een instructieformulier en transportmateriaal verstrekt. Wanneer als penetratiemedium cervixslijm werd gebruikt, werd dit met een speciaal voor dit doel ontworpen tang uit het cervicaalkanaal genomen, op een objectglas gedeponneerd en daarna tot het inzetten van de proef bewaard in een vochtige petri-schaal. Wanneer het cervixslijm langer in depot werd gehouden, werd het opgezogen in glas-capillairen, die aan weerszijden met boetseerwas werden afgesloten

en in een voor dit doel speciaal geconstrueerde houder in de ijskast bewaard. Werd bloedserum gebruikt als penetratiemedium, dan werd dit verkregen door venapunctie en centrifugeren van het bloed. Zo nodig werd het serum in diepgevroren toestand bewaard.

Op grond van de dichtheid, de kwantitatieve bewegelijkheid, de kwalitatieve bewegelijkheid en de morfologie van de spermatozoën in het ejaculaat, werd van elk ejaculaat een „fertiliteitsgraad” berekend. Dit gebeurde op basis van een puntenwaardering.

Van het cervixslijm werden de *helderheid*, de *viscositeit*, de „*Spinnbaarheid*”, de *zuurgraad*, het *glucosegehalte* en het vermogen tot uitkristallisering in de vorm van een *varenstructuur* bepaald. De helderheid werd in graden uitgedrukt. Voor de bepaling van de viscositeit werd gebruik gemaakt van de viscositeitsmeter volgens Scott Blair. De „Spinnbaarheid” werd gemeten met een zelf ontworpen methode. De bepaling van de zuurgraad en van het glucosegehalte vonden plaats met reagenspapier. Voor het verrichten van de varentest werd het cervixslijm op een objectglas gedroogd.

In het laatste deel van Hoofdstuk 2 wordt de uitvoering van de spermatozoënpenetratieproef *in vitro* met behulp van de spermatozoënpenetratiemeter (hierna SPM-proef genoemd) uitvoerig beschreven. Vóór het inzetten van de test werden aan het ejaculaat per cc. 500 E penicilline en 0,5 mg. neomycine toegevoegd om bacteriegroei te voorkomen.

Hoofdstuk 3 beschrijft de resultaten van de SPM-proef.

In het eerste deel van dit hoofdstuk (deel A) zijn de resultaten vermeld van enkele onderzoeken betreffende de bruikbaarheid van de proef als onderdeel van het vruchtbaarheidsonderzoek bij de mens.

Uit de resultaten van deze onderzoeken konden de volgende conclusies worden getrokken:

- a. Passieve overgang van spermatozoën vanuit het met semen gevulde semenreservoir in het met cervixslijm gevulde glascapillair vindt niet plaats.
- b. Passieve overgang van spermatozoën vanuit het met semen gevulde semenreservoir in het met bloedserum gevulde glascapillair kan worden verhinderd door de SPM steeds in horizontale stand te houden en voorzichtig te verplaatsen.

- c. De omgevingstemperatuur is van invloed op het resultaat van de S P M-proef. De penetratiedichtheid en de migratiesnelheid van spermatozoën in bloedserum is bij 40° C en bij 37° C beter dan bij kamertemperatuur, terwijl de bewegelijkheidsduur bij 40° C korter is dan bij 37° C en bij 37° C korter dan bij kamertemperatuur (Tabel 1).
- d. Wanneer menselijk bloedserum wordt gebruikt als penetratiemedium, zijn de resultaten van de S P M-proef beter dan bij gebruikmaking van een isotonische glucose-zoutoplossing, een colloidaal plasmasubstituut of een gepasteuriseerde oplossing van menselijk plasma-eiwit (Tabel 2).
- e. Het bewaren van bloedserum in diepgevroren toestand heeft geen invloed op het resultaat van de S P M-proef wanneer dit diepgevroren bloedserum na ontdooiing wordt gebruikt als penetratiemedium.
- f. De resultaten van de S P M-proef zijn voldoende reproduceerbaar om deze test als onderdeel van het vruchtbaarheidsonderzoek bij de mens te gebruiken.

In het tweede deel van Hoofdstuk 3 (deel B) worden de resultaten van het onderzoek met de S P M-proef als routine-onderdeel van het onderzoek naar de oorzaken van ongewilde steriliteit bij de mens vermeld.

Bij gebruik van normaal cervixslijm uit de ovulatieperiode als penetratiemedium, bleken de *dichtheid* en de *motiliteit* van de spermatozoën in het ejaculaat een duidelijke invloed te hebben op het resultaat van de proef. De invloed van de *morfologie* der spermatozoën was minder duidelijk.

Het onderzoek betrof 135 verschillende echtparen. Bij al de vrouwen was het cervixslijm tijdens de ovulatiefase normaal; de 135 ejaculaten verschilden sterk in „fertiliteitsgraad” (Tabel 3, 3a, 3b, 3c, 3d en 3e).

Bij de groep ejaculaten met een *spermatozoëndichtheid* kleiner dan 20 miljoen per cc ejaculaat was het resultaat significant slechter dan in de groep ejaculaten met een spermatozoëndichtheid van 20 miljoen of meer per cc ejaculaat. Bij de groep ejaculaten met een spermatozoëndichtheid van 60 miljoen of meer per cc ejaculaat was het resultaat significant beter dan bij een spermatozoëndichtheid van 20-60 miljoen per cc (Tabel 3a).

Bij de groep ejaculaten met een *kwantitatieve spermatozoën-motiliteit* in het ejaculaat minder dan 40 % was het resultaat significant slechter dan bij de groep ejaculaten waar de kwantitatieve spermatozoën-motiliteit 40-60 % bedroeg. De groep ejaculaten met een kwantitatieve motiliteit van de spermatozoën van 60 % of meer gaf geen betere uitslag dan de groep met een kwantitatieve motiliteit van 40-60 % (Tabel 3b).

De *kwalitatieve bewegelijkheid van de spermatozoën* bleek het resultaat van de S P M-proef eveneens te beïnvloeden. Vooral na het bereiken van motiliteitsgraad 3 werd een opvallende verbetering in de uitslag waargenomen (Tabel 3c).

De invloed van de *morfologie van de spermatozoën* op de uitslag van de S P M-proef was minder duidelijk dan de invloed van de dichtheid en de motiliteit. Dit is waarschijnlijk toe te schrijven aan het feit, dat in sommige gevallen een hoog percentage abnormale kopvormen kan worden aangetroffen in een spermatozoënpopulatie met een goede dichtheid en een goede bewegelijkheid. Ook kunnen exogene factoren de motiliteit van de spermatozoën in het ejaculaat ongunstig beïnvloeden, terwijl de morfologie daarbij altijd onveranderd blijft (Tabel 3d).

Wanneer op grond van de dichtheid, de motiliteit en de morfologie van de spermatozoën in het ejaculaat een fertiliteitsbeoordeling van het semen plaats vond, bleek er een sterke correlatie te bestaan tussen de uitslag van deze fertiliteitsbeoordeling en de uitslag van de S P M-proef (Tabel 3e).

Bij 25 van bovengenoemde 135 echtparen bleek dat in de S P M-proef 2 uren na het begin van de test de kwalitatieve bewegelijkheid van de spermatozoën aan het einde van het glascapillair slechter was dan aan het begin (Tabel 3). Dit werd als een ongunstig teken beschouwd met betrekking tot de kans op conceptie.

In Tabel 4 worden de resultaten weergegeven van de S P M-proef bij 50 verschillende echtparen, waar de fertiliteitsgraad van het semen als goed (good) werd gekwalificeerd doch waarbij één of meer fysico-chemische eigenschappen van het cervixslijm niet voldeden aan de criteria voor normaal cervixslijm uit de ovulatiefase. Uit dit onderzoek bleek, dat wanneer de viscositeit van het cervixslijm 5,5 of meer bedroeg, het eindpunt van het glascapillair door de spermatozoën niet werd bereikt. Het resultaat van de

proef was dan altijd *negatief, slecht* (bad) of *vrij slecht* (poor). Was de „Spinnbaarheid” van het cervixslijm 30 mm. of minder of was de varentest negatief, dan was de uitslag eveneens in alle gevallen *negatief, slecht* (bad) of *vrij slecht* (poor). Een zure reactie van het cervixslijm, waarbij de pH varieerde van 6,3-7, had geen ongunstige invloed op de uitslag van de S P M-proef. Het glucosegehalte van het cervixslijm bleek het resultaat van de S P M-proef evenmin te beïnvloeden.

Bij 54 verschillende echtparen, waar het semen als normaal fertiel kon worden beschouwd en waar het cervixslijm voldeed aan de criteria voor normaal cervixslijm uit de ovulatieperiode, werd met de S P M-proef bij kamertemperatuur de voortbewegingssnelheid van spermatozoën in cervixslijm onderzocht. Er werd een gemiddelde snelheid gevonden van 1,8 mm. per minuut, met een spreidingsbreedte van 1-2,8 mm. (Tabel 5).

Bij 310 mannen met één of meer kinderen werd de S P M-proef gebruikt voor een onderzoek naar de motiliteitsduur van hun spermatozoën, nadat deze uit het ejaculaat in bloedserum (bloedgroep AB Rh +) waren gepenetreerd bij een temperatuur van 37° C. Uit dit onderzoek bleek dat de motiliteitsduur van de spermatozoën onder genoemde omstandigheden op één uitzondering na meer dan 24 uur bedroeg. In 257 gevallen bedroeg de motiliteitsduur van de spermatozoën in het bloedserum minstens 48 uren.

In het derde deel van Hoofdstuk 3 (deel C) is een onderzoek beschreven waarvan het doel was een indruk te krijgen aangaande de tijd gedurende welke spermatozoën na de coitus nog in staat zijn om vanuit het intravaginale semen het cervixslijm binnen te dringen (Tabel 6). Uit dit onderzoek bleek, dat na een intravaginaal verblijf van 20 minuten de spermatozoën in het algemeen nog voldoende vitaal waren om de uitslag van de S P M-proef *redelijke* (fair) of *goed* (good) te doen zijn. Een verblijf in de vagina van 35 minuten of langer deed de motiliteit van de spermatozoën echter zodanig afnemen, dat in het merendeel der gevallen de uitslag van deze proef *negatief, slecht* (bad) of *vrij slecht* (poor) was. De conclusie uit dit onderzoek is dat het verhinderen van semenreflux uit de vagina gedurende een half uur na de coitus de kans op conceptie kan bevorderen. Het lijkt echter niet zinvol om deze semenreflux langer dan een half uur te voorkomen.

In het vierde deel van Hoofdstuk 3 (deel D) worden de resultaten beschreven van een onderzoek met de SPM-proef als onderdeel van een anticonceptie research project. Hierbij werd gebruik gemaakt van vier verschillende progestatieve stoffen, namelijk *norethindronacetaat*, *megestrolacetaat*, *lynestrenol* en *Δ 5-10 lynestrenol*. 56 Fertiele, gehuwde vrouwen, die voorlopig niet weer zwanger wensten te worden, gebruikten groepsgewijs één van bovengenoemde progestativa, in een dosering van 0,5 mg. per dag, als een oraal ingenomen tablet. De bedoeling was om op deze wijze de water- en zoutafgifte door de cervixklieren zodanig te beperken, dat de viscositeit van het cervixslijm voldoende groot werd om penetratie en migratie van spermatozoën in en dóór het cervixslijm zodanig te bemoeilijken, dat geen spermatozoënpassage door de slijmkolom in het cervicaalkanaal zou plaats vinden. Norethindronacetaat, megestrolacetaat en lynestrenol bleken op een enkele uitzondering na aan deze eis te voldoen (Tabel 7, 8 en 9); Δ 5-10 lynestrenol stelde echter teleur (Tabel 10). Het bleek geen progestatieve doch daarentegen een oestrogene invloed op de cervixklieren te hebben, en werd daarom spoedig uit het anticonceptie research project genomen. Later werd het gebruikt voor de behandeling van vrouwen met ongewenste steriliteit als gevolg van taai cervixslijm. Bij een aantal van de op deze wijze behandelde vrouwen trad zwangerschap op.

In het vijfde deel van Hoofdstuk 3 (deel E) wordt een onderzoek beschreven, waarbij de SPM-proef gebruikt werd voor het opsporen van *spermatozoënimobiliserende stoffen in het bloedserum van vrouwen* met ongewenste steriliteit. Het semenreservoir werd daartoe gevuld met het ejaculaat van de echtgenoot; het glascapillair met vers bloedserum van de echtgenote. Van 278 onderzochte echtparen bleken er slechts 2 te zijn waar de op deze wijze uitgevoerde spermatozoënimobilisatieproef *positief* was, terwijl de uitslag vijf keer *zwak positief* uitviel. Bij deze zeven vrouwen bestond onbegrepen steriliteit. Bij één van hen werden tegen spermatozoën gerichte agglutininen in het bloedserum aangetoond (titer 1 : 512). Bij de zes andere vrouwen was de spermatozoëntagglutinatieproef negatief. Bij 41 andere echtparen met onbegrepen steriliteit werd bij de vrouw 4 keer een positieve spermatozoëntagglutinatieproef gevonden, met een titer van resp. 1 : 128,

1 : 32, 1 : 4 en 1 : 4. De spermatozoënimobilisatieproef was bij deze 41 vrouwen negatief. Bovengenoemd onderzoek wijst er niet op, dat de aanwezigheid van tegen spermatozoën gerichte immuun-antilichamen in het bloedserum van de vrouw een veel voorkomende oorzaak is van ongewilde steriliteit, zoals door sommige onderzoekers wordt verondersteld.

Het zesde deel van Hoofdstuk 3 (deel F) geeft de resultaten weer van een onderzoek naar de aanwezigheid van *spermatozoënimobiliserende stoffen in het bloedserum van de man*, met gebruikmaking van de S P M-proef. (Tabel 11, 12 en 13). Uit dit onderzoek bleek, dat bij de meeste mannen waar de spermatozoënimobilisatieproef positief was, spermatozoënnagglutinenen in het bloed konden worden aangetoond. Slechts in enkele gevallen was de spermatozoënimobilisatieproef positief en de spermatozoënnagglutinatiesproef negatief of omgekeerd.

In het laatste deel van Hoofdstuk 3 (deel G) wordt van 23 gevallen een vergelijkend onderzoek beschreven betreffende de morfologie van de spermatozoën in het semen en de morfologie van de spermatozoën die vanuit dit semen meer dan 3 cm. diep in cervixslijm waren gepenetreerd tijdens de S P M-proef (Tabel 14).

Uit de resultaten van dit onderzoek bleek dat van de spermatozoën, die uit het semen verder dan 3 cm in het cervixslijm van het glascapillair waren gemigreerd, het percentage abnormale kopvormen met gemiddeld 45 % was verminderd (spreidingsbreedte 12-88 %). Dit wijst er op, dat spermatozoën die de hoger gelegen delen van de tractus genitalis van de vrouw bereiken, vooraf door het cervixslijm zijn „geselecteerd” („filterprincipe”).

In Hoofdstuk 4 wordt een vergelijkend onderzoek beschreven betreffende de resultaten van de penetratieproef volgens de klassieke methode van Miller en Kurzrok en volgens de methode met de S P M. Dit onderzoek werd verricht bij 52 verschillende echtparen. De fysico-chemische eigenschappen van de gebruikte cervixslijmspecimina waren voor een deel gunstig en voor een deel ongunstig voor de penetratie, de migratie en de handhaving van de bewegelijkheid der spermatozoën. De ejaculaten hadden alle een spermatozoëndichtheid van minstens 20 miljoen per cc., terwijl de motiliteit der sper-

matozoën minstens 40 % gr. 3 bedroeg. Minstens 50 % der spermatozoën bezat de normale kopvorm.

Uit dit onderzoek (Tabel 15) bleek, dat een sterke phalanxvorming in de Miller-Kurzrokproef als regel gepaard ging met een hoge viscositeit van het cervixslijm. Er was dan geen of weinig spermatozoënpenertratie in de Miller-Kurzrokproef zelf; de S P M-proef gaf een overeenkomstig slecht resultaat.

In 4 gevallen (8, 12, 26 en 41) was de Miller-Kurzrokproef *sterk positief*, doch de uitslag van de S P M-proef *negatief* of *slecht* (bad). In één van deze gevallen (12) moet worden gerekend met de mogelijkheid van pseudo-penertratie in de Miller-Kurzrokproef. Deze pseudo-penertratie is in de S P M-proef niet mogelijk. In de drie andere gevallen (8, 26 en 41) is de discrepantie tussen de uitslag van de beide proeven veroorzaakt door de snelle afname van de kwalitatieve motiliteit van de spermatozoën, na de penertratie in het cervixslijm. Dit kan nog wel met een sterk positieve Miller-Kurzrokproef gepaard gaan, doch het resultaat van de S P M-proef wordt daardoor *slecht* (bad).

Omgekeerd waren er vijf gevallen (17, 28, 38, 40 en 49) waar het resultaat van de penertratieproef volgens de methode van Miller-Kurzrok veel slechter was dan bij gebruikmaking van de S P M-proef. Dit is mogelijk toe te schrijven aan het feit, dat het niet altijd gelukt om bij de Miller-Kurzrokproef een goed grensvlak te krijgen tussen semen en cervixslijm.

De conclusie uit dit onderzoek is, dat de resultaten van de Miller-Kurzrokproef en van de S P M-proef in het algemeen vrij goed met elkaar overeenkomen. Bij de Miller-Kurzrokproef is de kans op een foutieve uitslag echter groter dan bij de S P M-proef. Bovendien geeft de S P M-proef meer informatie dan de Miller-Kurzrokproef, met name wat betreft de migratiesnelheid en de bewegelijkheidsduur van de spermatozoën in het cervixslijm.

Hoofdstuk 5 geeft een vergelijkend onderzoek betreffende de resultaten van de Sims-Huhnerproef en van de S P M-proef.

In het eerste deel van Hoofdstuk 5 worden twee min of meer tegengestelde opvattingen over de beoordeling van de Sims-Huhnerproef besproken.

Volgens de ene opvatting, aangeduid als de „filtertheorie”, zou-

den normale spermatozoën na de coitus tijdens de ovulatiefase de slijmkolom in het cervicaalkanaal in korte tijd passeren, mits de fysico-chemische kwaliteiten van het cervixslijm een vlotte spermatozoënpassage mogelijk maken. De spermatozoën, die enkele uren na de coitus nog in het cervixslijm aanwezig zijn, moeten volgens deze theorie beschouwd worden als minderwaardige spermatozoën, die de slijmkolom niet voldoende snel kunnen passeren. Bij een goede coitus techniek, een normale anatomie van het mannelijk en vrouwelijk genitaalapparaat, goed semen en normaal ovulatiecervixslijm is volgens de „filtertheorie” een negatieve of slechte Sims-Huhnerproef gunstig voor de kans op conceptie. Er zijn dan veel normale spermatozoën naar de hogere delen van de vrouwelijke tractus genitalis gemigreerd. De aanwezigheid van veel goed bewegelijke spermatozoën in het cervixslijm is daarentegen ongunstig voor de kans op conceptie, tenzij de Sims-Huhnerproef korte tijd na de coitus is verricht.

De tegenhanger van de „filtertheorie” is de „depottheorie”. Deze gaat er van uit, dat spermatozoën pas na de ovulatie vanuit het cervixslijm naar de hogere delen van de vrouwelijke tractus genitalis kunnen ascenderen. Ze zouden hierbij gebruik maken van het follikelvocht, dat na de ovulatie door de homolaterale tuba langs de homolaterale zijkant van het cavum uteri naar de slijmkolom in het cervicaalkanaal zou stromen. Hierdoor zou het „verdwalen” van de spermatozoën in het cavum uteri worden voorkomen. Volgens de „depottheorie” zou een Sims-Huhnerproef, waarbij vóór de ovulatie veel goed bewegelijke spermatozoën in het cervixslijm worden gevonden, gunstig zijn voor de fertiliteitsprognose. Wanneer vóór de ovulatie de uitslag van de Sims-Huhnerproef echter negatief of slecht is, zou dit voor de fertiliteitsprognose ongunstig zijn.

Er worden een aantal argumenten vóór en tegen beide theorieën naar voren gebracht.

In het tweede deel van Hoofdstuk V worden de resultaten besproken van 160 Sims-Huhnerproeven, uitgevoerd bij 160 verschillende echtparen. Het cervixslijm van de desbetreffende vrouwen voldeed in alle gevallen aan de criteria voor normaal cervixslijm uit de ovulatiefase. De fertiliteitsbeoordeling van het semen der mannen was *steriel*, *slecht* (bad), *vrij slecht* (poor), *voldoende* (passable) of

goed (good). Uit dit onderzoek (Tabel 16) bleek, dat er een positieve correlatie bestond tussen de fertiliteitsbeoordeling van het semen en het resultaat van de Sims-Huhnerproef, welke bij alle echtparen 2-8 uur na de coitus was verricht. Dit resultaat pleit er voor, dat tijdens de ovulatieperiode het cervixslijm ook een *tijdelijke verblijfplaats is voor normale spermatozoën* en niet alleen een „filter” die „minderwaardige” spermatozoën tegenhoudt en normale spermatozoën doorlaat. Dit betekent niet, dat pas na de ovulatie de normale spermatozoën vanuit deze tijdelijke verblijfplaats via het follikelvocht opstijgen naar de pars ampullaris tubae. Het is wel zeker, dat ook vóór de ovulatie spermatozoën vanuit het cervixslijm de fundus uteri en de tubae kunnen bereiken.

Bij 22 van 57 echtparen, waar het semen van de man als *goed* (good) was gekwalificeerd, was de uitslag van de Sims-Huhnerproef *negatief, zeer slecht* (bad) of *slecht* (poor) (Tabel 16). Bij 16 van deze 22 echtparen was de uitslag van de S P M-proef echter *vrij goed* (fair), *goed* (good) of *zeer goed* (excellent). Bij 12 van deze 16 echtparen kon een verklaring voor de discrepantie tussen de uitslag van de Sims-Huhnerproef en de uitslag van de S P M-proef worden gevonden (dyspareunie, corporele hypospadië van de penis, gestoorde ejaculatie, ejaculaatvolume kleiner dan 1 cc., „letale factor” in de vagina, continuering van de coitusbewegingen na de ejaculatie, abnormaal korte penis, ongunstige houding bij de coitus). Bij de vier overige echtparen moet worden gerekend met de mogelijkheid van een snelle spermatozoënpassage door de slijmkolom in het cervicaalkanaal.

Bij 6 van de 22 bovengenoemde echtparen, waar de uitslag van de Sims-Huhnerproef veel slechter was dan op grond van de semenanalyse zou mogen worden verwacht, kwam de uitslag van de S P M-proef met die van de Sims-Huhnerproef overeen. Bij 3 van deze 6 echtparen gaf de gekruiste S P M-proef, waarbij gebruik werd gemaakt van cervixslijm uit de ovulatieperiode van een vermoedelijk fertiele vrouw, een goed resultaat. Bij de 3 overige echtparen kwam het resultaat van deze gekruiste S P M-proef overeen met dat van de homologe S P M-proef, zodat de oorzaak van de penetratiestoornis in het semen moest worden gezocht.

Bij 15 van 42 echtparen, waar het semen van de man als *vrij slecht* (poor) was gekwalificeerd, was de uitslag van de Sims-

Huhnerproef desondanks *vrij goed* (fair), *goed* (good) of *zeer goed* (excellent) (Tabel 16). De S P M-proef was echter bij deze 15 echtparen *negatief*, *zeer slecht* (bad) of *slecht* (poor). Deze discrepantie is waarschijnlijk het gevolg geweest van de slechte invloed, die het opvangen en het transport van het semen soms kan hebben op het penetratievermogen van de spermatozoën.

De slotconclusie van Hoofdstuk 5 is, dat de spermatozoënpeneratieproef *in vitro*, uitgevoerd met de spermatozoënpeneratiemeter (S P M-proef) in een aantal gevallen gegevens kan verstrekken, die een belangrijke aanvulling kunnen betekenen op de informatie welke door de spermatozoënpeneratieproef *in vivo* (Sims-Huhnerproef) wordt verstrekt.

résumé et conclusions

Le but de l'épreuve de pénétration des spermatozoïdes *in vitro* (nommé ensuite *test de pénétration*) est d'établir si, et dans quelle mesure, les spermatozoïdes d'un échantillon de sperme déterminé sont à même de pénétrer dans la glaire cervicale ou dans un autre liquide; de quelle manière et à quelle vitesse ils se déplacent dans ce milieu; dans quelle mesure et pendant combien de temps ils y conservent leur motilité.

Le test de pénétration peut être exécutée de diverses manières et dans diverses conditions. Les exigences auxquelles elle doit répondre pour pouvoir être utilisée comme mesure usuelle dans l'examen de la fertilité humaine, sont les suivantes:

- a. L'épreuve doit pouvoir être exécutée au moyen d'appareils simples et faciles à manier.
- b. L'épreuve doit pouvoir être exécutée avec de faibles quantités de matériel à examiner.
- c. Les résultats de l'épreuve doivent être reproductibles.
- d. La densité spermatique et la profondeur de pénétration, la vitesse de migration et la durée de la motilité des spermatozoïdes dans le liquide en question doivent pouvoir être établies avec une précision raisonnable.

Au chapitre 1, deux groupes de tests de pénétration sont discutés; à savoir les *méthodes sur lame* et les *méthodes capillaires*. La méthode sur lame présente l'inconvénient qu'une fois que les spermatozoïdes ont pénétré dans le liquide qui leur sert de milieu, ils se déplacent dans toutes les directions sans suivre de ligne droite. De

cette façon, il n'y a pas de rapport entre la profondeur de pénétration et la distance que les spermatozoïdes ont parcourues dans le milieu de pénétration. Il est également très difficile - dans les méthodes sur lame - d'établir la vitesse de migration, par suite du changement constant de direction des spermatozoïdes. Enfin, en raison d'un dessèchement du matériel utilisé, en général les méthodes sur lame ne sont pas adéquates pour déterminer la durée de la motilité des spermatozoïdes dans le milieu de pénétration, à une température ambiante de 37° C. Les méthodes capillaires permettent d'établir la densité spermatique et la profondeur de pénétration, la vitesse de migration et la durée de la motilité des spermatozoïdes dans le milieu utilisé. Les méthodes capillaires qui ont été décrites dans la littérature, sont cependant trop compliquées ou ne donnent pas de résultats assez sûrs pour pouvoir être utilisées pour les examens usuels, faisant partie de l'étude de la fertilité humaine.

C'est pourquoi nous avons construit un appareil simple dont il est apparu qu'il répondait aux exigences posées. Nous avons nommé cet appareil *mètre de la pénétration des spermatozoïdes* (nommé ensuite M P S).

Le chapitre 2 commence par donner une description de la façon simple et peu coûteuse dont fut construit le M P S. Dans tout atelier, installé pour la fabrication d'instruments et possédant une scie à verre, l'appareil peut être fabriqué pour quelques florins et en moins d'une heure.

Ensuite il est décrit de quelle manière ont été obtenus les matériaux, nécessaires à l'exécution du test de pénétration, au moyen du M P S et dans le cadre de l'étude de la fertilité humaine. Il est enfin expliqué comment se firent le transport, l'examen et la conservation de ces matériaux avant l'exécution du test.

Pour l'obtention du sperme, l'homme en question recevait un formulaire avec des instructions écrites et le nécessaire pour le transport du matériel. Quand le milieu de pénétration était de la glaire cervicale, celle-ci était prélevée dans le canal cervical au moyen d'une pince spécialement conçue à cette fin. Elle était déposée sur un porte-objet, et ensuite conservée dans une boîte de Petri humide jusqu'au moment de l'épreuve. Quand la glaire cervicale devait être conservée pendant plus longtemps, elle était aspirée dans des tubes capillaires qui étaient ensuite bouchés des deux côtés avec de la

cire molle et conservés dans le réfrigérateur, dans un support spécialement construit à cette fin. Si le milieu de pénétration utilisé était du sérum sanguin, celui-ci était obtenu en centrifugeant du sang provenant d'une ponction veineuse. Si nécessaire, le sérum était conservé à l'état surgelé.

Un „degré de fertilité” de chaque éjaculat était calculé d'après la densité, la motilité quantitative et qualitative et la forme des spermatozoïdes dans l'éjaculat. Cette évaluation était traduite par des notes chiffrées.

La *limpidité*, la *viscosité*, la *filance*, le *degré d'acidité*, le *taux de glucose* et le pouvoir de cristallisation „*en feuille de fougère*” de la glaire cervicale étaient déterminés. La limpidité de la glaire cervicale était exprimée en degrés. Sa viscosité était déterminée au moyen d'un viscosimètre de Scott Blair. Le degré de filance était mesuré au moyen d'une méthode conçue par nous-même. Le degré d'acidité et le taux de glucose étaient déterminés au moyen d'un papier réactif. Pour l'exécution du test de cristallisation de la glaire cervicale, celle-ci était séchée sur un porte-objet.

Dans la dernière partie du chapitre 2, l'exécution du test de pénétration à l'aide du MPS (nommé ensuite *test de MPS*) est surabondamment décrite. Pour éviter la croissance de bactéries, l'éjaculat était additionné de 500 unités de pénicilline et de 0,5 mg de néomycine par cm³.

Le chapitre 3 décrit les résultats du test de MPS.

Dans la première partie de ce chapitre (partie A) sont mentionnés les résultats de quelques recherches concernant la valeur pratique de l'épreuve en tant qu'élément de l'étude de la fertilité chez l'Homme. Les résultats de ces recherches ont permis de tirer les conclusions suivantes:

- a. Il ne se produit pas de passage passif de spermatozoïdes du réservoir rempli de sperme au tube capillaire, rempli de glaire cervicale.
- b. Le passage passif de spermatozoïdes du réservoir rempli de sperme au tube capillaire, rempli de sérum sanguin, peut être empêché en maintenant toujours le MPS en une position horizontale, et en ne le déplaçant qu'avec prudence.
- c. La température ambiante exerce une influence sur le résultat du test de MPS. La densité et la vitesse de migration des sperma-

tozoïdes dans le sérum sanguin sont meilleures à des températures de 40° C et de 37° C qu'à la température de laboratoire, tandis que la motilité persiste moins longtemps à 40° C qu'à 37° C, et moins longtemps à 37° C qu'à une température de laboratoire (Tableau 1).

- d. Si le liquide de pénétration utilisé dans le M P S est du sérum sanguin, les résultats du test sont meilleurs que si l' on utilise une solution isotonique glucosée de chlorure de sodium, un substitut colloïdal du plasma ou une solution pasteurisée de protéine plasmatique humaine (Tableau 2).
- e. La conservation du sérum sanguin à l'état surgelé n'a pas d'influence sur les résultats du test de M P S, si ce sérum sanguin surgelé est utilisé comme milieu de pénétration après avoir été dégelé.
- f. Les résultats du test de M P S sont suffisamment reproductibles pour que ce test puisse être utilisé dans l'étude de la fertilité humaine.

Dans la deuxième partie du chapitre 3 (partie B) sont mentionnés les résultats de recherches au moyen du M P S, faites comme mesure usuelle dans l'étude des causes de la stérilité involontaire chez l'Homme.

Il apparut que la *densité* et la *motilité* des spermatozoïdes dans l'éjaculat, exerçaient une influence manifeste sur le résultat de l'épreuve quand le milieu de pénétration utilisé était de la glaire cervicale normale prélevée en période ovulatoire. L'influence de la *forme* des spermatozoïdes était moins nette.

Les recherches portèrent sur 135 couples différents. Chez toutes les femmes, la glaire cervicale était normale pendant la phase ovulatoire; chez les hommes, il y avait de grandes différences entre les degrés de fertilité des 135 éjaculats, (tableaux 3, 3a, 3b, 3c, 3d et 3e).

Une comparaison entre les éjaculats dans lesquels la *densité des spermatozoïdes* était inférieure à 20 millions par cm³ et ceux dans lesquels la densité était supérieure à 20 millions par cm³, démontra que le résultat était significativement plus mauvais dans le premier groupe. Dans le groupe d'éjaculats ayant une densité de spermatozoïdes de 60 millions ou davantage par cm³, les résultats furent significativement supérieurs à ceux qui furent observés dans le

groupe ayant une densité de spermatozoïdes de 20 à 60 millions par cm^3 (Tableau 3a).

Dans le groupe d'éjaculats dont les spermatozoïdes avaient une *motilité quantitative* inférieure à 40 %, le résultat de l'épreuve de pénétration des spermatozoïdes *in vitro* fut significativement plus mauvais que dans le groupe d'éjaculats ayant une motilité quantitative des spermatozoïdes de 40 à 60 %. Le groupe d'éjaculats ayant une motilité quantitative des spermatozoïdes de 60 % ou davantage ne donna pas de meilleurs résultats que celui qui avait une motilité quantitative de 40 à 60 % (Tableau 3b).

Il apparut que la *motilité qualitative des spermatozoïdes* influençait également le résultat du test de M P S. On observa surtout une amélioration remarquable du résultat, une fois que le degré de motilité 3 avait été atteint (Tableau 3c).

L'influence de la *forme des spermatozoïdes* sur le résultat du test de M P S était moins nette que l'influence de la densité et de la motilité des spermatozoïdes. Il faut probablement attribuer cela au fait qu'en peut trouver dans certains cas un pourcentage élevé de spermatozoïdes à tête anormale dans une population de spermatozoïdes d'une bonne densité et d'une bonne motilité. Des facteurs exogènes peuvent également exercer une influence défavorable sur les spermatozoïdes de l'éjaculat, alors qu'en ces cas la forme des spermatozoïdes ne se modifie jamais (Tableau 3d).

Quand on procédait à une évaluation du pouvoir fécondant du sperme d'après la densité, la motilité et la forme des spermatozoïdes de l'éjaculat, on découvrait une corrélation marquée entre le résultat de cette évaluation et le résultat du test de M P S (Tableau 3e).

Chez 25 couples sur les 135 mentionnés ci-dessus, il est apparu dans le test de M P S, que, deux heures après le début de l'épreuve, la motilité qualitative des spermatozoïdes était moins bonne au bout du tube capillaire qu'au début (Tableau 3). Ceci fut considéré comme un signe défavorable en ce qui concerne les chances d'obtenir une conception.

Le tableau 4 représente les résultats du test de M P S chez 50 couples différents dont le sperme avait un pouvoir fécondant qualifié de *bon* (good), tandis qu'un ou plusieurs caractères physico-chimiques de la glaire cervicale ne répondaient pas aux critères en vigueur pour une glaire cervicale normale en période ovulatoire.

Ces recherches démontrèrent que les spermatozoïdes n'atteignaient pas le bout du tube capillaire quand la viscosité de la glaire cervicale était de 5,5 ou davantage. Le résultat de l'épreuve était alors toujours *négatif, mauvais* (bad) ou *assez mauvais* (poor). Quand la filance de la glaire cervicale était égale ou inférieure à 30 mm ou quand le test de cristallisation de la glaire cervicale était négatif, le résultat du test de M P S était également *négatif, mauvais* (bad) ou *assez mauvais* (poor) dans tous les cas. Une réaction acide de la glaire cervicale avec un pH variant de 6,3 à 7, n'exerçait pas d'influence défavorable sur le résultat du test de M P S. Il apparut que le taux de glucose n'exerçait pas d'influence sur le résultat de l'épreuve.

Chez 54 couples différents qui pouvaient être considérés comme ayant un sperme à pouvoir fécondant normal et chez lesquels la glaire cervicale répondait aux critères d'une glaire cervicale normale en période d'ovulation, la vitesse de migration des spermatozoïdes dans la glaire cervicale fut étudiée à une température de laboratoire, au moyen du M P S. On trouva une vitesse moyenne de 1,8 mm par minute, avec un intervalle de variation de 1 à 2,8 mm. (Tableau 5).

La durée de la motilité des spermatozoïdes fut étudiée au moyen du M P S chez 310 hommes ayant un enfant ou davantage; on attendit que ces spermatozoïdes aient pénétré, à partir de l'éjaculat, dans du sérum sanguin (groupe AB Rh +) à une température de 37° C. L'examen prouva que, dans ces circonstances, la durée de la motilité des spermatozoïdes était supérieure à 24 heures, à une exception près. Dans 257 cas, la durée de la motilité des spermatozoïdes dans le sérum sanguin fut d'au moins 48 heures.

Dans la troisième partie du chapitre 3 (partie C), l'auteur décrit des recherches dont le but était d'avoir une impression du laps de temps après le coït durant lequel les spermatozoïdes sont encore à même de pénétrer dans la glaire cervicale à partir du sperme intravaginal (Tableau 6). Ces recherches ont démontré qu'après un séjour intravaginal de 20 minutes, les spermatozoïdes avaient d'une manière générale encore une vitalité suffisante pour que le résultat du test de M P S soit *assez bon* (fair) ou *bon* (good). Un séjour dans le vagin de 35 minutes ou davantage, réduisait la motilité des spermatozoïdes à tel point que le résultat de l'épreuve était dans la

plupart des cas *négatif*, *mauvais* (bad) ou *assez mauvais* (poor). La conclusion de ces recherches est qu'en empêchant le sperme de refluer hors du vagin pendant la demi-heure qui suit le coït, on peut favoriser la conception. Il semble cependant qu'empêcher ce reflux pendant plus d'une demi-heure, est dépourvu de sens.

Dans la quatrième partie du chapitre 3 (partie D) sont décrits les résultats de recherches faites au moyen du test de M P S dans le cadre d'un projet de recherche sur la contraception. On utilisa en l'occurrence 4 substances progestatives différentes, à savoir *l'acétate de noréthindrone*, *l'acétate de mégestrol*, *le lynestrénol* et *le Δ 5-10 lynestrénol*. 56 Femmes mariées, fécondes, qui ne désiraient provisoirement pas devenir enceintes à nouveau, utilisèrent, par groupe, un des progestatifs nommés ci-dessus, à raison de 0,5 mg par jour, en prise orale. Ce traitement visait à limiter la libération d'eau et de sel par les glandes cervicales dans une mesure telle que la viscosité de la glaire cervicale fût assez grande pour entraver la pénétration et la migration des spermatozoïdes dans la glaire cervicale au point d'empêcher le passage de spermatozoïdes à travers la colonne de glaire, dans le canal cervical. Il apparut qu'à quelques rares exceptions près, l'acétate de noréthindrone, l'acétate de mégestrol et le lynestrénol répondaient à cette exigence (Tableaux 7, 8 et 9); on fut cependant déçu par le Δ 5-10 lynestrénol (Tableau 10). Il apparut que cette substance exerçait une influence oestrogène et non une influence progestative sur les glandes cervicales; elle fut donc rapidement retirée du projet de recherches sur la contraception. Plus tard elle fut utilisée pour le traitement des femmes atteintes d'une stérilité involontaire, par suite de viscosité de la glaire. Un certain nombre de femmes ainsi traitées devinrent enceintes.

La cinquième partie du chapitre 3 (partie E) décrit des recherches dans lesquelles le M P S fut utilisé pour déceler la présence de *substances qui immobilisent les spermatozoïdes dans le sérum sanguin de femmes* ayant une stérilité non voulue. A cette fin, le réservoir de sperme était rempli d'éjaculat de l'époux, alors que le tube capillaire l'était de sérum sanguin frais de l'épouse.

Sur 278 couples ainsi examinés, il apparut qu'il n'y en avait que deux chez lesquels le test de l'immobilisation des spermatozoïdes, ainsi exécuté, était *positif*. Cinq fois le résultat fut *faiblement positif*. Chez ces sept femmes, il y avait une stérilité dont l'étiologie

n'était pas comprise. Chez l'une d'entre elles la présence d'agglutinines anti-spermatozoïdes fut démontrée dans le sérum sanguin (titre 1 : 512). Chez les six autres femmes, le test d'agglutination des spermatozoïdes donna un résultat négatif. Chez 41 autres couples atteints d'une stérilité dont on ne comprenait pas l'étiologie, la femme présenta 4 fois un test d'agglutination des spermatozoïdes positif, titrant respectivement 1 : 128, 1 : 32, 1 : 4 et 1 : 4. Le test d'immobilisation des spermatozoïdes fut négatif chez toutes ces 41 femmes. Ces recherches ne semblent pas indiquer que la présence d'immun-anticorps anti-spermatozoïdes dans le sérum sanguin de la femme soit une cause fréquente de stérilité involontaire, ainsi que le supposent certains chercheurs.

La sixième partie du chapitre 3 (partie F) donne les résultats de recherches faites au moyen du M P S et portant sur la présence de *substances immobilisant les spermatozoïdes dans le sérum sanguin de l'homme* (Tableaux 11, 12 et 13). Ces recherches prouvèrent que l'on pouvait trouver des agglutinines des spermatozoïdes dans le sang de la plupart des hommes, chez lesquels le test d'immobilisation des spermatozoïdes était positif. Il n'y eut que quelques cas dans lesquels le test d'immobilisation des spermatozoïdes était positif, tandis que le test d'agglutination des spermatozoïdes était négatif ou inversement.

La dernière partie du chapitre 3 (partie G) décrit 23 études comparatives de la forme des spermatozoïdes dans le sperme et de la forme des spermatozoïdes ayant pénétré, à partir de ce sperme, dans la glaire cervicale jusqu'à une profondeur supérieure à 3 cm, pendant le test de M P S (Tableau 14).

Il ressortit des résultats obtenus que, comparé au pourcentage initial dans le sperme, le pourcentage des spermatozoïdes à tête de forme anormale ayant pénétré, à partir du sperme, dans la glaire cervicale du tube capillaire jusqu'à une profondeur supérieure à 3 cm, avait diminué de 45 % (intervalle de variation de 12 à 88 %). Ceci indique que les spermatozoïdes qui atteignent les parties supérieures du tractus génital féminin ont au préalable été „triés” par la glaire cervicale („principe du filtre”).

Dans le chapitre 4 est décrit un examen comparatif, concernant les résultats de l'épreuve de pénétration des spermatozoïdes *in vitro*

selon la méthode classique de Miller et Kurzrok et selon la méthode du mètre de la pénétration des spermatozoïdes. Cet examen porta sur 52 couples différents. Les caractères physico-chimiques des échantillons de glaire cervicale utilisés étaient en partie favorables à la pénétration, à la migration et au maintien de la motilité des spermatozoïdes et en partie défavorables. Dans tous les éjaculats, la densité des spermatozoïdes fut d'au moins 20 millions par cm^3 , alors que la motilité fut du degré 3 pour au moins 40 % des spermatozoïdes. Au moins 50 % des spermatozoïdes avaient une tête de forme normale.

De ces recherches (Tableau 15), il ressortit qu'une disposition très nette en forme de „phalanges” dans le test de Miller et Kurzrok allait en général de pair avec une forte viscosité de la glaire cervicale. Aussi la pénétration des spermatozoïdes fut-elle faible ou nulle dans le test de Miller et Kurzrok; le test de M P S donna un mauvais résultat correspondant.

Dans 4 cas (8, 12, 26 et 41), le test de Miller et Kurzrok fut *fortement positif*, mais le résultat du test de M P S fut *négatif* ou *mauvais* (bad). Dans un de ces cas (12), il faut tenir compte de la possibilité d'une pseudo-pénétration dans le test de Miller et Kurzrok. Cette pseudo-pénétration n'est pas possible dans le test de M P S. Dans trois autres cas (8, 26 et 41), l'écart entre les résultats obtenus au moyen des deux épreuves était dû à la diminution rapide de la motilité qualitative des spermatozoïdes après leur pénétration dans la glaire cervicale. Ceci peut encore aller de pair avec un test de Miller et Kurzrok fortement positif, mais le résultat du test au moyen du M P S devient ainsi *mauvais* (bad).

Il y eut inversement 5 cas (17, 28, 38, 40 et 49) dans lesquels les résultats du test de pénétration selon la méthode de Miller et Kurzrok furent bien plus mauvais lorsqu'on utilisa le M P S. Il se peut que ceci doit être attribué au fait qu'on ne parvient pas toujours à délimiter nettement le sperme et la glaire cervicale dans le test de Miller et Kurzrok.

La conclusion que l'on peut tirer de ces recherches est que, d'une manière générale, les résultats du test de Miller et Kurzrok et ceux du test de M P S, correspondent assez bien entre eux. Dans le test de Miller et Kurzrok, les risques d'obtenir un résultat erroné sont cependant plus grands que dans le test de M P S. Cette épreuve pro-

cure en outre plus d'information que le test de Miller et Kurzrok, nommément en ce qui concerne la vitesse de migration et la durée de la motilité des spermatozoïdes dans la glaire cervicale.

Le chapitre 5 décrit un examen comparatif portant sur les résultats du test de Sims-Huhner et sur ceux de l'épreuve de pénétration des spermatozoïdes *in vitro*, exécutée au moyen du mètre de la pénétration des spermatozoïdes.

Dans la première partie du chapitre 5 sont discutées deux interprétations plus ou moins opposées des données que fournit le test de Sims-Huhner.

Selon l'une de ces interprétations, désignée sous le nom de „théorie du filtre”, des spermatozoïdes normaux franchiraient, pendant la phase ovulatoire, la colonne de glaire dans le canal cervical en peu de temps, cela à condition que les qualités physico-chimiques de la glaire cervicale permettent un passage aisé des spermatozoïdes. Les spermatozoïdes qui se trouvent encore dans la glaire cervicale quelques heures après le coït, doivent être considérés, d'après cette théorie, comme des spermatozoïdes de qualité inférieure qui ne sont pas à même de franchir la colonne de glaire cervicale assez rapidement. Si la technique du coït est bonne, si les appareils génitaux de l'homme et de la femme ont une anatomie normale, si le sperme est de bonne qualité et si la glaire cervicale est normale pour la période d'ovulation, un test de Sims-Huhner négatif ou mauvais s'inscrira, selon la „théorie du filtre”, en faveur d'une conception, un grand nombre de spermatozoïdes normaux ayant déjà migré vers les parties supérieures du tractus génital féminin. La présence de nombreux spermatozoïdes motiles dans la glaire cervicale, sera par contre défavorable à une conception, à moins que le test de Sims-Huhner n'ait été exécuté peu après le coït.

A l'encontre de la „théorie du filtre”, il y a la théorie de la „mise en dépôt”. Celle-ci part du point de vue que les spermatozoïdes ne peuvent passer de la glaire cervicale aux parties supérieures du tractus génital féminin qu'après l'ovulation. Elles utiliseraient le liquide folliculaire qui s'écoulerait après l'ovulation par les trompes homolatérales, du côté homolatéral de la cavité utérine en direction de la colonne de glaire cervicale. Ceci empêcherait les spermatozoïdes de „s'égarer” dans la cavité utérine. D'après „la

théorie de la mise en dépôt”, un test de Sims-Huhner qui permettrait de constater la présence pré-ovulatoire, dans la glaire cervicale, d’un grand nombre de spermatozoïdes d’une bonne motilité, serait favorable pour un pronostic de fertilité. Un test de Sims-Huhner négatif ou mauvais avant l’ovulation serait défavorable pour un pronostic de fertilité.

Un certain nombre d’autres arguments ont encore été évoqués pour ou contre les deux théories.

Dans la seconde partie du chapitre 5 sont décrits les résultats de 160 tests de Sims-Huhner, dont 160 couples différents furent l’objet. La glaire cervicale des femmes en question répondait dans tous les cas aux critères d’une glaire cervicale normale en phase ovulatoire. L’évaluation du pouvoir fécondant du sperme des hommes était: *stérile*, *mauvais* (bad), *assez mauvais* (poor), *passable* (passable) ou *bon* (good). Ces recherches (Tableau 16) démontrèrent qu’il y avait une corrélation positive entre l’évaluation du pouvoir fécondant du sperme et le résultat du test de Sims-Huhner, exécuté 2 à 8 heures après le coït dans tous les cas. Ce résultat semble indiquer que, pendant la phase ovulatoire, la glaire cervicale est également un *lieu de séjour temporaire pour les spermatozoïdes normaux* et qu’elle n’est pas seulement un „filtre” qui arrête les spermatozoïdes „inférieurs”, et laisse passer les spermatozoïdes normaux. Ceci ne veut pas dire que ce n’est qu’après l’ovulation que les spermatozoïdes remontent de leur lieu de séjour temporaire vers l’ampoule tubaire via le liquide folliculaire. Il est bien certain qu’avant l’ovulation aussi des spermatozoïdes peuvent atteindre le fond de l’utérus et les trompes, à partir de la glaire cervicale.

Chez 22 couples sur 57 chez lesquels le sperme du mari avait été qualifié de *bon* (good), le résultat du test de Sims-Huhner fut *néga-tif*, *très mauvais* (bad) ou *mauvais* (poor) (Tableau 16). Chez 16 couples sur 22, le résultat du test de M P S fut *assez bon* (fair), *bon* (good) ou *excellent* (excellent). Pour 12 couples sur 16, l’écart entre le résultat du test de Sims-Huhner et celui du test de M P S put être expliqué (dyspareunie, hypospadias du corps de la verge, troubles de l’émission du sperme, volume de l’éjaculat inférieur à 1 cm³, „facteur léta1” dans le vagin, persistance des mouvements du coït après l’émission du sperme, pénis anormalement court, attitude défavorable pendant le coït). En ce qui concerne les quatre autres

couples, il faut tenir compte de la possibilité d'un passage rapide des spermatozoïdes à travers la colonne de glaire cervicale dans le canal cervical.

Dans le cas des 6 couples (sur les 22 mentionnés ci-dessus), pour lesquels le résultat du test de Sims-Huhner fut bien inférieur à ce que l'analyse du sperme aurait permis d'espérer, le résultat du test de M P S fut conforme à celui du test de Sims-Huhner. Chez 3 de ces 6 couples, on obtint un résultat favorable en utilisant le test croisée de M P S pour laquelle la glaire cervicale provenait d'une femme probablement féconde et en phase ovulatoire. Pour les 3 autres couples, le résultat de ce test croisée correspondit à celui du test homologue de M P S, de sorte qu'il fallut chercher la cause du trouble de la pénétration dans le sperme.

Chez 15 couples sur 42, chez lesquels le sperme de l'homme avait été qualifié d'*assez mauvais* (poor), le résultat du test de Sims-Huhner fut cependant *assez bon* (fair), *bon* (good) ou *excellent* (excellent) (Tableau 16). Le test de M P S donna cependant un résultat *néglatif*, *très mauvais* (bad) ou *mauvais* (poor) dans ces 15 cas. Cet écart provenait probablement de la mauvaise influence que la collecte et le transport du sperme peuvent parfois avoir sur le pouvoir de pénétration des spermatozoïdes.

La conclusion finale du chapitre 5 est que, dans un certain nombre de cas, l'épreuve de pénétration des spermatozoïdes *in vitro*, exécutée à l'aide du mètre de la pénétration des spermatozoïdes (test de M P S), peut fournir des données qui apportent un complément important à l'information que procure l'épreuve de pénétration des spermatozoïdes *in vivo* (test de Sims-Huhner).

Zusammenfassung und Schlussfolgerungen

Das Ziel des Spermienpenetrationstests *in vitro* (hiernach *penetrationstest* genannt) ist es, festzustellen, ob und inwieweit die Spermien einer bestimmten Spermaprobe imstande sind, in Zervixschleim oder in eine andere Flüssigkeit einzudringen, wie und mit welcher Geschwindigkeit sie sich darin fortbewegen, und wie lange und in welchem Ausmass die eingedrungenen Spermien in dem betreffenden Medium beweglich bleiben.

Der Penetrationstest kann in verschiedener Weise und unter verschiedenen Bedingungen durchgeführt werden.

Ein derartiger Test muss, um als Routineteil der Fertilitätsuntersuchung beim Menschen eingesetzt werden zu können, folgenden Anforderungen entsprechen:

- a. Der Test muss mit einer einfachen Apparatur, die leicht zu bedienen ist, durchgeführt werden können.
- b. Der Test muss mit geringen Mengen des zu untersuchenden Materials ausgeführt werden können.
- c. Die Testergebnisse müssen reproduzierbar sein.
- d. Die Penetrationsdichte, die Penetrationstiefe, die Wanderungsgeschwindigkeit und die Beweglichkeitsdauer der Spermien in der betreffenden Flüssigkeit müssen mit ziemlicher Genauigkeit ermittelt werden können.

Im Kapitel 1 werden zwei Gruppen von Penetrationstesten besprochen, nämlich die *Deckglasmethoden* und die *Kapillarmethoden*. Die Deckglasmethoden haben den Nachteil, dass sich die Spermien hierbei nach der Penetration im Penetrationsmedium nach allen

Richtungen und nicht geradeaus fortbewegen. Dadurch besteht kein Zusammenhang zwischen der Penetrationstiefe und dem Abstand, den die Spermien im Penetrationsmedium zurückgelegt haben. Bei den Deckglasmethoden kann ausserdem die Wanderungsgeschwindigkeit nur schwer ermittelt werden, da die Spermien ihre Bewegungsrichtung stets wechseln. Schliesslich eignen sich die Deckglasmethoden im allgemeinen auch nicht für die Messung der Bewegungsdauer der Spermien im Penetrationsmedium bei einer Umgebungstemperatur von 37° C, da das Material eindrocknet. Mit Hilfe der Kapillarmethoden können die Penetrationsdichte, die Penetrationstiefe, die Wanderungsgeschwindigkeit und die Motilitätsdauer der Spermien im betreffenden Medium bestimmt werden. Die im Schrifttum beschriebenen Kapillarmethoden sind jedoch zu kompliziert oder liefern nicht ausreichend verlässliche Ergebnisse, um als Routineteil der Fruchtbarkeitsuntersuchung beim Menschen eingesetzt werden zu können.

Aus diesem Grunde wurde ein einfacher Apparat konstruiert, der den vorerwähnten Bedingungen auch wirklich entspricht. Dieser Apparat wurde *Spermienpenetrationsmesser* genannt (hiernach als S P M bezeichnet).

Im Kapitel 2 wird zuerst die *einfache* und *billige* Weise beschrieben, in der der S P M konstruiert wurde. In jeder Feinmechanikerwerkstätte, in der sich eine Glassäge befindet, kann der Apparat für wenig Geld innerhalb einer Stunde angefertigt werden. Danach wird beschrieben, auf welche Weise das für die Durchführung des Penetrationstests mit Hilfe des Spermienpenetrationsmessers im Rahmen der Fruchtbarkeitsuntersuchung beim Menschen benötigte Material gewonnen wurde, und wie der Transport, die Untersuchung und die Lagerung dieser Materialien vor dem Testbeginn erfolgte. Das Sperma beschafften wir uns, indem wir dem betreffenden Mann jeweils eine Anleitung und Transportmaterial übergaben. Wurde Zervixschleim als Penetrationsmedium verwendet, dann wurde dieser mit einer speziell für diesen Zweck entworfenen Zange dem Zervixkanal entnommen, auf einen Objektträger gebracht, und danach bis Testbeginn in einer feuchten Petrischale gelagert. Wurde der Zervixschleim über längere Zeit gelagert, dann wurde er in Glaskapillaren aufgezogen, die an den beiden Enden mit Knetwachs ab-

geschlossen und in einen für diesen Zweck speziell konstruierten Halter in den Kühlschrank gesetzt wurden. Wurde Blutserum als Penetrationsmedium verwendet, dann wurde dieses durch Venenpunktion und Zentrifugieren des Blutes gewonnen. Nötigenfalls wurde das Serum in tiefgefrorenem Zustand gelagert.

Aufgrund der Dichte, der quantitativen Beweglichkeit, der qualitativen Beweglichkeit und der Morphologie der Spermien im Ejakulat wurde von jedem Ejakulat ein „Fertilitätsgrad“ errechnet, und zwar auf der Grundlage einer Punktwertung.

Vom Zervixschleim wurden die *Helligkeit*, die *Viskosität*, die *Spinnbarkeit*, der *Säuregrad*, der *Glukosegehalt* und die Fähigkeit zur Auskristallisierung in Form einer *Farnstruktur* bestimmt. Die Helligkeit wurde in Graden ausgedrückt. Für die Bestimmung der Viskosität wurde der Viskositätsmesser nach Scott Blair verwendet. Die Spinnbarkeit wurde mit Hilfe einer selbst entworfenen Methode bestimmt. Die Bestimmung des Säuregrades und des Glukosegehalts erfolgte mit Reagenzpapier. Für die Ausführung des Farntests wurde der Zervixschleim auf einem Objektträger getrocknet.

Im letzten Teil des Kapitels 2 wird die Durchführung des Penetrationstests mit Hilfe des Spermienpenetrationsmessers (hiernach S P M-Test genannt) ausführlich dargelegt. Vor Testbeginn wurden dem Ejakulat pro cm^3 500 E. Penicillin und 0,5 mg Neomycin zugefügt, um Bakterienwachstum zu verhindern.

Kapitel 3 nennt die Ergebnisse des S P M-Tests.

Im ersten Teil dieses Kapitels (Teil A) werden die Ergebnisse einiger Untersuchungen hinsichtlich der Brauchbarkeit des Tests als Teil der Fruchtbarkeitsuntersuchung beim Menschen angeführt.

Aus den Ergebnissen dieser Untersuchungen konnten folgende Schlussfolgerungen gezogen werden:

- a. Ein passives Übertreten von Spermien aus dem mit Sperma gefüllten Samenreservoir in die mit Zervixschleim gefüllte Glaskapillare findet nicht statt.
- b. Ein passives Übertreten von Spermien aus dem mit Sperma gefüllten Samenreservoir in die mit Blutserum gefüllte Glaskapillare kann verhindert werden, indem man den S P M stets horizontal hält und nur vorsichtig von der Stelle bewegt.
- c. Die Temperatur der Umgebung beeinflusst das Ergebnis des

S P M-Tests. Die Penetrationsdichte und die Wanderungsgeschwindigkeit von Spermien im Blutserum liegen bei 40° C und bei 37° C höher als bei Zimmertemperatur, während die Beweglichkeitsdauer bei 40° C kürzer ist als bei 37° C und bei 37° C kürzer als bei Zimmertemperatur (Tabelle 1).

- d. Wird im S P M menschliches Blutserum als Penetrationsmedium verwendet, dann sind die Ergebnisse des S P M-Tests besser als wenn eine isotonische Glukose-Salzlösung, ein kolloidales Plasmasubstitut oder eine pasteurisierte Lösung von menschlichem Plasmaeiweiß verwendet wird (Tabelle 2).
- e. Die Lagerung von Blutserum in tiefgefrorenem Zustand beeinflusst das Ergebnis des S P M-Tests nicht, wenn dieses tiefgefrorene Blutserum nach dem Auftauen als Penetrationsmedium verwendet wird.
- f. Die Ergebnisse des S P M-Tests sind ausreichend reproduzierbar, um diesen Test als Teil der Fruchtbarkeitsuntersuchung beim Menschen zu verwenden.

Im zweiten Teil des Kapitels 3 (Teil B) werden die Ergebnisse der Untersuchung mit dem S P M als Routineteil der Suche nach den Ursachen der ungewollten Sterilität beim Menschen angeführt.

Bei der Verwendung normalen Zervixschleims aus der Ovulationsperiode als Penetrationsmedium zeigte sich, dass die *Dichte* und die *Motilität* der Spermien im Ejakulat das Testergebnis deutlich beeinflussten. Der Einfluss der *Morphologie* der Spermien war weniger deutlich.

Die Untersuchung umfasste 135 verschiedene Ehepaare. Bei allen diesen Frauen war der Zervixschleim während der Ovulationsphase normal; der „Fertilitätsgrad“ der 135 Ejakulate war sehr unterschiedlich (Tabellen 3, 3a, 3b, 3c, 3d und 3e).

Bei der Gruppe von Ejakulaten mit einer *Spermiendichte* von weniger als 20 Millionen pro cm³ Ejakulat war das Ergebnis signifikant schlechter als bei der Gruppe von Ejakulaten mit einer Spermiendichte von 20 Millionen oder mehr pro cm³ Ejakulat. Bei der Ejakulat-Gruppe mit einer Spermiendichte von 60 Millionen oder mehr pro cm³ Ejakulat war das Ergebnis signifikant besser als bei einer Spermiendichte von 20-60 Millionen pro cm³ (Tabelle 3a).

Bei der Gruppe von Ejakulaten, bei der die *quantitative Spermienmotilität* im Ejakulat weniger als 40 % betrug, war das Ergebnis

signifikant schlechter als bei der Gruppe von Ejakulaten mit einer quantitativen Spermienmotilität von 40-60 %. Die Ejakulat-Gruppe mit einer quantitativen Spermienmotilität von 60 % oder mehr zeigte kein besseres Ergebnis als die Gruppe mit einer quantitativen Motilität von 40-60 % (Tabelle 3b). Es zeigte sich, dass auch die *qualitative Spermienbeweglichkeit* das Ergebnis des S P M-Tests beeinflusste. Vor allem wenn der Motilitätsgrad 3 erreicht wurde, konnte ein auffällig besseres Ergebnis beobachtet werden (Tabelle 3c).

Der Einfluss der *Morphologie* der Spermien auf das Ergebnis des S P M-Tests in vitro war weniger deutlich als der Einfluss der Dichte und Motilität. Das ist wahrscheinlich auf den Umstand zurückzuführen, dass man einen hohen Prozentsatz abnormaler Kopfformen in einer Spermienpopulation mit guter Dichte und guter Beweglichkeit antreffen kann. Auch exogene Faktoren können die Motilität der Spermien im Ejakulat ungünstig beeinflussen, während die Morphologie dabei immer unverändert bleibt (Tabelle 3d.).

Erfolgte aufgrund der Dichte, der Motilität und der Morphologie der Spermien im Ejakulat eine Beurteilung der Fertilität des Spermas, dann zeigte sich, dass eine starke Beziehung zwischen dem Ergebnis dieser Fertilitätsbeurteilung und dem Ergebnis des S P M-Tests vorlag (Tabelle 3e).

Bei 25 der vorerwähnten 135 Ehepaare zeigte sich, dass im S P M die qualitative Beweglichkeit der Spermien am Ende der Glaskapillare 2 Stunden nach Testbeginn schlechter war als am Anfang der Glaskapillare (Tabelle 3). Das wurde im Hinblick auf die Konzeptionsmöglichkeit als ungünstig gewertet.

In Tabelle 4 werden die Ergebnisse des S P M-Tests bei 50 verschiedenen Ehepaaren angeführt, bei denen der Fertilitätsgrad des Spermas als *gut* (good) beurteilt wurde, bei denen jedoch eine oder mehrere physiko-chemische Eigenschaften des Zervixschleimes den Kriterien für normalen Zervixschleim aus der Ovulationsphase nicht gerecht wurden. Aus dieser Untersuchung ging hervor, dass, wenn die Viskosität des Zervixschleimes 5,5 oder mehr betrug, der Endpunkt der Glaskapillare von den Spermien nicht erreicht wurde. Das Ergebnis des Tests war dann immer *negativ*, *schlecht* (bad) oder *ziemlich schlecht* (poor). War die Spinnbarkeit des Zervixschleimes 30 mm oder weniger, oder war der Farntest negativ, dann war das Ergebnis ebenfalls in allen Fällen *negativ*, *schlecht* (bad) oder *ziem-*

lich schlecht (poor). Eine saure Reaktion des Zervixschleimes, wobei der pH von 6,3 bis 7 variierte, beeinflusste das Ergebnis des S P M-Tests nicht ungünstig. Der Glukosegehalt des Zervixschleimes hatte keinen Einfluss.

Bei 54 verschiedenen Ehepaaren, bei denen der Samen als normal fertil zu bezeichnen war, und bei denen der Zervixschleim den Kriterien eines normalen Zervixschleimes aus der Ovulationsperiode entsprach, wurde mit dem S P M bei Zimmertemperatur die Fortbewegungsgeschwindigkeit von Spermien im Zervixschleim untersucht. Die durchschnittliche Geschwindigkeit betrug 1,8 mm pro Minute, mit einer Streubreite von 1-2,8 mm. (Tabelle 5).

Bei 310 Männern mit einem oder mehreren Kindern wurde mit dem S P M die Motilitätsdauer ihrer Spermien untersucht, nachdem diese bei einer Temperatur von 37° C aus dem Ejakulat in Blutserum (Blutgruppe AB Rh+) penetriert waren. Aus dieser Untersuchung ging hervor, dass die Motilitätsdauer der Spermien unter den angeführten Umständen mit einer einzigen Ausnahme mehr als 24 Stunden betrug. In 257 Fällen betrug die Motilitätsdauer der Spermien im Blutserum mindestens 48 Stunden.

Im dritten Teil des Kapitels 3 (Teil C) wird eine Untersuchung beschrieben, deren Ziel es war, eine Information über die Zeitdauer, während der Spermien nach dem Koitus noch imstande sind, aus dem intravaginalen Sperma in den Zervixschleim einzudringen, zu erhalten (Tabelle 6). Aus dieser Untersuchung ging hervor, dass die Spermien nach 20 minutigem Verweilen in der Vagina im allgemeinen noch so vital waren, dass das Ergebnis des S P M-Tests als *günstig* (fair) oder *gut* (good) zu bezeichnen war. Verweilten die Spermien jedoch 35 Minuten oder länger in der Vagina, dann nahm die Motilität der Spermien so sehr ab, dass das Testergebnis in der Mehrzahl der Fälle *negativ*, *schlecht* (bad) oder *ziemlich schlecht* (poor) war. Aus dieser Untersuchung ist zu folgern, dass die Konzeptionsmöglichkeit angehoben werden kann, wenn der Samenrückfluss aus der Vagina nach dem Koitus eine halbe Stunde lang verhindert wird. Es dürfte jedoch wenig Sinn haben, den Samenrückfluss aus der Vagina länger als eine halbe Stunde hindurch zu verhindern.

Im vierten Teil des Kapitels 3 (Teil D) werden die Ergebnisse einer Untersuchung mit dem S P M-test als Teil eines Antikonzeptions-Forschungsprojektes beschrieben. Dabei wurden vier verschie-

dene progestative Stoffe verwendet, und zwar Norethindronacetat, Megestrolacetat, Lynestrenol und $\Delta 5$ -10Lynestrenol. 56 Fertile, verheiratete Frauen, die vorläufig nicht wieder schwanger werden wollten, nahmen gruppenweise eines der genannten Progestativa in einer Dosierung von 0,5 mg täglich, in der Form einer oral einzunehmenden Tablette ein. Auf diese Weise sollte die Wasser- und Salzabgabe der Zervixdrüsen soweit eingeschränkt werden, dass die Viskosität des Zervixschleimes hoch genug würde, um die Penetration und die Migration von Spermien in und durch denselben so sehr zu erschweren, dass die Spermien den Schleimpropfen im Zervixkanal nicht passieren können. Norethindronacetat, Megestrolacetat und Lynestrenol entsprachen mit ganz wenigen Ausnahmen dieser Forderung (Tabelle 7, 8 und 9); $\Delta 5$ -10Lynestrenol jedoch enttäuschte (Tabelle 10). Es zeigte sich, dass der letztgenannte Stoff die Zervixdrüsen nicht progestativ sondern östrogen beeinflusste, weswegen er rasch aus dem Antikonzeptions-Forschungsprojekt ausgeschieden wurde. Später wurde er für die Behandlung von Frauen, die infolge zähen Zervixschleimes ungewollt steril waren, eingesetzt. Bei einer Reihe solcherart behandelter Frauen trat Schwangerschaft ein.

Im fünften Teil des Kapitels 3 (Teil E) wird eine Untersuchung beschrieben, bei der der SPM für das Aufspüren spermienimmobilisierender Stoffe im Blutserum von ungewollt sterilen Frauen herangezogen wird. Zu diesem Zweck wurde das Samenreservoir mit dem Ejakulat des Ehemannes gefüllt, die Glaskapillare mit frischem Blutserum der Ehefrau. Von 278 untersuchten Ehepaaren war der auf diese Weise durchgeführte Spermienimmobilisationstest nur bei 2 Paaren positiv, während das Ergebnis fünfmal schwach positiv ausfiel. Bei diesen 7 Frauen lag eine unerklärliche Sterilität vor. Bei einer von ihnen wurden spermienfeindliche Agglutinine im Blutserum nachgewiesen (Titer 1 : 512). Bei den sechs anderen Frauen war der Spermienagglutinationstest negativ. Bei 41 anderen Ehepaaren mit unerklärlicher Sterilität wurde bei der Frau 4 mal ein positiver Spermienagglutinationstest angetroffen, wobei die Titer 1 : 128, 1 : 32, 1 : 4 und 1 : 4 betragen. Der Spermienimmobilisationstest war bei diesen 41 Frauen negativ. Die beschriebene Untersuchung spricht nicht dafür, dass die Anwesenheit spermienfeindlicher Immunantikörper im Blutserum der Frau eine häufige Ursache ungewollter Sterilität ist, wie dies verschiedene Untersucher angenommen haben.

Der sechste Teil des Kapitels 3 (Teil F) führt die Ergebnisse einer Untersuchung nach dem Vorliegen spermienimmobilisierender Stoffe im Blutserum des Mannes mit Hilfe des Spermienpenetrationsmessers an (Tabellen 11, 12 und 13). Diese Untersuchung ergab, dass bei den meisten Männern, bei denen der Spermienimmobilisationstest positiv war, Spermienagglutinine im Blut nachgewiesen werden konnten. Nur in einigen Fällen war der Spermienimmobilisationstest positiv und der Spermienagglutinationstest negativ oder umgekehrt.

Im letzten Teil des Kapitels 3 (Teil G) wird eine vergleichende Untersuchung von 23 Fällen beschrieben, und zwar hinsichtlich der Morphologie der Spermien im Sperma und der Morphologie der Spermien, die während des SPM-Tests aus diesem Sperma mehr als 3 cm tief in Zervixschleim penetriert waren (Tabelle 14).

Aus den Ergebnissen dieser Untersuchung ging hervor, dass von den Spermien, die aus dem Sperma tiefer als 3 cm in den Zervixschleim in der Glaskapillare eingewandert waren, der Prozentsatz abnormaler Kopfformen um durchschnittlich 45 % abgenommen hatte (Streuungsbreite 12-88 %). Das weist darauf hin, dass Spermien, die die höher gelegenen Teile des weiblichen Genitaltrakts erreichen, schon vorher durch den Zervixschleim „selektiert“ wurden („Filterprinzip“).

Im Kapitel 4 wird eine vergleichende Untersuchung hinsichtlich der Ergebnisse des Penetrationstests nach der klassischen Methode von Miller und Kurzrok, und nach der Methode mit dem SPM beschrieben. Diese Untersuchung wurde bei 52 verschiedenen Ehepaaren durchgeführt. Die physiko-chemischen Eigenschaften der verwendeten Zervixschleimproben waren für die Penetration, die Migration und die Aufrechterhaltung der Beweglichkeit der Spermien zum Teil günstig und zum Teil ungünstig. Alle Ejakulate hatten eine Spermiedichte von mindestens 20 Millionen pro cm^3 . Die Motilität der Spermien betrug mindestens 40 % - Grad 3. Mindestens 50 % der Spermien hatten normale Kopfform.

Diese Untersuchung (Tabelle 15) zeigte, dass eine starke Phalanxbildung im Miller-Kurzrok-Test in der Regel mit einer hohen Viskosität des Zervixschleimes Hand in Hand ging. Es gab dann keine oder nur geringe Spermienpenetration im Miller-Kurzrok-Test selbst;

der Test mit dem S P M ergab damit übereinstimmende schlechte Resultate.

In 4 Fällen (8, 12, 26 und 41) war der Miller-Kurzrok-Test *stark positiv*, das Testergebnis mit dem S P M jedoch *negativ* oder *schlecht* (bad). In einem dieser Fälle (12) muss man mit der Möglichkeit einer Pseudopenetration im Miller-Kurzrok-Test rechnen. Diese Pseudopenetration ist im S P M nicht möglich. In den drei anderen Fällen (8, 26 und 41) ist die Diskrepanz zwischen den Ergebnissen der beiden Teste durch die rasche Abnahme der qualitativen Motilität der Spermien nach der Penetration in den Zervixschleim verursacht. Dabei kann der Miller-Kurzrok-Test noch *stark positiv* ausfallen, das Ergebnis des Tests mit dem S P M wird aber dadurch *schlecht* (bad).

Andererseits gab es fünf Fälle (17, 28, 38, 40 und 49), bei denen das Ergebnis des Penetrationstests nach der Methode von Miller und Kurzrok weit schlechter war als dasjenige mit dem S P M. Möglicherweise ist das dem Umstand zuzuschreiben, dass es nicht immer gelingt, beim Miller-Kurzrok-Test eine gute Grenzfläche zwischen Sperma und Zervixschleim zu erhalten.

Die Schlussfolgerung des Kapitels 4 lautet, dass die Ergebnisse des Miller-Kurzrok-Tests und diejenigen des S P M-Tests im allgemeinen ziemlich gut übereinstimmen. Beim Miller-Kurzrok-Test ist jedoch die Möglichkeit eines falschen Ergebnisses grösser als beim S P M-Test. Überdies liefert der S P M-Test mehr Informationen als der Miller-Kurzrok-Test, insbesondere im Hinblick auf die Wandergeschwindigkeit und die Beweglichkeitsdauer der Spermien im Zervixschleim.

Kapitel 5 beschäftigt sich mit einer vergleichenden Untersuchung der Ergebnisse des Sims-Huhner-Tests und des S P M-Tests.

Im ersten Teil des Kapitels 5 werden zwei mehr oder weniger gegensätzliche Auffassungen über die Beurteilung des Sims-Huhner-Tests besprochen.

Der einen Auffassung nach, die als „Filtertheorie“ bezeichnet wird, sollen normale Spermien nach dem Koitus während der Ovulationsphase den Schleimpropfen im Zervixkanal innerhalb kurzer Zeit durchwandern, wenn die physiko-chemischen Qualitäten des Zervixschleimes einen raschen Spermiedurchgang erlauben. Die

Spermien, die sich einige Stunden nach dem Koitus noch im Zervixschleim befinden, sind dieser Theorie zufolge als minderwertig zu betrachten, weil sie nicht imstande sind, den Schleimpropfen entsprechend rasch zu durchqueren. Bei guter Koitustechnik, normaler Anatomie des männlichen und weiblichen Genitalapparates, gutem Sperma und normalem Ovulationszervixschleim gilt nach der „Filtertheorie“ ein negativer oder schlechter Sims-Huhner-Test im Hinblick auf die Konzeptionsmöglichkeit als günstig. Es sind dann viele normale Spermien in die höher gelegenen Teile des weiblichen Genitaltraktes gelangt. Das Vorhandensein vieler gut beweglicher Spermien im Zervixschleim ist dagegen für die Konzeptionsmöglichkeit ungünstig, es sei denn, dass der Sims-Huhner-Test kurz nach dem Koitus durchgeführt wurde.

Das Gegenstück der „Filtertheorie“ ist die „Depottheorie“. Sie geht davon aus, dass Spermien erst nach der Ovulation aus dem Zervixschleim in die höheren Teile des weiblichen Genitaltraktes aufsteigen können. Dabei sollen sie sich die Follikelflüssigkeit zunutze machen, die nach der Ovulation durch die homolaterale Tube entlang der homolateralen Seitenwand des Cavum uteri zum Schleimpropfen im Zervixkanal fließen soll. Dadurch soll das „Verirren“ der Spermien im Cavum uteri verhindert werden. Dieser „Depottheorie“ zufolge soll ein Sims-Huhner-Test, bei dem vor der Ovulation viele gut bewegliche Spermien im Zervixschleim angetroffen werden, für die Fruchtbarkeitsprognose als günstig zu werten sein. Ist jedoch das Ergebnis des Sims-Huhner-Tests vor der Ovulation negativ oder schlecht, dann habe dies für die Fertilitätsprognose als ungünstig zu gelten.

Es wird eine Reihe von Argumenten für und gegen die beiden Theorien angeführt.

Im zweiten Teil des Kapitels 5 werden die Ergebnisse von 160 Sims-Huhner-Testen besprochen, die bei 160 verschiedenen Ehepaaren ausgeführt wurden. Der Zervixschleim der betreffenden Frauen entsprach in allen Fällen den Kriterien für normalen Zervixschleim aus der Ovulationsphase.

Die Fertilitätsbeurteilung des Spermas der Männer war *steril*, *schlecht* (bad), *ziemlich schlecht* (poor), *ausreichend* (passable) oder *gut* (good).

Aus dieser Untersuchung (Tabelle 16) ging hervor, dass eine po-

sitive Beziehung zwischen der Fertilitätsbeurteilung des Spermas und dem Ergebnis des Sims-Huhner-Tests, der bei allen Ehepaaren 2-8 Stunden nach dem Koitus durchgeführt worden war, bestand. Dieses Ergebnis spricht dafür, dass während der Ovulationsperiode der Zervixschleim auch ein vorübergehender *Aufenthaltort für normale Spermien* ist und nicht ausschliesslich ein „Filter“, der „minderwertige“ Spermien aufhält und normale Spermien passieren lässt. Das bedeutet nicht, dass die normalen Spermien erst nach der Ovulation von diesem vorübergehenden Aufenthaltsort via die Follikelflüssigkeit zur Pars ampullaris tubae aufsteigen. Es steht wohl fest, dass Spermien auch vor der Ovulation vom Zervixschleim aus den Fundus uteri und die Tuben erreichen können.

Bei 22 von 57 Ehepaaren, bei denen das Sperma des Mannes als *gut* (good) klassifiziert worden war, war das Ergebnis des Sims-Huhner-Tests *negativ, sehr schlecht* (bad), oder *schlecht* (poor) (Tabelle 16). Bei 16 dieser 22 Ehepaare war jedoch das Ergebnis des S P M-Tests *ziemlich gut* (fair), *gut* (good) oder *sehr gut* (excellent). Bei 12 dieser 16 Ehepaare konnte eine Erklärung für die Diskrepanz zwischen dem Ergebnis des Sims-Huhner-Tests und demjenigen des S P M-Tests gefunden werden (Dyspareunie, Hypospadie des Penis, gestörte Ejakulation, Ejakulatvolumen geringer als 1 cm³, „Letalfaktor“ in der Vagina, Fortsetzung der Kohabitationsbewegungen nach der Ejakulation, abnormal kurzer Penis, ungünstige Kohabitationsstellungen). Bei den vier restlichen Ehepaaren muss mit der Möglichkeit einer raschen Spermienpassage durch den Schleimpropfen im Zervixkanal gerechnet werden.

Bei 6 der 22 vorerwähnten Ehepaare, bei denen das Ergebnis des Sims-Huhner-Tests viel schlechter war als man aufgrund der Spermaanlyse hätte erwarten dürfen, entsprach das Ergebnis des S P M-Tests demjenigen des Sims-Huhner-Tests. Bei 3 dieser 6 Ehepaare war das Ergebnis eines gekreuzten S P M-Tests, bei dem Zervixschleim aus der Ovulationsperiode einer vermutlich fertilen Frau verwendet wurde, *gut*. Bei den 3 restlichen Ehepaaren stimmte das Ergebnis dieses gekreuzten S P M-Tests mit demjenigen des homologen S P M-Tests überein, so dass die Ursache der Penetrationsstörung im Sperma zu suchen war.

Bei 15 von 42 Ehepaaren, bei denen das Sperma des Mannes als *ziemlich schlecht* (poor) klassifiziert worden war, lautete das Ergebnis

des Sims-Huhner-Tests trotzdem *ziemlich* gut (*fair*), *gut* (good) oder *sehr gut* (excellent) (Tabelle 16). Der SPM-Test war jedoch bei diesen 15 Ehepaaren *negativ*, *sehr schlecht* (bad) oder *schlecht* (poor). Diese Diskrepanz war wahrscheinlich auf den ungünstigen Einfluss, den das Auffangen und der Transport des Spermas mitunter auf die Penetrationsfähigkeit der Spermien ausüben kann, zurückzuführen.

Die Schlussfolgerung des Kapitels 5 lautet, dass der Spermienpenetrationstest *in vitro*, mit dem Spermienpenetrationsmesser durchgeführt (SPM-Test), in einer Reihe von Fällen Aufschlüsse zu verschaffen vermag, die als wichtige Ergänzung der mit Hilfe des Spermienpenetrationstests *in vivo* (Sims-Huhner-Test) gewonnenen Information gewertet werden können.

references

- AMELAR, R. D. and HOTCHKISS, R. S.
Congenital aplasia of the epididymides and vasa deferentia: Effects on semen.
Fertil. and Steril. 14 : 44, 1963.
- AMELAR, R. D. and HOTCHKISS, R. S.
The split ejaculate. Its use in the management of male infertility.
Fertil. and Steril. 16 : 46, 1965.
- BANDHAUER, K.
Untersuchungen über immunbiologische Ursachen der männlichen Sterilität.
Klin. Med., 18, 204, 1963.
- BARTON, M. and WIESNER, B. P.
The receptivity of cervical mucus to spermatozoa.
Brit. med. J. II, 606, 1946.
- BASKEN, M. J.
Temporary sterilization by the injection of human spermatozoa. (A preliminary report.)
Am. J. Obst. Gynec. 24 : 892, 1932.
- BERHMAN, S. J.
Immunologic aspects of infertility.
Intern. J. Fertil. 6 : 349, 1961.
- BERGMAN, P.
Sperm migration and its relation to the morphology and motility of spermatozoa.
Intern. J. Fertil. 1 : 45, 1955.
- BERGMAN, P. and FERBAS, E.
A test for sperm migration analysis in artificial medium.
Int. Journ. Fertil. 6 : 279, 1961.
- BERGMAN, P. and GENNSER, G.
Investigation of sperm migration in artificial medium.
Acta Obst. et Gynaec. scandinav. I, P. suppl. 1 : 98, 1959.
- BOTELLA-LLUSIA, J.
Measurement of linear progression of the human spermatozoon as an index of male fertility.
Int. J. Fertil. 1 : 113, 1956.
- BOTELLA-LLUSIA, J.
La vitesse de progression spermatique comme index de fertilité du male. Colloque sur la fonction spermatogénétique du testicule 10-12 Juillet 1958, Paris.

- BOTELLA-LLUSIA, J.**
Methods for determining the type and the degree of spermatic motility.
Proceedings of the fifth world congress of Fertility and Sterility, Stockholm,
June 16-22, 1966.
- BROWN, R. L.**
Sperm fluctuations in health and disease.
South. Med. J. 36 : 619-624, 1943.
- BROWN, R. L.**
Rate of transport of sperma in human uterus and tubes.
Am. J. Obst. and Gynec. 47 : 407, 1944.
- CARY, W. H.**
Duration of sperm cell migration in uterine secretions.
J.A.M.A. 106 : 2221-2223, 1936.
- CHARNY, C. W.**
Effect of varicocele on fertility.
Fertil. and Steril. 13 : 47, 1962.
- CLIFT, A. F.**
Observations on certain rheological properties of human cervical secretion.
Proc. Roy. Soc. Med. London, 39 : 1, 1945.
- COHEN, M. R. and STEIN, I. F.**
Sperm survival at estimated ovulation time.
Fertil. and Steril. 2 : 20, 1951.
- COHEN, M. R., STEIN, I. F. and KAYE, B. M.**
Spinnbarkeit: A characteristic of cervical mucus.
Fertil. and Steril. 3 : 201, 1952.
- COHEN, M. R., STEIN, I. F. and KAYE, B. M.**
Optimal time for therapeutic insemination: Spinnbarkeit as the preferred
criterion.
Fertil. and Steril. 7 : 141, 1956.
- CRUICKSHANK, B. and STUART-SMITH, D. A.**
Orchitis associated with sperm-agglutinating anti-bodies.
Lancet I, 708, 1959.
- DANEZIS, J., SABITA SUJAN and SOBRERO, A. J.**
Bacteriology of the cervix and postcoital tests.
Int. J. of Fertil. 7 : 215, 1962.
- DANEZIS, J., SABITA SUJAN and SOBRERO, A. J.**
Evaluation of the postcoital test.
Fertil. and Steril. 13 : 559, 1962.
- DOYLE, J. B.**
The cervical spoon: a new method of semen sampling and assaying sperm
migration; a preliminary report.
J. Urol. 60 : 986, 1948.
- DOYLE, J. B.**
Cervical Tampon and Spoon.
J. Obst. and Gynec. 12 : 433, 1958.
- FARRIS, E. J. and MURPHY, D. P.**
The characteristics of the two parts of the partitioned ejaculate and the
advantages for intra-uterine insemination.
Fertil. and Steril. 11 : 465, 1960.
- FJÄLLBRANT, Bo.**
Immuno-agglutination of sperm in cases of sterility.
Acta Obst. et Gynec. Scandinav. 44, 474, 1965.
- FLUHMANN, C. F.**
Irregularity of the stages of the menstrual cycle.
Western J. Surg. 65 : 265-277, 1957.

- FRAENKEL, L.
Sterilisierung und Konzeptionsverhütung.
Arch. Gynäk. 144 : 86, 1930.
- FRANKLIN, R. R. and DEAN DUKES, C.
Antispermatozoal antibody and unexplained infertility.
Am. J. Obst. and Gynec. 89 : 6, 1964.
- FRENKEL, D. A.
Sperm migration and survival in the endometrial cavity.
Intern. J. Fertil. 6 : 285, 1961.
- GIBBONS, R. A.
Chemical properties of two mucoids from bovine cervical mucus.
Biochem. J. 73 : 209, 1959.
- GIBBONS, R. A. and GLOVER, F. A.
Physico-chemical properties of two mucoids from bovine cervical mucin.
Biochem. J. 73, 217, 1959.
- GIBBONS, R. A. and GLOVER, F. A.
The flow birefringence of purified bovine cervical mucoid.
In Copley, A. L. and Stainsby, G.
Flow properties of blood and other biological systems.
Pergamon Press, New York and London, 1960, pp. 234-247.
- GLOVER, T. D. and YOUNG, D. H.
Temperature and the production of spermatozoa.
Fertil. and Steril. 14 : 441, 1963.
- GRANT, A.
Cervical Hostility.
Fertil. and Steril. 9 : 321, 1958.
- GUARD, H. R.
New Technic for sperm-mucus penetration tests, using a hemocytometer.
Fertil. and Steril. 11 : 392, 1960.
- HARVEY, C. and JACKSON, M. H.
Penetration of cervical mucus by spermatozoa.
Lancet, 723, 1948.
- HELLINGA, G.
Het onderzoek bij stoornissen in de mannelijke vruchtbaarheid.
Acad. Proefschrift 1949.
- HOLT, J. G. H.
Coital or masturbational sperm sample?
Proceedings of the Second World Congress on Fertility and Sterility,
Naples 1956.
- HUGGINS, C. B. and NEAL, W.
Coagulation and liquefaction of semen.
J. Exp. Med. 76 : 527, 1942.
- HUHNER, MAX.
Sterility in the male and female and its treatment.
Rebman Co., New York 1913.
- HUHNER, M.
Necrostermia and viability of spermatozoa in the cervical canal.
J.A.M.A. 107 : 1581, 1936.
- JOËL, C. A.
Spermienbeweglichkeit und Antibiotica.
Gynaecologia 146 : 53, 1958.
- KERNER, J. A.
An instrument for the Sims-Huhner test.
Am. J. Obst. and Gynec. 66 : 909, 1953.
- KLEEGMAN, S. J.
Sterility.
Am. J. Surg. 33 : 392, 1936.

- KLEEGMAN, S. J. and KAUFMAN, S. A.
Infertility in women.
F. A. Davis Company, Philadelphia 1966.
- KREMER, J.
A simple sperm penetration test.
Int. J. of Fert. 10 : 209, 1965.
- KREMER, J.
A new method of sperm utilization. Excerpta Medica International Congress Series no. 133.
Proceedings of the fifth World Congress of fertility and sterility, Stockholm, June 16-22, 1966.
- KREMER, J.
Bilaterale regressie van de gang van Wolff, een weinig bekende, doch relatief vaak voorkomende oorzaak van obstructieve azoöspermie.
N.T.v.G. 111, 2120, 1967.
- KURZROK, R. and BIRNBERG, C.
A study of semen mucus penetration and its relation to a test for ovulation.
Intern. J. Fertil. 3 : 134, 1958.
- LAMAR, J. K., SHETTLES, L. B. and DELFS, E.
Cyclic penetrability of human cervical mucus to spermatozoa in vitro.
Am. J. Physiol. 129 : 234, 1940.
- LANE ROBERTS, C., CHARMAN, A., WALKER, K. and WIESNER, B. P.
Sterility and impaired fertility.
Hamish Hamilton, London 1948.
- LEVIE, L. H.
Seksuologie; handleiding voor artsen.
Uitg. L. Stafleu & Zoon, Leiden, 1961.
- LÜBKE, F. H.
Ueber die Bedeutung der Spermaqualität für die Penetrationsteste in vivo.
Geburtsh. u. Frauenheilk. 27 : 283, 1967.
- LUNDQUIST, F., THORSTEINSSON, T. and BUUS, O.
Purification and properties of some enzymes in human seminal plasma.
Biochem. J. 59 : 69, 1955.
- MC.LANE, C. M.
Symposium on Infertility.
Foreword Clin. Obs. & Gyn. 8 : 11, 1965.
Quarterly. Hoeber Med. Div., Harper & Row, New York.
- MACLEOD, J.
Effect of chickenpox and of pneumonia on semen quality.
Fertil. and Steril. 2 : 523-533, 1951.
- MACLEOD, J.
A testicular response during and following a severe allergic reaction.
Fertil. and Steril. 13 : 531, 1962.
- MACLEOD, J. and GOLD, R. Z.
The male factor in fertility and infertility. VI. Semen quality and certain activity in the spermatozoa of 1000 fertile men and 1000 men in infertile marriage.
Fertil. & Steril. 2 : 187, 1951.
- MACLEOD, J. and GOLD, R. Z.
The male factor in fertility and infertility. VI Semen quality and certain other factors in relation to ease of conception.
Fertil. and Steril. 4 : 10-33, 1953.
- MACLEOD, J. and GOLD, R. Z.
The male factor in fertility and infertility. VIII A study of variation in semen quality.
Fertil. and Steril. 7 : 389, 1956.

- MACLEOD, J. and HOTCHKISS, R. S.
The effect of hyperpyrexia upon spermatozoa counts in men.
Endocrinology 28 : 780-784, 1941.
- MACLEOD, J. and HOTCHKISS, R. S.
The distribution of spermatozoa and certain chemical constituents in the human ejaculate
J. Urol. 48, 225-229, 1942.
- MARCUS, S. L.
Observations on the origin of oviduct fluid in the rhesus monkey.
Proceedings of the fifth world congress of Fertility and Sterility, June 16-22, 1966 Stockholm, page 195-198. Excerpta Medica Foundation.
- MASTERS, W. H. and JOHNSON, V. E.
Intravaginal environment.
Fertil. and Steril. 12 : 560, 1961.
- MASTERS, W. H. and JOHNSON, V. E.
Human sexual response.
J. and A. Churchill Ltd. London; page 115, page 123, 1966.
- MILLER, E. G. and KURZROK, R.
Biochemical studies of human semen III. Factors affecting migration of sperm through the cervix.
Am. J. Obst. & Gynec. 24 : 19, 1932.
- MILLS, R. G.
The pathological changes in the testes in epidemic pneumonia.
J. Exp. Med. 30 : 505-529, 1919.
- MOENCH, G. L.
Variations of the solubility of the cervical mucus in relation to the menstrual cycle.
J. Lab. and Clin. Med. 19 : 358, 1934.
- MOGHISSI, K. S.
Human and Bovine Sperm Migration.
Fertil. and Steril. 19 : 118, 1968.
- MOGHISSI, K. S., DABICK, D., LEVINE, J. and NEUHAUS, O. W.
Mechanism of Sperm Migration.
Fertil. and Steril. 15 : 15, 1964.
- MOORE, C. R. and OSLUND, R.
Experiments on the sheep testis - cryptorchism, vasectomy and scrotal insulation.
Am. J. Physiol. 67 : 595, 1924.
- NAKABAYASHI, N. T., TYLER, E. T. and TYLER, A.
Immunologic aspects of human infertility.
Fertil. and Steril. 12 : 544, 1961.
- NELSON, W. O.
Interpretation of testicular biopsy.
J.A.M.A. 151 : 454, 1953.
- NELSON, W. O. and BUNGE, R. G.
The effect of therapeutic dosages of nitrofurantoin (furadantin) upon spermatogenesis in man,
J. Urol. 77 : 275-281, 1957.
- NEUHAUS, O. W. and MOGHISSI, K. S.
Composition and properties of human cervical mucus. III. A preliminary study of the mucoid component.
Fertil. and Steril. 13 : 550, 1962.
- NICKOLSON, R.
Vitality of spermatozoa in the endocervical canal.
Fertil. and Steril. 16 : 758, 1965.
- ODEBLAD, E.
The physics of cervical mucus.
Acta Obst. et Gyn. Scand. 38, Suppl. 1 : 44-58, 1958.

- OGINO, K.
 Ueber den Konzeptionstermin des Weibes und seine Anwendung in der Praxis.
 Zbl. Gynäk. 56 : 721-732, 1932.
- PALMER, A.
 Endocervical forceps for evaluation of the cervical factor in infertility.
 J.A.M.A. 158 : 1281, 1955.
- PAPANICOLAOU, G. N.
 A general survey of the vaginal smear and its use in research and diagnosis.
 Am. J. Obst. and Gynec. 51 : 316-328, 1946.
- PAPASOV, Br. und ENTSCHJEV, E. M.
 Nachweis von „Spermienantikörpern“ beim Weibe als Sterilitätsursache.
 Zentralblatt für Gynäkologie 85 : 1542, 1963.
- PERLOFF, W. H. and STEINBERGER, E.
 In vitro penetration of cervical mucus by spermatozoa.
 Fertil. and Steril. 14 : 231, 1963.
- PERLOFF, W. H. and STEINBERGER, E.
 In vivo survival of spermatozoa in cervical mucus.
 Am. J. Obst. and Gynec. 88 : 439, 1964.
- PHADKE, A. M. and PADUKONE, K.
 Presence and significance of autoantibodies against spermatozoa in the blood of men with obstructed vas deferens.
 J. Reprod. Fertil. 7 : 163, 1964.
- ROCK, J.
 Physiology of human conception.
 New Engl. J. Med. 240 : 804-812, 1949.
- ROLAND, M.
 A simple test for the determination of ovulation, estrogen activity and early pregnancy using the cervical mucus secretion.
 Am. J. Obst. Gynec. 63 : 81, 1952.
- ROLAND, M.
 The fern test. A critical analysis.
 Obstet. Gynec. 11 : 30-34, 1958.
- ROZIN, S.
 Studies on seminal plasma: I. The role of seminal plasma in motility of spermatozoa.
 Fertil. and Steril. 11 : 278, 1960.
- ROZIN, S.
 Studies on seminal plasma.
 Intern. J. Fertil. 6 : 169, 1961.
- ROZIN, S. and ROZIN, R.
 III. The influence of body fluids on motility of spermatozoa.
 Intern. J. Fertil. 7 : 327, 1962.
- RUBINSTEIN, B. B., STRAUSS, H., LAZARUS, M. and HANKIN, H.
 Sperm survival in women.
 Fertil. and Steril. 2 : 15, 1951.
- RUIZ-VELASCO, V.
 A quantitative spermatocidal penetration test.
 Intern. J. Fertil. 7 : 11, 1962.
- RüMKE, Ph.
 The presence of sperm antibodies in the serum of two patients with oligozoospermia.
 Vox Sang. 4 : 135, 1954.
- RüMKE, Ph. and HELLINGA, G.
 Auto-antibodies against spermatozoa in sterile men.
 Am. J. Clin. Path. 32 : 357-363, 1959.

- RUNGE, E.
Beitrag zur Aetiologie und Therapie der weiblichen Sterilität.
Arch. Gynäk. 87 : 572, 1909.
- RYDBERG, E.
Observations on the crystallization of cervical mucus.
Acta Obst. et Gynec. Scandinav. 28 : 172, 1948.
- SALVATIERRA, V. et SUREDA, G.
Le test de progression capillaire des spermatozoïdes et sa relation avec
les critères morphologiques de normalité spermatique.
Gynaecologia 146 : 31, 1958.
- SCHELLEN, A. M. C. M.
The cervical spoon for the diagnosis of sterility.
Int. J. Fertil. 5 : 311, 1960.
- SCHWARTZ, R. and ZINSSER, H.
Sperm motility: A simple method for analysis.
Am. J. Med. 17 : 124, 1954.
- SCHWARTZ, R. and ZINSSER, H.
Some factors modifying sperm progression.
Fertil. and Steril. 6 : 450, 1955.
- SCHUSTER, A.
Experimenteller Nachweis zweier voneinander abhängiger chemotaktischer
Systemen beim Transport der Spermien.
Arch. Gynäk. 187, 231, 1955.
- SCOTT, L. S. and YOUNG, D.
Varicocèle: A study of its effects on human spermatogenesis, and of the
results produced by spermatic vein ligation.
Fertil. and Steril. 13 : 325, 1962.
- SCOTT BLAIR, G. W. and GLOVER, F. A.
Consistometer for the study of consistency of cervical mucus and other
biological fluids.
In Flow properties of blood and other biological systems, edited by A. L.
Copley and G. Stainsby, Pergamon Press.
- SEELIGMANN, L.
Weitere Mitteilungen für Behandlung der Sterilitas matrimonii.
Zentral bl. f. Gynäk. 20 : 429, 1896.
- SEGUY, J. and SIMONNET, H.
Recherche de signes directs d'ovulation chez la femme.
Gynec. Obstét. 28 : 657-663, 1933.
- SEGUY, J. and VIMEUX, J.
Contribution a l'étude des stérilités inexpliquées. Etude de l'ascension des
spermatozoïdes dans les vois génitales basses de la femme.
Gynec. Obstét. 27 : 346-358, 1933.
- SILLO-SEIDL, G.
Die Bewegungslehre der menschlichen Samenfäden.
S. Karger Verlag, Basel-New York, 1963.
- SIMMONS, F. A.
Clinical interpretation of the semen analysis.
In: Conference on Diagnosis in Sterility, pp. 16-31 E.T. Engle (ed.). Charles
C. Thomas, Springfield, Ill. 1946.
- SIMS, J. M.
Clinical Notes on Uterine Surgery.
New York 1866, W. Wood.
- SMITH, S. E. and NEUMAN, R.
A qualitative method of determining motility of sperm.
Fertil. and Steril. 12 : 486, 1961.

- SOBRERO, A. J.
Sperm migration in the female genital tract. In Hartman, C. G. Mechanisms concerned with conception.
Pergamon Press, New York-London 1963, pp. 173-203.
- SOBRERO, A. J.
Sperm migration in the human female.
Proceedings of the fifth World Congress of Fertility and Sterility June 16-22, 1966, Stockholm, page 701-703. Excerpta Medica Foundation.
- SOBRERO, A. J. and MAC LEOD, J.
The immediate post coital test.
Fertil. and Steril. 13 : 184, 1962.
- SOUTHAM, A. L. and BUXTON, L.
Seventy postcoital tests made during the conception cycle.
Fertil. and Steril. 7 : 133, 1956.
- STRASSMANN, P.
Vordringen der Spermien.
In Winkel's Handbuch der Geburtshilfe, vol. 1, Part 1, Wiesbaden, p. 154, 1903.
- TAMPION, D. and GIBBONS, R. A.
Orientation of spermatozoa in mucus of the cervix uteri.
Nature 194, 381, 1962a.
- TIETZE, C.
Probability of pregnancy resulting from a single unprotected coitus.
Fertil. and Steril. 11 : 485, 1960.
- TYLER, E. T.
The vagina and fertility.
Ann. N.Y. Acad. Sci. 83 : 294, 1959.
- VASTERLING, H. W.
Practische Spermatologie, ein Leitfaden für Aerzte.
Georg Thieme Verlag - Stuttgart 1960.
- VIERGIVER, E. and POMMERENKE, W. T.
Measurement of the cyclic variations in the quantity of cervical mucus and its correlation with basal temperature.
Am. J. Obst. and Gynec. 48 : 321-328, 1944.
- VOLLMANN, R. F.
Ueber Fertilität und Sterilität der Frau innerhalb des Menstruationscyclus.
Arch. Gynäk. 182 : 602-622, 1953.
- VOLLMANN, U.
Untersuchungen über die Körpertemperatur der Frau in Korrelation zu den Phasen ihres Genetalzyklus.
Mschr. Geburtsh. Gynäk. 111 : 41-62; 121-153, 1940.
- WEISMAN, A. I.
A technique for aspirating viable spermatozoa from the cavity of the uterus as a further study in sperm behavior.
Am. J. Obst. and Gynec. 39 : 875, 1940.
- WERNER, I.
The chemistry of cervical mucus.
Acta obst. et gynec. Scandinav. 38 : 39; Suppl. 1, 1959.
- WILLIAMS W. W. and SIMONS, F. A.
The intracervical survival of spermatozoa.
Am.J. Obst. and Gynec. 43 : 652-662, 1942.
- WILSON, L.
Sperm agglutinins in human semen and blood.
Proc. Soc. Exper. Biol. and Med. 85, 652-655, 1954.

TABLE 1. Influence of temperature on the results of the SPM test using blood serum (blood group AB, Rh +) as penetration medium and semen of varying quality.

No.	Properties of the semen			Results of the SPM test at room temperature				Results of the SPM test at 37° C.				Results of the SPM test at 40° C.			
	Spermatozoal density in millions/cc	Spermatozoal motility		Depth of penetration after 30 minutes	No. of spermatozoa per L.P.F. after 2 hours at 5 cm	Qualitative motility of spermatozoa after 2 hours at 5 cm	Duration of motility of the spermatozoa	Depth of penetration after 30 minutes	No. of spermatozoa per L.P.F. after 2 hours at 5 cm	Qualitative motility of spermatozoa after 2 hours at 5 cm	Duration of motility of the spermatozoa	Depth of penetration after 30 minutes	No. of spermatozoa per L.P.F. after 2 hours at 5 cm	Qualitative motility of spermatozoa after 2 hours at 5 cm	Duration of motility of the spermatozoa
		quant.	qual.												
1	175.10 ⁶	40 %	3+	6 cm	10-20	3—	>144<168 hrs.	≡6 cm	20-50	3—	>72<96 hrs.	≡6 cm	20-50	3—	>48<72 hrs.
2	210.10 ⁶	40 %	3+	2½ cm	0	-	>120<144 "	≡2½ cm	10-20	2+	>72<96 "	3 cm	10-20	2+	>48<72 "
3	190.10 ⁶	70 %	3+	5 cm	5-10	3—	>144<168 "	≡6 cm	20-50	3—	>96<120 "	≡6 cm	10-20	3—	>48<72 "
4	28.10 ⁶	30 %	2	2 cm	0	-	>96<120 "	≡4 cm	0-5	2	>72<96 "	≡4 cm	0-5	2	>24<48 "
5	87.10 ⁶	60 %	3	5½ cm	5-10	3—	>144<168 "	≡6 cm	10-20	3—	>120<144 "	≡6 cm	10-20	2+	>48<72 "
6	160.10 ⁶	40 %	3+	3 cm	0-5	3	>144<168 "	≡6 cm	10-20	3	>72<96 "	≡6 cm	10-20	3—	>48<72 "
7	135.10 ⁶	60 %	3+	3½ cm	0-5	3	>168<192 "	≡6 cm	20-50	3	>72<96 "	≡6 cm	20-50	3—	>48<72 "
8	120.10 ⁶	60 %	3+	4½ cm	0-5	3—	>192<216 "	≡6 cm	20-50	3—	>120<144 "	≡6 cm	50-100	3—	>48<72 "

TABLE 2. Comparative investigation of the results of the SPM test (at 37° C) using an isotonic glucose-saline solution, a colloidal plasma substitute, a pasteurized solution of human plasma protein or fresh human blood serum as penetration medium.

Nature of the penetration medium	Depth of penetration after 30 minutes	Density of penetration after 2 hours at 5 cm	Duration of motility of spermatozoa
Glucose-saline solution	1 cm	-	8-24 hours
Colloidal plasma substitute	1½ cm	-	8-24 hours
Pasteurized solution of human plasma protein	2 cm	-	8-24 hours
Fresh blood serum (AB, Rh +)	3½ cm	10-20	48-72 hours

TABLE 3. Results of the SPM test using normal cervical mucus from the ovulation period and semen of varying quality.

Total 135 couples.

No.	Properties of the cervical mucus important for spermatozoal transport					Properties of the semen important for spermatozoal transport				Results of the SPM test								Fertility assessment of the semen	Result of the SPM test					
	Clarity	Viscosity	Spinnbarkeit	pH	Glucosetest	Ferntest	Sperm density in millions per cc	Motility at commencement of test %	gr	% normal headforms	Penetration density and qualitative motility after two hours at:						Qualitative motility of the spermatozoa after:							
											Depth of penetration in cm after:		1 cm		3 cm		5 cm							
											30 min.	2 hrs.	density	motility	density	motility	density			motility	8 hrs	24 hrs	48 hrs	72 hrs
1	I	1	40	8.1	neg.	++++	<1.10 ⁶	sp.	1	57	0	1	0-5	2-	0	-	0	-	1	1-	1-	0	bad	bad
2	I	1.3	35	8.1	neg.	++++	<1.10 ⁶	sp.	3	48	0	3	0	-	sp.	1	0	-	1-	1-	0	0	poor	bad
3	I	1.5	30	7.5	neg.	++++	<1.10 ⁶	sp.	<1	20	1/2	1/2	0	-	0	-	0	-	0	0	0	0	bad	bad
4	I	2.6	30	7.5	neg.	++++	<1.10 ⁶	sp.	1+	35	0	1	sp.	1	0	-	0	-	0	0	0	0	bad	bad
5	II	2	40	7.5	neg.	++++	<1.10 ⁶	sp.	1	70	0	1	sp.	0	0	-	0	-	0	0	0	0	poor	bad
6	I	2	35	7.8	neg.	++++	<1.10 ⁶	sp.	1	42	0	0	0	-	0	-	0	-	2-	0	0	0	bad	neg.
7	II	1.2	40	7.5	neg.	++++	<1.10 ⁶	sp.	2	45	0	0	0	-	0	-	0	-	0	0	0	0	bad	neg.
8	I	1	100	7.5	++	++++	4.10 ⁶	40	2+	56	1	1	0-5	1	0	-	0	-	<1	0	0	0	poor	bad
9	II	2.3	70	7.8	neg.	++++	4.10 ⁶	sp.	1	48	0	2	sp.	1	0	-	0	-	<1	0	0	0	bad	bad
10	I	1.4	150	8.3	trace	++++	4.10 ⁶	40	2+	51	2 1/2	3	50-100	<1	20	<1	0	-	<1	0	0	0	poor	bad
11	I	1.7	45	8.1	+	++++	5.10 ⁶	sp.	1+	70	5	5	20-50	2	0-5	2-	0-5	1-	1-	0	0	0	poor	poor
12	I	1.2	45	7.5	+	++++	5.10 ⁶	sp.	2	44	4	4 1/2	20-50	2-	sp.	1-	0	-	1-	1	0	0	poor	poor
13	II	1.4	50	8.3	+	++++	6.10 ⁶	40	2	38	4	5	0-5	2	0-5	2	0-5	1+	<1	0	0	0	poor	fair
14	I	1.4	80	8.1	trace	++++	7.10 ⁶	sp.	1+	36	1 1/2	4	sp.	<1	sp.	<1	0	-	<1	0	0	0	bad	poor
15	I	1.2	40	8.1	+++	++++	7.10 ⁶	10	1+	42	1	1	sp.	<1	0	-	0	-	<1	0	0	0	poor	bad
16	I	1.4	40	6	neg.	++++	7.10 ⁶	20	3	53	4	6	20-50	2+	0-10	2-	0-5	2	2	1	1	0	poor	fair
17	I	2.2	60	8.3	+	++++	7.10 ⁶	sp.	1+	49	0	1/2	0	-	0	-	0	-	0	0	0	0	bad	bad
18	I	1.4	60	8.1	+	++++	7.10 ⁶	10	1+	45	1 1/2	1 1/2	sp.	<1	0	-	0	-	<1	0	0	0	poor	bad
19	II	1.7	35	7.2	neg.	++++	8.10 ⁶	10	2+	52	1/2	1	0-5	2-	0	-	0	-	1+	0	0	0	poor	bad
20	II	3.7	35	8.3	++	++++	9.10 ⁶	40	2+	61	4	4	5-10	0	sp.	0	0	-	0	0	0	0	poor	bad
21	I	0.8	80	7.2	neg.	++++	10.10 ⁶	30	2-	46	6	6	10-20	2+	sp.	<1	0-5	2+	1-	0	0	0	poor	fair
22	I	1.4	40	8.1	trace	++++	10.10 ⁶	70	3+	50	6	6	10-20	2	0-5	2	0-5	2	2	0	0	0	passable	fair
23	I	3	30	8	neg.	++++	10.10 ⁶	20	2+	45	1	1	10-20	1	0	-	0	-	1	<1	0	0	poor	bad
24	II	3.2	40	7.8	neg.	++++	10.10 ⁶	sp.	1	50	1	2	0-5	1	0	-	0	-	<1	<1	0	0	poor	bad
25	I	3.8	40	8.3	neg.	++++	11.10 ⁶	30	3-	40	1 1/2	2	10-20	1	0	-	0	-	<1	<1	0	0	poor	bad
26	I	0.8	35	8	+	++++	11.10 ⁶	10	2+	48	5	6	5-10	1	0-5	1	sp.	1	1	1	1	1-	poor	poor
27	I	1.7	35	7.2	neg.	++++	11.10 ⁶	30	3	52	5	5 1/2	20-50	1	0-10	1+	sp.	3	1-	1	0	0	poor	fair
28	I	1	100	7.5	++	++++	11.10 ⁶	30	3-	46	2	2	10-20	1	0	-	0	-	<1	<1	0	0	poor	bad
29	II	1.2	40	7.8	neg.	++++	12.10 ⁶	30	3+	57	0	2	0-5	1	0	-	0	-	1-	0	0	0	poor	bad
30	I	2.2	60	8	+	++++	12.10 ⁶	20	2+	48	1/2	2 1/2	5-10	1	0	-	0	-	2	<1	<1	0	poor	bad
31	II	2.2	30	7.2	neg.	++++	13.10 ⁶	5	1+	46	1	1	0-5	1-	0	-	0	-	1-	1-	1-	0	bad	bad
32	II	1.9	35	8.1	+	++++	13.10 ⁶	5	2-	62	1 1/2	3	20-50	1	sp.	1	0	-	1-	1	1	1-	poor	bad
33	I	1.4	45	8.1	neg.	++++	13.10 ⁶	5	1+	32	3 1/2	5 1/2	5-10	2-	0-5	1+	sp.	1+	1-	0	0	0	bad	fair
34	II	3.7	30	7.5	neg.	++++	13.10 ⁶	sp.	1	36	1 1/2	1 1/2	sp.	<1	0	-	0	-	0	0	0	0	bad	bad
35	II	0.7	40	8.1	neg.	++++	13.10 ⁶	20	2+	60	2 1/2	5	20-50	2+	sp.	3	sp.	3	2	1+	0	0	poor	fair
36	II	1	55	8.1	++	++++	14.10 ⁶	sp.	1+	61	0	3	5-10	1-	sp.	2	0	-	1-	1-	0	0	poor	bad
37	I	2	90	8.1	+	++++	15.10 ⁶	sp.	1	46	0	0	0	-	0	-	0	-	0	0	0	0	bad	neg.
38	I	2	30	8.1	+	++++	16.10 ⁶	5	1	50	1	3	0-5	1-	sp.	1-	0	-	1-	0	0	0	poor	bad
39	I	1.8	35	8.1	neg.	++++	18.10 ⁶	10	3-	46	4 1/2	5	0-5	2+	sp.	3	sp.	1-	2+	1-	0	0	poor	poor
40	I	2.7	35	8.2	neg.	++++	19.10 ⁶	10	2+	45	5	5 1/2	20-50	1-	20-50	1+	sp.	1-	1+	1-	0	0	poor	poor
41	I	1.1	70	8.1	neg.	++++	20.10 ⁶	60	3-	52	6	6	20-50	1-	10-20	1+	5-10	2	1	1-	1-	0	passable	fair
42	II	2.2	35	8.1	+	++++	22.10 ⁶	sp.	1	40	0	0	0	-	0	-	0	-	0	0	0	0	poor	neg.
43	I	1.1	45	8.1	neg.	++++	23.10 ⁶	40	3+	62	3 1/2	5 1/2	20-50	2+	10-20	2+	10-20	3-	<1	<1	1	<1	passable	fair
44	I	3.5	40	7.8	trace	++++	24.10 ⁶	70	3+	64	3	3 1/2	5-10	1	0-5	<1	0	-	<1	<1	0	0	good	poor
45	I	1.4	30	8.1	neg.	++++	25.10 ⁶	60	3+	56	6	6	20-50	2+	20-50	3-	10-20	3-	2-	1	0	0	passable	good
46	I	0.8	80	7.8	neg.	++++	25.10 ⁶	70	3+	72	5	5 1/2	50-100	2+	20-50	2+	0-10	2	1+	1+	1-	1-	good	fair
47	I	1.4	40	7.2	neg.	++++	25.10 ⁶	40	3+	62	4	5	20-50	1+	10-20	1+	5-10	1+	1+	1	1-	0	passable	fair
48	II	1.1	40	8.1	++	++++	26.10 ⁶	40	2+	76	4	5	20-50	2+	0-10	2	0-5	2	1	1-	1	0	passable	fair
49	I	1.4	35	8.1	neg.	++++	26.10 ⁶	60	3+	60	3	6	20-50	2	10-20	2+	0-10	2	2+	1	0	0	good	fair
50	I	1.4	70	7.5	neg.	++++	27.10 ⁶	30	2	36	6	6	20-50	1+	10-20	2	5-10	1+	1+	1	0	0	poor	fair
51	I	1.7	90	7.8	neg.	++++	27.10 ⁶	10	2-	58	1	1 1/2	0-5	1	0	-	0	-	0	0	0	0	poor	bad
52	I	1.1	40	7.5	neg.	++++	28.10 ⁶	70	3+	60	6	6	20-50	3-	20-50	3+	0-10	3+	2+	2+	1	0	good	fair
53	I	0.8	70	8.4	neg.	++++	29.10 ⁶	20	2+	51	6	6	20-50	1+	20-50	1+	10-20	2+	2-	1	0	0	poor	good

TABLE 3. - Continued.

No.	Properties of the cervical mucus important for spermatozoal transport						Properties of the semen important for spermatozoal transport				Results of the SPM test								Fertility assessment of the semen	Result of the SPM test											
	Clarity	Viscosity	Spinnbarkeit	pH	Glucosetest	Ferment	Sperm density in millions per cc	Motility at commencement of test %	gr	% normal headforms	Penetration density and qualitative motility after two hours at:						Qualitative motility of the spermatozoa after:														
											Depth of penetration in cm after:		1 cm		3 cm		5 cm														
30 min.	2 hrs.	density	motility	density	motility	density	motility	8 hrs	24 hrs	48 hrs	72 hrs																				
54	I	1.2	90	8.3	neg.	+++	29.10 ⁶	60	3+	60	6	6	20-50	1	10-20	<1	5-10	1	<1	0	0	0	0	good	fair						
55	I	2	70	8.3	trace	+++	30.10 ⁶	30	2+	50	3 1/2	3 1/2	10-20	1	0-5	1	0	-	1	0	0	0	0	0	poor	poor					
56	I	1.4	30	8.1	neg.	+++	31.10 ⁶	60	3+	59	6	6	50-100	2+	20-50	3-	20-50	3-	1-	0	0	0	0	0	passable	fair					
57	I	0.8	45	7.8	neg.	+++	33.10 ⁶	60	3+	56	6	6	>500	3+	50-100	3+	20-50	3+	3	2+	1-	1-	1-	1-	passable	excellent					
58	I	2.8	80	7.8	neg.	+++	33.10 ⁶	40	3+	46	6	6	20-50	2	20-50	2+	20-50	2+	3-	1+	0	0	0	0	0	passable	good				
59	I	1.7	30	8.1	++	+++	34.10 ⁶	40	3+	44	6	6	20-50	2-	20-50	3-	10-20	3-	3+	2-	1-	0	0	0	0	poor	good				
60	II	1.4	55	7.8	neg.	+++	35.10 ⁶	70	3+	56	4 1/2	5 1/2	100-200	2+	20-50	2+	10-20	2-	1+	1-	0	0	0	0	0	passable	fair				
61	I	2.6	40	8.3	trace	+++	37.10 ⁶	40	4	59	1 1/2	5	5-10	3+	0-5	4	0-5	4	1	1	0	0	0	0	0	good	fair				
62	I	1.4	35	7.2	neg.	+++	39.10 ⁶	50	3+	64	6	6	100-200	1-	50-100	1	50-100	3+	2+	0	0	0	0	0	0	passable	fair				
63	I	2	35	7.2	neg.	+++	39.10 ⁶	40	3+	50	3 1/2	5 1/2	50-100	2	20-50	2+	10-20	1+	2+	2-	1	1-	1-	1-	1-	passable	fair				
64	I	1.9	60	7.8	+	+++	40.10 ⁶	sp.	1+	30	0	0	0	-	0	-	0	-	0	0	0	0	0	0	0	poor	neg.				
65	II	3.3	40	7.8	neg.	+++	41.10 ⁶	80	3+	65	0	3	20-50	1-	sp.	1-	0	-	1-	1-	0	0	0	0	0	0	good	bad			
66	II	2	45	8.1	neg.	+++	42.10 ⁶	sp.	1	71	0	1	0-5	2+	0	-	0	-	2-	1	0	0	0	0	0	0	poor	bad			
67	II	2	30	8.1	neg.	+++	44.10 ⁶	30	3+	48	4 1/2	4 1/2	0-5	1-	sp.	1	0	-	1-	0	0	0	0	0	0	0	poor	poor			
68	I	1.7	90	7.8	trace	+++	46.10 ⁶	10	3+	46	4 1/2	5	50-100	1	10-20	3	0-5	4	2	2+	2	1	1	1	1	1	poor	fair			
69	II	2.5	45	8.1	neg.	+++	48.10 ⁶	70	3+	62	3 1/2	5 1/2	50-100	2+	20-50	2+	5-10	1	3-	1-	1-	1-	1-	1-	1-	1-	good	fair			
70	I	1.7	80	8.3	+	+++	50.10 ⁶	40	2+	56	6	6	10-20	2+	5-10	2+	0-5	2	1+	0	0	0	0	0	0	0	passable	fair			
71	I	2.4	30	8.1	neg.	+++	51.10 ⁶	60	3+	57	6	6	50-100	2+	20-50	3+	20-50	2+	2	0	0	0	0	0	0	0	passable	fair			
72	I	1.9	40	8.1	neg.	+++	54.10 ⁶	40	3+	70	6	6	100-200	3+	50-100	3+	20-50	2+	2-	2-	2	0	0	0	0	0	0	good	good		
73	I	2.3	70	8.1	+	+++	54.10 ⁶	50	3+	56	6	6	>200	3-	>200	2+	100-200	2-	2-	<1	0	0	0	0	0	0	0	passable	fair		
74	I	1.7	30	8.1	+	+++	55.10 ⁶	5	1+	73	2	3	0-5	1-	sp.	1-	0	-	2	2	0	0	0	0	0	0	0	poor	bad		
75	II	1.4	35	8.1	trace	+++	55.10 ⁶	40	3+	55	2 1/2	5	20-50	2-	5-10	1+	0-5	1	2+	2-	1-	0	0	0	0	0	0	passable	fair		
76	I	1.6	35	8.1	neg.	+++	58.10 ⁶	50	3+	69	5	6	50-100	2+	20-50	2	20-50	3+	2	0	0	0	0	0	0	0	0	passable	fair		
77	II	1.7	30	7.5	neg.	+++	58.10 ⁶	40	4+	69	6	6	>200	2-	50-100	2+	20-50	2+	2+	1	1-	0	0	0	0	0	0	good	good		
78	I	1.4	60	8.3	+	+++	60.10 ⁶	20	2+	61	5	6	50-100	1	20-50	1	10-20	1+	2	<1	0	0	0	0	0	0	0	passable	fair		
79	I	2.6	80	7.2	neg.	+++	60.10 ⁶	30	3+	56	6	6	20-50	2-	5-10	2+	sp.	1	2+	1+	1-	1	1	1	1	1	1	passable	fair		
80	II	3	45	8.1	neg.	+++	61.10 ⁶	40	3+	67	4	5	>200	1-	20-50	2	5-10	2-	1	0	0	0	0	0	0	0	0	good	fair		
81	II	3	100	7.8	neg.	+++	61.10 ⁶	60	3+	67	2	3	100-200	1+	0-5	1	0	-	<1	0	0	0	0	0	0	0	0	good	bad		
82	I	1.4	75	8.1	neg.	+++	64.10 ⁶	50	3+	71	6	6	20-50	3	20-50	3	10-20	3	3	0	0	0	0	0	0	0	0	good	fair		
83	I	1.7	50	7.8	neg.	+++	66.10 ⁶	70	3+	69	1 1/2	3	20-50	1	0-5	1	0	-	1-	1-	0	0	0	0	0	0	0	good	bad		
84	II	1.6	30	7.5	neg.	+++	66.10 ⁶	60	3+	74	6	6	50-100	3+	20-50	3+	20-50	3+	1	1	1	1	1	1	1	1	1	good	excellent		
85	I	2.8	40	8.1	trace	+++	68.10 ⁶	60	3+	72	1	5	100-200	2+	50-100	3+	20-50	3+	.	1	0	0	0	0	0	0	0	good	fair		
86	II	3	30	7.2	neg.	+++	69.10 ⁶	30	3-	61	4	5	20-50	2-	sp.	2	sp.	1	2	1	0	0	0	0	0	0	0	passable	fair		
87	I	2.8	130	8.1	neg.	+++	70.10 ⁶	20	3-	54	0	2	0-5	1+	0	-	0	-	1	0	0	0	0	0	0	0	0	poor	bad		
88	I	1.7	40	8.1	+	+++	75.10 ⁶	50	3+	55	6	6	100-200	2-	20-50	2+	10-20	2+	1-	1-	1-	0	0	0	0	0	0	passable	good		
89	I	1.9	70	8.1	+	+++	76.10 ⁶	30	3+	65	0	0	0	-	0	-	0	-	0	0	0	0	0	0	0	0	0	good	neg.		
90	I	2	85	8.1	neg.	+++	77.10 ⁶	80	4+	77	6	6	100-200	1+	20-50	1+	20-50	1+	1+	1-	0	0	0	0	0	0	0	0	good	fair	
91	I	1.4	30	8.1	neg.	+++	79.10 ⁶	40	3+	66	6	6	>200	1	100-200	1	50-100	2	1-	1-	<1	0	0	0	0	0	0	0	good	good	
92	II	1.6	30	8.1	+	+++	80.10 ⁶	80	3+	74	4	5	50-100	2+	20-50	3+	20-50	3+	2	1-	1-	0	0	0	0	0	0	0	good	fair	
93	II	2.7	35	8.1	neg.	+++	81.10 ⁶	sp.	1	67	3	5 1/2	20-50	2-	0-5	2-	sp.	2+	2-	0	0	0	0	0	0	0	0	poor	fair		
94	II	1	30	7.8	neg.	+++	84.10 ⁶	70	3+	62	6	6	50-100	2	20-50	2+	20-50	2+	3-	0	0	0	0	0	0	0	0	0	good	fair	
95	I	2	90	8.1	+	+++	85.10 ⁶	60	3+	65	6	6	50-100	1	100-200	1+	100-200	1+	1	<1	<1	0	0	0	0	0	0	0	good	fair	
96	I	1	35	7.5	neg.	+++	85.10 ⁶	80	3+	78	6	6	100-200	2+	50-100	2+	50-100	2-	1-	1-	0	0	0	0	0	0	0	0	good	fair	
97	II	1.6	55	8.1	++	+++	88.10 ⁶	50	3+	68	6	6	50-100	1	20-50	1	10-20	2	2	<1	2	2-	0	0	0	0	0	0	good	good	
98	II	1.5	40	8.1	neg.	+++	90.10 ⁶	sp.	1+	65	1 1/2	6	20-50	2+	20-50	2+	sp.	3	3+	1+	<1	0	0	0	0	0	0	poor	fair		
99	II	1	30	8.1	neg.	+++	91.10 ⁶	70	3+	71	6	6	>200	1-	50-100	2	20-50	2	2	<1	0	0	0	0	0	0	0	0	good	good	
100	II	2	40	7.2	++	+++	92.10 ⁶	10	2+	68	1	3 1/2	20-50	1-	0-5	1-	0	-	1-	1-	1-	0	0	0	0	0	0	0	passable	poor	
101	I	3	35	6.6	neg.	+++	97.10 ⁶	10	1+	72	3 1/2	6	200	2+	20-50	2-	20-50	2	2-	1	1-	0	0	0	0	0	0	0	passable	fair	
102	II	3.3	30	7.8	trace	+++	100.10 ⁶	40	2+	67	3	5	>200	2	20-50	2+	5-10	2-	2	2-	1-	1-	0	0	0	0	0	0	passable	fair	
103	I	2	40	7.8	trace	+++	103.10 ⁶	40	2+	70	0	3 1/2	100-200	2-	0-10	1	0	-	1+	1-	<1	0	0	0	0	0	0	0	good	poor	
104	I	1.7	90	8.3	trace	+++	105.10 ⁶	30	3+	64	1	3	0-5	<1	0-5	<1	0	-	<1	0	0	0	0	0	0	0	0	0	passable	bad	
105	II	2.6	30	8.1	+	+++	108.10 ⁶	30	3-	0	6	6	50-100	2	20-50	2+	10-20	2	2	2+	2+	1	1	1	1	1	1	1	poor	good	
106	I	0.8	30	7.5	neg.	+++	110.10 ⁶	60	3+	73	6	6	>200	2-	100-200	2+	20-50	3+	2+	2-	1+	2-	0	0	0	0	0	0	0	good	excellent

TABLE 3. - Continued.

No.	Properties of the cervical mucus important for spermatozoal transport						Properties of the semen important for spermatozoal transport				Results of the SPM test								Fertility assessment of the semen	Result of the SPM test				
	Clarity	Viscosity	Spinnbarkeit	pH	Glucosetest	Ferntest	Sperm density in millions per cc	Motility at commencement of test %	% normal headforms	Penetration density and qualitative motility after two hours at:				Qualitative motility of the spermatozoa after:										
										Depth of penetration in cm after:		1 cm		3 cm		5 cm		8 hrs			24 hrs		48 hrs	
107	I	1.6	30	7.8	neg.	++++	114.10 ⁶	80	3+	71	6	6	100-200	3+	20-50	3-	0-5	2	2+	3-	2-	1+	good	fair
108	II	2	35	8.1	++	++++	115.10 ⁶	40	3+	75	5 ^{1/2}	6	100-200	1-	50-100	3+	20-50	3+	3+	1+	1	1	good	good
109	I	2	55	7.3	+	++++	127.10 ⁶	80	3+	77	6	6	>200	2+	>200	3-	100-200	4	2	1	1	1	good	excellent
110	I	2	30	7.5	neg.	++++	128.10 ⁶	10	2+	68	3	5	20-50	2-	20-50	2+	5-10	2+	1	1-	0	0	passable	fair
111	I	1.7	65	7.5	neg.	++++	130.10 ⁶	50	3+	62	5	6	>200	1	50-100	3-	50-100	3+	<1	<1	0	0	good	good
112	I	1.7	65	7.5	neg.	++++	130.10 ⁶	50	3+	62	5	6	>200	1	50-100	3-	50-100	3+	1	<1	0	0	good	good
113	II	1.6	30	8.1	neg.	++++	134.10 ⁶	40	3+	66	6	6	20-50	3-	20-50	3+	20-50	3+	2	1+	0	0	good	good
114	II	1.1	45	7.2	neg.	++++	140.10 ⁶	70	3+	76	6	6	>200	1-	100-200	2-	50-100	3-	2-	1-	1-	1	good	good
115	I	1	55	7.2	neg.	++++	144.10 ⁶	80	4+	72	6	6	>200	1-	100-200	1+	50-100	1+	1+	1-	1-	0	good	fair
116	I	1	30	8.1	neg.	++++	147.10 ⁶	40	3+	74	5	6	100-200	1-	20-50	2+	20-50	2+	1-	1-	0	0	good	good
117	I	0.8	40	7.5	+	++++	150.10 ⁶	70	3+	70	6	6	20-50	3-	20-50	3+	20-50	3+	3-	1	0	0	good	good
118	I	2	55	7.5	neg.	++++	160.10 ⁶	70	4+	70	6	6	>200	1-	100-200	1+	20-50	2-	1+	1	0	0	good	fair
119	II	1.5	40	7.2	+	++++	160.10 ⁶	60	3+	65	6	6	100-200	2+	50-100	3+	20-50	2+	2+	2-	1-	1-	good	good
120	II	1	35	7.5	trace	++++	169.10 ⁶	40	3+	69	6	6	50-100	1+	50-100	3+	20-50	4-	3+	2+	0	0	good	good
121	I	1.5	50	8.1	neg.	++++	175.10 ⁶	20	1+	42	4 ^{1/2}	6	20-50	2-	20-50	2	10-20	2-	2-	1+	1-	0	poor	fair
122	II	1.5	45	8.1	+	++++	180.10 ⁶	40	3+	77	6	6	>200	1+	50-100	2	20-50	2+	1	1	1	0	good	good
123	II	3.8	55	8.1	neg.	++++	184.10 ⁶	5	2+	65	0	1	0-5	1+	0	-	0	-	1	0	0	0	passable	bad
124	I	0.8	40	7.5	neg.	++++	185.10 ⁶	40	3+	52	6	6	100-200	1-	50-100	1+	20-50	2+	2+	1	0	0	passable	good
125	I	1.7	75	8.1	++	++++	193.10 ⁶	70	3+	76	6	6	>200	1	100-200	1	20-50	3+	2+	1+	1	<1	good	excellent
126	I	1.4	35	7.8	neg.	++++	196.10 ⁶	70	3+	78	5	6	>200	2	>200	1	>200	1	<1	1	0	0	good	fair
127	I	0.8	40	7.5	neg.	++++	197.10 ⁶	80	4+	86	6	6	50-100	2-	20-50	1	20-50	1	<1	1-	0	0	good	fair
128	I	1.4	150	8.3	trace	++++	>200.10 ⁶	50	2	72	4	6	>200	1	>200	3-	50-100	3+	<1	1	0	0	good	fair
129	I	2.2	60	8.3	neg.	++++	>200.10 ⁶	60	3+	70	2	5	50-100	2	10-20	2	5-10	1+	<1	1	0	0	good	fair
130	I	1.7	60	8.1	neg.	++++	206.10 ⁶	70	3+	72	2	5	50-100	2+	20-50	2-	sp.	<1	2-	1-	0	0	good	poor
131	I	1	55	7.2	neg.	++++	215.10 ⁶	40	3+	65	6	6	>200	2+	100-200	3-	100-200	3+	2+	1-	1	1-	good	excellent
132	I	2.1	35	8.1	+	++++	270.10 ⁶	40	4-	74	6	6	100-200	3-	50-100	3+	20-50	3+	2-	3-	1	0	good	excellent
133	I	1.6	50	7.8	+	++++	304.10 ⁶	40	3+	59	6	6	>200	1-	>200	1-	100-200	2-	2-	1-	1-	1-	passable	fair
134	II	1.4	45	7.2	neg.	++++	355.10 ⁶	40	4-	73	5 ^{1/2}	6	100-200	2-	50-100	3-	0-5	2+	2-	2-	1+	1-	good	fair
135	II	2	35	7.2	neg.	++++	478.10 ⁶	70	4+	65	6	6	>200	2	100-200	3+	20-50	3-	1+	1-	1-	0	good	good

TABLE 3a. Relationship between the spermatozoal density in the semen of the husband and the result of the S P M test in 135 couples. The physico-chemical properties of the cervical mucus of the wife were favourable for penetration, migration and survival of spermatozoa.

Spermatozoal density per cc ejaculate	No. of cases	Result of the S P M test											
		negative		positive									
		number	%	bad		poor		fair		good		excellent	
number	%			number	%	number	%	number	%	number	%		
1. azoöpermia													
2. <5 million	10	2	20 %	8	80 %								
3. 5-20 million	30	1	3 %	16	54 %	6	20 %	7	23 %				
4. 20-60 million	37	2	5 %	4	11 %	3	8 %	21	57 %	6	16 %	1	3 %
5. \geq 60 million	58	1	2 %	5	9 %	3	5 %	26	45 %	17	29 %	6	10 %
Total	135	6	4 %	33	25 %	12	9 %	54	40 %	23	17 %	7	5 %

TABLE 3b. Relationship between the quantitative motility of the spermatozoa in the semen of the husband and the result of the S P M test in 135 couples. The physico-chemical properties of the cervical mucus of the wife were favourable for penetration, migration and survival of spermatozoa.

Quantitative motility of the spermatozoa	No. of cases	Result of the S P M test											
		negative		positive									
		number	%	bad		poor		fair		good		excellent	
number	%			number	%	number	%	number	%	number	%		
1. 0													
2. <5 %	21	5	24 %	11	52 %	3	14 %	2	10 %				
3. 5-40 %	39	1	3 %	16	41 %	6	15 %	14	36 %	2	5 %		
4. 40-60 %	37			3	8 %	1	3 %	16	43 %	15	41 %	2	5 %
5. \geq 60 %	38			3	8 %	2	5 %	22	58 %	6	16 %	5	13 %
Total	135	6	4 %	33	25 %	12	9 %	54	40 %	23	17 %	7	5 %

TABLE 3c. Relationship between the qualitative motility of the spermatozoa in the semen of the husband and the result of the S P M test in 135 couples. The physico-chemical properties of the cervical mucus of the wife were favourable for penetration, migration and survival of spermatozoa.

Qualitative motility of the spermatozoa	No. of cases	Result of the S P M test													
		negative		positive											
		number	%	bad	poor	fair	good	excellent	number	%	number	%			
1. Less than 1	1			1	100 %										
2. 1, 1+, 2—	28	4	14 %	16	57 %	2	7 %	6	22 %						
3. 2, 2+, 3—	31	1	3 %	10	32 %	7	23 %	11	36 %	2	6 %				
4. 3, 3+	66	1	1 %	6	9 %	3	5 %	31	47 %	19	29 %	6	9 %		
5. 4— or more	9							6	67 %	2	22 %	1	11 %		
Total	135	6	4 %	33	25 %	12	9 %	54	40 %	23	17 %	7	5 %		

TABLE 3d. Relationship between the morphology of the spermatozoa in the semen of the husband and the result of the S P M test in 135 couples. The physico-chemical properties of the cervical mucus of the wife were favourable for penetration, migration and survival of spermatozoa.

Percentage of morphologically normal head-forms	No. of cases	Result of the S P M test													
		negative		positive											
		number	%	bad	poor	fair	good	excellent	number	%	number	%			
1. <40 %	9	1	12 %	3	33 %	1	11 %	3	33 %	1	11 %				
2. 40-50 %	24	4	17 %	10	42 %	5	21 %	3	12 %	2	8 %				
3. 50-60 %	29			9	31 %	1	3 %	14	49 %	4	14 %	1	3 %		
4. 60-70 %	39	1	3 %	8	20 %	2	5 %	18	46 %	9	23 %	1	3 %		
5. ≥70 %	34			3	9 %	3	9 %	16	47 %	7	20 %	5	15 %		
Total	135	6	4 %	33	25 %	12	9 %	54	40 %	23	17 %	7	5 %		

TABLE 3e. Relationship between the assessment of fertility of the semen of the husband and the result of the S P M test in 135 couples. The physico-chemical properties of the cervical mucus of the wife were favourable for penetration, migration and survival of spermatozoa.

Assessment of the fertility of the semen	No. of cases	Result of the S P M test													
		negative		positive											
		number	%	bad	poor	fair	good	excellent	number	%	number	%			
1. sterile															
2. bad	12	3	25 %	7	59 %	1	8 %	1	8 %						
3. poor	43	2	5 %	21	49 %	7	16 %	10	23 %	3	7 %				
4. passable	29			2	7 %	1	3 %	21	73 %	4	14 %	1	3 %		
5. good	51	1	2 %	3	6 %	3	6 %	22	43 %	16	31 %	6	12 %		
Total	135	6	4 %	33	25 %	12	9 %	54	40 %	23	17 %	7	5 %		

TABLE 4. The results of the SPM test in 50 couples using good semen (≥ 60 million spermatozoa/c.c., $\geq 60\%$ grade 3 motility and $\geq 60\%$ normal head forms) and cervical mucus where one or more physico-chemical properties are considered as unfavourable for penetration, migration and survival of spermatozoa.

No.	Properties of the cervical mucus important for spermatozoal transport					Properties of the semen important for spermatozoal transport				Results of the SPM test										Fertility assessment of the semen	Result of the SPM test			
	Clarity	Viscosity	Spinbarkeit	pH	Glucosetest	Ferment	Sperm density in millions per cc	Motility at commencement of test %	gr	% normal headforms	Penetration density and qualitative motility after two hours:						Qualitative motility of the spermatozoa after:							
											Depth of penetration in cm after:		1 cm		3 cm		5 cm		8 hrs			24 hrs		48 hrs
30 min.	2 hrs.	density	motility	density	motility	density	motility	8 hrs	24 hrs	48 hrs	72 hrs	8 hrs	24 hrs	48 hrs	72 hrs	8 hrs	24 hrs	48 hrs	72 hrs					
1	II	0.8	35	6.3	neg.	+++	128.10 ⁶	60	3+	68	6	6	20- 50	3+	10- 20	3+	10- 20	3+	2+	1+	1+	<1	good	good
2	II	1.2	30	7.2	neg.	neg.	92.10 ⁶	60	3+	80	6	6	100-200	1	100-200	1-	50-100	1-	1	1-	1-	0	good	poor
3	I	1.4	35	6.3	neg.	++	107.10 ⁶	70	3+	78	4 1/2	6	>200	2	20- 50	3+	10- 20	3-	2+	0	0	0	good	fair
4	II	1.7	60	7.5	++	+	180.10 ⁶	80	3+	76	1	2	100-200	<1	0	-	0	-	<1	<1	0	0	good	bad
5	I	2	80	8.3	neg.	++	110.10 ⁶	60	3	80	5	6	>200	1	100-200	1	50-100	3	1	1	0	0	good	good
6	II	2.5	25	8.1	neg.	+++	223.10 ⁶	80	3+	75	1	1 1/2	20- 50	<1	0	-	0	-	1+	1	0	0	good	bad
7	II	2.5	80	6.5	neg.	+++	195.10 ⁶	70	3+	68	6	6	100-200	2	50-100	2+	20- 50	3+	3	1-	0	0	good	good
8	II	2.5	25	8.1	neg.	++	104.10 ⁶	60	4+	66	0	1	sp.	1	0	-	0	-	0	0	0	0	good	bad
9	II	2.8	30	8.1	+++	neg.	128.10 ⁶	60	3+	60	3	5	5- 10	1+	0- 10	1+	0-5	1-	1	1-	0	0	good	poor
10	II	3	50	8.1	+	++	89.10 ⁶	70	3+	68	6	6	100-200	1	100-200	1	50-100	1	1+	<1	<1	0	good	fair
11	I	3.2	50	8.3	trace	++	>200.10 ⁶	80	3+	71	1 1/2	5	20- 50	<1	10- 20	<1	5- 10	<1	<1	0	<1	0	good	poor
12	I	3.2	100	6.9	trace	+++	190.10 ⁶	70	3+	73	4	5	100-200	1	20- 50	2-	5- 10	1+	1	<1	1	<1	good	fair
13	II	3.3	35	7.2	neg.	++	136.10 ⁶	60	3+	62	6	6	50-100	3-	50-100	3-	20- 50	2+	2-	1	1	0	good	good
14	IIIa	3.4	40	8.1	++	neg.	>200.10 ⁶	60	3	65	1	2	20- 50	0	0	-	0	-	0	0	0	0	good	bad
15	I	3.4	40	6.3	neg.	+++	80.10 ⁶	60	3+	66	6	6	>200	2-	20- 50	2+	20- 50	3+	3+	2-	1-	0	good	excellent
16	II	4.2	45	8.1	++	+++	150.10 ⁶	70	3+	77	5	6	>200	2	100-200	2+	20- 50	2+	2	<1	<1	0	good	good
17	IIIa	4.2	40	8.3	neg.	+	170.10 ⁶	60	3+	69	3 1/2	6	>200	<1	10- 20	3	5- 10	0	1	<1	0	0	good	poor
18	I	4.5	45	8.3	+	+++	170.10 ⁶	70	3+	65	3	4	>200	1	20- 50	1	0	-	<1	<1	0	0	good	poor
19	IIIb	4.8	25	8.1	neg.	neg.	129.10 ⁶	70	3+	67	0	0	0	-	0	-	0	-	0	0	0	0	good	neg.
20	II	5.1	25	8.1	+	+++	75.10 ⁶	60	3+	61	2	3	50-100	2+	0-5	2-	0	-	2+	2+	1-	1-	good	bad
21	I	5.2	75	8.3	trace	+++	61.10 ⁶	60	3	60	4	5	100-200	1	10- 20	1	0-5	1	1	1-	0	0	good	fair
22	I	5.5	40	6.9	neg.	+++	65.10 ⁶	60	3+	64	1	3	20- 50	1+	sp.	1	0	-	<1	0	0	0	good	bad
23	II	5.5	25	7.8	neg.	neg.	144.10 ⁶	80	3+	72	0	0	3 1/2	20- 50	2-	0-5	1-	0	-	1	0	0	good	poor
24	IIIa	5.6	30	8.3	++	+	110.10 ⁶	70	3+	79	0	0	0	-	0	-	0	-	0	0	0	0	good	neg.
25	II	5.7	30	8.3	trace	neg.	120.10 ⁶	60	3	61	1	1 1/2	10- 20	<1	0	-	0	-	0	0	0	0	good	bad
26	II	5.8	40	7.8	++	+++	90.10 ⁶	70	3+	72	3	3 1/2	10- 20	<1	0-5	<1	0	-	1-	0	0	0	good	poor
27	I	5.8	50	6	trace	+++	80.10 ⁶	80	3+	64	0	1/2	0	-	0	-	0	-	0	0	0	0	good	bad
28	IIIa	6	45	8.1	+++	+++	94.10 ⁶	60	3+	71	0	3	10- 20	1	0-5	1	0	-	<1	0	0	0	good	bad
29	IIIb	6.3	10	8.1	neg.	neg.	105.10 ⁶	60	3+	60	0	0	0	-	0	-	0	-	0	0	0	0	good	neg.
30	IIIa	6.5	40	8.1	+	neg.	144.10 ⁶	60	3+	68	0	0	0	-	0	-	0	-	0	0	0	0	good	neg.
31	I	7.2	10	8.3	neg.	+++	100.10 ⁶	60	3+	65	0	1	5- 10	1	0	-	0	-	1	0	0	0	good	bad
32	IIIc	7.2	30	8.1	+	+	>200.10 ⁶	60	3+	71	0	0	0	-	0	-	0	-	0	0	0	0	good	neg.
33	II	8.9	25	8.1	++	++	87.10 ⁶	60	3+	65	2 1/2	3 1/2	50-100	<1	10- 20	0	0	-	<1	<1	<1	0	good	poor
34	II	9	30	6	neg.	++	136.10 ⁶	70	4-	63	0	0	0	-	0	-	0	-	0	0	0	0	good	neg.
35	IV	9	25	8.1	++	neg.	201.10 ⁶	60	3+	77	1 1/2	1 1/2	100-200	3-	0	-	0	-	2	0	0	0	good	bad
36	IIIb	9.1	20	8.3	neg.	neg.	115.10 ⁶	60	3+	62	0	1	0- 5	<1	0	-	0	-	0	0	0	0	good	bad
37	IV	9.3	40	7.5	trace	+++	181.10 ⁶	70	3+	63	1	3	100-200	<1	10-20	1	0	-	3	<1	0	0	good	bad
38	IV	9.5	25	8.3	++	+	62.10 ⁶	70	3+	69	0	0	0	-	0	-	0	-	0	0	0	0	good	neg.
39	IIIa	9.6	25	8.1	+	neg.	86.10 ⁶	80	4	69	0	0	0	-	0	-	0	-	0	0	0	0	good	neg.
40	II	10.4	50	8.3	neg.	+	130.10 ⁶	60	3+	65	0	0	0	-	0	-	0	-	0	0	0	0	good	neg.
41	IIIb	12	35	8.3	+	+++	80.10 ⁶	70	3+	72	0	0	0	-	0	-	0	-	0	0	0	0	good	neg.
42	IIIb	12	25	8.1	trace	neg.	88.10 ⁶	70	3+	79	0	0	0	-	0	-	0	-	0	0	0	0	good	neg.
43	I	12.3	15	8.3	neg.	neg.	88.10 ⁶	70	3+	61	0	0	0	-	0	-	0	-	0	0	0	0	good	neg.
44	IIIa	12.5	35	8.1	trace	++	163.10 ⁶	60	3+	60	0	0	0	-	0	-	0	-	0	0	0	0	good	neg.
45	IIIc	12.5	20	8.4	+	neg.	76.10 ⁶	60	3+	63	0	0	0	-	0	-	0	-	0	0	0	0	good	neg.
46	II	15	10	8.3	++	neg.	161.10 ⁶	60	3+	66	0	0	0	-	0	-	0	-	0	0	0	0	good	neg.
47	IIIc	16	20	8.1	neg.	neg.	67.10 ⁶	70	3+	65	0	0	0	-	0	-	0	-	0	0	0	0	good	neg.
48	IIIc	16	15	6.6	neg.	neg.	104.10 ⁶	80	3+	75	0	0	0	-	0	-	0	-	0	0	0	0	good	neg.
49	IIIb	18	15	6	+	neg.	203.10 ⁶	80	4+	75	0	0	0	-	0	-	0	-	0	0	0	0	good	neg.
50	I	18	10	7.5	+	+++	149.10 ⁶	60	3+	80	0	0	0	-	0	-	0	-	0	0	0	0	good	neg.

TABLE 5. The velocity of spermatozoa in cervical mucus at RT determined with the aid of the S P M test
Total 54 couples.

No.	Properties of the cervical mucus important for spermatozoal transport						Properties of the semen important for spermatozoal transport				Assessment of fertility of the semen in the cervical mucus in mm/min.	Speed of the spermatozoa in the cervical mucus in mm/min.
	Clarity	Viscosity	Spinbarkeit	pH	Glucosetest	Ferment	Sperm. density in millions/cc	Motility at commencement of the test		% normal headforms		
							%	gr				
1	I	1.1	70	8.1	neg.	+++	20.10 ⁶	60	3—	52	passable	1.2
2	I	1.1	45	8.1	neg.	+++	23.10 ⁶	40	3+	62	passable	1.9
3	I	1.4	40	7.2	neg.	+++	25.10 ⁶	40	3+	62	passable	1.2
4	I	0.8	80	7.8	neg.	+++	25.10 ⁶	70	3+	72	good	1.1
5	I	1.4	30	8.1	neg.	+++	25.10 ⁶	60	3+	56	passable	2.1
6	I	1.1	40	7.5	neg.	+++	28.10 ⁶	70	3+	60	good	1.6
7	I	1.4	30	8.1	neg.	+++	31.10 ⁶	60	3+	59	passable	2.1
8	I	2.8	80	7.8	neg.	+++	33.10 ⁶	40	3+	46	passable	1.7
9	I	1.7	30	8.1	++	+++	34.10 ⁶	40	3+	44	poor	1.9
10	II	1.4	55	7.8	neg.	+++	35.10 ⁶	70	3+	56	passable	1.5
11	I	2	35	7.8	tr.	+++	35.10 ⁶	70	3+	62	good	2.3
12	I	1.4	35	7.2	neg.	+++	39.10 ⁶	50	3+	64	passable	2.1
13	I	2	35	7.2	neg.	+++	39.10 ⁶	40	3+	50	passable	1.3
14	I	1.7	30	7.5	neg.	+++	40.10 ⁶	60	3+	58	passable	1.7
15	II	2.5	45	8.1	neg.	+++	48.10 ⁶	70	3+	62	good	1.4
16	II	1.1	65	7.5	neg.	+++	50.10 ⁶	70	3+	62	good	1.6
17	I	2.4	30	8.1	neg.	+++	51.10 ⁶	60	3+	57	passable	1.4
18	II	1.5	40	8.1	neg.	+++	51.10 ⁶	40	3+	63	passable	1.7
19	I	2.4	30	7.2	neg.	+++	51.10 ⁶	70	3+	63	good	1.7
20	I	1.9	40	8.1	neg.	+++	54.10 ⁶	40	3+	70	good	2.8
21	II	1.4	35	8.1	tr.	+++	55.10 ⁶	40	3+	55	passable	1.4
22	I	1.6	35	8.1	neg.	+++	58.10 ⁶	50	3+	69	passable	2.1
23	II	1.7	30	7.5	neg.	+++	58.10 ⁶	40	4+	69	good	2.1
24	II	1.6	30	7.5	neg.	+++	66.10 ⁶	60	3+	74	good	2.2
25	II	1	65	8.1	neg.	+++	67.10 ⁶	50	3+	64	good	1.3
26	II	1.7	40	7.2	+	+++	75.10 ⁶	40	2+	68	passable	2
27	I	1.7	40	8.1	+	+++	75.10 ⁶	50	3+	55	passable	1.7
28	I	2	85	8.1	neg.	+++	77.10 ⁶	80	4+	77	good	1.2
29	II	1.6	30	8.1	+	+++	80.10 ⁶	80	3+	74	good	2.1
30	I	1	35	7.5	neg.	+++	85.10 ⁶	80	3+	78	good	2.2
31	II	3.2	30	7.6	neg.	+++	86.10 ⁶	40	3+	61	good	1.2
32	II	2	30	7.2	neg.	+++	89.10 ⁶	70	3+	74	good	2.3
33	I	0.8	30	7.5	neg.	+++	110.10 ⁶	60	3+	73	good	2.4
34	I	1.6	30	7.8	neg.	+++	114.10 ⁶	80	3+	71	good	1.6
35	II	2	35	8.1	++	+++	115.10 ⁶	40	3+	75	good	1.8
36	II	1.5	75	7.2	neg.	+++	131.10 ⁶	70	3+	76	good	1.4
37	I	2.4	35	8.1	+	+++	134.10 ⁶	60	3	71	good	1.8
38	II	1.1	45	7.2	neg.	+++	140.10 ⁶	70	3+	76	good	2.1
39	I	1	55	7.2	neg.	+++	144.10 ⁶	80	4+	72	good	2.4
40	I	2	35	7.8	neg.	+++	147.10 ⁶	60	3+	81	good	1.3
41	II	1.5	40	7.2	+	+++	160.10 ⁶	60	3+	65	good	2.2
42	II	1	35	7.5	tr.	+++	169.10 ⁶	40	3+	69	good	2.5
43	II	1.5	45	8.1	+	+++	180.10 ⁶	40	3+	77	good	2
44	I	0.8	40	7.5	neg.	+++	185.10 ⁶	40	3+	52	passable	1.8
45	I	2.2	35	8.1	++	+++	187.10 ⁶	60	3+	75	good	2.1
46	I	1.7	75	8.1	++	+++	193.10 ⁶	70	3+	76	good	2.3
47	I	0.8	40	7.5	neg.	+++	197.10 ⁶	80	4+	86	good	1.7
48	I	2.4	30	8.1	++	+++	201.10 ⁶	80	4—	72	good	1
49	I	1	55	7.2	neg.	+++	215.10 ⁶	40	3+	65	good	2.5
50	II	2.5	25	8.1	neg.	+++	223.10 ⁶	80	3+	75	good	2.1
51	I	2.1	35	8.1	+	+++	270.10 ⁶	40	4—	74	good	2
52	I	1.6	50	7.8	+	+++	304.10 ⁶	40	3+	59	passable	2
53	II	1.4	45	7.2	neg.	+++	355.10 ⁶	40	4—	73	good	1.8
54	II	2	35	7.2	neg.	+++	478.10 ⁶	70	4+	65	good	2.1

average speed: 1.8 mm/min. range: 1-2.8 mm/min.

TABLE 6. Investigation into the influence of the vaginal environment on spermatozoal motility and on the capacity of the spermatozoa to penetrate into normal cervical mucus obtained during the ovulation period. A total of 14 investigations of 10 couples.

No.	Spermatozoal Motility of density in the spermatozoa, 10-15 min. after ejaculation			Acidity and qualitative motility in the seminal pool at different times after the intra-vaginal semen application														Result of the SPM test with spermatozoa which were taken from the seminal pool at different times after intravaginal semen application			
				After 5 min.		After 10 min.		After 15 min.		After 20 min.		After 35 min.		After 60 min.		After 120 min.		Removal after 10 min.	Removal after 20 min.	Removal after 35 min.	Removal after 60 min.
				pH	gr	pH	gr	pH	gr	pH	gr	pH	gr	pH	gr	pH	gr				
		%	gr	Motility		Motility		Motility		Motility		Motility		Motility							
1	79.10 ⁶	80	4	8.1	3	8.1	2	8.1	2	7.8	1	7.2	1+	7	<1	6	0	fair	fair	poor	neg.
2a	50.10 ⁶	70	4	7	3	6.9	2	6.6	2	6.6	2	6.7	1	6	<1	5.4	0	fair	.	poor	neg.
2b	80.10 ⁶	80	5—	7.4	4—	7.6	3	7.2	2+	6.6	2	6	2—	5.4	1	5.2	0	good	fair	poor	neg.
2c	84.10 ⁶	90	4	6.3	3—	5.2	<1	4.5	0	4.5	0	4.2	0	4	0	3.8	0	neg.	neg.	neg.	.
3a	77.10 ⁶	80	4+	8.1	4—	7.8	4—	7.8	4—	7.2	4—	6.7	2—	5.4	0	5.2	0	excellent	good	poor	neg.
3b	88.10 ⁶	80	4+	8.1	4	8.1	4	6.3	2+	8.1	4	6.3	2	5.8	1	5.2	<1	fair	fair	poor	bad
4	180.10 ⁶	80	4+	7.8	4	7.8	4	7.8	4	7.8	4—	6.5	1+	6.5	0	5.8	0	.	good	poor	neg.
5	190.10 ⁶	80	4	8.1	4—	7.8	3+	7.8	4—	7.5	3	7.2	2	6.6	2	6.4	1	excellent	good	poor	neg.
6a	120.10 ⁶	80	5—	8.1	4+	8.1	4+	8.1	4+	8.1	4+	7.2	3	7	3	7	3—	excellent	excellent	good	fair
6b	110.10 ⁶	80	5—	8.1	4+	8.1	4	7.8	4	7.4	4	7.2	3	6.9	3—	6.9	2+	excellent	good	good	fair
7	150.10 ⁶	80	4+	7.8	4—	7.4	3	6.9	2+	6.6	2+	5.4	1+	4.8	0	4.5	0	excellent	good	bad	bad
8	180.10 ⁶	80	4+	8.1	4+	7.8	4+	7.5	4+	7.2	3	6.9	3—	5.7	1	5.4	<1	good	fair	fair	bad
9	76.10 ⁶	30	2+	7.8	2+	7.4	2+	7.2	2	7.2	2+	6.9	2—	5.4	0	5.2	0	bad	neg.	neg.	.
10	32.10 ⁶	60	4—	7.8	3+	7.2	3+	7.2	3+	6.9	2—	7.5	2+	6.9	2+	6.9	2	.	poor	.	.

TABLE 7. Results of the SPM test in 15 couples where the wife took 0.5 mg *norethindron acetate* per day.

No.	Number of days tablets used	Properties of the semen which affect the penetration capacity of the spermatozoa			Properties of the cervical mucus important for spermatozoal transport					Results of the SPM test performed with cervical mucus obtained during the ovulation period												
		Spermatozoal density in millions/cc	Motility of the spermatozoa at commencement of the test %		Clarity	Viscosity	Spinnbarkeit	pH	Glucosetest	Ferntest	Homologous test					Control test with normal cervical mucus						
											Depth of penetration in cm after:		Penetration density at 5 cm after 2 hrs	Motility grade at 5 cm after 2 hrs	Duration of motility at least	Classification of the results	Depth of penetration in cm after:		Penetration density at 5 cm after 2 hrs	Motility grade at 5 cm after 2 hrs	Duration of motility at least	Classification of the results
30 min.	2 hrs.	30 min.	2 hrs.																			
1	12	170.10 ⁶	50	2+	IIIb	neg.	0	0	0	.	.	neg.	4	6	5-10	2—	24 hrs	fair
2	13	>200.10 ⁶	80	4	IIIb	>20	.	8.1	+++	++	0	0	0	.	.	neg.	6	6	20-50	3+	72 hrs	excellent
3	14	200.10 ⁶	70	3+	IIIc	.	.	8.1	++	neg.	0	0	0	.	.	neg.	6	6	50-100	3+	72 hrs	excellent
4	14	89.10 ⁶	70	3+	II	3	50	8.1	+	++	6	6	50-100	1	48 hrs.	fair	6	6	50-100	3	72 hrs	excellent
5	15	46.10 ⁶	40	3+	IIIc	>20	.	8.1	trace	++	0	0	0	.	.	neg.	6	6	10-20	3—	48 hrs	good
6	15	54.10 ⁶	40	3+	IV	>20	45	8.3	+++	neg.	0	0	0	.	.	neg.	5	6	5-10	2—	48 hrs	fair
7	26	190.10 ⁶	40	3+	IIIa	0	0	0	.	.	neg.	6	6	50-100	3+	72 hrs	excellent
8	27	60.10 ⁶	40	3+	I	>20	30	8.1	trace	+	0	0	0	.	.	neg.	5	6	5-10	2—	24 hrs	fair
9	27	190.10 ⁶	80	4—	IIIb	.	.	8.1	.	.	0	0	0	.	.	neg.	6	6	50-100	3+	72 hrs	excellent
10	28	148.10 ⁶	40	2	IIIb	.	.	8.3	+++	neg.	0	0	0	.	.	neg.	6	6	100-200	4	48 hrs	excellent
11	31	45.10 ⁶	40	3+	IIIb	.	.	7.5	trace	neg.	0	0	0	.	.	neg.	5	6	5-10	1	8 hrs	fair
12	47	35.10 ⁶	40	3—	IIIa	9.8	.	.	.	neg.	0	0	0	.	.	neg.	2	5	0-5	2+	24 hrs	fair
13	59	163.10 ⁶	60	3+	IIIa	12.5	35	8.1	neg.	++	0	0	0	.	.	neg.	6	6	10-20	2	24 hrs	good
14	76	90.10 ⁶	60	3+	IIIb	>20	.	8.1	+++	+	0	0	0	.	.	neg.	5	6	20-50	2+	48 hrs	good
15	98	150.10 ⁶	50	3+	IIIa	14.4	.	8.3	neg.	neg.	0	0	0	.	.	neg.	6	6	10-20	2	24 hrs	good

TABLE 8. Results of the SPM test in 13 couples where the wife took 0.5 mg *megestrol acetate* daily.

No.	Number of days tablets used	Properties of the semen which affect the penetration capacity of the spermatozoa			Properties of the cervical mucus important for spermatozoal transport					Results of the SPM test performed with cervical mucus obtained during the ovulation period												
		Spermatozoal density in millions/cc	Motility of the spermatozoa at commencement of the test %		Clarity	Viscosity	Spinnbarkeit	pH	Glucosetest	Ferntest	Homologous test					Control test with normal cervical mucus						
											Depth of penetration in cm after:		Penetration density at 5 cm after 2 hrs	Motility grade at 5 cm after 2 hrs	Duration of motility at least	Classification of the results	Depth of penetration in cm after:		Penetration density at 5 cm after 2 hrs	Motility grade at 5 cm after 2 hrs	Duration of motility at least	Classification of the results
30 min.	2 hrs.	30 min.	2 hrs.																			
1	18	>200.10 ⁶	<5	2+	IIIb	.	.	7.5	.	.	0	0	0	.	.	neg.	2	3	0	.	24 hrs	bad
2	19	92.10 ⁶	50	3	IIIb	>20	.	8.1	++	+	0	0	0	.	.	neg.	6	6	50-100	3	72 hrs	excellent
3	25	88.10 ⁶	70	3+	IIIb	12.3	15	8.3	neg.	neg.	0	0	0	.	.	neg.	6	6	10-20	2	48 hrs	good
4	26	72.10 ⁶	20	3—	IIIc	20	.	8.3	+	neg.	0	0	0	.	.	neg.	3 1/2	6	0-5	1	24 hrs	fair
5	27	26.10 ⁶	60	3+	IIIb	6	70	8.3	+	+	1 1/2	3	0	.	.	bad	6	6	10-20	2	24 hrs	good
6	28	122.10 ⁶	70	3+	IIIb	>20	.	8.3	.	neg.	0	0	0	.	.	neg.	6	6	50-100	3	48 hrs	excellent
7	28	35.10 ⁶	60	3+	IIIc	.	.	7.2	+++	neg.	0	0	0	.	.	neg.	6	6	20-50	3+	48 hrs	excellent
8	28	52.10 ⁶	30	3+	II	7.5	50	8.3	+++	+	0	0	0	.	.	neg.	6	6	20-50	3	48 hrs	excellent
9	30	94.10 ⁶	60	3+	IIIa	6	45	8.1	+++	+++	0	0	0	.	.	neg.	1	5 1/2	20-50	3	24 hrs	fair
10	30	>200.10 ⁶	60	3+	IIIc	7.2	30	8.1	++	+	0	0	0	.	.	neg.	5	6	20-50	2+	48 hrs	good
11	36	143.10 ⁶	50	3+	IIIb	.	.	8.3	+	+	0	0	0	.	.	neg.	6	6	20-50	3	72 hrs	excellent
12	40	190.10 ⁶	80	3+	IIIc	.	.	8.3	+	neg.	0	0	0	.	.	neg.	6	6	20-50	3	72 hrs	excellent
13	60	20.10 ⁶	70	3+	IIIa	>20	.	8.1	+	+	0	0	0	.	.	neg.	1	5 1/2	20-50	3+	24 hrs	fair

TABLE 9. Results of the SPM test in 20 couples where the wife took 0.5 mg *lynestrenol* daily.

No.	Number of days tablets used	Properties of the semen which affect the penetration capacity of the spermatozoa			Properties of the cervical mucus important for spermatozoal transport						Results of the SPM test performed with cervical mucus obtained during the ovulation period											
		Spermatozoal density in millions/cc	Motility of the spermatozoa at commencement of the test %	gr	Clarity	Viscosity	Spinnbarkeit	pH	Glucosetest	Ferntest	Homologous test					Classification of the results	Control test with normal cervical mucus					
											Depth of penetration in cm after:		Penetration density at 5 cm after 2 hrs	Motility grade at 5 cm after 2 hrs	Duration of motility at least		Depth of penetration in cm after:		Penetration density at 5 cm after 2 hrs	Motility grade at 5 cm after 2 hrs	Duration of motility at least	Classification of the results
30 min.	2 hrs.	30 min.	2 hrs.	30 min.	2 hrs.																	
1	9	88.10 ⁶	60	3+	I	8.9	25	8.1	++	++	2 1/2	3 1/2	0	-	24 hrs	poor	5 1/2	6	10-20	2	24 hrs	good
2	13	87.10 ⁶	60	3+	IIIa	16.4	.	7.2	++	neg.	0	0	0	-	-	neg.	6	6	10-20	2+	48 hrs	good
3	20	110.10 ⁶	60	3+	IIIa	18.2	15	7.2	+++	neg.	0	0	0	-	-	neg.	6	6	10-20	2+	24 hrs	good
4	25	200.10 ⁶	60	3+	IIIa	3.4	.	8.1	++	neg.	1	2	0	-	8 hrs	bad	5	6	10-20	2	24 hrs	good
5	26	105.10 ⁶	60	3+	IIIc	6.3	10	8.1	neg.	neg.	0	0	0	-	-	neg.	1 1/2	3 1/2	0	-	24 hrs	poor
6	26	141.10 ⁶	10	3+	II	.	.	8.3	trace	++	0	0	0	-	-	neg.	1/2	2	0	-	24 hrs	bad
7	26	152.10 ⁶	30	3+	IIIa	5.2	40	8.1	trace	++	1	3	0	-	8 hrs	bad	4 1/2	6	10-20	2	24 hrs	good
8	27	149.10 ⁶	60	3+	I	18	10	7.5	+	++	0	0	0	-	-	neg.	6	6	20-50	2	24 hrs	good
9	28	160.10 ⁶	30	1+	IIIa	.	10	8.3	trace	neg.	0	0	0	-	-	neg.	6	6	5-10	1-	8 hrs	poor
10	28	189.10 ⁶	70	3+	II	.	.	7.5	neg.	neg.	0	0	0	-	-	neg.	5 1/2	6	20-50	2+	24 hrs	good
11	30	>200.10 ⁶	80	3+	I	3.2	50	8.3	trace	++	1 1/2	5	5-10	<1	8 hrs	poor	6	6	20-50	3	48 hrs	excellent
12	30	27.10 ⁶	30	2	IIIa	.	.	7.5	trace	neg.	0	0	0	-	-	neg.	3	5	0-5	1	8 hrs	fair
13	32	115.10 ⁶	60	3+	IIIb	9.1	20	8.3	neg.	neg.	0	1	0	-	2 hrs	bad	6	6	0-5	2	24 hrs	fair
14	33	180.10 ⁶	60	3+	IIIa	15	10	.	trace	neg.	0	0	0	-	-	neg.	5	6	10-20	2	24 hrs	good
15	34	190.10 ⁶	30	3-	IIIa	.	.	7.5	trace	neg.	0	0	0	-	-	neg.	5	6	100-200	2+	48 hrs	good
16	34	32.10 ⁶	40	2+	IIIa	.	.	7.8	+	neg.	0	0	0	-	-	neg.	3 1/2	6	0-5	2	8 hrs	fair
17	35	170.10 ⁶	60	3+	IIIa	4.2	40	8.3	neg.	+	1 1/2	3 1/2	0	-	24 hrs	poor	2 1/2	5	0-5	1+	24 hrs	fair
18	56	153.10 ⁶	40	3+	IIIa	.	.	8.1	trace	neg.	0	0	0	-	-	neg.	6	6	10-20	2+	24 hrs	good
19	60	36.10 ⁶	40	3+	IIIa	16	5	7.8	trace	neg.	0	0	0	-	-	neg.	3 1/2	5	0-5	1	24 hrs	fair
20	60	170.10 ⁶	60	3+	IIIa	4.2	40	8.3	neg.	+	.	3 1/2	0	-	-	poor	6	6	10-20	2+	24 hrs	good

TABLE 10. Results of the SPM test in 8 couples where the wife took 0.5 mg Δ 5-10 *lynestrenol* daily.

No.	Number of days tablets used	Properties of the semen which affect the penetration capacity of the spermatozoa			Properties of the cervical mucus important for spermatozoal transport						Results of the SPM test performed with cervical mucus obtained during the ovulation period											
		Spermatozoal density in millions/cc	Motility of the spermatozoa at commencement of the test %	gr	Clarity	Viscosity	Spinnbarkeit	pH	Glucosetest	Ferntest	Homologous test					Classification of the results	Control test with normal cervical mucus					
											Depth of penetration in cm after:		Penetration density at 5 cm after 2 hrs	Motility grade at 5 cm after 2 hrs	Duration of motility at least		Depth of penetration in cm after:		Penetration density at 5 cm after 2 hrs	Motility grade at 5 cm after 2 hrs	Duration of motility at least	Classification of the results
30 min.	2 hrs.	30 min.	2 hrs.	30 min.	2 hrs.																	
1	23	50.10 ⁶	10	1	IIIb	6.5	25	8.3	++	neg.	0	0	0	-	-	neg.	4	5	0-5	2	8 hrs	fair
2	25	130.10 ⁶	50	3+	I	1.7	65	7.5	neg.	+++	5	6	50-100	3+	24 hrs	good	6	6	10-20	3-	24 hrs	good
3	28	130.10 ⁶	60	3+	II	10.4	50	8.3	neg.	+	0	0	0	-	-	neg.	6	6	50-100	2+	24 hrs	good
4	28	200.10 ⁶	60	3+	IIIc	7.2	30	8.1	+	+	0	0	0	-	-	neg.	5	6	10-20	2	24 hrs	good
5	28	110.10 ⁶	60	3	I	2	80	8.3	neg.	++	6	6	50-100	3	24 hrs	good	6	6	20-50	2	24 hrs	good
6	31	200.10 ⁶	50	3	I	1.4	150	8.3	sp	+++	4	6	50-100	3+	24 hrs	good	4	5	0-5	2	8 hrs	fair
7	34	89.10 ⁶	50	3+	I	1.7	90	7.8	sp	++	4	6	>200	2	24 hrs	good	4 1/2	6	50-100	2-	24 hrs	fair
8	48	43.10 ⁶	60	3+	I	1.4	50	8.1	neg.	+++	2	5	0-5	4	24 hrs	fair	1 1/2	5	0-5	2+	8 hrs	fair

TABLE 11. Relationship between the semen properties, the spermatozoal agglutination test and the spermatozoal immobilization test in 12 men showing agglutination in the ejaculate.

No.	Spermatozoal density in millions/cc	Nature of the spermatozoal agglutination in the ejaculate	Semen properties				Spermatozoal agglutinin titre (Dr. Ph. Rümke)		Result of the spermatozoal immobilization test (own laboratory)
			Spermatozoal motility		bloodserum	semen			
			On receipt	after 24 hrs R.T.					
quant.	qual.	quant.	qual.						
1	66	tail agglutination	10 %	1+	0 %	0	1 : 64	.	weakly positive
2	19	" "	20 %	3+	<5 %	1+	1 : 128	.	pos.
3	50	" "	10 %	1+	5 %	1+	1 : 1024	.	pos.
4	14	" "	<5 %	1+	<5 %	1+	1 : 1024	.	pos.
5	100	" "	70 %	3+	40 %	3—	1 : 32	.	neg.
6	110	" "	20 %	3—	<5 %	1+	1 : 512	1 : 32	pos.
7	138	" "	30 %	3+	20 %	3—	1 : 64	1 : 32	pos.
8	34	" "	40 %	2+	20 %	2+	1 : 256	1 : 8	pos.
9	40	" "	20 %	<1	<5 %	<1	1 : 256	1 : 256	pos.
10	17	" "	10 %	<1	0 %	0	1 : 1024	1 : 16	pos.
11	128	" "	20 %	2+	<5 %	<1	1 : 512	1 : 256	pos.
12	9	" "	10 %	1+	<5 %	<1	1 : 1024	.	weakly positive

TABLE 12. Relationship between the spermatozoal agglutination test and the spermatozoal immobilization test in 9 men with obstructive azoospermia.

No.	Volume of ejaculate	pH of the ejaculate	Fructose content of the ejaculate	Reason for obstructive azoospermia	Spermatozoal agglutinin titre (Dr. Ph. Rümke)		Result of the spermatozoal immobilization test (own laboratory)
					bloodserum	semen	
1	1.5 cc	6.4	11 mg %	Bilateral regression of the wolffian duct	1 : 512	.	pos.
2	1.5 cc	6.5	8 mg %	"	1 : 32	neg.	neg.
3	1 cc	6.3	14 mg %	"	1 : 16	neg.	neg.
4	1 cc	6.5	12 mg %	"	1 : 8	neg.	neg.
5	1.5 cc	6.6	10 mg %	"	1 : 8	neg.	neg.
6	4.5 cc	8.1	245 mg %	bilateral obstruction in epididymis	1 : 1024	1 : 256	neg.
7	3.5 cc	8	285 mg %	not clear	1 : 512	.	weakly pos.
8	4.5 cc	8.1	247 mg %	bilateral obstruction in epididymis	1 : 128	neg.	neg.
9	5 cc	8	160 mg %	not clear	1 : 8	neg.	neg.

TABLE 13. Relationship between semen properties, spermatozoal agglutination test and spermatozoal immobilization test in 10 men with asthenozoospermia.

No.	Spermatozoal density in millions/cc	Semen properties				Spermatozoal agglutinin titre (Dr. Ph. Rümke)		Result of the spermatozoal immobilization test (own laboratory)
		Spermatozoal motility		after 24 hrs R.T.	Blood serum	Semen		
		on receipt	quant.				qual.	
quant.	qual.	quant.	qual.					
1	58	30 %	2+	5 %	1	1 : 256	.	neg.
2	40	<5 %	<1	0 %	0	1 : 512	.	pos.
3	1	<5 %	1+	0 %	0	1 : 512	.	neg.
4	69	20 %	3—	5 %	2—	1 : 4	.	neg.
5	3	5-10 %	1+	<5 %	<1	1 : 128	.	neg.
6	6	30 %	2+	<5 %	1+	1 : 8	neg.	neg.
7	82	<5 %	<1	0 %	0	1 : 1024	1 : 32	pos.
8	24	<5 %	<1	0 %	0	neg.	.	pos.
9	4	5-10 %	2+	<5 %	<1	1 : 256	1 : 32	neg.
10	7	<5 %	<1	0 %	0	1 : 512	1 : 4	pos.

TABLE 14. Relationship between the morphology of the spermatozoa in the semen and of the spermatozoa which have penetrated from this semen into cervical mucus (at least 3 cm.) in the S P M test.

No.	Percentage of spermatozoa with abnormal headforms in the semen	Percentage of spermatozoa with abnormal headforms in the cervical mucus inside the second half of the capillary tube	Decrease of abnormal headforms after arrival of the spermatozoa in the second half of the capillary tube (expressed as per cent of the percentage of abnormal headforms in the semen)
1	29	16	45
2	24	12	50
3	36	14	61
4	41	12	70
5	36	21	42
6	45	27	40
7	26	12	54
8	23	15	35
9	50	36	28
10	26	13	50
11	24	15	38
12	26	20	23
13	32	17	47
14	47	31	34
15	32	4	88
16	21	11	48
17	26	14	46
18	30	17	43
19	25	22	12
20	21	13	38
21	37	29	22
22	30	14	53
23	35	15	57

Average decrease: 45 % range: 12-88 %

TABLE 15. Relationship between the results of the Miller-Kurzrok test and the SPM test in 52 cases where both tests were performed simultaneously.

No.	Results of the Miller-Kurzrok test		Results of the SPM test						Properties of the cervical mucus important for spermatozoal transport					
	Degree of phalanx formation**	Intensity of spermatozoal penetration*	Depth of penetration in cm. after 30 min.	Depth of penetration in cm. after 2 hrs.	Density of penetration after 2 hrs. at 5 cm.	Qual. motility after 2 hrs. at 5 cm.	Duration of motility at least:	Classification of the test	Clarity	Viscosity	Spinnbarkeit	pH	Glucosetest	Ferntest
1	+++	spor.	0	0	0	-	-	neg.	IIIa	5.8	30	7.2	.	neg.
2	+++	spor.	0	0	0	-	-	neg.	IIIa	6.2	40	8.3	tr.	+
3	+++	neg.	0	0	0	-	-	neg.	I	7.7	30	8.3	++	+++
4	+++	spor.	0	1/2	0	-	-	bad	I	5.8	50	6	tr.	+++
5	+++	spor.	0	1 1/2	0	-	8 hrs.	bad	II	7	20	7.8	+	++
6	+++	spor.	0	1/2	0	-	8 hrs.	bad	II	4	30	7.5	neg.	++
7	+++	neg.	0	0	0	-	-	neg.	I	12.3	5	7.5	tr.	+
8	+++	+++	1	3	0	-	24 hrs.	bad	IV	9.3	40	7.5	tr.	+++
9	+++	spor.	0	0	0	-	-	neg.	I	10.4	50	8.3	neg.	+
10	+++	spor.	0	1	0	-	8 hrs.	bad	I	7.2	10	8.3	neg.	+++
11	+++	spor.	0	0	0	-	-	neg.	I	7.5	40	8.3	neg.	+++
12	+++	+++	0	0	0	-	-	neg.	III	12.5	35	8.1	tr.	++
13	+++	spor.	0	0	0	-	-	neg.	IIIc	7.2	30	8.1	+	+
14	+++	spor.	2	3	0	-	2 hrs.	bad	IIIa	7.8	30	8.7	tr.	+
15	++	spor.	0	0	0	-	-	neg.	IV	4.2	.	6.7	neg.	+
16	++	+	1 1/2	5	sp.	1	72 hrs.	fair	II	3	35	8.1	tr.	+++
17	++	neg.	4	6	0-5	2-	72 hrs.	fair	I	5	45	7.2	neg.	+++
18	++	spor.	1 1/2	2	0	-	24 hrs.	bad	I	3.8	40	8.3	neg.	+++
19	++	+	3	5	0-5	4	4 hrs.	fair	I	4.7	40	7.2	neg.	+++
20	++	spor.	2	3	0	-	72 hrs.	bad	I	5.1	25	8.1	+	+++
21	++	+	3	3 1/2	.	.	24 hrs.	poor	I	3.5	40	7.8	tr.	+++
22	++	+++	6	6	20-50	3	72 hrs.	excellent	I	2.3	50	8.1	neg.	+++
23	++	+++	6	6	50-100	3	72 hrs.	excellent	I	3.3	75	8.1	+	+
24	+	++	4	5	5-10	1	72 hrs.	fair	I	3.2	100	6.9	tr.	+++
25	+	+++	6	6	100-200	1+	48 hrs.	fair	I	2	90	8.1	+	+++
26	+	+++	1 1/2	3	0	-	24 hrs.	bad	I	3	50	8.1	++	+++
27	+	+++	6	6	50-100	3+	48 hrs.	excellent	I	1.4	30	8.1	neg.	+++
28	+	spor.	6	6	20-50	2+	48 hrs.	good	I	3.3	35	7.2	neg.	++
29	+	+	6	6	0-5	1	8 hrs.	poor	I	3.5	90	8.1	+	++
30	+	++	4 1/2	5	0-5	1	72 hrs.	fair	I	1.7	90	7.8	tr.	+++
31	+	spor.	2 1/2	2 1/2	0	-	8 hrs.	bad	IIIa	3.3	40	8.3	tr.	+
32	+	+	6	6	20-50	2-	48 hrs.	fair	I	2.8	60	7.8	+	+++
33	spor.	+	6	6	0-5	2	8 hrs.	fair	I	1.7	80	8.3	tr.	+++
34	spor.	+++	5	6	50-100	3	24 hrs.	good	II	2	80	8.3	neg.	++
35	spor.	+++	6	6	10-20	1	72 hrs.	fair	I	2.8	65	6.6	neg.	+++
36	spor.	++	4	5	50-100	2+	8 hrs.	fair	I	1.4	100	7.5	neg.	++
37	spor.	++	6	6	20-50	2+	8 hrs.	fair	II	2.4	30	8.1	neg.	+++
38	spor.	spor.	6	6	20-50	2+	8 hrs.	fair	I	1	30	7.8	neg.	+++
39	spor.	+++	6	6	10-20	1+	24 hrs.	fair	I	1.4	60	8.3	tr.	+++
40	spor.	spor.	2	6	5-10	2+	48 hrs.	fair	II	1.4	25	6	neg.	+++
41	spor.	+++	3 1/2	3 1/2	0	-	8 hrs.	poor	I	1.4	70	8.3	tr.	+++
42	spor.	spor.	0	0	0	-	-	neg.	IV	>20	.	8.3	+++	neg.
43	spor.	neg.	0	0	0	-	-	neg.	I	>20	.	8.1	tr.	+
44	spor.	spor.	0	0	0	-	-	neg.	IIIb	>20	.	8.1	+++	+
45	neg.	+++	6	6	50-100	4	24 hrs.	good	I	1.2	80	6.3	neg.	+++
46	neg.	+++	5	6	20-50	2	24 hrs.	good	I	1.4	70	6.9	tr.	+++
47	neg.	+++	4	5	50-100	3+	24 hrs.	fair	I	1.4	150	8.3	tr.	+++
48	neg.	++	6	6	5-10	1+	24 hrs.	fair	I	1.4	70	7.5	neg.	+++
49	neg.	+	6	6	20-50	2	24 hrs.	good	II	1	30	8.1	neg.	+++
50	neg.	+++	5	6	50-100	3+	24 hrs.	good	I	1.7	65	7.5	neg.	+++
51	neg.	+++	4	6	50-100	3+	24 hrs.	fair	I	1.4	150	8.3	tr.	+++
52	neg.	spor.	1	1	0	-	8 hrs.	bad	I	1	100	7.5	++	+++

** +++ = pronounced phalanx formation
 ++ = moderate " "
 + = restricted " "
 spor. = very slight " "
 neg. = no " "

* +++ = very good penetration of spermatozoa into cervical mucus
 ++ = reasonably good penetration
 + = moderate to limited penetration
 spor. = very limited penetration
 neg. = no penetration

TABLE 16. Relationship between the fertility assessment of the husband's semen and the result of the Sims-Huhner test in 160 couples. The physico-chemical properties of the wife's cervical mucus were favourable for penetration, migration and survival of spermatozoa.

Fertility assessment of the semen	No. of cases	Result of the Sims-Huhner test											
		negative		positive									
		number	%	bad		poor		fair		good		excellent	
number	%			number	%	number	%	number	%	number	%		
1. Sterile	13	13	100 %										
2. Bad	7	6	86 %			1	14 %						
3. Poor	42	17	40 %	4	10 %	6	14 %	12	29 %	2	5 %	1	2 %
4. Passable	41	6	15 %	7	17 %	7	17 %	14	34 %	6	15 %	1	2 %
5. Good	57	5	9 %	7	12 %	10	18 %	13	22 %	16	29 %	6	10 %
Total	160	47	29 %	18	11 %	24	15 %	39	25 %	24	15 %	8	5 %